

# 1. MAIN

## Exploded View

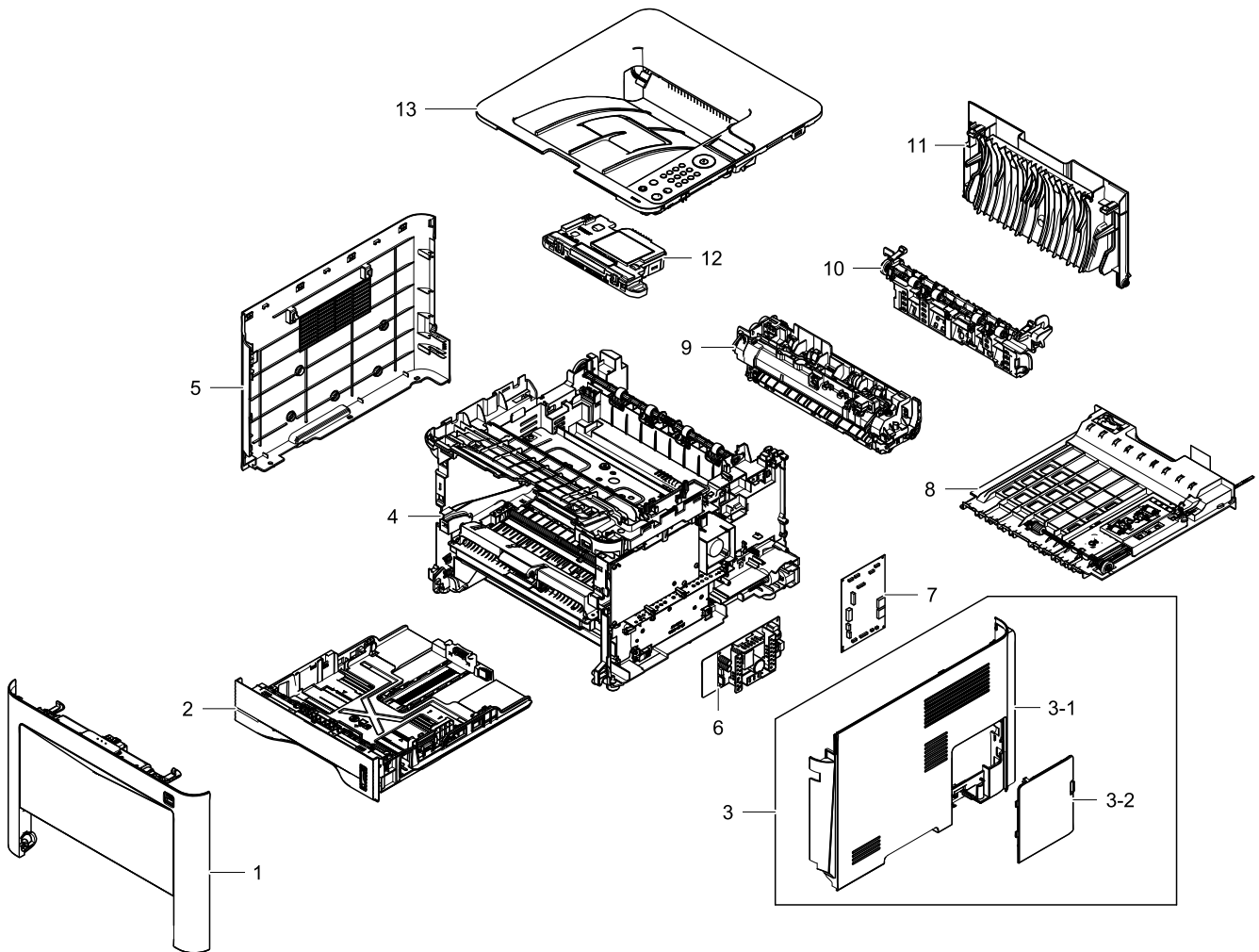

## Parts List

No.	Lvl.	Loc.	Material Code	Description & Specification	SNA	Qty.
1	1		JC95-01840C	COVER-FRONT; SL-M3820ND,SEC,SPLIT GRAY	SA	1
2	1		JC90-01143B	CASSETTE; ML-4210ND,SEC	SA	1
3	2		JC95-01838G	COVER-RIGHT; SL-M3320ND,SEC,SPLIT GRAY	SA	1
3-1	3		JC63-04140A	COVER-RIGHT; SL-M4020ND,ABS+PC,2.5,354.3,	SNA	1
3-2	3		JC63-04141A	COVER-DIMM; SL-M4020ND,ABS+PC,2.5,103.7,1	SNA	1
4	1		JC93-00835A	FRAME; SL-M4020ND,SEC,SEE	SNA	1
5	3		JC63-04137A	COVER-LEFT; ML-4210ND,HIPS,2.5,353.4,256,	SA	1
6	1		JC44-00096D	SMPS-V2; ML-3200,PSPN Type2 V2,Flyback,77	SA	1
7	2		JC92-02832J	PBA MAIN; SL-M4020ND,V2,NON-MD,A1500	SA	1

Exploded Views and Parts List

No.	Lvl.	Loc.	Material Code	Description & Specification	SNA	Qty.
8	1		JC90-01232A	DUPLEX; ML-4210ND,SEC	SA	1
9	2		JC91-01024A	FUSER; ML-3700,SEC,WORLD,220V	SA	1
10	2		JC93-00334A	FRAME-REAR; ML-3710,SEC,WORLD	SA	1
11	2		JC95-01303C	COVER-REAR; SL-4070FR,SEC	SA	1
12	1		JC97-04065A	LSU; ML-3750,SEC,Single,A4(Ltr),600,S1,78	SA	1
13	1		JC95-01842M	COVER-TOP; SL-M4020ND,SEC	SA	1

## 2. COVER-FRONT

### Exploded View

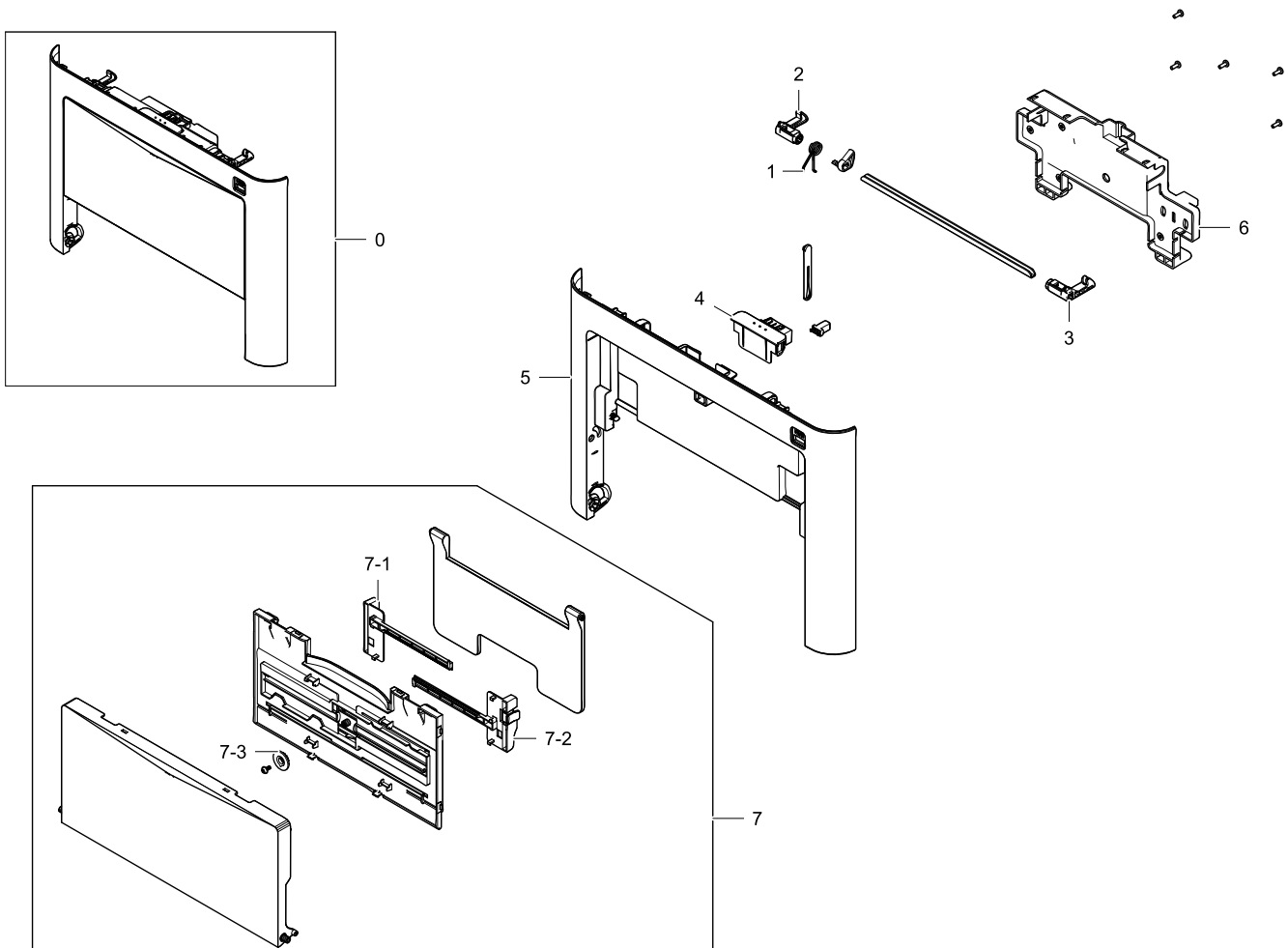

### Parts List

No.	Lvl.	Loc.	Material Code	Description & Specification	SNA	Qty.
0	1		JC95-01840C	COVER-FRONT; SL-M3820ND,SEC,SPLIT GRAY	SA	1
1	2		6107-003474	SPRING-TS; SWPB,1.0,12.1,12.1,3.05,3.05	SNA	1
2	2	J3642	JC64-00368A	LOCKER-FRONT_R; CLP-310,POM,BLACK,D-Type	SA	1
3	2	J3641	JC64-00367A	LOCKER-FRONT_L; CLP-310,POM,BLACK,D-Type	SA	1
4	2		JC64-00888A	BUTTON-FRONT; ML-4210ND,ABS,62.1,SPLIT BR	SNA	1
5	2		JC63-04134A	COVER-FRONT; ML-4210ND,HIPS,2.5,365.6,265	SNA	1
6	2		JC63-04192A	COVER; ML-4210ND,HIPS,2,234.2,119.61,SPLI	SNA	1
7	2		JC90-01037B	MP-GUIDE TRAY; ML-4210ND,SEC	SA	1
7-1	3		JC70-00561B	ADJUST-MP_LEFT; ML-3710,ABS,119.2,57.4,IC	SNA	1

Exploded Views and Parts List

---

No.	Lvl.	Loc.	Material Code	Description & Specification	SNA	Qty.
7-2	3		JC70-00562B	ADJUST-MP_RIGHT; ML-3710,ABS,120.2,57.4,I	SNA	1
7-3	3	C3718	JC66-00387A	GEAR-RACK_PINION; ML-1710,POM,0.7,WHT	SNA	1

### 3. COVER-TOP

#### Exploded View

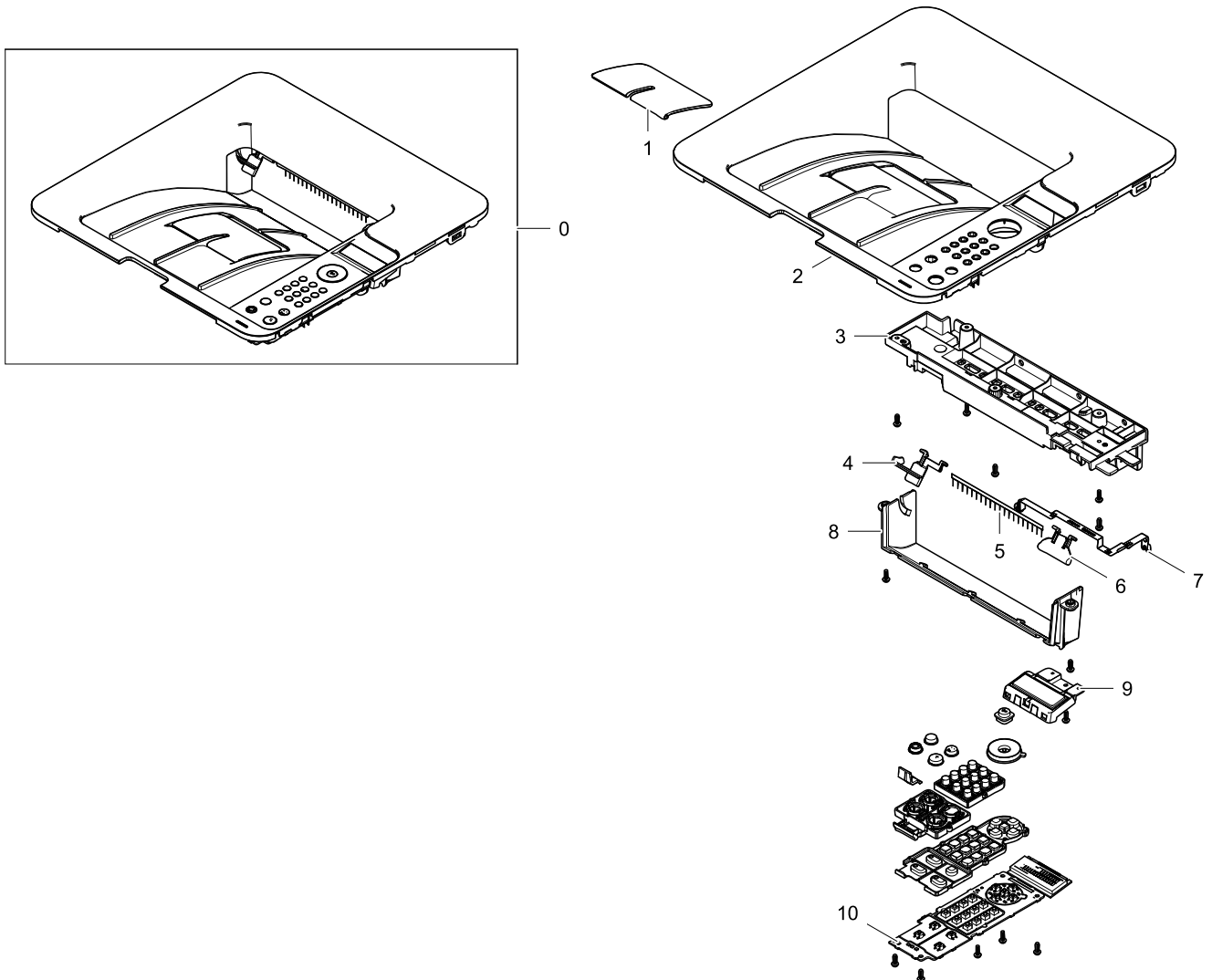

#### Parts List

No.	Lvl.	Loc.	Material Code	Description & Specification	SNA	Qty.
0	1		JC95-01842K	COVER-TOP; SL-M4020ND,SEC,SPLIT GRAY,GRAP	SA	1
1	2		JC61-05514A	STACKER-MAIN; CLP-680ND,ABS,2.2,100.1,73,	SA	1
2	2		JC63-04143F	COVER-TOP; SL-M4020ND,ABS,2.5,361.33,363.	SNA	1
3	2		JC63-04185A	COVER-PATH; SL-M4075FR,HIPS,HIPS-5197	SNA	1
4	2		JC61-04098A	STACKER-BIN_FULLL; Magpie,PC,2,48.54,35.2,	SA	1
5	2		JC67-00055B	BRUSH-ANTISTATIC; SCX-4833FD,AL+THUNDERON	SA	1
6	2	F5252	JC72-01343A	PMO-SUB_M_STACKER; ML-1520,PC,39*25.5*3.5	SNA	1
7	2		JC63-04130A	GROUND-EXIT; ML-4210ND,STAINLESS-ST304,0	SNA	1

Exploded Views and Parts List

---

No.	Lvl.	Loc.	Material Code	Description & Specification	SNA	Qty.
8	2		JC63-04136A	COVER-EXIT; SL-M4020ND,ABS+PC,2.5,250,62.	SNA	1
9	2		JC67-00708A	CAP-WINDOW_LCD; SL-M4025ND,PC,3022U,CLEAR	SNA	1
10	2		JC92-02608A	PBA-OPE; ML-4210ND,SEC,5V,2LINE_LCD,2L,CE	SA	1

## 4. FRAME-REAR

### Exploded View

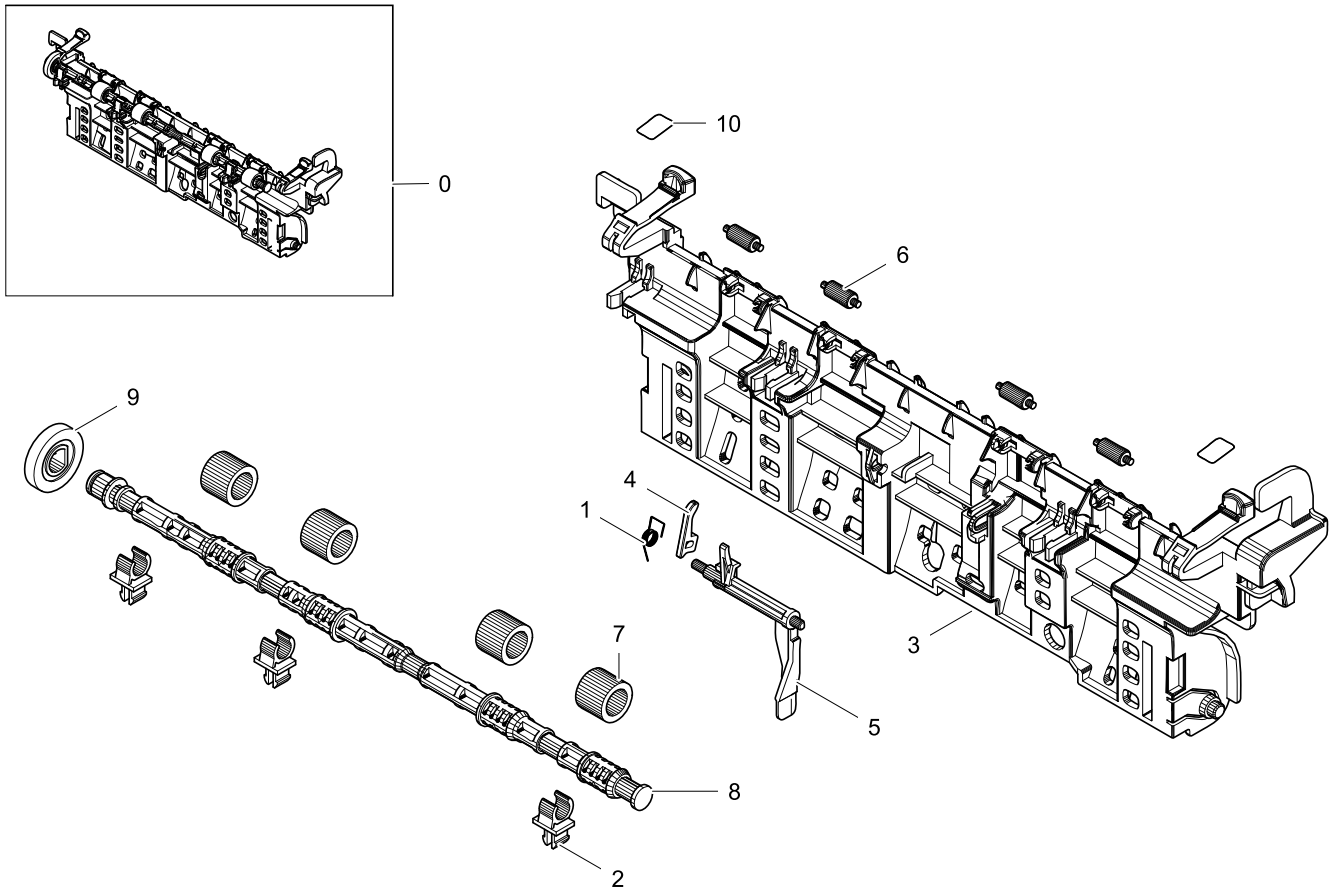

### Parts List

No.	Lvl.	Loc.	Material Code	Description & Specification	SNA	Qty.
0	2		JC93-00334A	FRAME-REAR; ML-3710,SEC,WORLD	SA	1
1	3		6107-002670	SPRING-ETC; SUS304,PI0.2,ID4.5,OD4.9,8.1,	SNA	1
2	3	H1255	JC61-02158A	BUSH-TX; ML-3471ND/SEE,POM(M90-44),2.5,16	SNA	3
3	3		JC61-04084A	GUIDE-REAR; ML-3700ND,PC,2.0t,PATH	SNA	1
4	3		JC61-04133A	HOLDER-ACTUATOR; ML-3700,TEFLON,2.0,17.4	SNA	1
5	3		JC66-02774A	ACTUATOR-EXIT; ML-3700ND,NYLON,2.0t,46.7,	SA	1
6	3	L4458	JC66-01661A	ROLLER-IDLE_EXIT; ML-2851ND,PFA	SNA	4
7	3		JC66-02955A	ROLLER-SILICON_EXIT; ML-3700,SILICON	SA	2
8	3		JC66-02773A	SHAFT-EXIT_F/UP; ML-3700ND,PET+GF45,236.4	SNA	1

Exploded Views and Parts List

---

No.	Lvl.	Loc.	Material Code	Description & Specification	SNA	Qty.
9	3		JC66-02777A	GEAR-EXIT_Z19; ML-3700ND,POM,1,19,NTR,21.	SNA	1
10	3		JC68-02610A	LABEL-ONE TOUCH; ML-3700,WHITE PET,0.1,7,	SNA	2



## 5. FUSER

### Exploded View

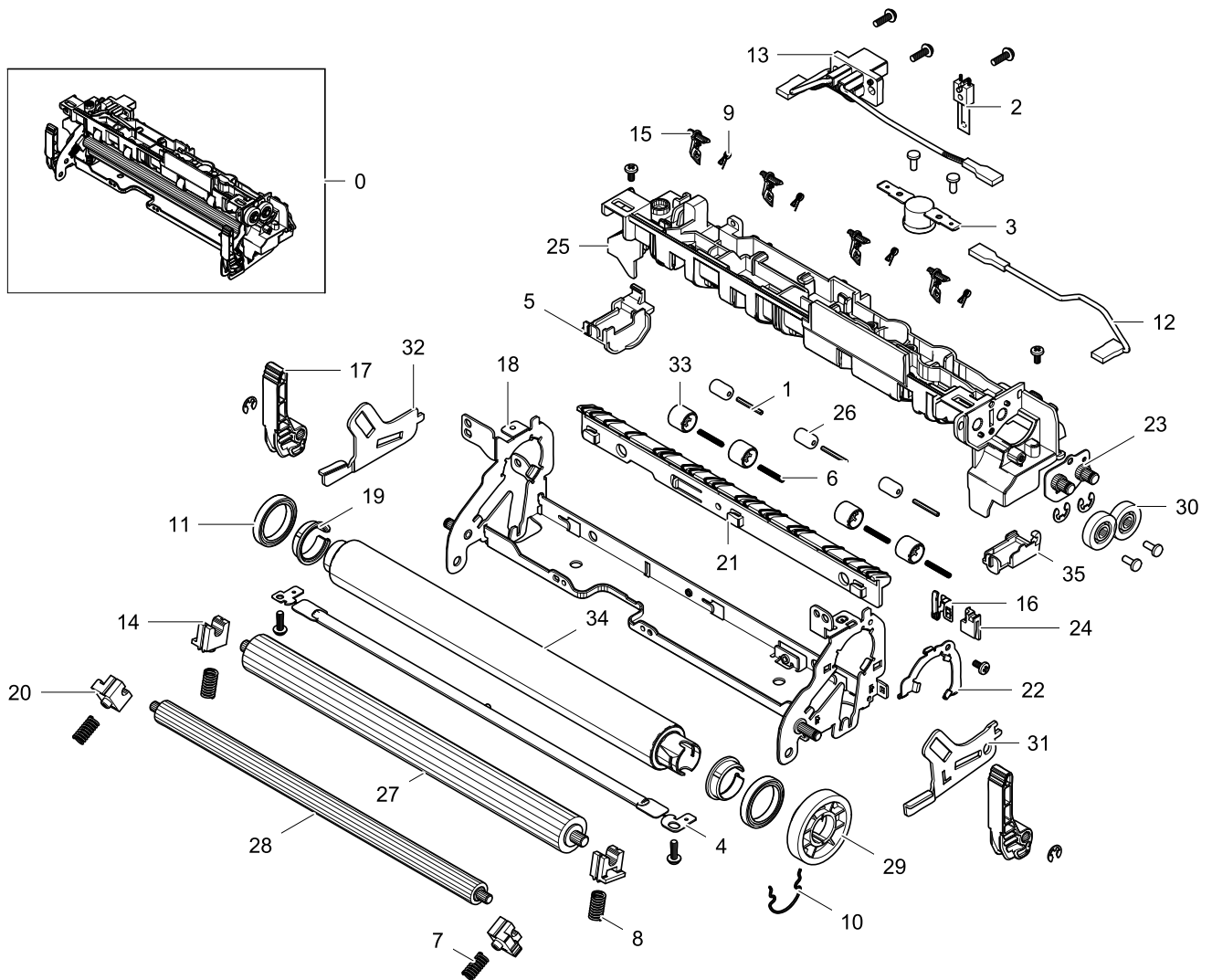

### Parts List

No.	Lvl.	Loc.	Material Code	Description & Specification	SNA	Qty.
0	1		JC91-01024A	FUSER; ML-3700,SEC,WORLD,220V	SA	1
1	2	C7178	JC70-20901A	SHAFT; ML-5000A,STAINLESS-ST303,17.2,4,P	SNA	1
2	2		1404-001640	THERMISTOR-NTC ASSY; 7KOHM,3370K,0.3mW/C,	SA	1
3	2		4712-001091	THERMOSTAT; AC125/250V,195+-5100	SNA	1
4	2		4713-001565	LAMP-HALOGEN; 230V,850W	SA	1
5	2		JC67-00499A	CAP-LAMP_R; ML-3700DN,PET+GF30,BK	SNA	1
6	2		6107-001188	SPRING-ETC; SUS304,ANNEALING,PI0.46,D1.84	SA	2
7	2	L7452	6107-001246	SPRING-CS; SWP B,PI0.9,D5.8,L15.5,ID4.9,O	SNA	2
8	2	L7453	6107-001267	SPRING-CS; SWP-B,PI1.0,D5.9,L17,ID4.9,OD6	SA	2

Exploded Views and Parts List

No.	Lvl.	Loc.	Material Code	Description & Specification	SNA	Qty.
9	2		6107-002817	SPRING-ETC; SUS304,0.35,0.29,3.2,3.78	SA	4
10	2		6107-002818	SPRING-ETC; SUS304,1.0,21.45	SA	1
11	2		6601-001725	BEARING-BALL; SB6704ZZ,ID20,OD27,T4.0	SA	2
12	2		JC39-01487A	HARNESS-FUSER JOINT; ML-3710,UL3122,1 pin	SA	1
13	2		JC39-01488A	HARNESS-FUSER CON; ML-3710,UL3122,2 pin,W	SA	1
14	2	H1241	JC61-01960A	BUSH-PR_1ST; ML-3471ND/SEE,PPS,3,16,BLACK	SNA	2
15	2	I6177	JC61-02154A	GUIDE-CLAW; ML-3471ND,PTFE,13.20,16.57,BR	SNA	4
16	2		JC63-02885A	GROUND-PR_M; ML-3700ND,SUS,0.2,GROUND/UNC	SNA	1
17	2		JC61-04085A	HOLDER-JAM; ML-3700ND,PC	SA	2
18	2		JC61-04092A	FRAME-FUSER; ML-3700,EGI-SECC,NATURAL,1.2	SNA	1
19	2		JC61-04093A	BUSH-HR; ML-3700,PPS,17.4,19.9,DARK BLUE	SA	2
20	2		JC61-04095A	BUSH-PR_2ND; ML-3700,PPS(RFKB-9),5.1,BLAC	SA	2
21	2		JC61-04096A	GUIDE-INPUT; ML-3700ND,PET+GF,210.7,GF30%	SNA	1
22	2		JC61-04114A	BRACKET-BEARING; ML-3700ND,secc,0.8t	SNA	1
23	2		JC61-04122A	BRACKET-GEAR; ML-3700ND,SECC,0.8,31	SNA	1
24	2	I6250	JC61-02631A	GUIDE-GROUND_PR; SCX-5135ND,PC,1.5T,BLACK	SNA	1
25	2		JC63-02899A	COVER-FUSER; ML-3700ND,PET+GF,295.59,BLAC	SNA	1
26	2	F8911	JC66-01312A	ROLLER-IDLE; SCX-4521F,PTFE	SNA	1
27	2	L4523	JC66-01663A	ROLLER-PRESSURE; ML-2851ND,12,SUM22 or SU	SA	1
28	2	L4534	JC66-01664A	ROLLER-PRESSURE_2ND; ML-2851ND,8,SUM22 or	SA	1
29	2		JC66-02775A	GEAR-FUSER; ML-3700ND,PPS,1,36,38.0	SC	1
30	2		JC66-02776A	GEAR-IDLE-EXIT; ML-3700ND,NYLON,1,17,19	SNA	2
31	2		JC66-02795A	LEVER-LINK_JAM_L; ML-3700ND,SECC,1.6t,WHI	SA	1
32	2		JC66-02796A	LEVER-LINK_JAM_R; ML-3700ND,SECC,1.6t,WHI	SA	1
33	2		JC66-02844A	ROLLER-IDLE_EXIT; ML-3700,PTFE	SA	2
34	2		JC66-02846A	ROLLER-HEAT; ML-3700,24.75,AL3304-H14 or	SA	1
35	2		JC67-00498A	CAP-LAMP_L; ML-3700DN,PET+GF30,BK	SNA	1

## 6. DUPLEX

### Exploded View

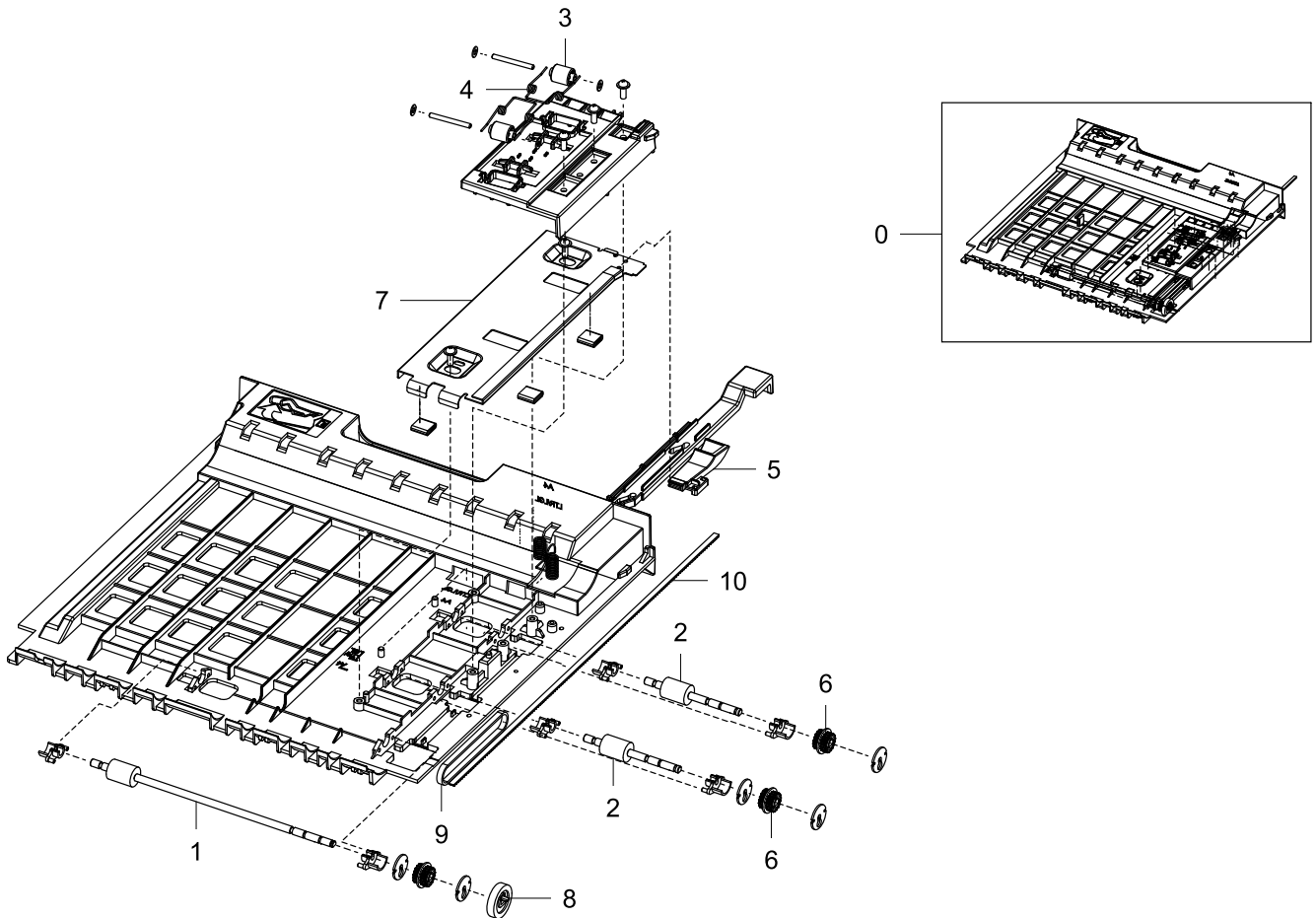

### Parts List

No.	Lvl.	Loc.	Material Code	Description & Specification	SNA	Qty.
0	1		JC90-01031C	DUPLEX; ML-4210ND,SEC	SA	1
1	2	F8873	JC66-01657A	ROLLER-FEED_DUP2; ML-2851ND,NBR,SUM22,4	SNA	1
2	2	L4423	JC66-00901A	ROLLER-FEED_DUP; ML-3560,NBR,SUM22,4	SNA	2
3	2		JC66-02980A	ROLLER-DUPLEX_IDLE; ML-5015ND,POM,SW-01	SNA	2
4	2		6107-003256	SPRING-TS; SUS304,NO,0.55,4.05,3.5,2-5.8,	SNA	2
5	2		JC61-04055A	GUIDE-PAPER_DUPLEX; ML-3700ND,PC,1.5,16.2	SNA	1
6	2	F7328	JC66-00899A	PULLEY-18_DUP; ML-3560,POM,HB,WHITE, 4.1	SNA	3
7	2		JC61-04053A	BRACKET-DUPLEX_ALIGN; ML-3700ND,SECC,0.6,	SNA	1
8	2	C3331	JC66-00038A	GEAR-EXIT F/DOWN; ML-4500,POM,0.8,BLACK,F	SNA	1

Exploded Views and Parts List

---

No.	Lvl.	Loc.	Material Code	Description & Specification	SNA	Qty.
9	2	A4233	6602-001588	BELT-TIMING GEAR; 32S2M152,CR+GF+NF,T3.2,	SNA	1
10	2	G9102	JC66-20901A	BELT-FLAT RUBBER; L280, W3.2, S2M, 140	SA	1

## 7. FRAME

### Exploded View

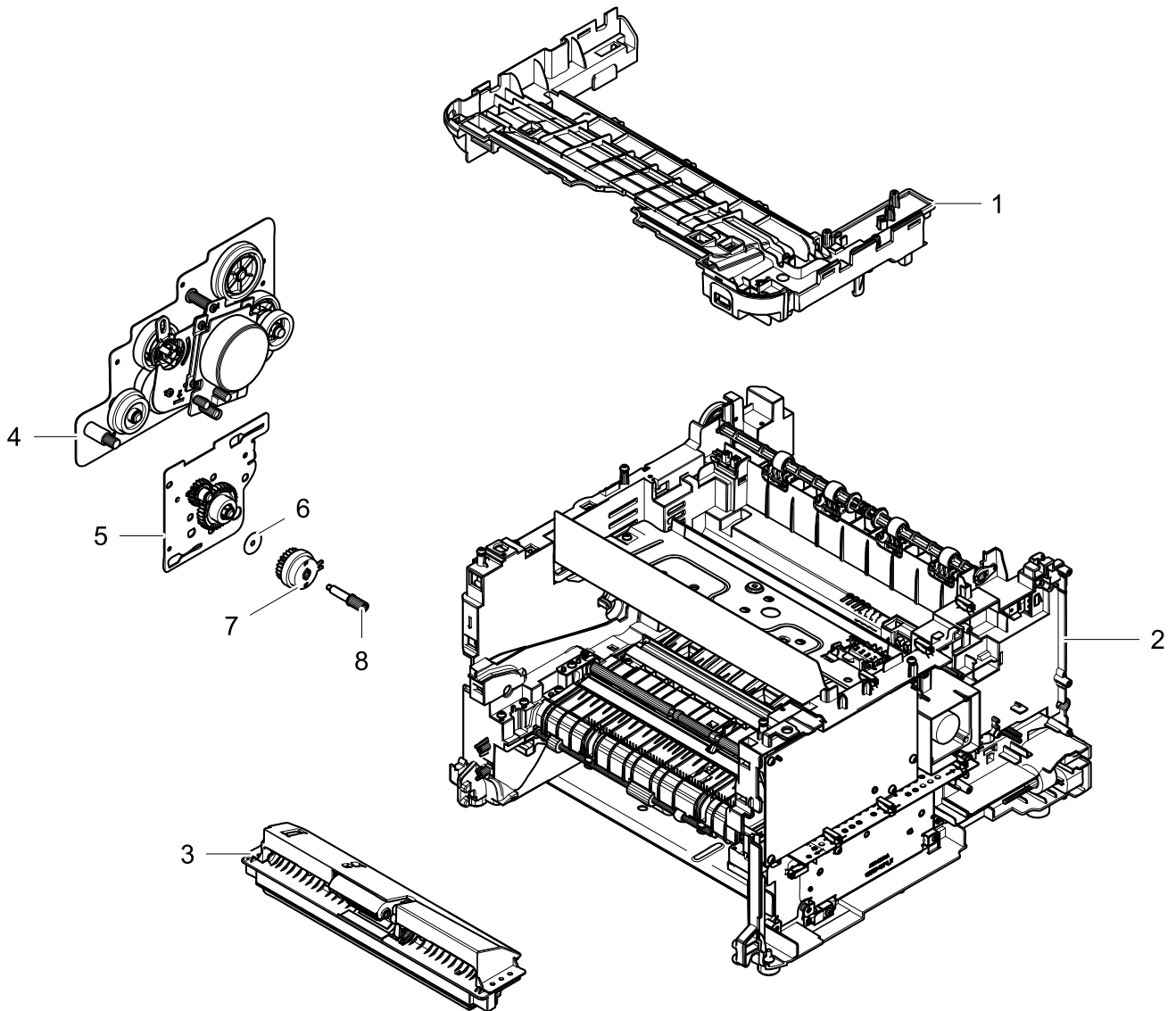

### Parts List

No.	Lvl.	Loc.	Material Code	Description & Specification	SNA	Qty.
1	2		JC63-04144A	COVER-TOP_INNER; SL-M4025ND,ABS,SPLIT GRA	SNA	1
2	2		JC93-00836A	FRAME-ETC; SL-M4020ND,SEC	SNA	1
3	2		JC90-01043C	MP; ML-4210ND,SEC	SA	1
4	2		JC93-00544B	DRIVE; ML-4210ND,SEC	SA	1
5	2		JC93-00545A	DRIVE-FEED; ML-3710	SA	1
6	2	G1111	JC60-00037A	SPACER-CLUTCH; ML-2851ND/XAA,POLY,ID4,OD1	SNA	1

Exploded Views and Parts List

---

No.	Lvl.	Loc.	Material Code	Description & Specification	SNA	Qty.
7	2		JC47-00033A	CLUTCH-ELECTRIC; 2.5,24,1,120mA,200Ohm	SA	1
8	2		JC66-02772A	SHAFT-FEED REGI; ML-3710ND,POM,35.5,8,NAT	SA	1

## 7.1. MP

### Exploded View

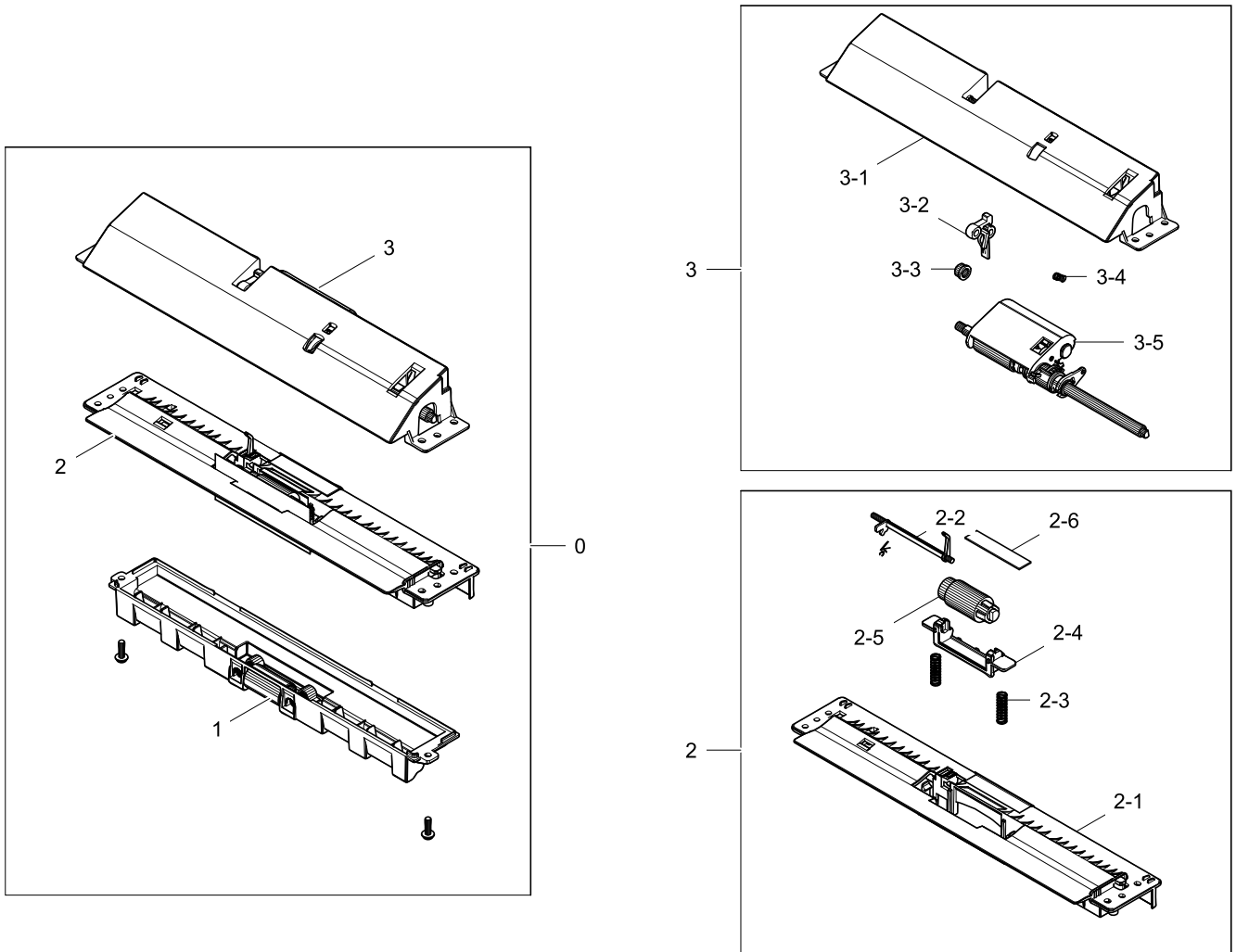

### Parts List

No.	Lvl.	Loc.	Material Code	Description & Specification	SNA	Qty.
0	2		JC90-01043C	MP; ML-4210ND,SEC	SA	1
1	3		JC90-01038C	MP-HOLDER IDLE; ML-4210ND,SEC	SNA	1
2	3		JC90-01039C	MP-LOWER; ML-4210ND,SEC	SNA	1
2-1	4		JC61-04061D	GUIDE-LOWER MP; SL-M4020ND,HIPS,54.6,261.	SNA	1
2-2	4		JC66-02766A	ACTUATOR-EMPTY_MP; ML-3710ND,PC,65.9,50.7	SA	1
2-3	4		6107-002776	SPRING-CS; SUS304,0.4,16,5.0,5.8	SA	2
2-4	4		JC61-04101A	HOLDER-RETARD_SHAFT; ML-3710,POM,12.2,67.	SNA	1
2-5	4		JC90-01032A	CASSETTE-ROLLER RETARD; ML-3710,SEE	SA	1
2-6	4	F9051	JC73-00141A	RPR-PAD CASSETTE; ML-1510,Urethan Sponge,	SA	1

Exploded Views and Parts List

No.	Lvl.	Loc.	Material Code	Description & Specification	SNA	Qty.
3	3		JC90-01040C	MP-UPPER; ML-4210ND,SEC	SNA	1
3-1	4		JC61-04058D	GUIDE-UPPER MP; SL-M4020ND,HIPS,48.5,262,	SNA	1
3-2	4		JC66-02767A	ACTUATOR-ARM_MP; ML-3700ND,POM,5,14.2,4,B	SA	1
3-3	4	F0104	JB72-00819A	BUSH; SCX-1110F,POM,NTR	SA	1
3-4	4		6107-002780	SPRING-ES; SUS304,PI0.24,L11.1,ID3.5,OD4	SA	1
3-5	4		JC90-01041C	MP-PICKUP; ML-4210ND,SEC	SNA	1



## 7.2. DRIVE

### Exploded View

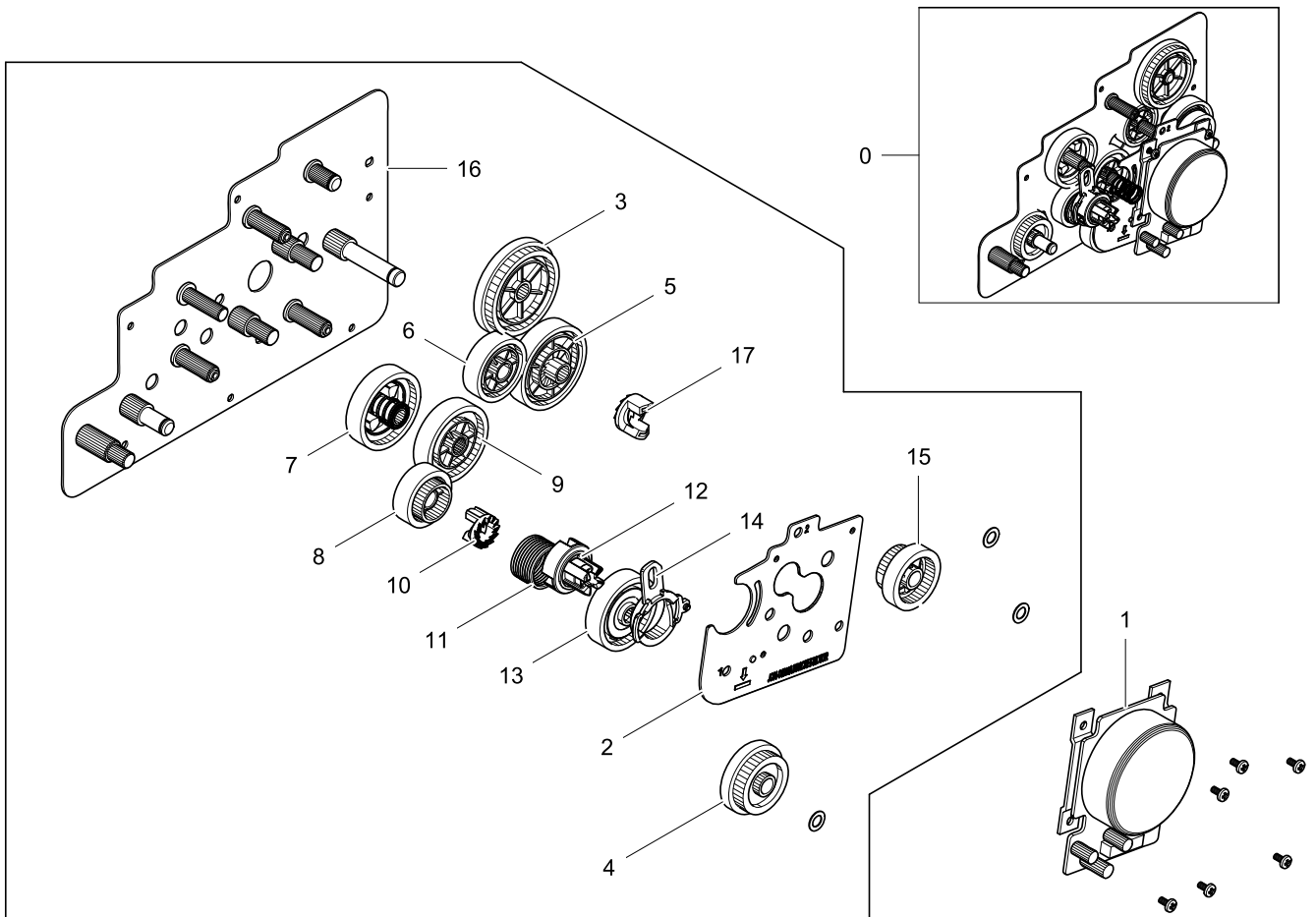

### Parts List

No.	Lvl.	Loc.	Material Code	Description & Specification	SNA	Qty.
0	2		JC93-00544B	DRIVE; ML-4210ND,SEC	SA	1
1	3		JC31-00075B	MOTOR BLDC; ML-4210ND,3/10,37,24,1200/190	SA	1
2	4		JC61-04918A	BRACKET-MOTOR; ML-3710,SECC,1.2,95,85	SNA	1
3	4		JC66-02779A	GEAR-EXIT 95-81; ML-3310,POM,0.5/0.5,95/8	SNA	1
4	4		JC66-02790A	GEAR-FEED 65-28; ML-3710,POM,0.5/1.0,65/2	SNA	1
5	4		JC66-02781A	GEAR-FUSER DR IN 79; ML-3710,POM,0.5,79,N	SNA	1
6	4		JC66-02785A	GEAR-IDLE 59; ML-3710,POM,0.5,59,BLACK,F2	SNA	1
7	4		JC66-02787A	GEAR-COUPLER 73; ML-3710,POM,0.5,73,BLACK	SNA	1
8	4		JC66-02788A	GEAR-OPC DR OUT 53; ML-3710,POM,0.5,53,BL	SNA	1
9	4		JC66-02786A	GEAR-IDLE 73; ML-3710,POM,0.5,73,BLACK,F2	SNA	1

Exploded Views and Parts List

No.	Lvl.	Loc.	Material Code	Description & Specification	SNA	Qty.
10	4		JC70-00589A	HUB-CLUTCH; ML-3710ND,POM,ID10.4,F20-02,N	SNA	1
11	4		6107-002785	SPRING-CS; SUS304WPB,D13,18.6,T1,ID11	SNA	1
12	4		JC67-00504A	COUPLER; ML-3710ND,POM,OD25,NATURAL,F20-0	SA	1
13	4		JC66-02789A	GEAR-OPC DR IN 69; ML-3710,POM,0.5,69,BLA	SNA	1
14	4		JC67-00503A	COUPLER-CAM; ML-3710ND,PC,NH-1035,BLK	SNA	1
15	4		JC66-02782A	GEAR-FUSER DR 29; ML-3710ND,PA66,1.0,29,B	SNA	1
16	4		JC61-04916A	BRACKET-GEAR; ML-3710,SECC,1.2,133,214	SNA	1
17	4	C3424	JC66-00340A	GEAR-HUB CLUTCH; POM,11.3,11.3,11.3,NW-02	SA	1

## 7.3. FRAME-ETC

### Exploded View

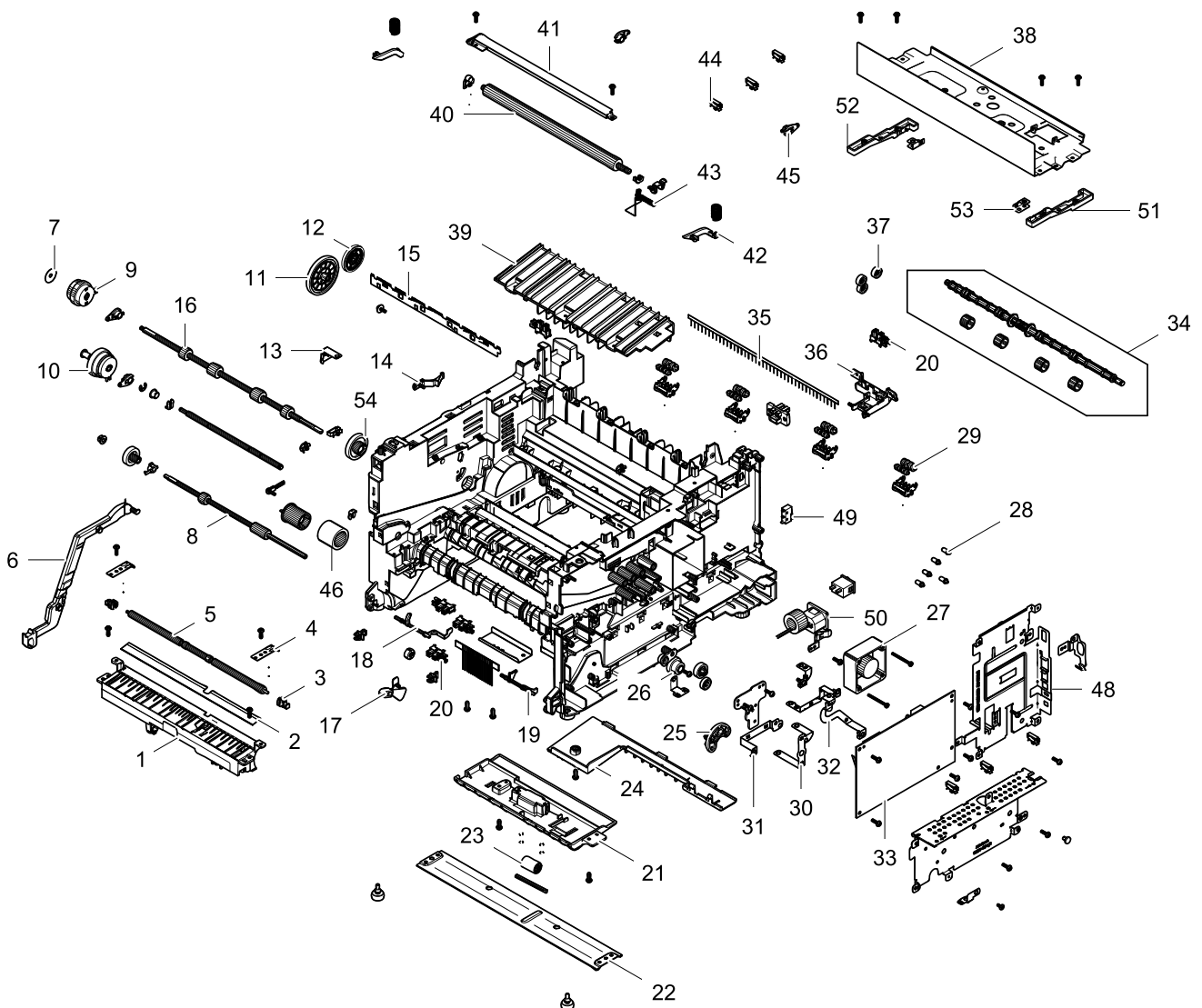

### Parts List

No.	Lvl.	Loc.	Material Code	Description & Specification	SNA	Qty.
1	3		JC61-04064A	GUIDE-FRAME DUPLEX; ML-3700,ABS,2.3,250,5	SA	1
2	3		JC63-02956A	SHEET-DUPLEX PATH; ML-3710,PET+TAPE NITTO	SA	1
3	3	A7646	JC61-00585A	BUSH-M-FEED IDLE; ML-1710,POM,2.1,4.2	SA	2
4	3	K7917	JC61-00914A	PLATE-P-PUSH BUSHING; SCX-4920N,EGI-SECC,	SNA	2
5	3	G0225	JC66-00527A	SHAFT-FEED IDLE; ML-1510,SUM 24L,223,8,ST	SNA	1
6	3		JC66-02770A	LEVER-COUPLING; ML-3710,PC,3.0,184.4,126.	SA	1
7	3	G1111	JC60-00037A	SPACER-CLUTCH; ML-2851ND/XAA,POLY,ID4,OD1	SNA	1

## Exploded Views and Parts List

No.	Lvl.	Loc.	Material Code	Description & Specification	SNA	Qty.
8	3		JC66-02797A	ROLLER-FEED; ML-3700,EPDM,SUM22,5	SA	1
9	3		JC47-00033A	CLUTCH-ELECTRIC; 2.5,24,1,120mA,200Ohm	SA	1
10	3		JC47-00036B	CLUTCH-ELECTRIC; 2.5,45,0.6,120mA,200Ohm	SA	1
11	3		JC66-02778A	GEAR-EXIT IDLE 96; ML-3310,POM,0.5,96,NTR	SA	1
12	3		JC66-02780A	GEAR-EXIT 65; ML-3310,POM,0.5,65,NTR,F20-	SNA	1
13	3		JC63-02875A	GROUND-BRKT GEAR; ML-3700,SUS,0.2,18,18,G	SNA	1
14	3	F4182	JC72-00983A	LOCK SLIDER; ML-1710,POM(DELIN 900P),WHT	SA	2
15	3	E9623	JC61-00604A	PLATE-P-SAW; ML-1400,SUS304,0.15,15.1,216	SNA	1
16	3		JC66-02834A	ROLLER-FEED REGI; ML-3200,EPDM,SUM22,6	SA	1
17	3		JC66-02762A	ACTUATOR-EMPTY; ML-3710,POM,3.0,43.1,31.2	SA	1
18	3		JC66-02763A	ACTUATOR-REGI; ML-3710,PC+GF,3.0,30.6,21.	SA	1
19	3		JC66-02764A	ACTUATOR-FEED; ML-3710,PC+GF,3.0,17.5,20.	SA	1
20	3	E9322	0604-001393	PHOTO-INTERRUPTER; TR,75mW,BGA,TR	SA	5
21	3	I4945	JC61-02752A	FRAME-DUPLEX PATH_EX; ML-2851ND,HIPS,BLAC	SNA	1
22	3		JC61-04069A	PLATE-FRAME BOTTOM; ML-3700,EGI-SECC,1.0,	SNA	1
23	3	L4477	JC66-01022A	ROLLER-M_IDLE SCF; SCX-6345N,POM,500CL	SA	1
24	3	A8155	JC67-00291A	CAP-HARNESS; ML-2851ND,ABS V0,2,241.1,76.	SNA	1
25	4	H1141	JC61-02265A	BRACKET-SWING DUPLEX; ML-2851ND/XAA,PPS,5	SNA	1
26	3	I5856	JC66-01651A	GEAR-RDCN 23/23; ML-2851ND/XAA,POM,0.6/0.	SNA	1
27	3		JC31-00146A	FAN; Type4,24,100mA,2.794mmH20,0.374m <sup>3</sup> /m	SA	1
28	4	C6756	JC70-40912A	SHAFT; ML-5000A,STAINLESS-ST303,6,NI,T4.	SNA	5
29	3		JC93-00324A	FRAME-ROLLER DECURL; ML-3700	SA	2
30	3		JC63-02874A	GROUND-BRKT PAPER; ML-3700,SUS,0.2,54,43.	SNA	1
31	3		JC63-02876A	GROUND-HVPS; ML-3700,SUS,0.2,74.3,15,GROU	SNA	1
32	3		JC63-02877A	GROUND-BRACKET LSU; ML-3700,SUS,0.2,48.5,	SNA	1
33	3		JC44-00197A	HVPS; 24V,21.6V~27.6V,MAX 5KV,MAX-2KV,600	SA	1
34	3		JC93-00323A	FRAME-ROLLER EXIT; ML-3700	SNA	1
35	3	H1148	JC67-00055A	BRUSH-ANTISTATIC 531P; SF-531P,AL+THUNDER	SA	1
36	3		JC61-04067A	HOLDER-EXIT SENSOR; ML-3710,ABS,2,45.5,44	SA	1
37	4	I5945	JC66-01635A	GEAR-SWING DR 19; ML-2851ND/XAA,POM,0.6,1	SNA	3

No.	Lvl.	Loc.	Material Code	Description & Specification	SNA	Qty.
38	3		JC61-04915A	BRACKET-LSU; ML-3750ND,EGI-SECC,1.0T,305,	SNA	1
39	3		JC61-04091A	GUIDE-TR RIB; ABS,2.3,239.2,79.8,BLACK,PA	SNA	1
40	3		JC66-02842A	ROLLER-TRANSFER; Magpie,15.0 (mm),NBR+ECO	SA	1
41	3	K7736	JC61-02236A	PLATE-EARTH-TRANSFER; ML-2851ND,EGI-SECC,	SNA	1
42	3	F4594	JC72-00985A	CORE ROTOR; ML-1710,POM(M90-44),BLK	SA	1
43	3		JC65-00047A	TERMINAL-TR; ML-3700,SUS304,0.5PI	SA	1
44	3	L9053	6502-001130	CABLE CLAMP; DACS-3N,16.67 * 4,Nylon66,BL	SA	8
45	3	K8195	JC72-41191B	SHAFT; ML-2150,POM,BLK,DE8903	SNA	4
46	4		JC73-00340A	RUBBER-PICK UP; ML-3700,EPDM80%+IR20%	SA	1
48	3		JC63-04078A	SHIELD-CONTROLLER; SL-M4025ND,EGI-SECC,0.	SNA	1
49	3		JC39-01469A	HARNESS-REARCOVER & BINFULL SENSOR; ML-3710	SA	1
50	2		JC39-01482A	HARNESS-AC INLET-1; ML-3710,UL1617,3pin,W	SA	1
51	3		JC61-04912A	HOLDER-BRKT_LSU_RIGHT; ML-3750ND,PC+GF,T2	SNA	1
52	3		JC61-04911A	HOLDER-BRKT_LSU_LEFT; ML-3750ND,PC+GF,T2.	SNA	1
53	3		JC63-03449A	GROUND-BRKT EXTENSION; ML-3750ND,SUS,0.2,	SNA	2
54	3		JC66-03311A	GEAR-FEED IDLE 29; ML-3710,POM,1,29,BLACK	SNA	1

# 8. CASSETTE

## Exploded View

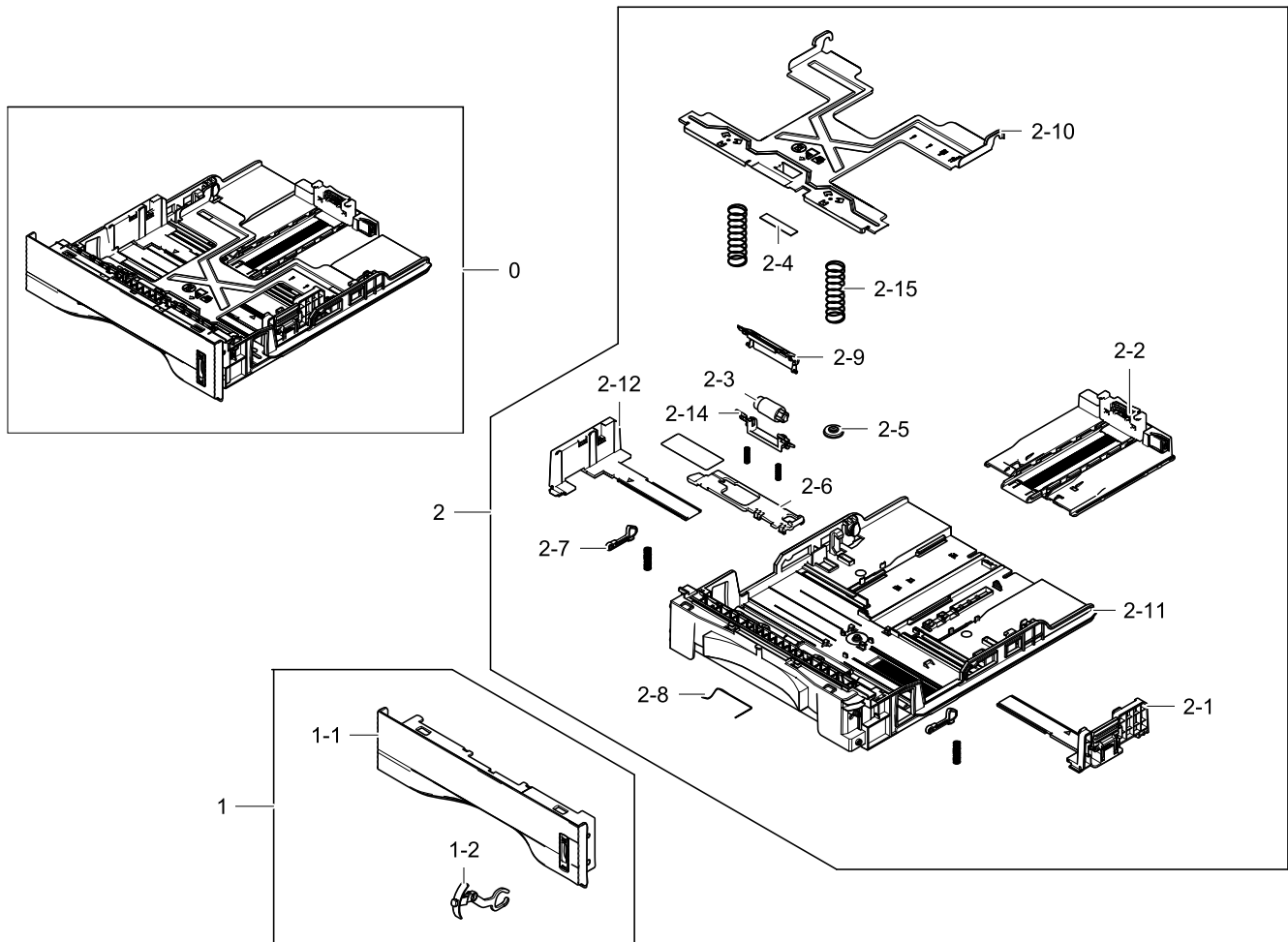

## Parts List

No.	Lvl.	Loc.	Material Code	Description & Specification	SNA	Qty.
0	1		JC90-01143B	CASSETTE; ML-4210ND,SEC	SA	1
1	2		JC90-01174D	CASSETTE-COVER HANDLE; ML-4210ND,SEC	SNA	1
1-1	3		JC64-00890A	HANDLE-CASSETTE; ML-4210ND,HIPS,2.5,287.4	SNA	1
1-2	3		JC64-00609D	INDICATOR-PAPER; ML-4210ND,ABS,2.5,Brown	SNA	1
2	2		JC90-01173C	CASSETTE-FRAME; ML-4210ND,SEC	SNA	1
2-1	3		JC90-01106A	CASSETTE-GUIDE RIGHT; ML-2955ND,SEE	SA	1
2-2	3		JC90-01105C	CASSETTE-GUIDE REAR; ML-4210ND,SEC	SNA	1
2-3	3		JC90-01063B	CASSETTE SUB-RETARD; ML-4210ND,EPDM	SA	1
2-4	3	F9051	JC73-00141A	RPR-PAD CASSETTE; ML-1510,Urethan Sponge,	SA	1
2-5	3		JC66-03004A	GEAR-PINION; ML-2950ND,POM,0.5,32,3.9,WHI	SNA	1

No.	Lvl.	Loc.	Material Code	Description & Specification	SNA	Qty.
2-6	3		JC64-00611A	LOCKER-PLATE; ML-3710,POM,NTR,138.5,29.5	SNA	1
2-7	3		JC64-00610A	LOCKER-CASSETTE; ML-3710,POM,NTR,41.5,15	SNA	2
2-8	3		JC63-02932A	GROUND-CASSETTE; SUS,0.2,UNC	SNA	1
2-9	3		JC90-01279B	CASSETTE SUB-COVER; M4020,SEC	SA	1
2-10	3		JC61-04922A	PLATE-KNOCK UP; ML-3310ND,EGI-SECC,0.8,26	SNA	1
2-11	3		JC61-04920D	FRAME-CASSETTE; ML-4210ND,ABS,Split gray,	SNA	1
2-12	3		JC61-04397A	GUIDE-ADJUST_L; ML-2950ND,ABS,2.0,135.5,9	SA	1
2-14	3		JC61-04327A	HOLDER-ROLLER; ML-3710ND,ABS,2,66,39,HB	SNA	1
2-15	3		6107-002779	SPRING-CS; SWP,ZINC,0.9,17.9,56.3,17,18.8	SA	2