

KONICA MINOLTA

PARTS GUIDE MANUAL

SEPTEMBER 2007

*bizhub 181/bizhub 211/bizhub
220/bizhub 7621/bizhub 7622
A08E*

INFORMATION FOR PARTS GUIDE MANUAL

To find correct Parts No., refer to the "HOW TO MAKE THE BEST USE OF THIS MANUAL" in the following page.

HOW TO MAKE THE BEST USE OF THIS MANUAL

- 1 When you order, please check the proper figures beforehand that are on Our Parts Guide Manual, and order with the appropriate figures.
- 2 For screws, Nuts, Washers, retaining rings and Pins which are used in this model, one letter is shown on the Standard parts column of Parts list and exploded diagrams.
- 3 In order to maintain safety of the product, some specific parts composed of this product are set up as "essential safety parts".
- 4 The assigned parts number for the "essential safety parts" is indicated as "SP00-****".
When replacing these parts, follow precautions for disassembling and installing which are listed in the Service Manual.
Do not use any parts that are not set up as
- 5 ♣ means that there are exclusive parts for each destination.
Please check the appropriate destination when you order.
- 6 Revision Mark
Marked as ▲ on the illustration shows that the revision has been made.
- 7 All rights reserved. (any reprints or quotations are prohibited.)
Use of this parts guide manual should be strictly supervised to avoid disclosure of confidential information.

SYSTEM OUTLINE

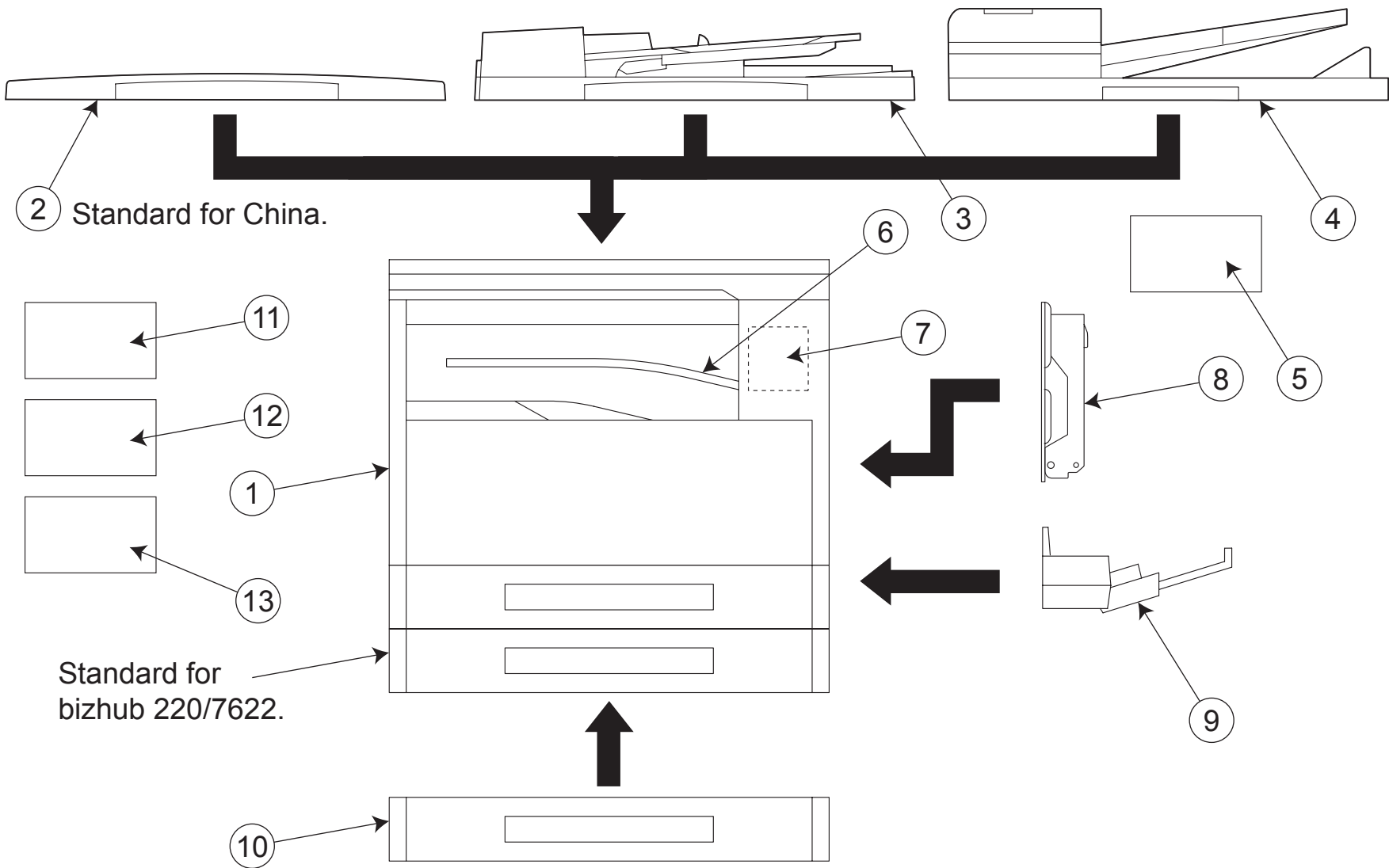

GENERAL CONTENTS

No.	Description	Model
1	DIGITAL MFP B/W	bizhub 181/bizhub 211/bizhub 220/bizhub 7621/ bizhub 7622
2	DOCUMENT FEEDER	DF-502
3	DOCUMENT FEEDER	DF-605
4	OTHER OPTION	MK-501
5	OTHER OPTION	SF-501
6	STACKER	JS-503
7	DUPLEX	AD-504
8	PAPER FEEDER	MB-501
9	PAPER FEEDER	PF-502
10	OTHER OPTION	IC-206
11	OTHER OPTION	NC-503
12	FAX CONTROLLER	FK-506

DIAGRAM OF MAIN PARTS SECTION

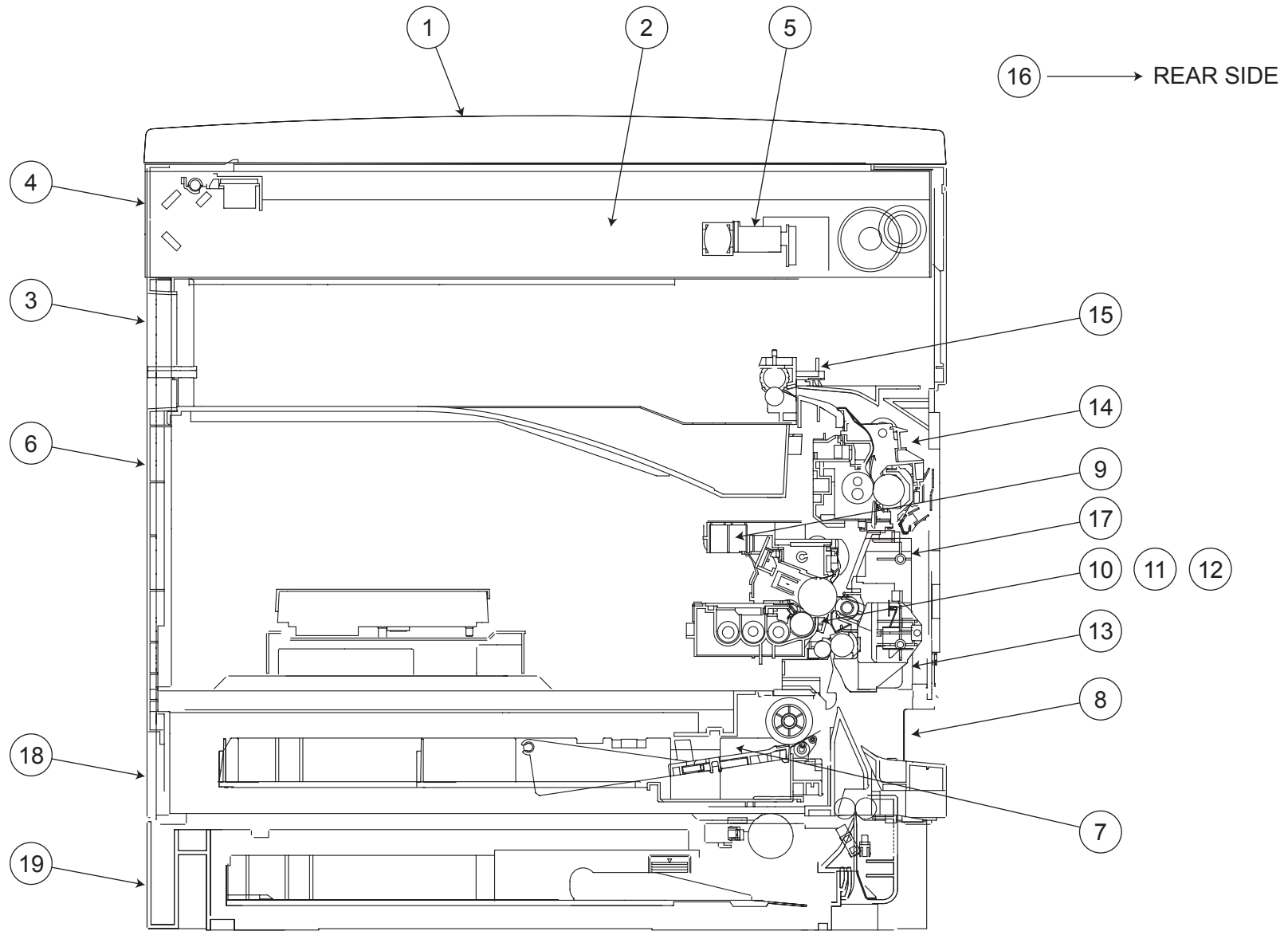

CONTENTS

No.	DESCRIPTION	PAGE No.
1	ORIGINAL COVER	P1
2	CONTROL PANEL	P2
3	HOUSING	P3
4	IR SECTION	P4 P5
5	SLIDER SECTION	P6
6	FRAMES	P7 P8
7	PAPER TAKE-UP SECTION	P9 P10
8	MANUAL FEED SECTION	P11
9	HOPPER SECTION	P12
10	CHARGE SECTION	P13
11	DEVELOPING SECTION	P14
12	CLEANER SECTION	P15
13	TRANSPORT SECTION	P16
14	FUSING SECTION	P17
15	PAPER EXIT SECTION	P18
16	DRIVE SECTION	P19
17	ELECTRICAL COMPONENTS	P20
18	CASSETTE SECTION	P21 P22
19	PAPER FEEDER UNIT	P23 P24 P25
20	WIRING ACCESSORIES AND JIGS	P26
21	ACCESSORY PARTS	P27

INDEX

Parts No.	Page No.
0910 5507 12	15-17
0996 3022 01	25-29
0996 3023 01	25-31
1033 4402 01	3-24
1038 4006 01	26-8
1053 4812 01	26-7
1129 7303 01	8-10
1129 7303 01	9-3
1134 3043 01	18-5
1139 1703 02	1-6
1139 1704 14	1-5
1139 1706 01	1-7
1139 3169 01	24-6
1139 5015 01	12-4
1139 5018 04	12-18
1139 5022 01	12-10
1139 5026 01	12-12
1139 5249 01	14-41
1139 5250 01	14-40
1139 5730 01	12-31
1144 3097 03	22-4
1144 7910 01	26-16
1151 5023 01	12-13
1151 5032 01	12-20
1151 5033 02	12-19
1151 7383 01	21-17
1156 4118 02	15-20
1164 1031 01	3-2
1164 3003 01	22-17
1164 3004 03	22-19
1164 3005 02	22-18
1164 3020 03	10-24
1164 3020 03	23-12
1164 3027 01	10-14
1164 3045 01	22-24
1164 3047 02	22-11
1164 3049 02	22-23
1164 3054 01	10-27
1164 3061 01	22-12
1164 3062 01	22-13

Parts No.	Page No.
1164 3508 01	9-32
1164 3509 01	9-16
1164 3515 01	9-31
1164 4202 04	16-27
1164 4206 02	16-21
1164 4207 01	16-22
1164 4222 01	16-20
1164 5765 01	17-16
1165 4307 01	13-3
1165 4310 01	13-6
1165 5326 02	12-14
1171 1126 01	1-1
1171 1127 03	1-3
1174 5010 01	12-17
1200 1346 12	12-7
4002 5042 02	9-9
4002 5042 02	14-38
4002 7306 01	25-13
4004 3006 03	22-5
4011 0112 02	16-25
4011 2504 01	24-17
4011 3002 01	21-2
4011 3005 01	21-1
4011 3007 03	22-22
4011 3008 06	22-16
4011 3009 01	22-21
4011 3012 01	10-23
4011 3020 01	22-31
4011 3021 01	22-30
4011 3205 01	11-11
4011 3515 01	16-10
4011 5858 01	16-32
4011 5858 01	17-4
4011 7313 01	27-4
4011 7314 01	27-4
4021 0162 02	12-25
4021 0163 05	14-5
4021 0165 03	14-7
4021 0166 02	15-28
4021 0202 03	14-21

Parts No.	Page No.
4021 0204 01	19-33
4021 0752 01	14-6
4021 1009 01	3-27
4021 2014 12	8-3
4021 2018 01	9-17
4021 2019 02	16-12
4021 2020 01	20-5
4021 2025 01	11-18
4021 2031 01	9-19
4021 2101 01	9-10
4021 2103 02	9-6
4021 2106 01	9-5
4021 2110 01	8-11
4021 2307 01	16-33
4021 2316 01	9-26
4021 2501 01	19-20
4021 2502 01	19-5
4021 2503 01	19-21
4021 2504 01	19-25
4021 2505 01	19-6
4021 2509 01	19-24
4021 2510 01	19-4
4021 2511 01	19-3
4021 2512 01	19-2
4021 2517 01	19-23
4021 2519 01	19-8
4021 2533 03	19-27
4021 2538 01	19-7
4021 2540 01	19-18
4021 2541 01	19-22
4021 2542 01	19-19
4021 2547 02	19-17
4021 3001 28	21-10
4021 3002 05	22-34
4021 3004 01	23-10
4021 3009 01	22-32
4021 3013 02	22-3
4021 3014 02	22-8
4021 3019 01	21-8
4021 3020 01	21-9

Parts No.	Page No.
4021 3031 13	21-7
4021 3032 12	21-6
4021 3035 02	21-4
4021 3036 01	21-5
4021 3037 02	22-1
4021 3103 01	11-23
4021 3104 01	11-2
4021 3105 01	11-25
4021 3106 01	11-24
4021 3107 01	11-19
4021 3108 01	11-22
4021 3504 01	10-4
4021 3505 01	9-18
4021 3512 12	9-30
4021 3513 12	9-15
4021 4101 02	13-19
4021 4102 02	13-13
4021 4103 02	13-10
4021 4104 02	13-17
4021 4105 01	13-11
4021 4106 01	13-12
4021 4107 01	13-20
4021 4108 01	13-16
4021 4109 01	13-9
4021 4209 02	16-29
4021 4219 01	16-19
4021 4302 02	13-5
4021 4351 06	13-25
4021 4352 06	13-14
4021 4362 01	13-24
4021 4367 01	13-22
4021 4368 02	15-16
4021 5203 03	14-35
4021 5205 01	15-29
4021 5206 01	15-30
4021 5207 01	13-18
4021 5211 01	14-20
4021 5212 02	14-19
4021 5213 01	14-18
4021 5214 01	14-23

Parts No.	Page No.
4021 5219 01	14-25
4021 5220 01	15-31
4021 5221 01	14-29
4021 5224 02	14-44
4021 5225 01	14-9
4021 5226 01	14-15
4021 5227 01	14-22
4021 5231 01	14-12
4021 5232 01	14-13
4021 5235 03	14-32
4021 5301 02	12-11
4021 5302 01	12-22
4021 5303 01	12-15
4021 5304 01	12-2
4021 5305 02	12-26
4021 5306 02	12-30
4021 5307 02	12-29
4021 5309 01	12-21
4021 5310 01	12-16
4021 5311 01	12-28
4021 5312 01	12-27
4021 5313 04	12-1
4021 5314 01	12-9
4021 5315 01	12-6
4021 5316 02	12-23
4021 5601 06	13-26
4021 5604 02	13-1
4021 5606 01	15-21
4021 5607 03	15-34
4021 5608 01	15-35
4021 5609 01	15-33
4021 5611 01	15-32
4021 5614 02	15-24
4021 5615 01	15-25
4021 5616 01	15-27
4021 5617 01	15-23
4021 5618 01	15-11
4021 5619 01	15-15
4021 5623 01	15-2
4021 5720 02	17-20

Parts No.	Page No.	Parts No.	Page No.	Parts No.	Page No.	Parts No.	Page No.	Parts No.	Page No.
4021 5724 01	17-31	4034 1057 01	3-4	4034 2204 03	7-5	4034 3511 02	16-14	4034 5753 01	17-8
4021 5725 03	17-32	4034 1058 01	3-22	4034 2205 01	7-4	4034 3512 02	16-30	4034 5755 01	17-13
4021 5726 03	17-23	4034 1059 01	3-5	4034 2206 02	10-16	4034 3513 02	16-31	4034 5756 01	17-7
4021 5727 12	17-25	4034 1101 01	1-4	4034 2301 01	16-34	4034 3514 02	16-15	4034 5761 01	17-30
4021 5733 01	17-24	4034 1343 01	3-11	4034 2302 01	9-28	4034 3515 01	16-17	4034 5763 01	17-2
4021 5742 01	17-15	4034 1348 01	3-10	4034 2303 02	9-23	4034 3517 01	16-24	4034 5782 01	17-1
4021 5802 01	18-10	4034 1349 01	3-7	4034 2304 01	9-25	4034 3518 01	16-26	4034 5784 01	17-6
4021 5814 01	18-13	4034 1381 01	4-16	4034 2305 01	9-27	4034 3519 02	16-8	4034 5785 01	17-5
4021 5815 01	18-4	4034 1382 01	4-15	4034 2506 01	19-30	4034 3521 01	10-9	4034 5786 01	17-33
4021 5819 01	18-12	4034 1383 01	4-9	4034 2507 01	19-29	4034 3522 01	10-1	4034 5787 01	17-21
4021 5824 01	18-1	4034 1571 01	1-2	4034 2508 01	19-28	4034 3523 01	10-10	4034 5801 01	18-14
4021 6505 01	13-4	4034 2007 01	7-1	4034 2515 03	19-31	4034 3524 01	10-11	4034 5802 01	18-7
4021 6818 01	11-4	4034 2008 01	7-8	4034 2517 01	19-26	4034 3525 01	10-12	4034 5803 01	18-8
4021 6820 01	13-28	4034 2010 03	9-34	4034 2535 02	9-8	4034 3527 01	10-3	4034 5804 01	18-16
4021 6831 01	11-21	4034 2011 01	8-4	4034 2536 01	19-11	4034 3528 01	10-6	4034 5805 02	18-11
4021 6844 01	12-34	4034 2012 01	18-2	4034 2537 01	19-32	4034 3530 02	16-7	4034 5806 02	18-6
4021 7301 03	3-21	4034 2013 01	8-5	4034 2538 01	19-9	4034 3531 02	9-1	4034 5807 02	18-3
4021 7319 01	27-4	4034 2014 01	9-22	4034 2540 01	19-15	4034 3532 02	9-2	4034 5808 01	18-9
4021 7903 01	26-12	4034 2015 01	7-2	4034 2550 01	19-13	4034 3534 01	10-5	4034 5809 01	18-17
4021 7904 01	26-13	4034 2016 02	20-7	4034 3001 01	10-25	4034 3535 01	16-13	4034 6201 02	20-11
4022 2255 01	18-18	4034 2017 01	10-18	4034 3004 01	10-31	4034 3538 01	16-6	4034 6202 06	20-11
4030 2080 01	7-3	4034 2018 01	10-28	4034 3005 01	21-12	4034 3539 01	16-4	4034 6205 04	20-2
4030 3093 01	11-1	4034 2019 01	11-15	4034 3005 01	25-20	4034 3550 01	16-5	4034 6801 01	7-6
4030 5204 01	14-26	4034 2021 01	9-35	4034 3006 01	10-15	4034 5202 01	14-27	4034 6805 01	20-25
4030 7500 01	3-25	4034 2022 01	8-2	4034 3012 01	22-28	4034 5241 01	14-3	4034 6806 01	20-22
4034 0121 05	20-16	4034 2023 01	10-17	4034 3014 01	21-3	4034 5242 01	14-2	4034 6810 02	19-35
4034 0125 01	20-9	4034 2024 02	7-10	4034 3014 01	25-5	4034 5243 01	14-1	4034 6811 01	20-27
4034 0151 01	22-9	4034 2028 01	9-7	4034 3016 01	21-16	4034 5301 01	12-32	4034 6812 01	20-28
4034 0201 02	19-10	4034 2029 01	9-4	4034 3017 01	21-15	4034 5622 01	15-22	4034 6813 01	20-19
4034 0751 00	17-35	4034 2030 02	7-11	4034 3102 02	11-10	4034 5702 02	17-12	4034 6815 01	9-37
4034 0760 01	26-15	4034 2031 02	8-1	4034 3104 02	11-3	4034 5708 03	17-17	4034 6816 01	10-20
4034 0761 00	12-33	4034 2032 01	20-4	4034 3105 01	11-5	4034 5711 01	17-18	4034 6817 01	20-23
4034 0762 00	12-33	4034 2033 01	20-6	4034 3106 01	11-9	4034 5714 02	17-10	4034 6819 01	9-38
4034 1001 01	3-23	4034 2038 01	11-16	4034 3107 01	11-7	4034 5715 01	17-11	4034 6821 01	19-34
4034 1006 01	3-8	4034 2101 01	8-9	4034 3501 01	16-16	4034 5716 01	17-19	4034 6822 01	10-29
4034 1007 01	3-17	4034 2107 01	9-11	4034 3503 02	16-23	4034 5722 01	17-29	4034 6825 02	20-18
4034 1014 01	3-18	4034 2108 01	9-12	4034 3504 01	10-2	4034 5723 01	17-28	4034 6827 01	17-26
4034 1053 01	3-1	4034 2111 01	9-13	4034 3508 01	16-11	4034 5741 01	17-34	4034 6830 01	10-21
4034 1055 01	3-6	4034 2112 01	9-33	4034 3509 02	9-29	4034 5751 01	17-3	4034 6834 01	20-21
4034 1056 01	3-3	4034 2202 01	20-1	4034 3510 01	16-1	4034 5752 01	17-14	4034 6835 01	8-12

Parts No.	Page No.	Parts No.	Page No.	Parts No.	Page No.	Parts No.	Page No.	Parts No.	Page No.
4034 6836 01	9-36	4037 7406 01	3-16	4163 5293 01	9-24	4508 1001 01	5-13	4508 1055 01	6-17
4034 6837 01	20-20	4038 3063 01	22-29	4163 5293 01	12-3	4508 1003 01	4-2	4508 1056 01	6-18
4034 6840 01	16-37	4038 5601 00	22-15	4163 5293 01	13-23	4508 1005 01	4-7	4508 1057 01	6-36
4034 6847 01	20-24	4038 5655 00	22-6	4163 5293 01	14-17	4508 1009 01	5-1	4508 1058 01	6-19
4034 6860 01	4-14	4040 M600 00	20-3	4163 5293 01	16-28	4508 1010 01	6-34	4508 1059 01	6-31
4034 6880 01	9-37	4040 N300 00	27-3	4163 5293 01	18-15	4508 1011 01	6-38	4508 1060 01	6-30
4034 6881 02	20-26	4106 2063 01	7-13	4163 5293 01	21-13	4508 1012 01	6-39	4508 1062 01	6-28
4034 7306 01	16-2	4106 2063 01	8-13	4163 5293 01	25-33	4508 1013 02	6-20	4508 1063 01	6-27
4034 7309 01	3-19	4106 2063 01	9-39	4163 5296 03	14-4	4508 1015 01	6-35	4508 1064 01	6-24
4034 7310 01	16-35	4106 2063 01	10-19	4163 5298 01	14-11	4508 1016 01	6-26	4508 1065 01	6-25
4034 7330 01	21-11	4106 2063 01	19-37	4163 5603 02	15-19	4508 1016 01	6-44	4508 1066 01	6-32
4034 7331 01	11-8	4109 2003 01	25-18	4163 5604 03	15-6	4508 1017 01	5-9	4508 1067 01	6-33
4034 7332 01	11-8	4128 1978 01	8-7	4163 5605 03	15-36	4508 1018 01	5-8	4508 1068 01	6-13
4034 7333 01	16-3	4128 1979 01	8-6	4163 5606 04	15-4	4508 1019 02	5-3	4603 3205 01	11-6
4034 7338 01	3-15	4152 5620 02	7-12	4163 5607 02	15-3	4508 1019 02	5-5	4603 3218 01	11-14
4034 7339 01	3-14	4154 3804 01	9-40	4163 5609 01	15-13	4508 1020 01	5-7	4658 3035 02	22-2
4034 7340 01	3-13	4154 3804 01	19-36	4163 5611 01	15-12	4508 1021 01	5-6	4658 3040 01	22-7
4034 7341 01	3-13	4156 3826 01	23-13	4163 5612 02	13-2	4508 1023 01	5-4	4658 3046 01	22-26
4034 7402 01	17-9	4162 4074 01	15-7	4163 5614 01	15-18	4508 1024 02	4-11	4658 3144 02	24-29
4034 7403 01	17-9	4163 4072 01	15-9	4163 5617 01	15-5	4508 1025 01	4-12	4658 3516 01	19-14
4034 7404 01	17-9	4163 4103 01	13-8	4163 5620 01	15-1	4508 1026 01	5-14	4658 7305 01	27-6
4034 7507 01	27-1	4163 4104 02	13-7	4163 5625 01	15-14	4508 1027 01	5-12	4686 0121 01	23-9
4034 7603 01	27-2	4163 4116 01	13-21	4163 5639 01	15-26	4508 1028 01	5-11	4686 0210 01	24-27
4034 7901 01	26-14	4163 4361 04	15-8	4163 6051 02	14-42	4508 1029 01	5-10	4686 0211 01	25-23
4034 M200 00	11-20	4163 4370 01	15-10	4192 1464 01	16-9	4508 1031 01	6-40	4686 0902 01	10-26
4034 M200 00	19-16	4163 5101 01	14-24	4498 3328 01	24-31	4508 1032 01	4-17	4686 0902 01	24-16
4034 M600 00	7-7	4163 5102 01	12-24	4498 3333 02	24-32	4508 1035 01	5-15	4686 0903 01	23-6
4034 M601 00	9-20	4163 5102 01	14-16	4498 3345 04	25-11	4508 1037 02	2-4	4686 0903 01	24-1
4034 R700 00	17-35	4163 5219 03	14-33	4498 3388 01	10-7	4508 1038 01	5-16	4686 3304 01	7-9
4034 R701 00	17-35	4163 5221 01	14-43	4498 3404 01	25-3	4508 1042 01	6-9	4686 3304 01	11-17
4034 R703 00	9-21	4163 5226 01	14-10	4498 3826 01	25-10	4508 1044 01	6-37	4686 3304 01	23-14
4034 R704 00	8-8	4163 5229 02	14-30	4498 3833 01	25-6	4508 1045 01	6-4	4686 3306 03	23-19
4034 R706 00	16-18	4163 5230 03	14-8	4506 1002 01	4-5	4508 1046 01	6-6	4686 3307 01	24-10
4037 0104 01	10-22	4163 5231 02	14-14	4506 1004 01	4-3	4508 1047 01	6-5	4686 3308 01	24-13
4037 0104 01	23-11	4163 5237 01	14-36	4506 1005 01	4-8	4508 1048 01	6-3	4686 3310 01	24-2
4037 0906 01	10-8	4163 5244 01	14-39	4506 1021 01	6-7	4508 1049 01	6-1	4686 3312 01	24-20
4037 0906 01	10-30	4163 5245 01	14-31	4506 1029 01	6-29	4508 1050 01	6-2	4686 3313 01	24-30
4037 0906 01	11-26	4163 5260 01	14-28	4506 1034 02	6-11	4508 1051 01	6-15	4686 3314 01	24-33
4037 0906 01	17-27	4163 5271 01	14-34	4506 1036 01	6-21	4508 1053 01	6-12	4686 3316 01	24-28
4037 3210 01	22-14	4163 5272 01	14-37	4506 4008 01	6-10	4508 1054 01	6-16	4686 3317 02	23-16

Parts No.	Page No.
4686 3318 01	23-5
4686 3319 01	23-17
4686 3320 14	25-24
4686 3321 01	25-14
4686 3322 01	25-12
4686 3323 02	25-32
4686 3324 02	25-30
4686 3325 02	25-16
4686 3326 03	25-15
4686 3327 01	25-25
4686 3328 01	25-2
4686 3329 01	25-19
4686 3330 01	25-27
4686 3333 01	24-25
4686 3334 01	24-3
4686 3335 01	23-2
4686 3336 01	24-18
4686 3337 01	24-4
4686 3341 01	24-14
4686 3343 01	24-9
4686 3346 01	25-8
4686 3347 01	25-9
4686 3348 02	25-21
4686 3349 01	25-22
4686 3350 01	21-14
4686 3350 01	25-17
4686 3351 01	24-7
4686 3353 01	24-19
4686 3354 01	24-24
4686 3355 01	24-26
4686 3356 01	24-22
4686 3357 01	24-21
4686 3358 01	24-11
4686 3359 01	24-12
4686 3360 01	24-5
4686 3361 01	24-8
4686 3362 01	23-3
4686 3364 01	23-4
4686 3365 01	25-1
4686 3366 01	25-26

Parts No.	Page No.
4686 3367 01	25-28
4686 3369 01	23-7
4686 3371 01	24-23
4686 3372 01	23-1
4686 3373 01	23-15
4686 3374 01	23-18
4686 3375 01	25-7
4686 6801 02	23-20
4686 6802 04	23-21
4686 7315 01	25-4
4687 3262 01	11-13
4687 3262 01	27-5
4687 3281 01	22-20
4687 7304 01	11-12
9312 1100 13	12-5
9313 1300 31	16-36
9314 1300 11	19-1
9321 2100 22	24-15
9322 1300 11	9-14
9326 1000 51	20-14
9326 1100 11	2-5
9326 2820 11	1-8
9335 1300 61	4-10
9335 1300 61	10-13
9335 1400 61	12-8
9372 2300 41	17-22
9381 4101 31	27-3
9381 4300 31	27-3
9381 4300 41	27-3
9384 1000 51	26-1
9384 1000 51	26-1
9384 1100 91	26-4
9384 1100 91	26-4
9384 1100 91	26-4
9384 1310 81	26-17
9384 1310 91	26-2
9384 1311 11	26-11
9384 1621 21	3-9
9384 1621 21	20-10
9384 1900 54	26-5

Parts No.	Page No.
9384 1900 56	20-8
9384 1900 56	23-8
9384 1911 11	26-6
9384 1921 11	26-3
9384 1921 11	26-3
9384 2010 21	26-9
9384 2010 21	26-9
9384 2010 21	26-9
9384 2010 21	26-19
9384 2910 31	26-10
9J03 M100 00	20-12
9J06 M102 00	19-12
9J06 M900 00	26-18
A08E 1300 00	20-15
A08E 1600 00	3-20
A08E 1601 00	3-12
A08E 1900 00	2-6
A08E 1901 00	2-25
A08E 1902 00	2-6
A08E 1903 00	2-25
A08E 1904 00	2-6
A08E 1905 00	2-25
A08E 3700 00	14-45
A08E 3701 00	15-37
A08E 5600 00	22-25
A08E 5601 00	22-33
A08E 9400 00	3-26
A08E 9401 00	3-26
A08E 9402 00	3-26
A08E 9411 00	3-26
A08E 9412 00	3-26
A08E 9415 00	3-13
A08E M700 00	20-17
A08E M701 00	2-22
A08E M702 00	2-22
A08E M703 00	2-22
A08E M704 00	2-22
A08E PP00 00	4-18
A08E PP01 00	4-4
A08E PP02 00	4-1

Parts No.	Page No.
A08E PP03 00	6-43
A08E PP04 00	6-42
A08E PP05 00	5-2
A08E PP06 00	6-41
A08E PP07 00	4-13
A08E PP08 00	6-14
A08E PP09 00	6-22
A08E PP0A 00	6-23
A08E PP0B 00	6-8
A08E PP0C 00	2-24
A08E PP0D 00	2-11
A08E PP0E 00	2-10
A08E PP0F 00	2-9
A08E PP0G 00	2-8
A08E PP0H 00	2-7
A08E PP0J 00	2-12
A08E PP0K 00	2-13
A08E PP0M 00	2-17
A08E PP0N 00	2-15
A08E PP0P 00	2-16
A08E PP0R 00	2-20
A08E PP0S 00	2-18
A08E PP0T 00	2-19
A08E PP0U 00	2-14
A08E PP0V 00	2-2
A08E PP0W 00	2-1
A08E PP0X 00	2-1
A08E PP10 00	2-21
A08E PP11 00	2-23
A08E PP12 00	2-28
A08E PP13 00	2-29
A08E PP14 00	4-6
A08E PP15 00	2-26
A08E PP17 00	2-26
A08E PP18 00	2-26
A08E PP19 00	2-26
A08E PP1A 00	2-27
A08E PP1B 00	2-27
A08E R701 00	13-15
A08E R702 00	13-27

Parts No.	Page No.
A08E R703 00	17-35

ORIGINAL COVER

CHINA ONLY

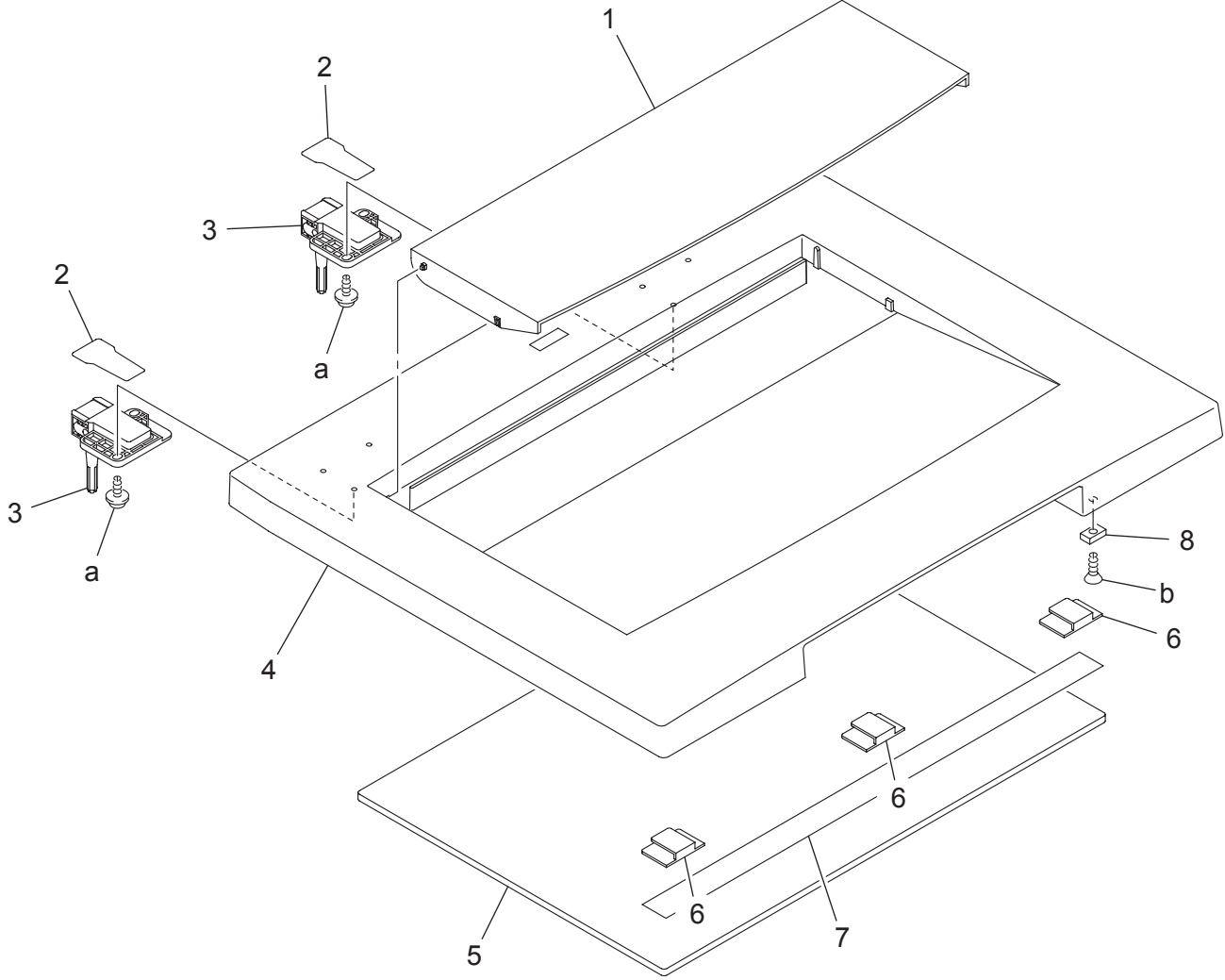

ORIGINAL COVER

Key	Part No.	Description	Destinations	Class	QTY	Standard parts
1	1171 1126 01	ORIGINAL HOLDER	J	C	1	a-9739 0412 14 b-9657 0314 07
2	4034 1571 01	COVER	J	C	2	
3	1171 1127 03	HINGE	J	C	2	
4	4034 1101 01	ORIGINAL COVER	J	C	1	
5	1139 1704 14	PAD	J	C	1	
6	1139 1703 02	SLIDER	J	C	3	
7	1139 1706 01	SEAL	J	C	1	
8	9326 2820 11	MAGNET	J	D	1	

CONTROL PANEL

改訂版 REVISED EDITION	日付 DATE
	SEPTEMBER 2007

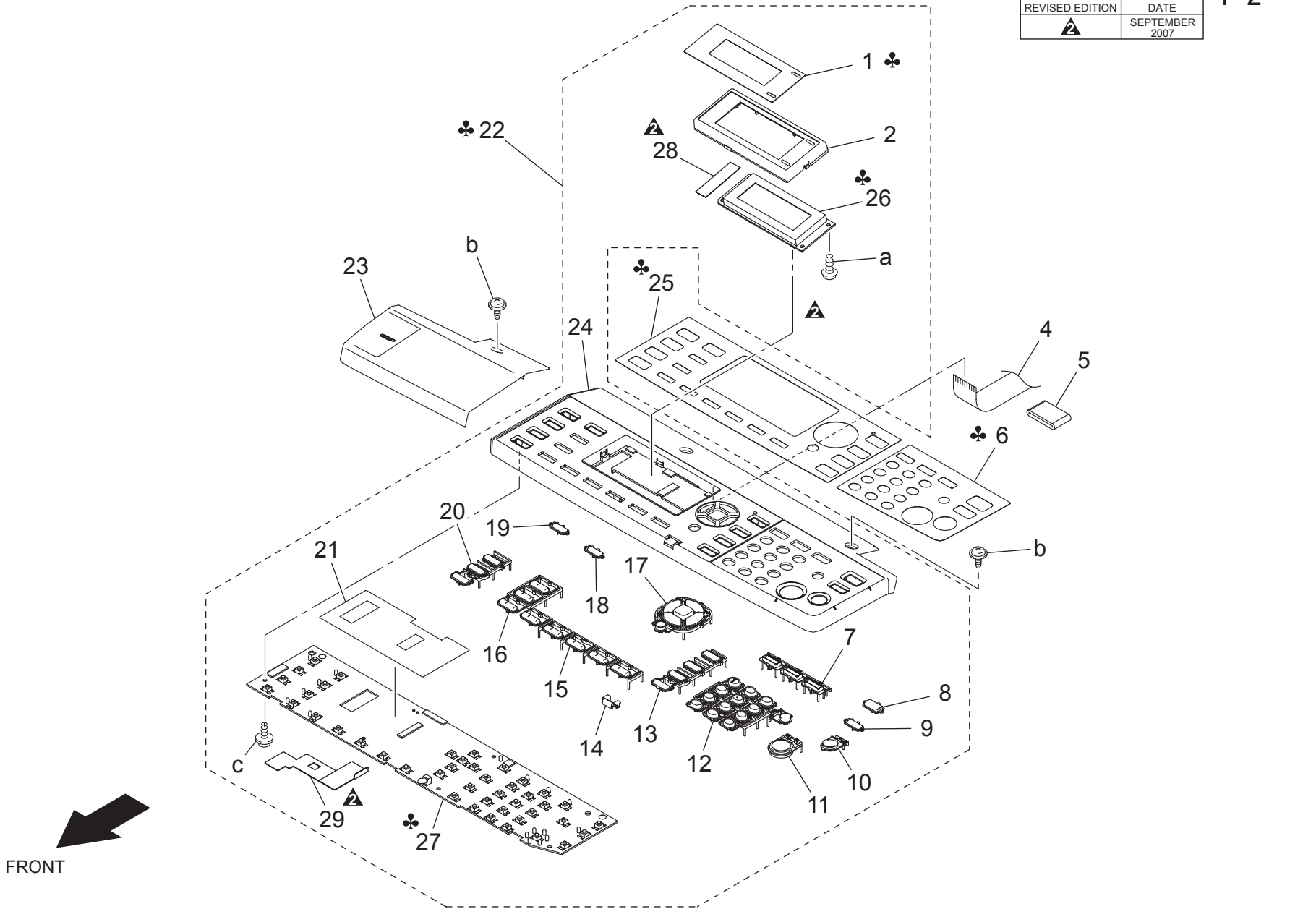

CONTROL PANEL

Key	Part No.	Description	Destinations	Class	QTY	Standard parts
1	A08E PP0W 00	Sheet	H,J	C	1	a-9742 0308 13 b-9735 0308 14 c-9739 0310 13
1	A08E PP0X 00	Sheet	B,C,D1,D3,E,F1,F2,G1,G2,I,K	C	1	
2	A08E PP0V 00	Cover		C	1	
4	4508 1037 02	WIRE HARNESS ASSY		D	1	
5	9326 1100 11	FERRITE CORE		D	1	
6	A08E 1900 00	Face Sheet-R English	B,D1,D3,E,F1,F2,G1,G2,I,K	C	1	
6	A08E 1902 00	Face Sheet-R Simple Chinese	J	C	1	
6	A08E 1904 00	Face Sheet-R Traditional Chinese	H	C	1	
7	A08E PP0H 00	Top Mode Key		C	1	
8	A08E PP0G 00	Reset Key		C	1	
9	A08E PP0F 00	Interrupt Key		C	1	
10	A08E PP0E 00	Crear/Stop Key		C	1	
11	A08E PP0D 00	Start Key		C	1	
12	A08E PP0J 00	10-Key Pad		C	1	
13	A08E PP0K 00	Copy Function-1 Key		C	1	
14	A08E PP0U 00	Lens		C	1	
15	A08E PP0N 00	Copy Function-2 Key		C	1	
16	A08E PP0P 00	Copy Function-3 Key		C	1	
17	A08E PP0M 00	OK & Selection Key		C	1	
18	A08E PP0S 00	Mixed Original Key		C	1	
19	A08E PP0T 00	Power Save Key		C	1	
20	A08E PP0R 00	Copy Function-4 Key		C	1	
21	A08E PP10 00	Sheet		C	1	
22	A08E M701 00	Control Panel Assy	B,C,D1,D3,E,F1,F2,G1,G2,I,K	I	1	
22	A08E M702 00	Control Panel Assy	C (RUSSIA)	I	1	
22	A08E M703 00	Control Panel Assy	J	I	1	
22	A08E M704 00	Control Panel Assy	H	I	1	
23	A08E PP11 00	Cover		C	1	
24	A08E PP0C 00	Control Panel		C	1	
25	A08E 1901 00	Face Sheet-M English	B,D1,D3,E,F1,F2,G1,G2,I,K	C	1	
25	A08E 1903 00	Face Sheet-M Simple Chinese	J	C	1	
25	A08E 1905 00	Face Sheet-M Traditional Chinese	H	C	1	
26	A08E PP15 00	LCD Assy	B,C,D1,D3,E,F1,F2,G1,G2,I,K	C	1	
26	A08E PP17 00	LCD Assy	J	C	1	
26	A08E PP18 00	LCD Assy	H	C	1	
26	A08E PP19 00	LCD Assy	C(Russia)	C	1	
27	A08E PP1A 00	PWB Assy	B,C,D1,D3,E,F1,F2,G1,G2,I,K	C	1	
27	A08E PP1B 00	PWB Assy	H,J	I	1	
28	A08E PP12 00	FILM		D	1	
29	A08E PP13 00	FILM		D	1	

HOUSING

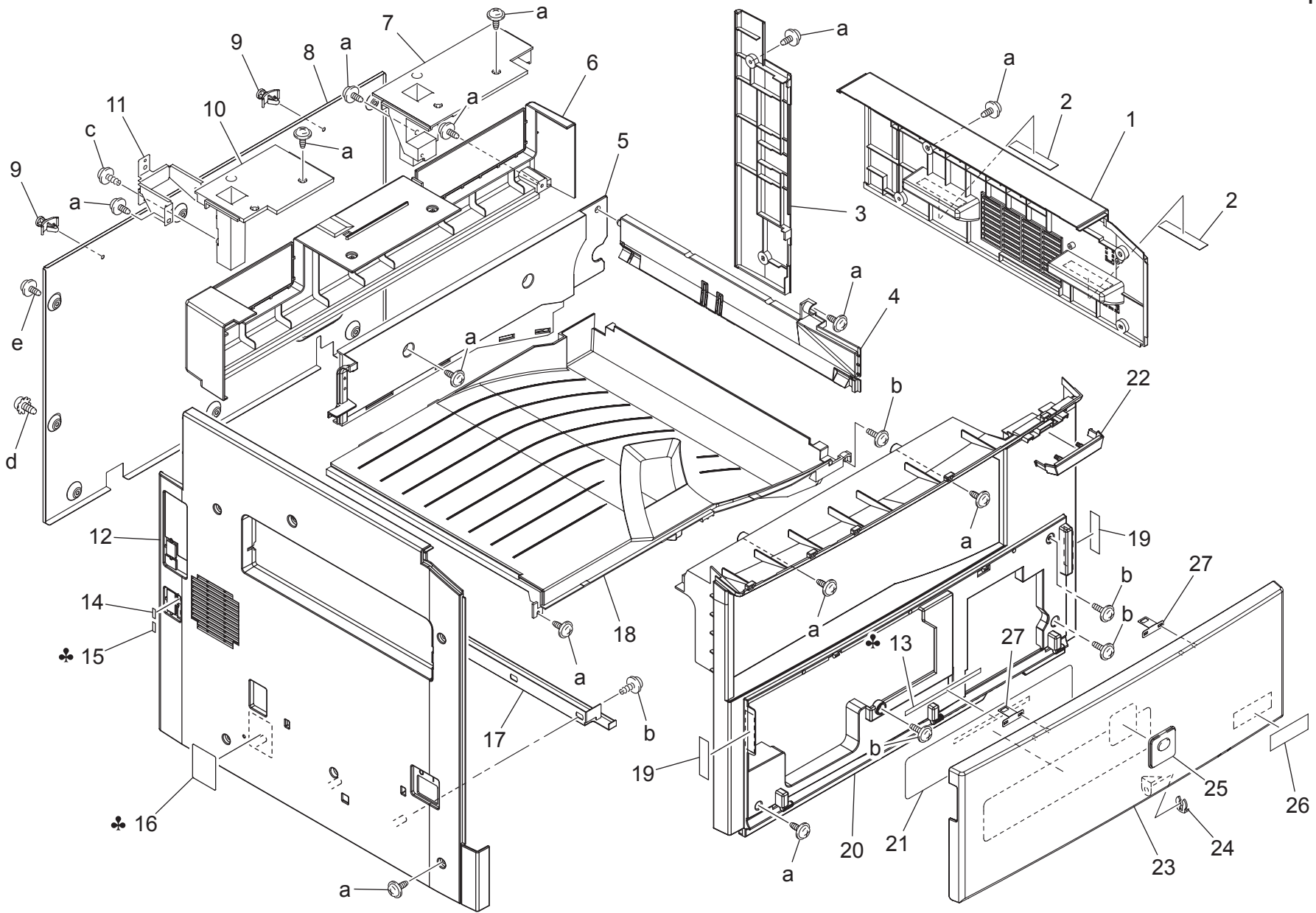

bizhub 181/bizhub 211/bizhub 220/bizhub 7621/bizhub 7622

Key	Part No.	Description	Destinations	Class	QTY	Standard parts
1	4034 1053 01	RIGHT UPPER COVER		C	1	a-9735 0308 14 b-9739 0408 14 c-9739 0308 14 d-9770 0308 14 e-9735 0306 14
2	1164 1031 01	SEAL		C	2	
3	4034 1056 01	RIGHT REAR COVER		C	1	
4	4034 1057 01	INSIDE RIGHT COVER		C	1	
5	4034 1059 01	INSIDE REAR COVER		C	1	
6	4034 1055 01	REAR COVER		C	1	
7	4034 1349 01	HOLDER		C	1	
8	4034 1006 01	REAR COVER		D	1	
9	9384 1621 21	PWB SUPPORT 6.4H		D	2	
10	4034 1348 01	HOLDER		C	1	
11	4034 1343 01	REINFORCE PLATE		D	1	
12	A08E 1601 00	LEFT COVER		C	1	
13	4034 7340 01	LABEL TONER INSTUCTION	B,D1,D3,E,F1,F2,G1,G2,H,I,K	C	1	
13	4034 7341 01	LABEL TONER INSTUCTION	C	C	1	
13	A08E 9415 00	LABEL TONER INSTUCTION	J	C	1	
14	4034 7339 01	LABEL LINE		C	1	
15	4034 7338 01	LABEL TEL	B,D1,D3,E,F1,F2,G1,G2,H,I,J ,K	C	1	
16	4037 7406 01	LABEL EARTH CAUTION	C,D1,D3,E,F2,G1,I,K	C	1	
17	4034 1007 01	GUIDE		D	1	
18	4034 1014 01	TRAY		C	1	
19	4034 7309 01	LABEL		C	2	
20	A08E 1600 00	Front Cover		C	1	
21	4021 7301 03	LABEL TONER REPLENISHMENT		C	1	
22	4034 1058 01	COVER		C	1	
23	4034 1001 01	FRONT DOOR		C	1	
24	1033 4402 01	STOPPER RING		C	1	
25	4030 7500 01	LABEL LOGO MARK		C	1	
26	A08E 9400 00	Label bizhub 211	(bizhub 211)	C	1	
26	A08E 9401 00	Label bizhub 181	(bizhub 181)	C	1	
26	A08E 9402 00	Label bizhub 220	(bizhub 220)	C	1	
26	A08E 9411 00	Label bizhub 7621	(bizhub 7621)	C	1	
26	A08E 9412 00	Label bizhub 7622	(bizhub 7622)	C	1	
27	4021 1009 01	REINFORCE PLATE		C	2	

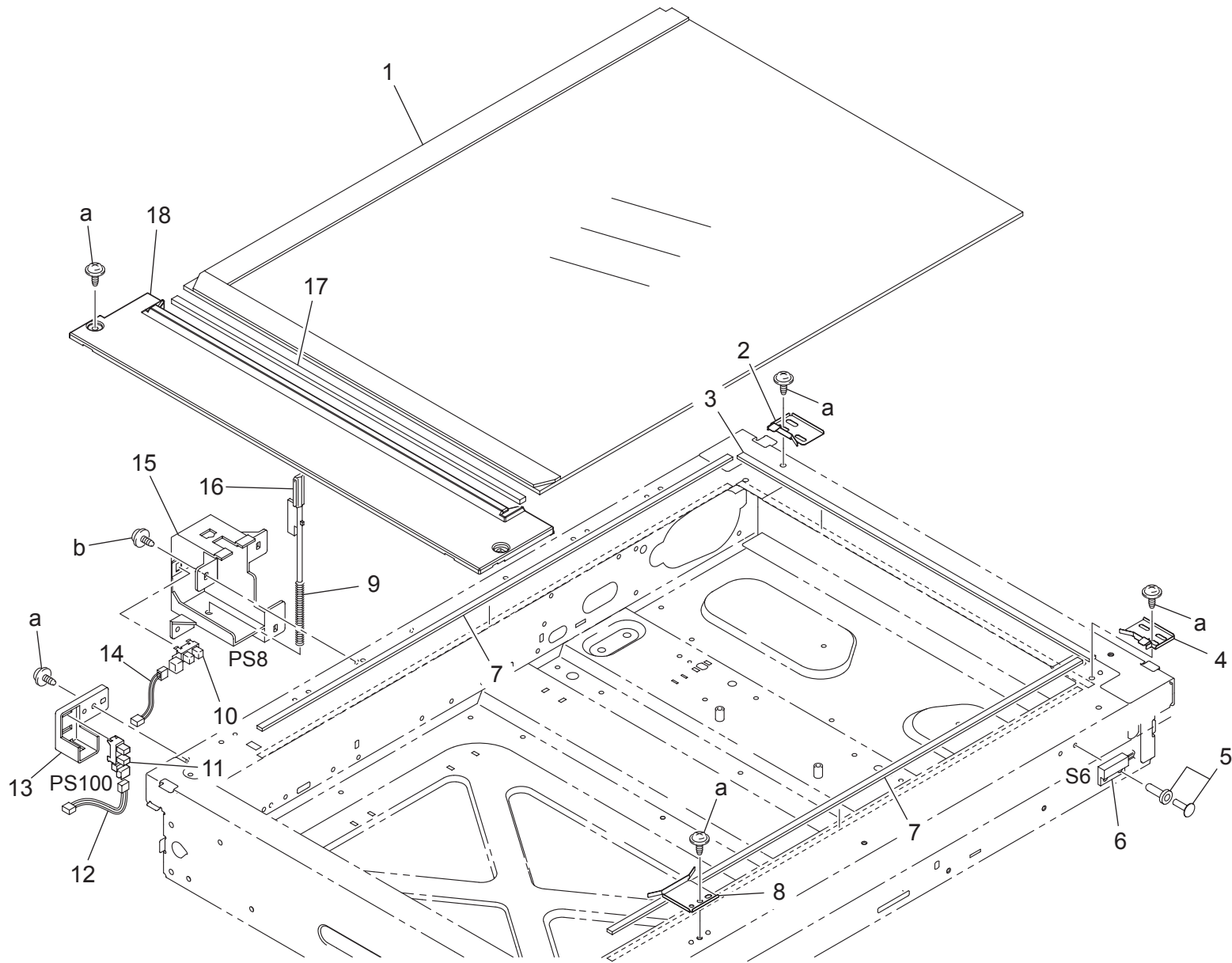

IR SECTION

Key	Part No.	Description	Destinations	Class	QTY	Standard parts
1	A08E PP02 00	Original Cover		C	1	a-9735 0306 14 b-9735 0308 14
2	4508 1003 01	PLATE SPRING		C	1	
3	4506 1004 01	CUSHION		C	1	
4	A08E PP01 00	Plate Spring		C	1	
5	4506 1002 01	PIN		D	1	
6	A08E PP14 00	Magnetic Switch		C	1	
7	4508 1005 01	SEAL		C	2	
8	4506 1005 01	SET PLATE		C	1	
9	4034 1383 01	PRESSURE SPRING		C	1	
10	9335 1300 61	PHOTO INTERRUPTER		B	1	
11	4508 1024 02	PHOTOINTERRUPTER		B	1	
12	4508 1025 01	WIRE HARNESS ASSY		D	1	
13	A08E PP07 00	Cover		C	1	
14	4034 6860 01	WIRE HARNESS ASSY		D	1	
15	4034 1382 01	HOLDER		D	1	
16	4034 1381 01	LEVER		C	1	
17	4508 1032 01	SEAL		C	1	
18	A08E PP00 00	Cover		C	1	

IR SECTION

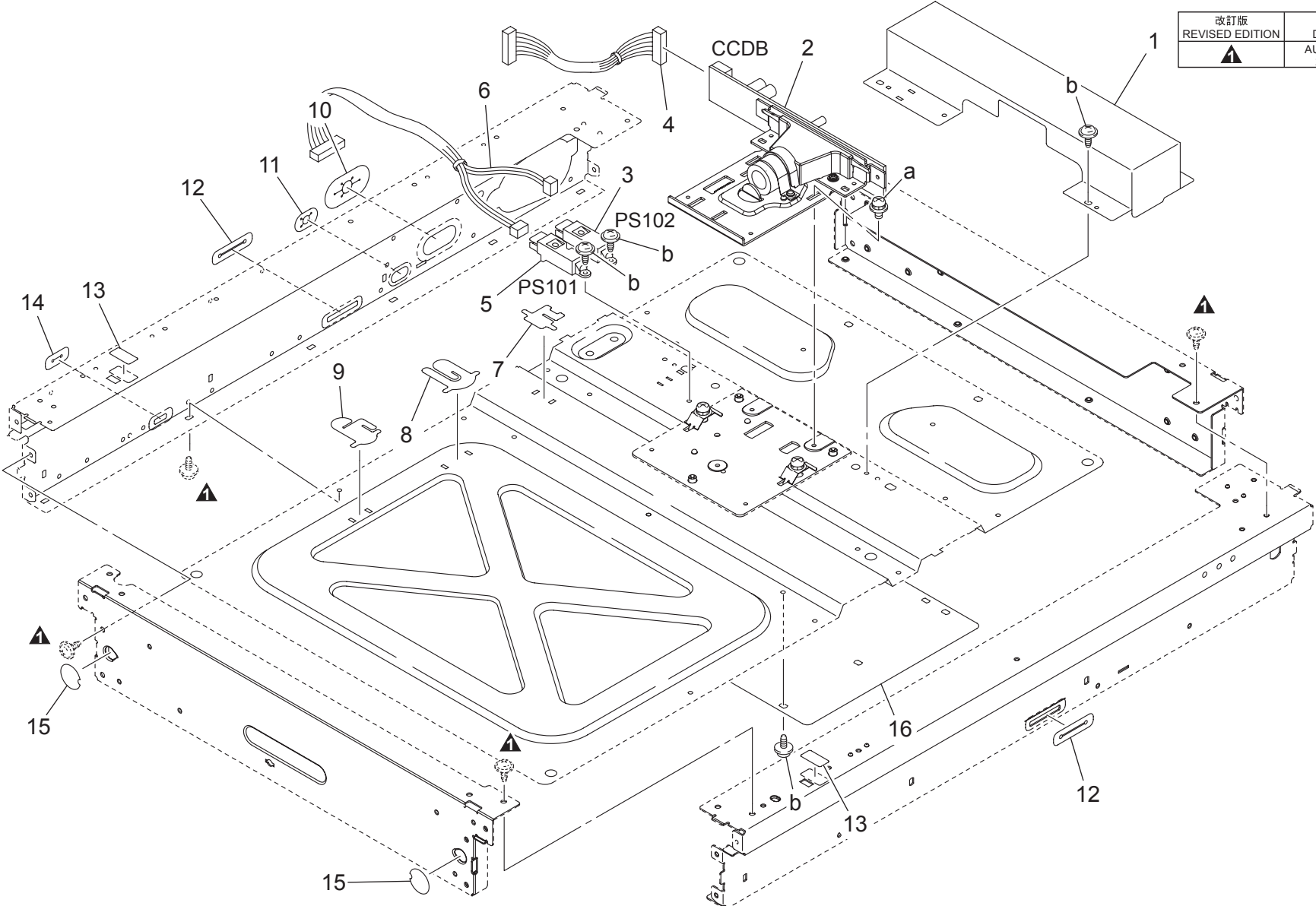

IR SECTION

Key	Part No.	Description	Destinations	Class	QTY	Standard parts
1	4508 1009 01	COVER		D	1	a-9646 0306 14 b-9735 0306 14
2	A08E PP05 00	Lens Assy		I	1	
3	4508 1019 02	PHOTOINTRUPTTER	(Option)	C	1	
4	4508 1023 01	WIRE HARNESS ASSY		D	1	
5	4508 1019 02	PHOTOINTRUPTTER		C	1	
6	4508 1021 01	WIRE HARNESS ASSY		D	1	
7	4508 1020 01	SEAL		C	1	
8	4508 1018 01	SEAL		C	1	
9	4508 1017 01	SEAL		C	1	
10	4508 1029 01	SEAL		C	1	
11	4508 1028 01	SEAL		C	1	
12	4508 1027 01	SEAL		C	2	
13	4508 1001 01	SEAL		C	2	
14	4508 1026 01	SEAL		C	1	
15	4508 1035 01	SEAL		C	2	
16	4508 1038 01	SET PLATE		D	1	

SLIDER SECTION

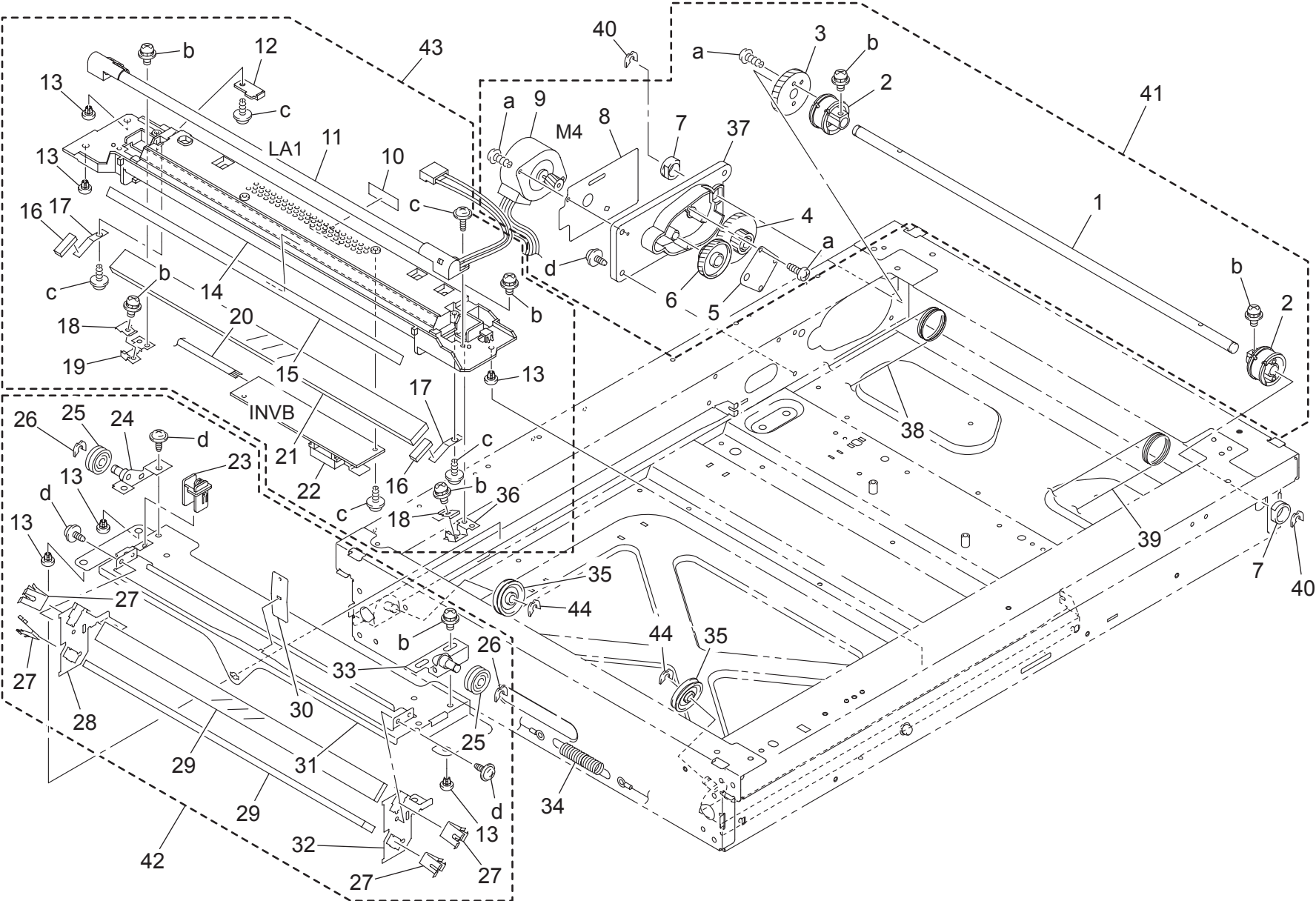

SLIDER SECTION

Key	Part No.	Description	Destinations	Class	QTY	Standard parts
1	4508 1049 01	SHAFT		D	1	a-9732 0308 14 b-9646 0308 14 c-9739 0308 14 d-9735 0306 14
2	4508 1050 01	PULLEY		C	2	
3	4508 1048 01	GEAR		C	1	
4	4508 1045 01	GEAR		C	1	
5	4508 1047 01	WASHER		D	1	
6	4508 1046 01	GEAR		C	1	
7	4506 1021 01	BUSHING		C	2	
8	A08E PP0B 00	Bracket		D	1	
9	4508 1042 01	MOTOR		B	1	
10	4506 4008 01	LABEL		D	1	
11	4506 1034 02	LAMP		B	1	
12	4508 1053 01	STOPPER		D	1	
13	4508 1068 01	SLIDER		D	6	
14	A08E PP08 00	Frame		D	1	
15	4508 1051 01	REFLECTOR		C	1	
16	4508 1054 01	SEAL		C	2	
17	4508 1055 01	HOLDER		D	2	
18	4508 1056 01	SET PLATE		D	2	
19	4508 1058 01	BRACKET		D	1	
20	4508 1013 02	WIRE HARNESS ASSY		D	1	
21	4506 1036 01	MIRROR		C	1	
22	A08E PP09 00	Inverter		C	1	
23	A08E PP0A 00	Guide		D	1	
24	4508 1064 01	BRACKET		D	1	
25	4508 1065 01	PULLEY		C	2	
26	4508 1016 01	WASHER		C	2	
27	4508 1063 01	PLATE SPRING		D	4	
28	4508 1062 01	BRACKET		D	1	
29	4506 1029 01	MIRROR		C	2	
30	4508 1060 01	PLATE SPRING		D	1	
31	4508 1059 01	FRAME		D	1	
32	4508 1066 01	BRACKET		D	1	
33	4508 1067 01	BRACKET		D	1	
34	4508 1010 01	TENSION SPRING		C	1	
35	4508 1015 01	PULLEY		C	2	
36	4508 1057 01	BRACKET		D	1	
37	4508 1044 01	HOLDER		D	1	
38	4508 1011 01	WIRE		C	1	
39	4508 1012 01	WIRE		C	1	
40	4508 1031 01	WASHER		C	2	
41	A08E PP06 00	Driving Assy		C	1	
42	A08E PP04 00	2nd Slide Assy		S	1	
43	A08E PP03 00	Lamp Assy		S	1	
44	4508 1016 01	WASHER		C	2	

FRAMES

改訂版 REVISED EDITION	日付 DATE
▲	AUGUST 2007

P 7

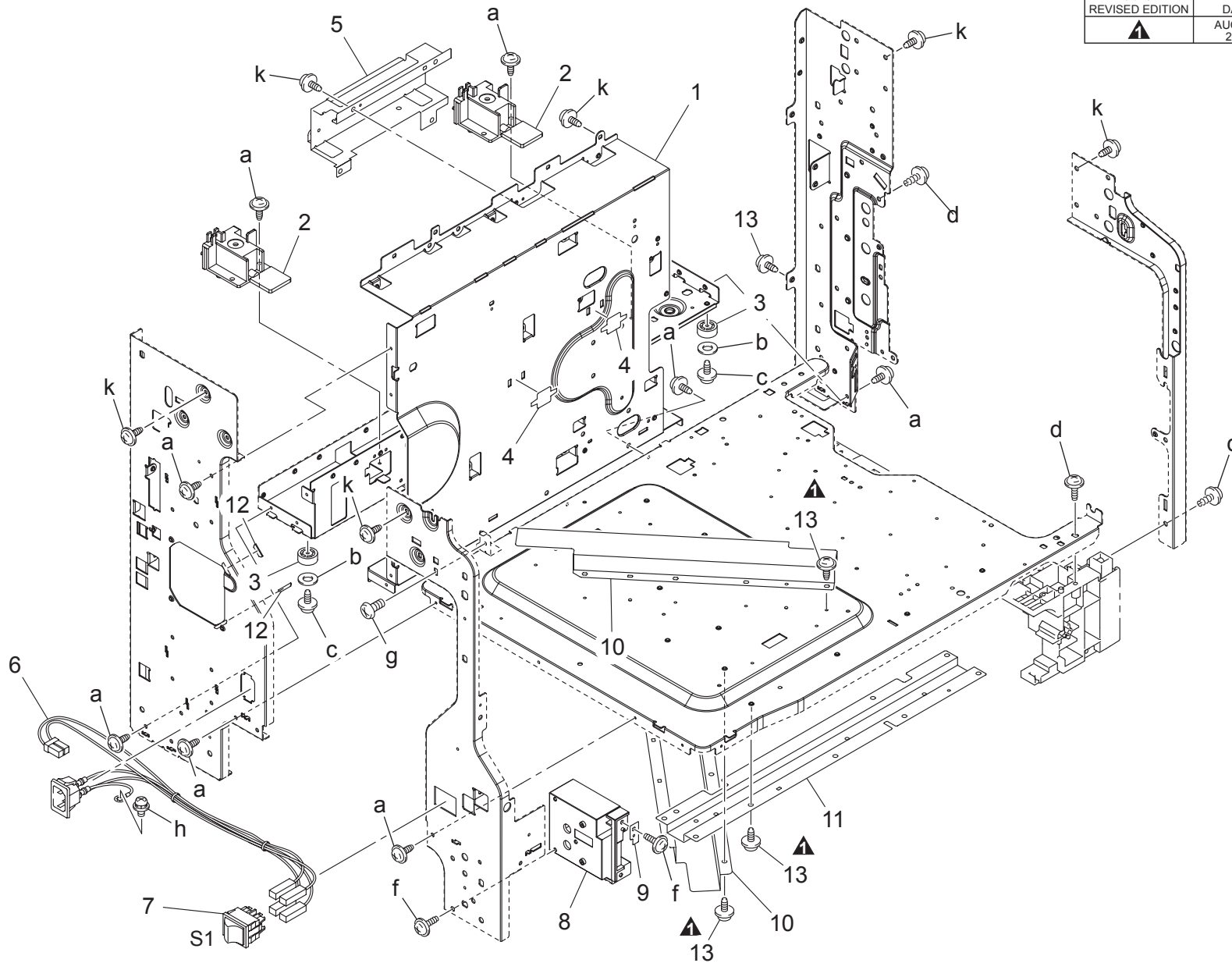

bizhub 181/bizhub 211/bizhub 220/bizhub 7621/bizhub 7622

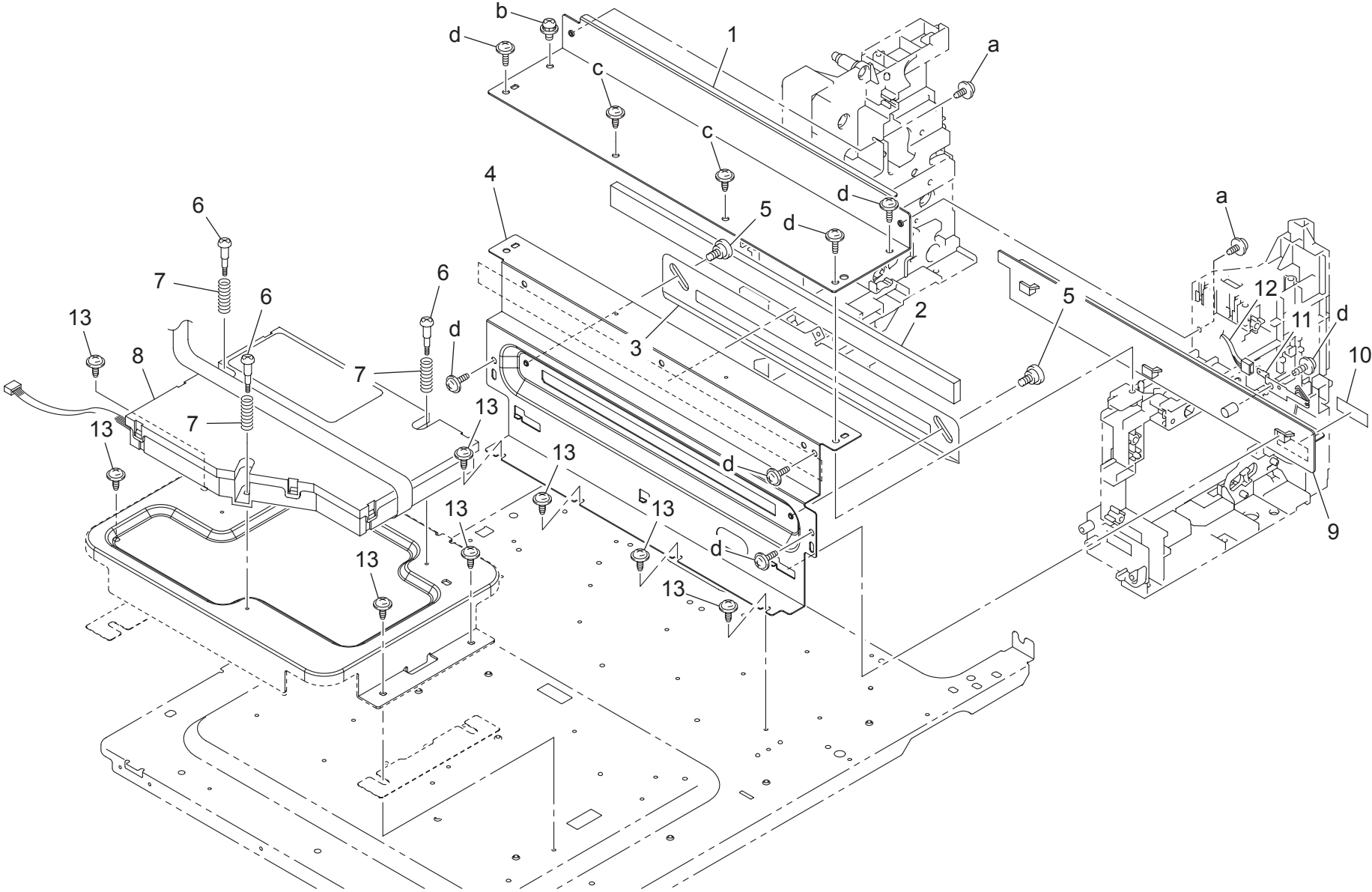

FRAMES

Key	Part No.	Description	Destinations	Class	QTY	Standard parts
1	4034 2031 02	BRACKET		D	1	a-9735 0308 14 b-9646 0310 14 c-9735 0306 14 d-9739 0408 14
2	4034 2022 01	SEAL		C	1	
3	4021 2014 12	SHUTTER		D	1	
4	4034 2011 01	BRACKET		D	1	
5	4034 2013 01	SHOULDER SCREW		C	2	
6	4128 1979 01	SHOULDER SCREW		C	3	
7	4128 1978 01	PRESSURE SPRING		C	3	
8	4034 R704 00	P/H ASSY		I	1	
9	4034 2101 01	HOLDER		D	1	
10	1129 7303 01	LABEL HI-VOL CAUTION		D	1	
11	4021 2110 01	CONTACT		C	1	
12	4034 6835 01	WIRE HARNESS ASSY		D	1	
13	4106 2063 01	SCREW		C	8	

PAPER TAKE-UP SECTION

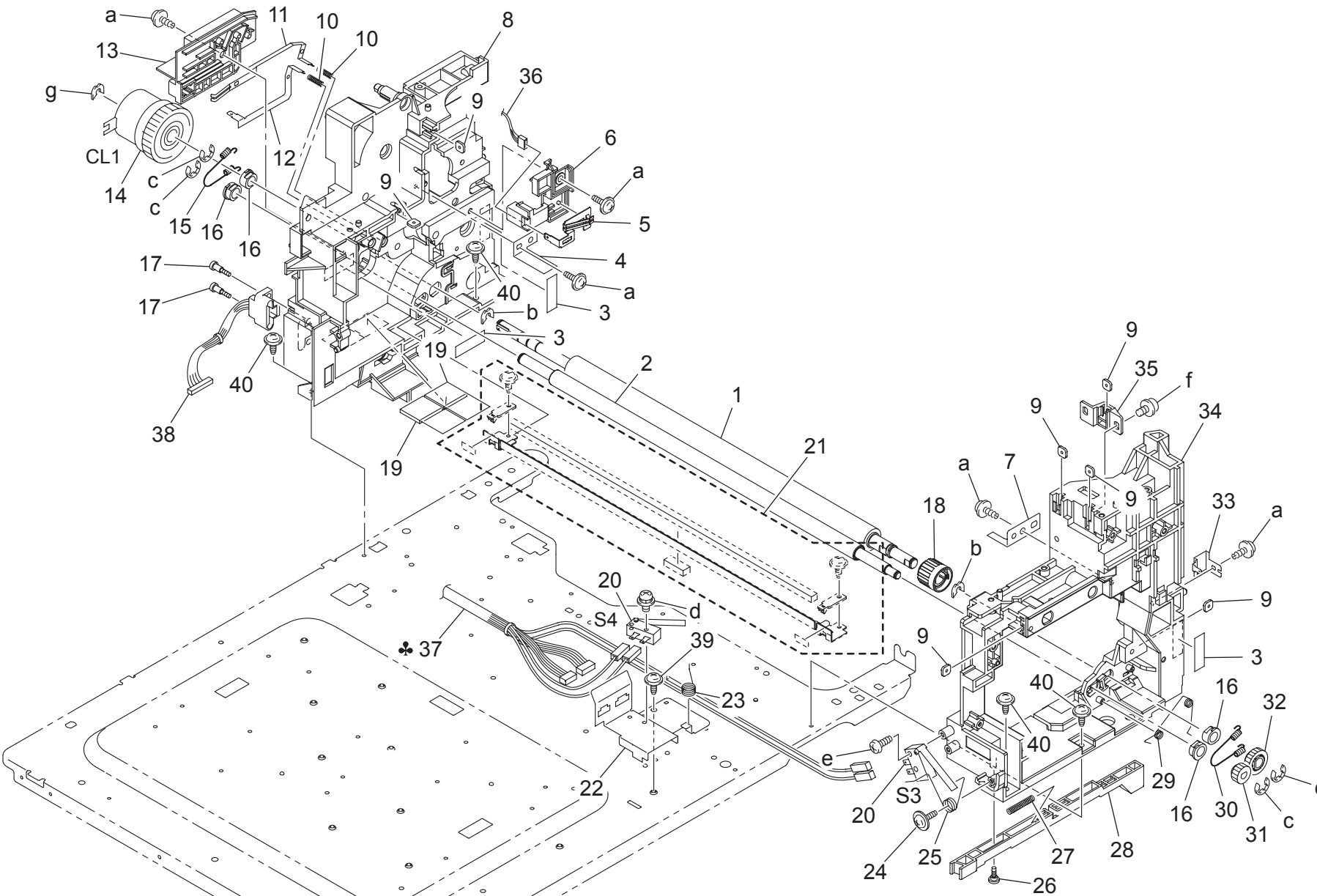

PAPER TAKE-UP SECTION

Key	Part No.	Description	Destinations	Class	QTY	Standard parts
1	4034 3531 02	ROLLER		C	1	a-9739 0408 14 b-1066 1151 01 c-9721 0500 01 d-9646 0316 14 e-9742 0318 14 f-9646 0310 14 g-9721 0500 01
2	4034 3532 02	ROLLER		C	1	
3	1129 7303 01	LABEL HI-VOL CAUTION		D	3	
4	4034 2029 01	POSITIONING PLATE		D	1	
5	4021 2106 01	CONTACT		C	1	
6	4021 2103 02	HOLDER		D	1	
7	4034 2028 01	BRACKET		D	1	
8	4034 2535 02	FRAME		D	1	
9	4002 5042 02	PLATE NUT		D	7	
10	4021 2101 01	PRESSURE SPRING		C	2	
11	4034 2107 01	CONTACT		C	1	
12	4034 2108 01	CONTACT		C	1	
13	4034 2111 01	COVER		C	1	
14	9322 1300 11	CLUTCH		C	1	
15	4021 3513 12	TENSION SPRING		C	1	
16	1164 3509 01	BUSHING		C	4	
17	4021 2018 01	SHOULDER SCREW		C	2	
18	4021 3505 01	KNOB		C	1	
19	4021 2031 01	CUSHION		C	2	
20	4034 M601 00	Micro switch		C	2	
21	4034 R703 00	CLEANING PAD		A	1	
22	4034 2014 01	BRACKET		D	1	
23	4034 2303 02	TORSION SPRING		D	1	
24	4163 5293 01	SCREW		C	1	
25	4034 2304 01	TORSION SPRING		C	1	
26	4021 2316 01	SHOULDER SCREW		C	1	
27	4034 2305 01	PRESSURE SPRING		C	1	
28	4034 2302 01	ARM		D	1	
29	4034 3509 02	CONTACT		C	1	
30	4021 3512 12	TENSION SPRING		C	1	
31	1164 3515 01	GEAR 13T		B	1	
32	1164 3508 01	GEAR 18T		B	1	
33	4034 2112 01	CONTACT		C	1	
34	4034 2010 03	RAIL		D	1	
35	4034 2021 01	BRACKET		D	1	
36	4034 6836 01	WIRE HARNESS ASSY		D	1	
37	4034 6815 01	WIRE HARNESS ASSY	B,H,F1,G2	D	1	
37	4034 6880 01	WIRE HARNESS ASSY	C,D1,D3,E,F2,G1,I,K,J	D	1	
38	4034 6819 01	WIRE HARNESS ASSY		D	1	
39	4106 2063 01	SCREW		C	1	
40	4154 3804 01	SCREW		C	4	

PAPER TAKE-UP SECTION

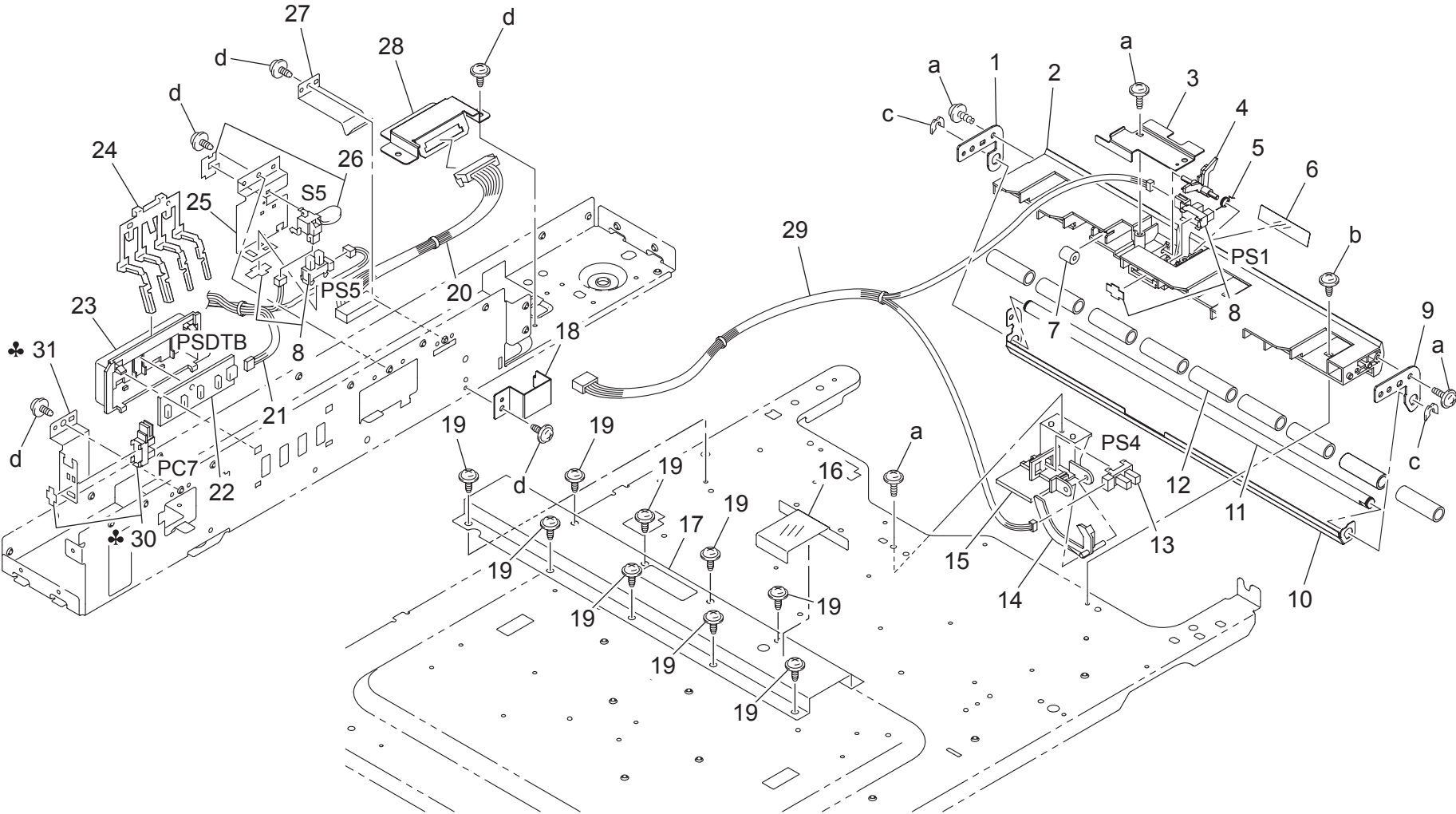

PAPER TAKE-UP SECTION

Key	Part No.	Description	Destinations	Class	QTY	Standard parts
1	4034 3522 01	BRACKET		D	1	a-9739 0308 14 b-9735 0308 14 c-1066 1151 01 d-V137 0306 03
2	4034 3504 01	HOLDER		D	1	
3	4034 3527 01	COVER		D	1	
4	4021 3504 01	ACTUATOR		C	1	
5	4034 3534 01	TORSION SPRING		C	1	
6	4034 3528 01	GUIDE		D	1	
7	4498 3388 01	COLLAR		C	1	
8	4037 0906 01	PHOTO INTERRUPTER		B	2	
9	4034 3521 01	BRACKET		D	1	
10	4034 3523 01	GUIDE PLATE		D	1	
11	4034 3524 01	SHAFT		D	1	
12	4034 3525 01	ROLLER		C	9	
13	9335 1300 61	PHOTO INTERRUPTER		B	1	
14	1164 3027 01	ACTUATOR		C	1	
15	4034 3006 01	HOLDER		D	1	
16	4034 2206 02	INSULATING MEMBER		D	1	
17	4034 2023 01	REINFORCE PLATE		D	1	
18	4034 2017 01	GUIDE		D	1	
19	4106 2063 01	SCREW		C	9	
20	4034 6816 01	WIRE HARNESS ASSY		D	1	
21	4034 6830 01	WIRE HARNESS ASSY		D	1	
22	4037 0104 01	PWB ASSY		C	1	
23	4011 3012 01	HOLDER		D	1	
24	1164 3020 03	LEVER		C	1	
25	4034 3001 01	BRACKET		D	1	
26	4686 0902 01	PUSHBUTTON SWITCH		C	1	
27	1164 3054 01	PLATE SPRING		C	1	
28	4034 2018 01	BRACKET		D	1	
29	4034 6822 01	WIRE HARNESS ASSY		D	1	
30	4037 0906 01	PHOTO INTERRUPTER	D1,D3,E,F1,F2,G1,G2,I,K	B	1	
31	4034 3004 01	BRACKET	D1,D3,E,F1,F2,G1,G2,I,K	D	1	

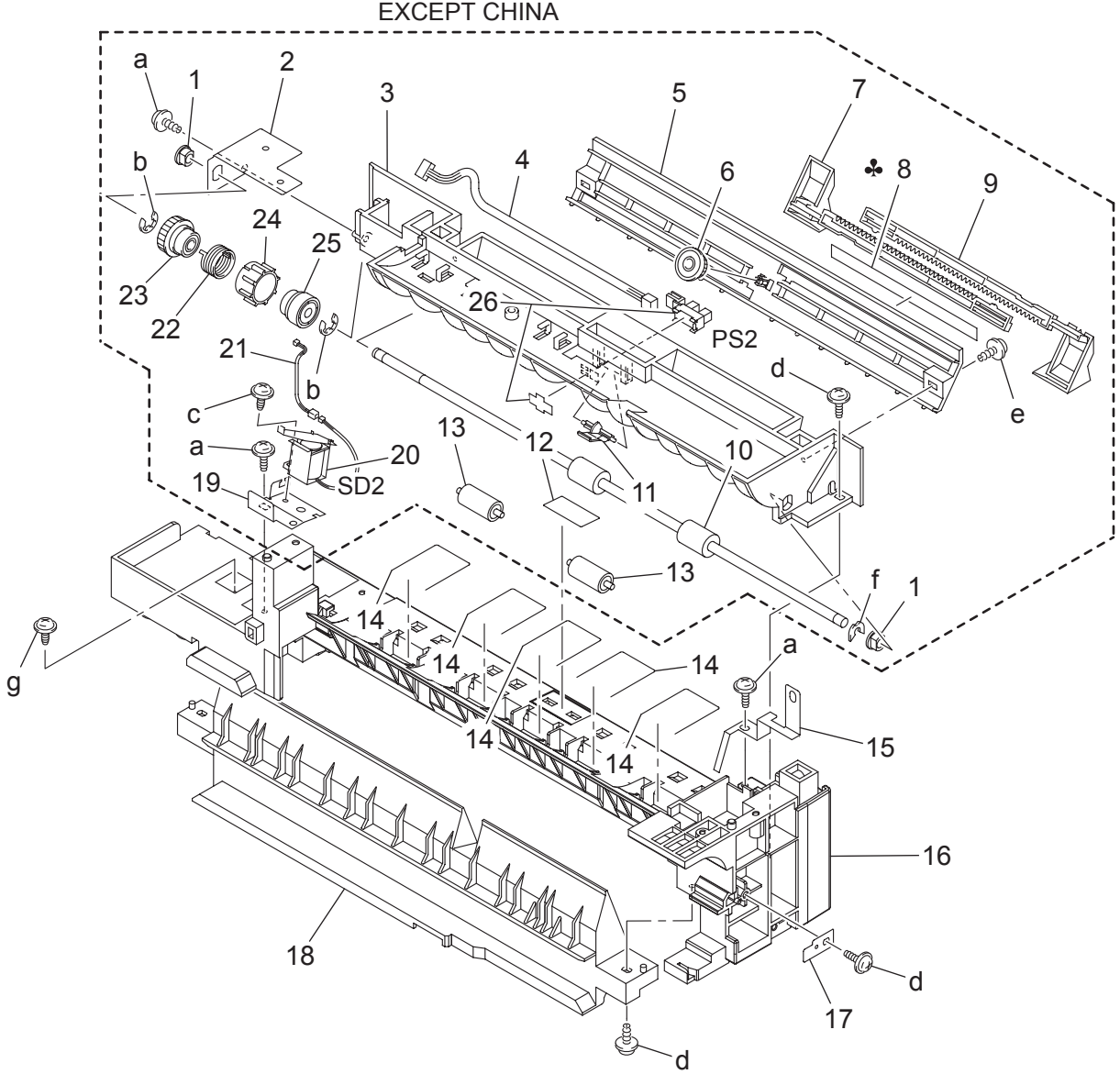

MANUAL FEED SECTION

Key	Part No.	Description	Destinations	Class	QTY	Standard parts
1	4030 3093 01	BUSHING	B,C,D1,D3,E,F1,F2,G1,G2,H,I ,K	C	2	a-9735 0306 14 b-9721 0400 01 c-V137 0306 03 d-9739 0410 14 e-9739 0308 14 f-4425 3001 01 g-9735 0308 14
2	4021 3104 01	BRACKET	B,C,D1,D3,E,F1,F2,G1,G2,H,I ,K	D	1	
3	4034 3104 02	RIGHT LOWER COVER	B,C,D1,D3,E,F1,F2,G1,G2,H,I ,K	C	1	
4	4021 6818 01	WIRE HARNESS ASSY	B,C,D1,D3,E,F1,F2,G1,G2,H,I ,K	D	1	
5	4034 3105 01	GUIDE	B,C,D1,D3,E,F1,F2,G1,G2,H,I ,K	C	1	
6	4603 3205 01	GEAR 12T	B,C,D1,D3,E,F1,F2,G1,G2,H,I ,K	C	1	
7	4034 3107 01	REGULATING PLATE	B,C,D1,D3,E,F1,F2,G1,G2,H,I ,K	C	1	
8	4034 7331 01	LABEL SCALE METRIC	C,D1,D3,E,F1,F2,G1,G2,H,I,K	C	1	
8	4034 7332 01	LABEL SCALE INCH	B,G2	C	1	
9	4034 3106 01	REGULATING PLATE	B,C,D1,D3,E,F1,F2,G1,G2,H,I ,K	C	1	
10	4034 3102 02	ROLLER	B,C,D1,D3,E,F1,F2,G1,G2,H,I ,K	A	1	
11	4011 3205 01	ACTUATOR	B,C,D1,D3,E,F1,F2,G1,G2,H,I ,K	C	1	
12	4687 7304 01	LABEL PAPER	B,C,D1,D3,E,F1,F2,G1,G2,H,I ,K	D	1	
13	4687 3262 01	ROLL	B,C,D1,D3,E,F1,F2,G1,G2,H,I ,K	C	2	
14	4603 3218 01	SPRING		C	5	
15	4034 2019 01	PLATE SPRING		D	1	
16	4034 2038 01	GUIDE		D	1	
17	4686 3304 01	STOPPER		D	1	
18	4021 2025 01	RAIL		D	1	
19	4021 3107 01	BRACKET	B,C,D1,D3,E,F1,F2,G1,G2,H,I ,K	D	1	
20	4034 M200 00	SOLENOID	B,C,D1,D3,E,F1,F2,G1,G2,H,I ,K	C	1	
21	4021 6831 01	WIRE HARNESS ASSY	B,C,D1,D3,E,F1,F2,G1,G2,H,I ,K	D	1	
22	4021 3108 01	SPRING	B,C,D1,D3,E,F1,F2,G1,G2,H,I ,K	C	1	
23	4021 3103 01	GEAR 29T	B,C,D1,D3,E,F1,F2,G1,G2,H,I ,K	C	1	
24	4021 3106 01	RATCHET	B,C,D1,D3,E,F1,F2,G1,G2,H,I ,K	C	1	
25	4021 3105 01	COLLAR	B,C,D1,D3,E,F1,F2,G1,G2,H,I ,K	C	1	
26	4037 0906 01	PHOTO INTERRUPTER	B,C,D1,D3,E,F1,F2,G1,G2,H,I ,K	B	1	

HOPPER SECTION

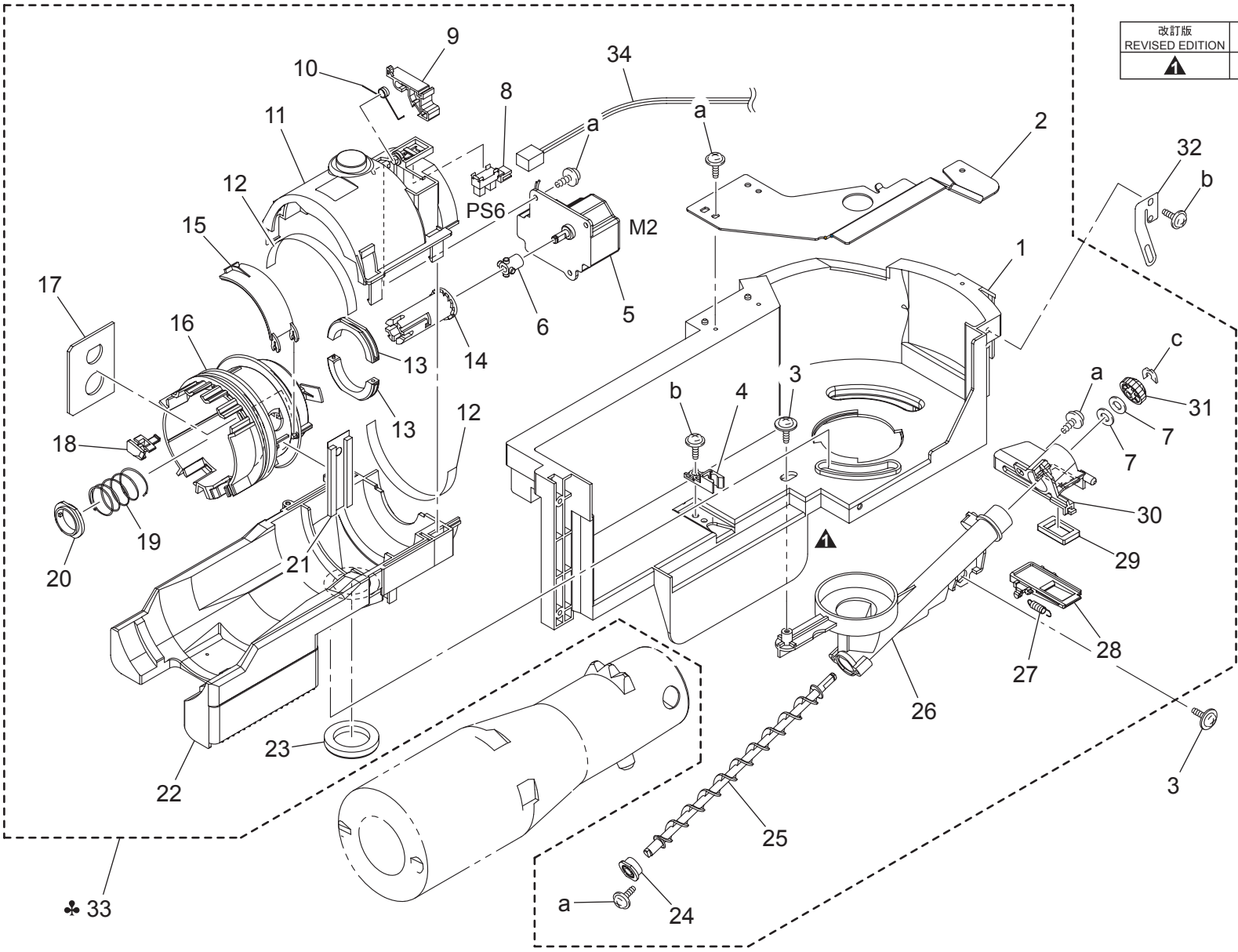

HOPPER SECTION

Key	Part No.	Description	Destinations	Class	QTY	Standard parts
1	4021 5313 04	HOLDER		D	1	a-9739 0308 14 b-9739 0410 14 c-4425 3002 01
2	4021 5304 01	BRACKET		D	1	
3	4163 5293 01	SCREW		C	2	
4	1139 5015 01	LOCK LEVER		C	1	
5	9312 1100 13	MOTOR		B	1	
6	4021 5315 01	PIN		C	1	
7	1200 1346 12	WASHER		D	2	
8	9335 1400 61	SOLID STATE SWITCH		B	1	
9	4021 5314 01	LEVER		C	1	
10	1139 5022 01	TORSION SPRING		C	1	
11	4021 5301 02	HOLDER		D	1	
12	1139 5026 01	POLYESTER FILM		C	2	
13	1151 5023 01	SUPPORT		C	2	
14	1165 5326 02	SHAFT		D	1	
15	4021 5303 01	SHUTTER		D	1	
16	4021 5310 01	COUPLING		C	1	
17	1174 5010 01	SHEEL		C	1	
18	1139 5018 04	DETECTING PLATE		D	3	
19	1151 5033 02	PRESSURE SPRING		C	1	
20	1151 5032 01	COLLAR		C	1	
21	4021 5309 01	SEAL		C	1	
22	4021 5302 01	HOLDER		D	1	
23	4021 5316 02	SEAL		C	1	
24	4163 5102 01	BUSHING		C	1	
25	4021 0162 02	SCREW ASSY		D	1	
26	4021 5305 02	TRANSPORT PIPE		D	1	
27	4021 5312 01	SPRING		C	1	
28	4021 5311 01	SHUTTER		D	1	
29	4021 5307 02	SEAL		C	1	
30	4021 5306 02	DUCT		D	1	
31	1139 5730 01	GEAR 18T		C	1	
32	4034 5301 01	SPRING		C	1	
33	4034 0761 00	HOPPER UNIT	C	I	1	
33	4034 0762 00	HOPPER UNIT	B,D1,D3,E,F1,F2,G1,G2,H,I,J ,K	D	1	
34	4021 6844 01	WIRE HARNESS ASSY		D	1	

CHARGE SECTION

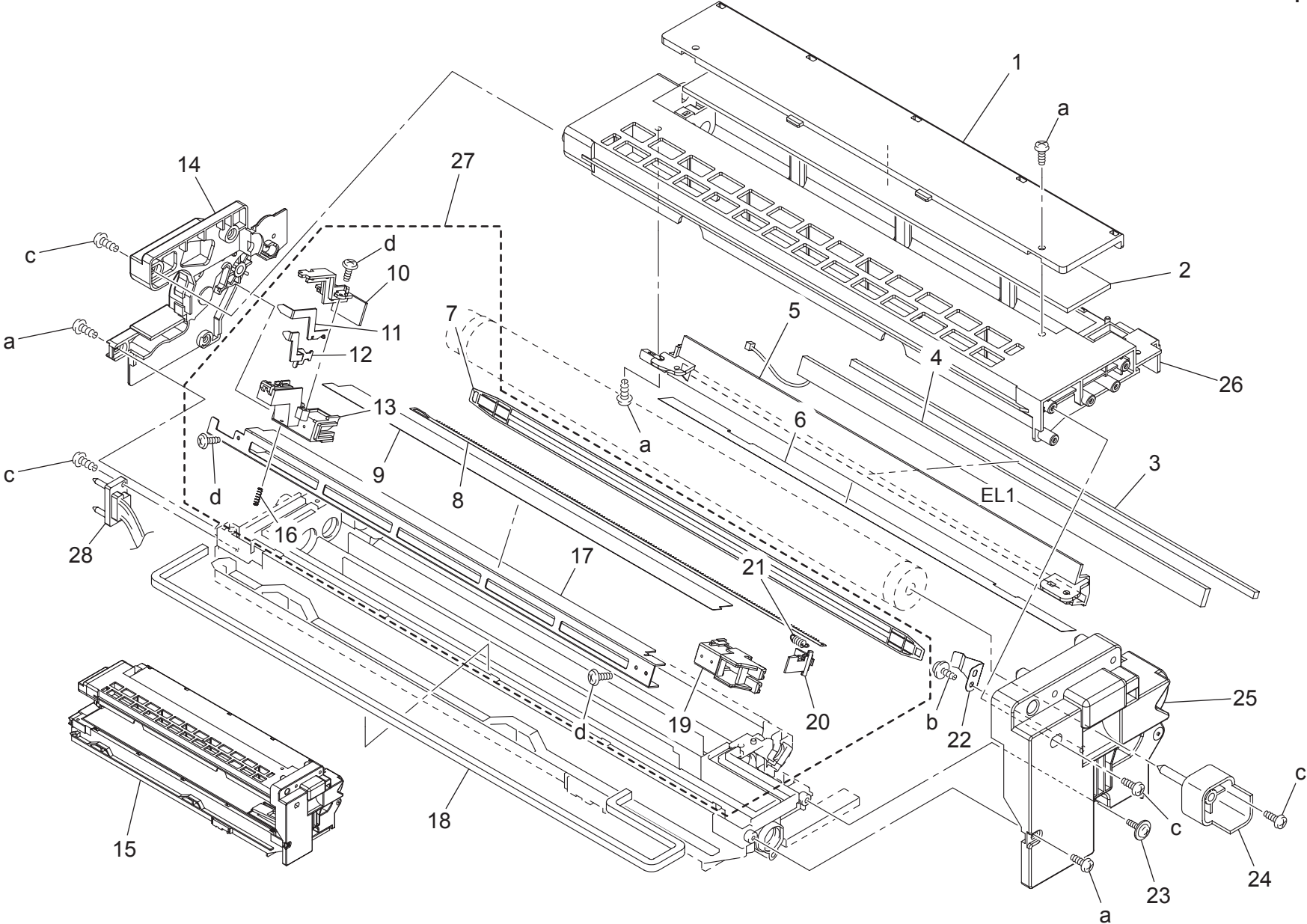

CHARGE SECTION

Key	Part No.	Description	Destinations	Class	QTY	Standard parts
1	4021 5604 02	LID		D	1	a-9742 0308 07 b-9739 0308 07 c-9742 0310 07 d-9747 1740 07
2	4163 5612 02	SEAL		C	1	
3	1165 4307 01	SEAL		C	1	
4	4021 6505 01	LED PILOT LAMP		B	1	
5	4021 4302 02	HOLDER		D	1	
6	1165 4310 01	SEAL		C	1	
7	4163 4104 02	GRID		B	1	
8	4163 4103 01	ELECTRODE NEEDLE		B	1	
9	4021 4109 01	SHIELD PLATE		C	1	
10	4021 4103 02	COVER		C	1	
11	4021 4105 01	TERMINAL		C	1	
12	4021 4106 01	TERMINAL		C	1	
13	4021 4102 02	HOLDER		D	1	
14	4021 4352 06	BRACKET		D	1	
15	A08E R701 00	IU Assy		A	1	
16	4021 4108 01	SPRING		C	1	
17	4021 4104 02	PLATE		D	1	
18	4021 5207 01	SEAL		C	1	
19	4021 4101 02	HOLDER		D	1	
20	4021 4107 01	LEVER		C	1	
21	4163 4116 01	TENSION SPRING		C	1	
22	4021 4367 01	PLATE SPRING		D	1	
23	4163 5293 01	SCREW		C	1	
24	4021 4362 01	PIN		C	1	
25	4021 4351 06	BRACKET		D	1	
26	4021 5601 06	HOUSING		D	1	
27	A08E R702 00	DRUM CHARGE UNIT		A	1	
28	4021 6820 01	WIRE HARNESS ASSY		D	1	

DEVELOPING SECTION

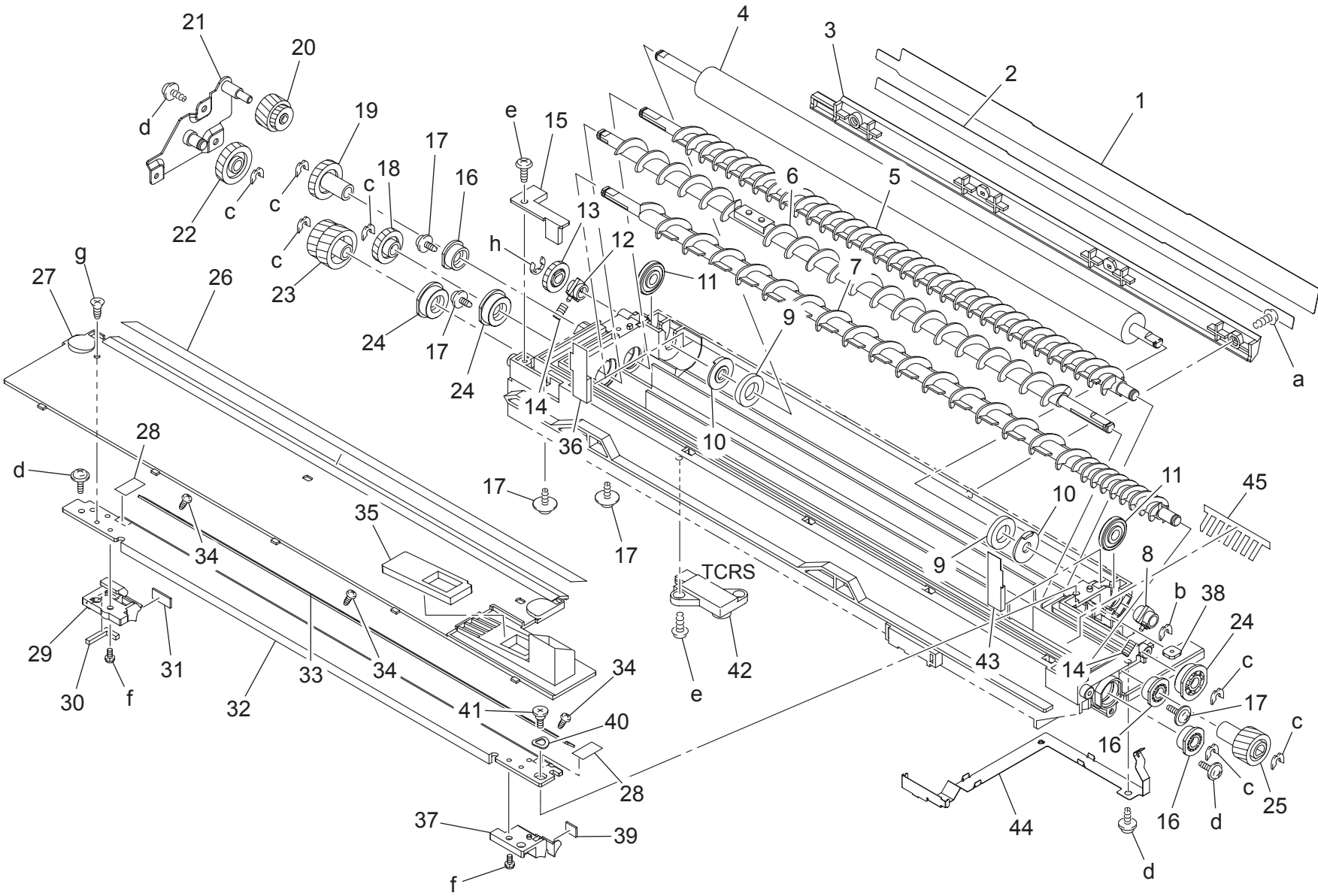

Key	Part No.	Description	Destinations	Class	QTY	Standard parts
1	4034 5243 01	GUIDE		D	1	a-9747 1750 07 b-4425 3002 01 c-4425 3001 01 d-9739 0308 07 e-9742 0308 07 f-9644 0304 21 g-9648 0306 14 h-9721 0400 01
2	4034 5242 01	GUIDE		D	1	
3	4034 5241 01	GUIDE		D	1	
4	4163 5296 03	DEVELOPING ROLLER		B	1	
5	4021 0163 05	SCREW ASSY		C	1	
6	4021 0752 01	SCREW ASSY		C	1	
7	4021 0165 03	SCREW ASSY		D	1	
8	4163 5230 03	BUSHING		C	1	
9	4021 5225 01	SEAL		C	2	
10	4163 5226 01	HOLDER		D	2	
11	4163 5298 01	ROLL		C	2	
12	4021 5231 01	BUSHING		C	1	
13	4021 5232 01	GEAR 19T		C	1	
14	4163 5231 02	PRESSURE SPRING		C	2	
15	4021 5226 01	COVER		C	1	
16	4163 5102 01	BUSHING		C	3	
17	4163 5293 01	SCREW		C	5	
18	4021 5213 01	GEAR 20T		C	1	
19	4021 5212 02	GEAR 18T		C	1	
20	4021 5211 01	GEAR 15/15T		C	1	
21	4021 0202 03	BRACKET ASSY		D	1	
22	4021 5227 01	GEAR 19T		C	1	
23	4021 5214 01	GEAR 18/24T		C	1	
24	4163 5101 01	BUSHING		C	3	
25	4021 5219 01	GEAR 15T		C	1	
26	4030 5204 01	SEAL		C	1	
27	4034 5202 01	LID		D	1	
28	4163 5260 01	SEAL		C	2	
29	4021 5221 01	GUIDE		D	1	
30	4163 5229 02	SEAL		C	1	
31	4163 5245 01	MAGNET		D	1	
32	4021 5235 03	BRACKET		D	1	
33	4163 5219 03	REGULATING PLATE		C	1	
34	4163 5271 01	SCREW		D	3	
35	4021 5203 03	SEAL		C	1	
36	4163 5237 01	SEAL		C	1	
37	4163 5272 01	GUIDE		D	1	
38	4002 5042 02	PLATE NUT		D	1	
39	4163 5244 01	MAGNET		D	1	
40	1139 5250 01	PLATE SPRING		C	1	
41	1139 5249 01	SHOULDER SCREW		C	1	
42	4163 6051 02	PWB ASSY		B	1	
43	4163 5221 01	SEAL		C	1	
44	4021 5224 02	CONTACT		C	1	
45	A08E 3700 00	Seal		B	1	

CLEANER SECTION

改訂版 REVISED EDITION	日付 DATE
	JUNE 2007

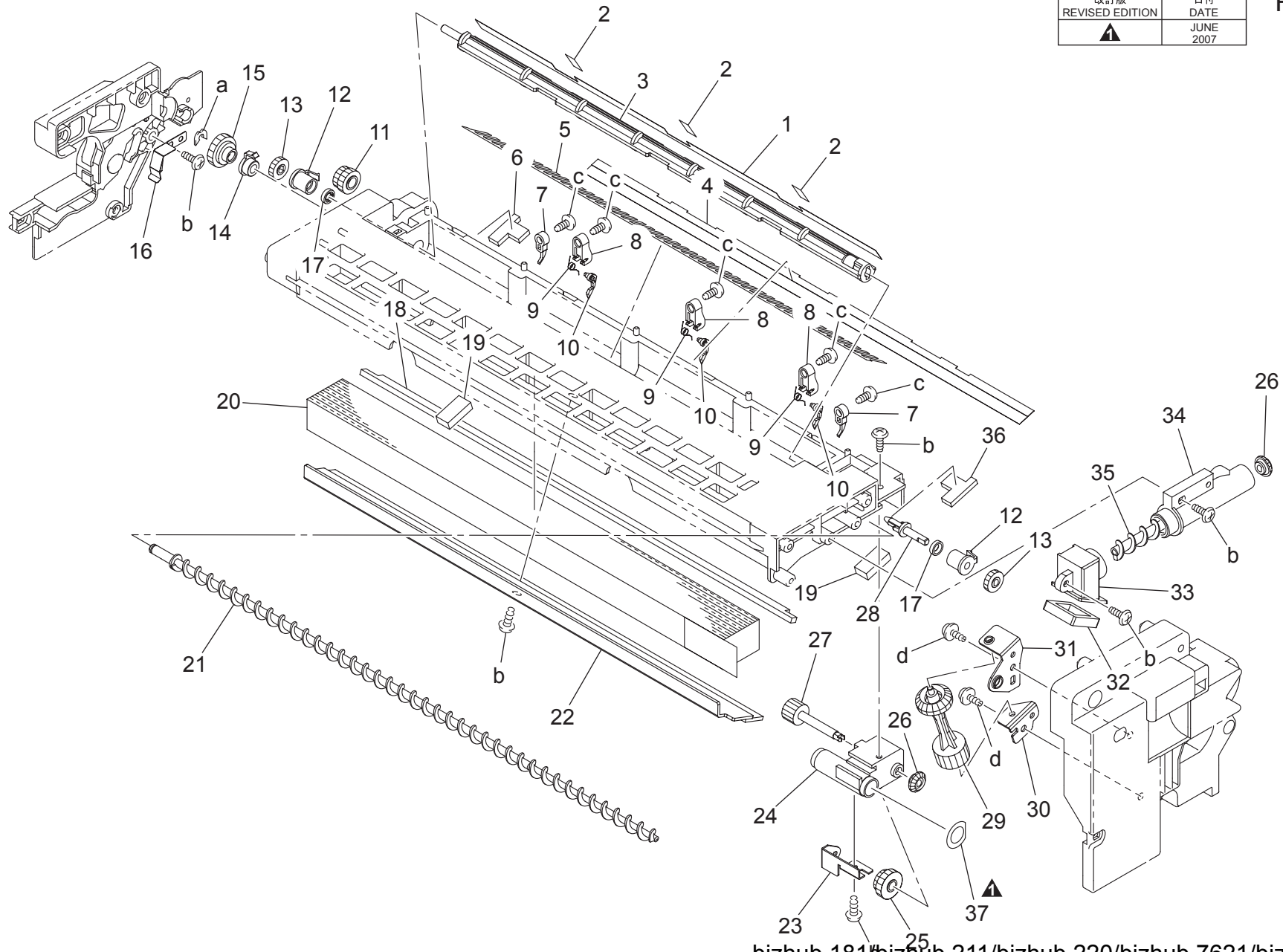

CLEANER SECTION

Key	Part No.	Description	Destinations	Class	QTY	Standard parts
1	4163 5620 01	SEAL		C	1	a-4425 3002 01 b-9742 0308 07 c-9747 1740 07 d-9739 0308 07
2	4021 5623 01	SEAL		C	3	
3	4163 5607 02	SCREW		C	1	
4	4163 5606 04	SEAL		C	1	
5	4163 5617 01	SEAL		C	1	
6	4163 5604 03	SEAL		C	1	
7	4162 4074 01	GUIDE		D	2	
8	4163 4361 04	HOLDER		D	3	
9	4163 4072 01	TORSION SPRING		C	3	
10	4163 4370 01	SEPARATOR		B	3	
11	4021 5618 01	GEAR 14/16T		C	1	
12	4163 5611 01	BUSHING		C	2	
13	4163 5609 01	GEAR 14T		C	2	
14	4163 5625 01	BUSHING		C	1	
15	4021 5619 01	GEAR 22T		C	1	
16	4021 4368 02	PLATE SPRING		D	1	
17	0910 5507 12	SEAL		C	2	
18	4163 5614 01	SEAL		C	1	
19	4163 5603 02	SEAL		C	2	
20	1156 4118 02	OZONE FILTER		A	1	
21	4021 5606 01	SCREW		D	1	
22	4034 5622 01	CLEANING BLADE		A	1	
23	4021 5617 01	BRACKET		D	1	
24	4021 5614 02	HOLDER		D	1	
25	4021 5615 01	GEAR 14/14T		C	1	
26	4163 5639 01	GEAR 14T		C	2	
27	4021 5616 01	GEAR 14T		C	1	
28	4021 0166 02	SHAFT		D	1	
29	4021 5205 01	GEAR 15/18T		C	1	
30	4021 5206 01	BRACKET		D	1	
31	4021 5220 01	BRACKET		D	1	
32	4021 5611 01	SEAL		C	1	
33	4021 5609 01	DUCT		D	1	
34	4021 5607 03	Duct		D	1	
35	4021 5608 01	SCREW		D	1	
36	4163 5605 03	SEAL		C	1	
37	A08E 3701 00	Washer		D	1	

TRANSPORT SECTION

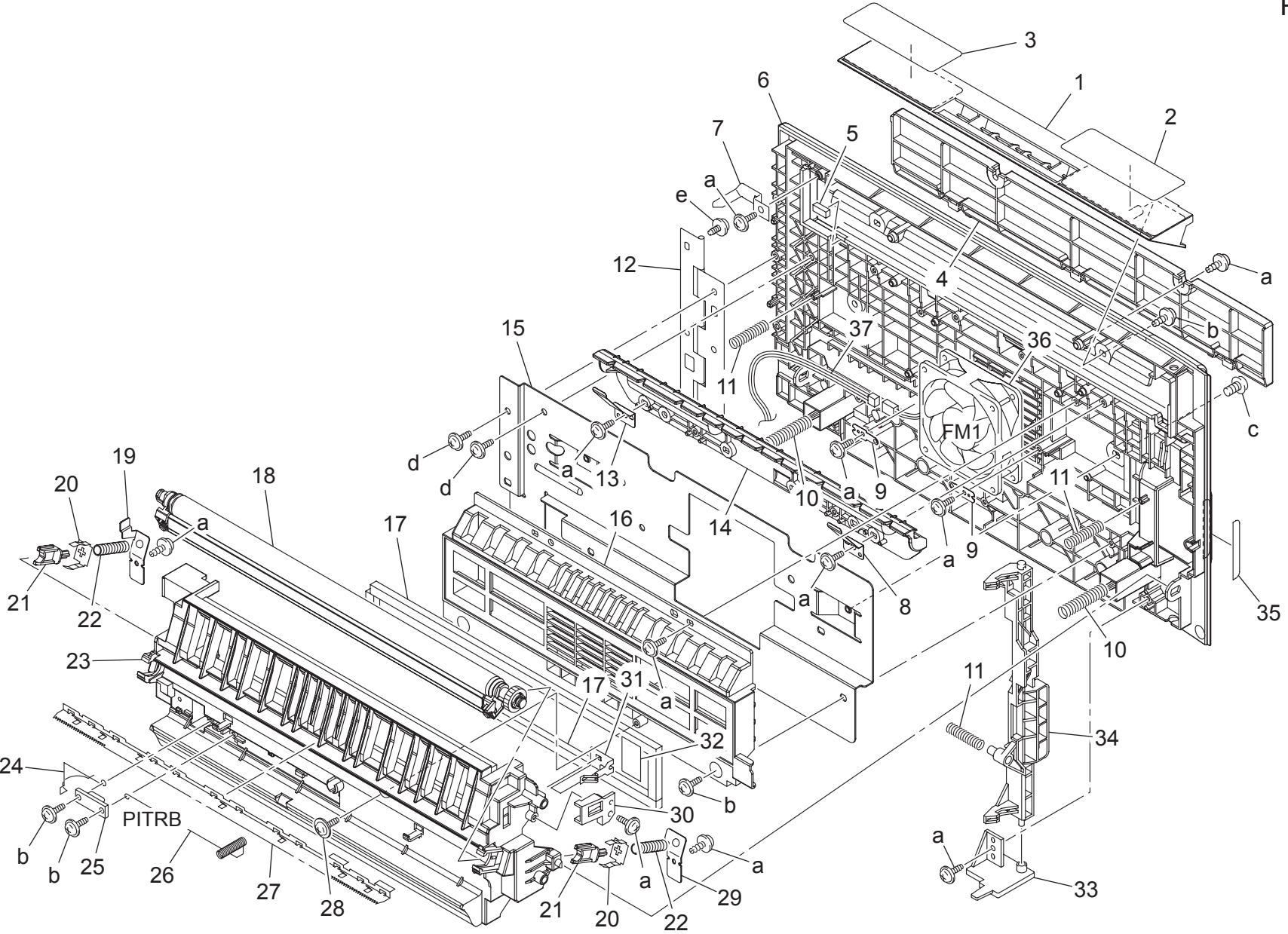

Key	Part No.	Description	Destinations	Class	QTY	Standard parts
1	4034 3510 01	GUIDE		D	1	a-9739 0308 14 b-9739 0310 14 c-9654 0408 14 d-9739 0410 14 e-9735 0408 14
2	4034 7306 01	LABEL JAM REMOVAL		D	1	
3	4034 7333 01	LABEL JAM REMOVAL		C	1	
4	4034 3539 01	COVER		C	1	
5	4034 3550 01	CUSHION		C	1	
6	4034 3538 01	RIGHT DOOR		C	1	
7	4034 3530 02	LEVER		C	1	
8	4034 3519 02	PLATE SPRING		D	1	
9	4192 1464 01	PLATE SPRING		D	2	
10	4011 3515 01	PRESSURE SPRING		C	2	
11	4034 3508 01	PRESSURE SPRING		C	3	
12	4021 2019 02	HINGE		C	1	
13	4034 3535 01	PLATE SPRING		D	1	
14	4034 3511 02	GUIDE		D	1	
15	4034 3514 02	REINFORCE PLATE		D	1	
16	4034 3501 01	DUCT		D	1	
17	4034 3515 01	SEAL		C	2	
18	4034 R706 00	TRANSFER ROLLER ASSY		A	1	
19	4021 4219 01	CONTACT		C	1	
20	1164 4222 01	PLATE SPRING		C	2	
21	1164 4206 02	BUSHING		C	2	
22	1164 4207 01	PRESSURE SPRING		C	2	
23	4034 3503 02	HOLDER		D	1	
24	4034 3517 01	CONTACT		C	1	
25	4011 0112 02	PWB ASSY		C	1	
26	4034 3518 01	CONTACT		C	1	
27	1164 4202 04	NEUTRALIZING NEEDLE		D	1	
28	4163 5293 01	SCREW		C	1	
29	4021 4209 02	CONTACT		C	1	
30	4034 3512 02	HOLDER		D	1	
31	4034 3513 02	CONTACT		C	1	
32	4011 5858 01	SEAL		C	1	
33	4021 2307 01	LEVER		C	1	
34	4034 2301 01	LEVER		C	1	
35	4034 7310 01	LABEL		C	1	
36	9313 1300 31	FAN MOTOR		B	1	
37	4034 6840 01	WIRE HARNESS ASSY		D	1	

FUSING SECTION

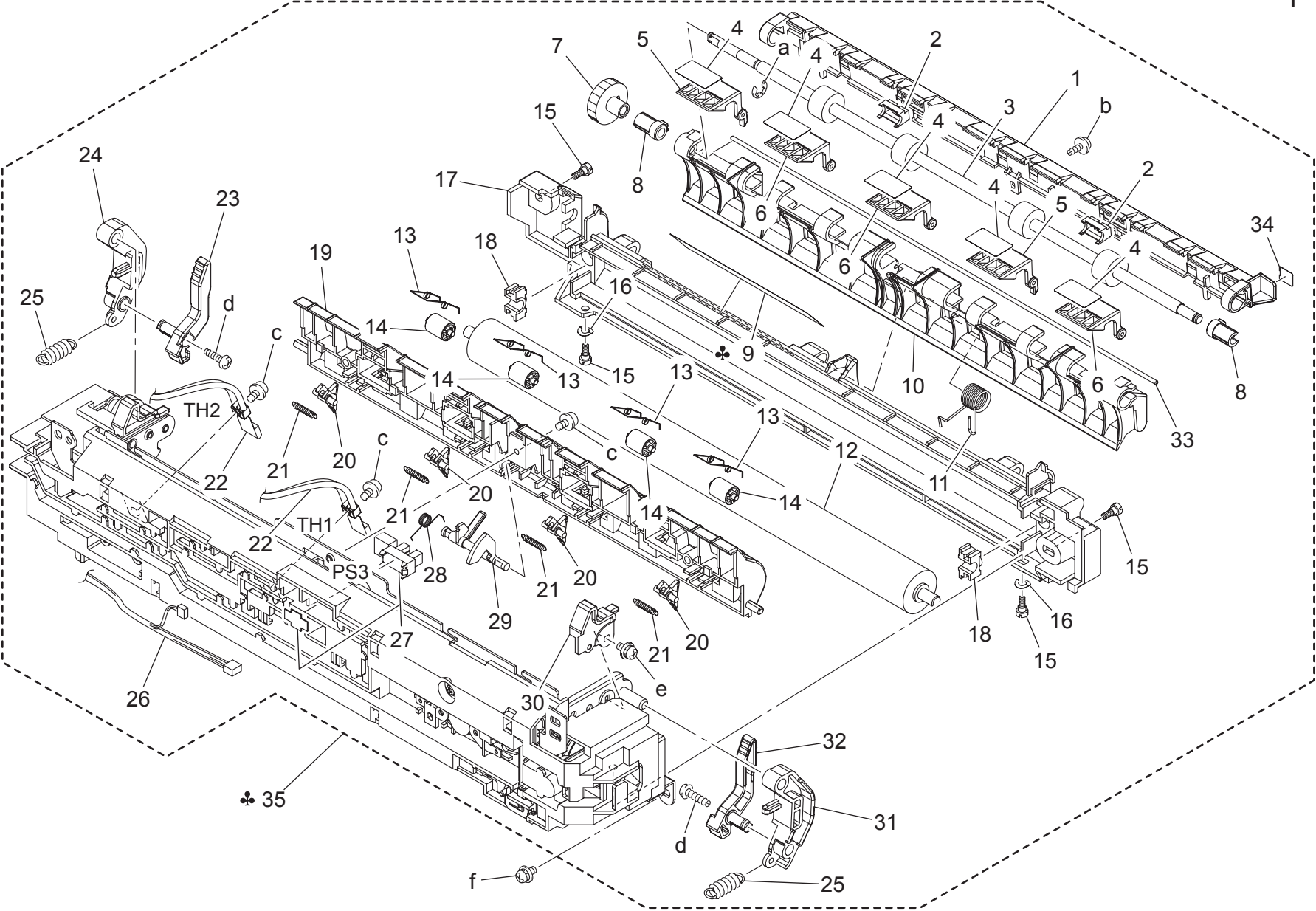

FUSING SECTION

Key	Part No.	Description	Destinations	Class	QTY	Standard parts
1	4034 5782 01	COVER		C	1	a-9721 0300 01 b-9739 0308 14 c-9646 0306 14 d-9732 0314 14 e-9646 0308 14 f-9646 0310 14
2	4034 5763 01	COLLAR		C	2	
3	4034 5751 01	ROLLER		C	1	
4	4011 5858 01	SEAL		C	5	
5	4034 5785 01	GUIDE		D	2	
6	4034 5784 01	GUIDE		D	3	
7	4034 5756 01	GEAR 21T		C	1	
8	4034 5753 01	BUSHING		C	2	
9	4034 7402 01	LABEL CAUTION	B,H,F1,G2	C	1	
9	4034 7403 01	LABEL CAUTION	D1,D3,E,F2,G1,I,J,K	C	1	
9	4034 7404 01	LABEL CAUTION	C	C	1	
10	4034 5714 02	GUIDE		D	1	
11	4034 5715 01	TORSION SPRING		C	1	
12	4034 5702 02	FUSING ROLLER		C	1	
13	4034 5755 01	TORSION SPRING		C	4	
14	4034 5752 01	ROLL		C	4	
15	4021 5742 01	SHOULDER SCREW		C	4	
16	1164 5765 01	SPACER		C	2	
17	4034 5708 03	COVER		C	1	
18	4034 5711 01	BUSHING		C	2	
19	4034 5716 01	GUIDE		D	1	
20	4021 5720 02	SEPARATOR		A	4	
21	4034 5787 01	TENSION SPRING		C	4	
22	9372 2300 41	THERMISTOR		B	2	
23	4021 5726 03	LEVER		C	1	
24	4021 5733 01	LEVER		C	1	
25	4021 5727 12	TENSION SPRING		C	2	
26	4034 6827 01	WIRE HARNESS ASSY		D	1	
27	4037 0906 01	PHOTO INTERRUPTER		B	1	
28	4034 5723 01	TORSION SPRING		C	1	
29	4034 5722 01	ACTUATOR		D	1	
30	4034 5761 01	POSITIONING PLATE		D	1	
31	4021 5724 01	LEVER		C	1	
32	4021 5725 03	LEVER		C	1	
33	4034 5786 01	SHAFT		D	1	
34	4034 5741 01	LABEL		C	1	
35	4034 0751 00	FUSING UNIT 120V	B,F1,G2	A	1	
35	4034 R700 00	FUSING UNIT 230V	D1,D3,E,F2,G1,I,J,K	A	1	
35	4034 R701 00	FUSING UNIT 230V	C	A	1	
35	A08E R703 00	FUSING UNIT 110V	H	A	1	

PAPER EXIT SECTION

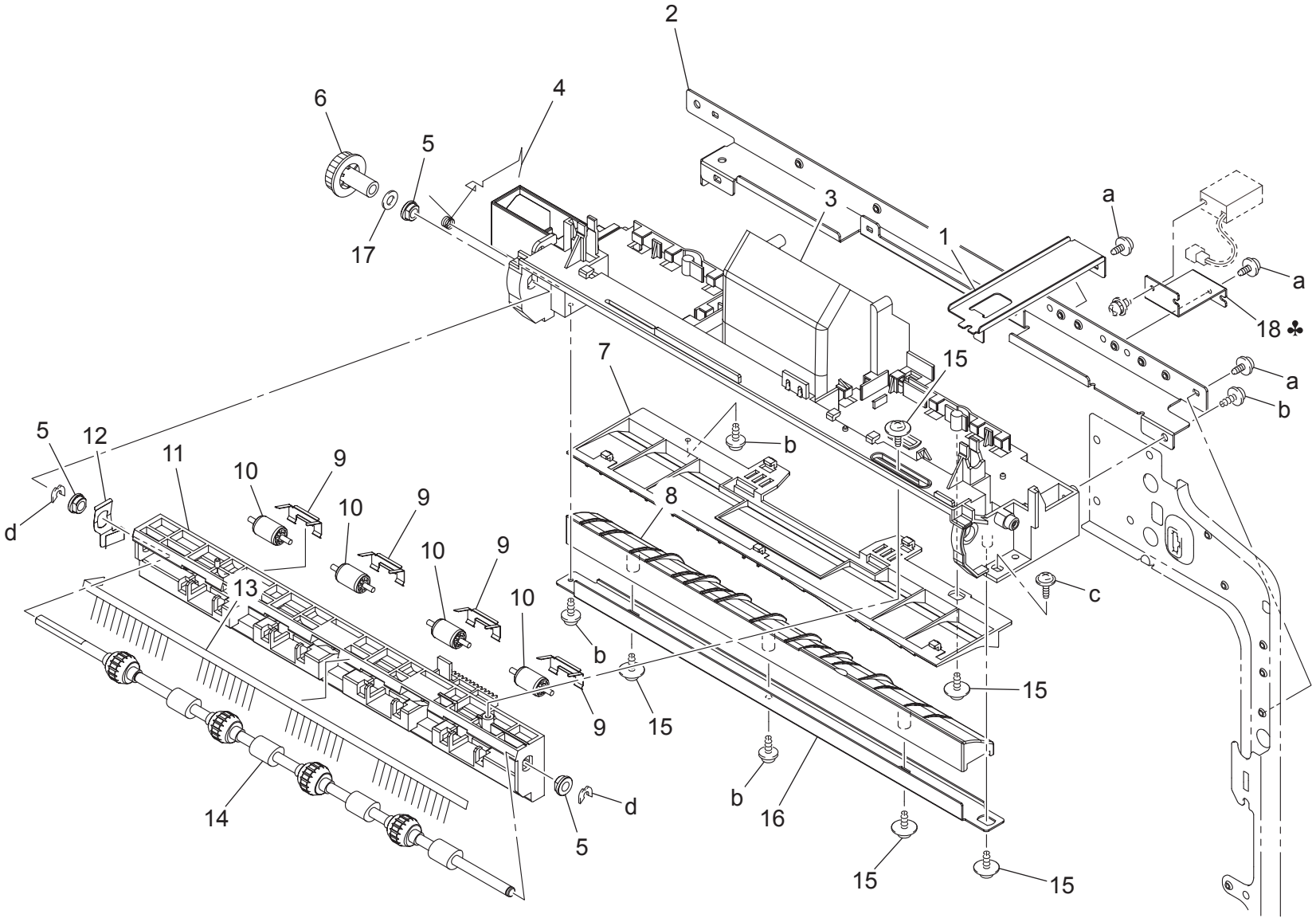

PAPER EXIT SECTION

Key	Part No.	Description	Destinations	Class	QTY	Standard parts
1	4021 5824 01	STOPPER		D	1	a-9735 0306 14 b-9739 0308 14 c-9739 0410 14 d-4425 3001 01
2	4034 2012 01	REINFORCE PLATE		D	1	
3	4034 5807 02	FRAME		D	1	
4	4021 5815 01	SPRING		C	1	
5	1134 3043 01	BUSHING		C	3	
6	4034 5806 02	GEAR 26T		C	1	
7	4034 5802 01	GUIDE		D	1	
8	4034 5803 01	GUIDE		D	1	
9	4034 5808 01	PLATE SPRING		D	4	
10	4021 5802 01	ROLL		C	4	
11	4034 5805 02	FRAME		D	1	
12	4021 5819 01	SET PLATE		C	1	
13	4021 5814 01	NEUTRALIZING BRUSH		C	1	
14	4034 5801 01	ROLLER		C	1	
15	4163 5293 01	SCREW		C	5	
16	4034 5804 01	BRACKET		D	1	
17	4034 5809 01	WASHER		C	1	
18	4022 2255 01	BRACKET	B	D	1	

DRIVE SECTION

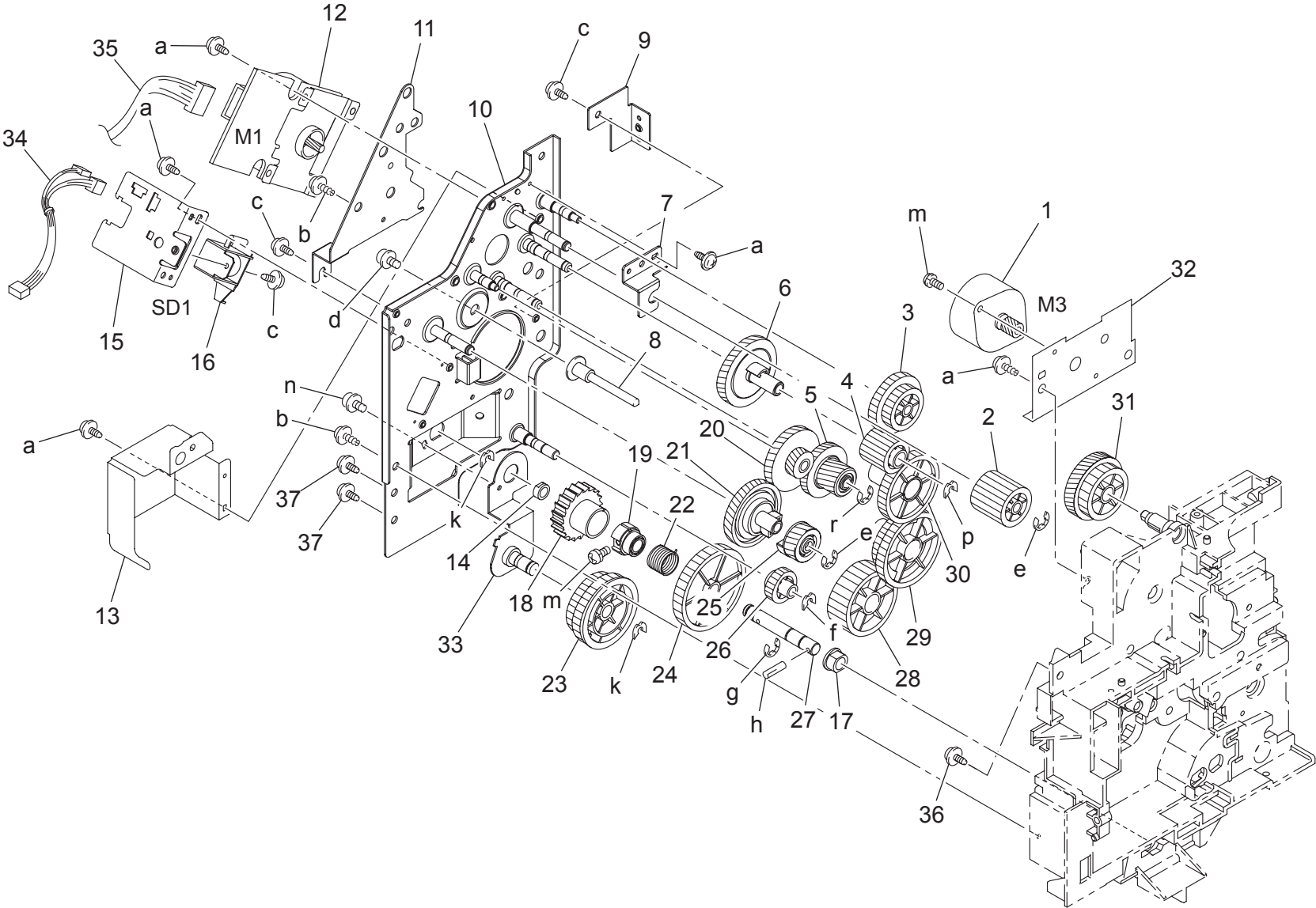

DRIVE SECTION

Key	Part No.	Description	Destinations	Class	QTY	Standard parts
1	9314 1300 11	MOTOR		B	1	a-9735 0306 14
2	4021 2512 01	GEAR 24T		C	1	b-9739 0408 14
3	4021 2511 01	GEAR 26/49T		C	1	c-9735 0308 14
4	4021 2510 01	GEAR 27T		C	1	d-9646 0308 14
5	4021 2502 01	GEAR 22/62T		C	1	e-9721 0400 01
6	4021 2505 01	GEAR 82T		C	1	f-4425 3001 01
7	4021 2538 01	BRACKET		D	1	g-9721 0600 01
8	4021 2519 01	SHAFT		D	1	h-9754 3022 08
9	4034 2538 01	BRACKET		D	1	k-1066 1151 01
10	4034 0201 02	DRIVING ASSY		D	1	m-9644 0308 14
11	4034 2536 01	FRAME		D	1	n-9646 0305 14
12	9J06 M102 00	MOTOR		B	1	p-9723 0500 89
13	4034 2550 01	BRACKET		D	1	r-9721 0500 01
14	4658 3516 01	BUSHING		C	1	
15	4034 2540 01	BRACKET		D	1	
16	4034 M200 00	SOLENOID		C	1	
17	4021 2547 02	BUSHING		C	1	
18	4021 2540 01	RATCHET		C	1	
19	4021 2542 01	BUSHING		C	1	
20	4021 2501 01	GEAR 31/76T		C	1	
21	4021 2503 01	GEAR 77T		C	1	
22	4021 2541 01	TORSION SPRING		B	1	
23	4021 2517 01	GEAR 44/52T		C	1	
24	4021 2509 01	GEAR 70T		C	1	
25	4021 2504 01	GEAR 19T		C	1	
26	4034 2517 01	GEAR 26T		C	1	
27	4021 2533 03	SHAFT		D	1	
28	4034 2508 01	GEAR 56T		C	1	
29	4034 2507 01	GEAR 50/64T		C	1	
30	4034 2506 01	GEAR 58T		C	1	
31	4034 2515 03	GEAR 32/75T		C	1	
32	4034 2537 01	BRACKET		D	1	
33	4021 0204 01	BRACKET ASSY		D	1	
34	4034 6821 01	WIRE HARNESS ASSY		D	1	
35	4034 6810 02	WIRE HARNESS ASSY		D	1	
36	4154 3804 01	SCREW		C	1	
37	4106 2063 01	SCREW		C	2	

ELECTRICAL COMPONENTS

改訂版 REVISED EDITION	日付 DATE
	SEPTEMBER 2007

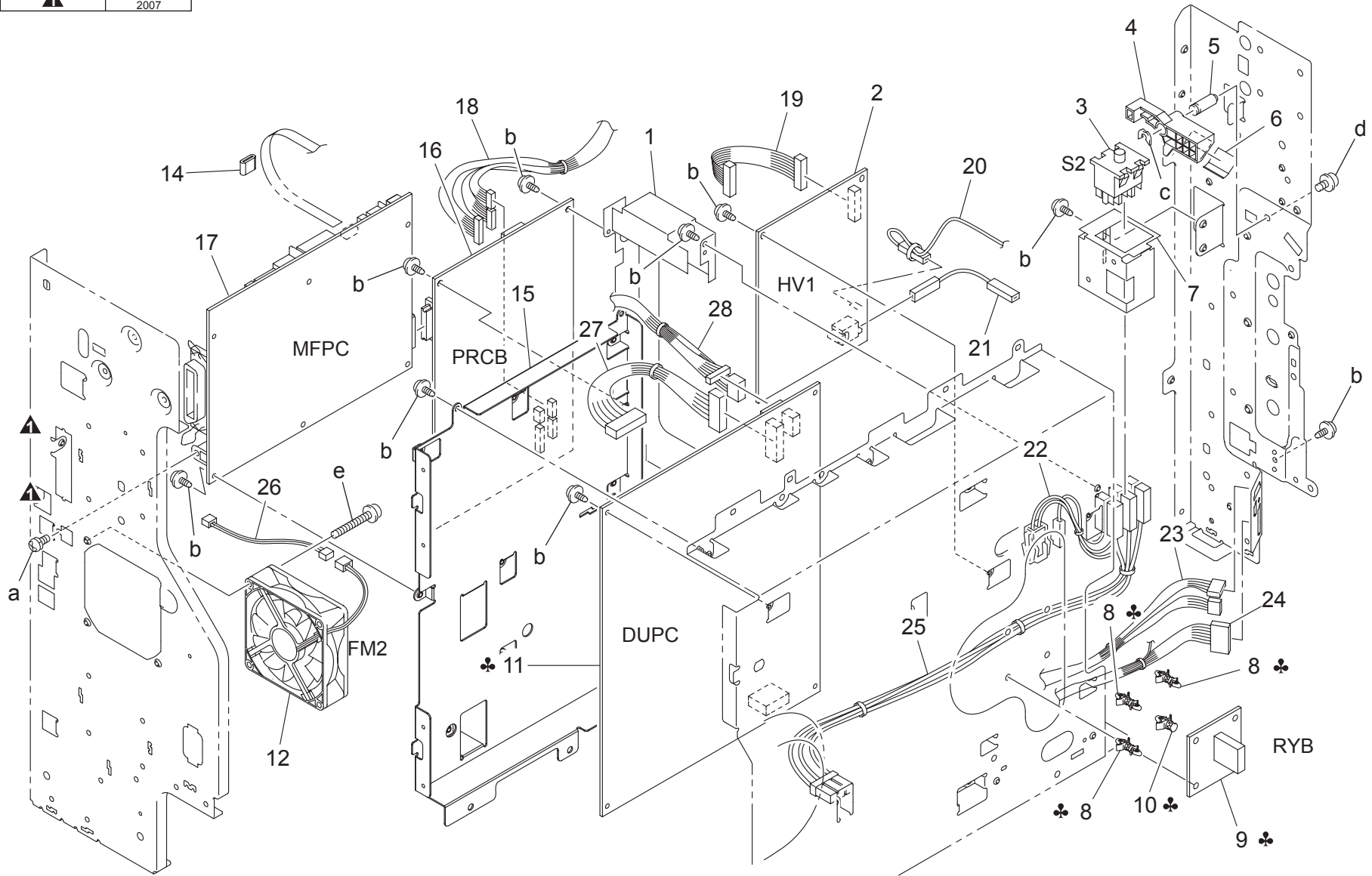

ELECTRICAL COMPONENTS

Key	Part No.	Description	Destinations	Class	QTY	Standard parts
1	4034 2202 01	BRACKET		D	1	a-9644 0308 14 b-9735 0308 14 c-1066 1151 01 d-9646 0308 14 e-9735 0330 14
2	4034 6205 04	HV TRANSFORMER		I	1	
3	4040 M600 00	Micro switch		C	1	
4	4034 2032 01	LEVER		C	1	
5	4021 2020 01	SHAFT		D	1	
6	4034 2033 01	INSTRUCTIONS		C	1	
7	4034 2016 02	BRACKET		D	1	
8	9384 1900 56	PWB SUPPORT 6.35H	C,D1,D3,E,F2,G1,I,K,J	D	3	
9	4034 0125 01	PWB ASSY	C,D1,D3,E,F2,G1,I,K,J	I	1	
10	9384 1621 21	PWB SUPPORT 6.4H	C,D1,D3,E,F2,G1,I,K,J	D	1	
11	4034 6201 02	POWER SUPPLY	B,H,F1,G2	I	1	
11	4034 6202 06	POWER SUPPLY	C,D1,D3,E,F2,G1,I,K,J	I	1	
12	9J03 M100 00	FAN MOTOR		B	1	
14	9326 1000 51	FERRITE CORE		D	1	
15	A08E 1300 00	BRACKET		D	1	
16	4034 0121 05	PWB ASSY		I	1	
17	A08E M700 00	PWB Assy		I	1	
18	4034 6825 02	WIRE HARNESS ASSY		D	1	
19	4034 6813 01	WIRE HARNESS ASSY		D	1	
20	4034 6837 01	WIRE HARNESS ASSY		C	1	
21	4034 6834 01	WIRE HARNESS ASSY		D	1	
22	4034 6806 01	WIRE HARNESS ASSY		D	1	
23	4034 6817 01	WIRE HARNESS ASSY		D	1	
24	4034 6847 01	WIRE HARNESS ASSY		D	1	
25	4034 6805 01	WIRE HARNESS ASSY		D	1	
26	4034 6881 02	WIRE HARNESS ASSY		D	1	
27	4034 6811 01	WIRE HARNESS ASSY		D	1	
28	4034 6812 01	WIRE HARNESS ASSY		D	1	

CASSETTE SECTION

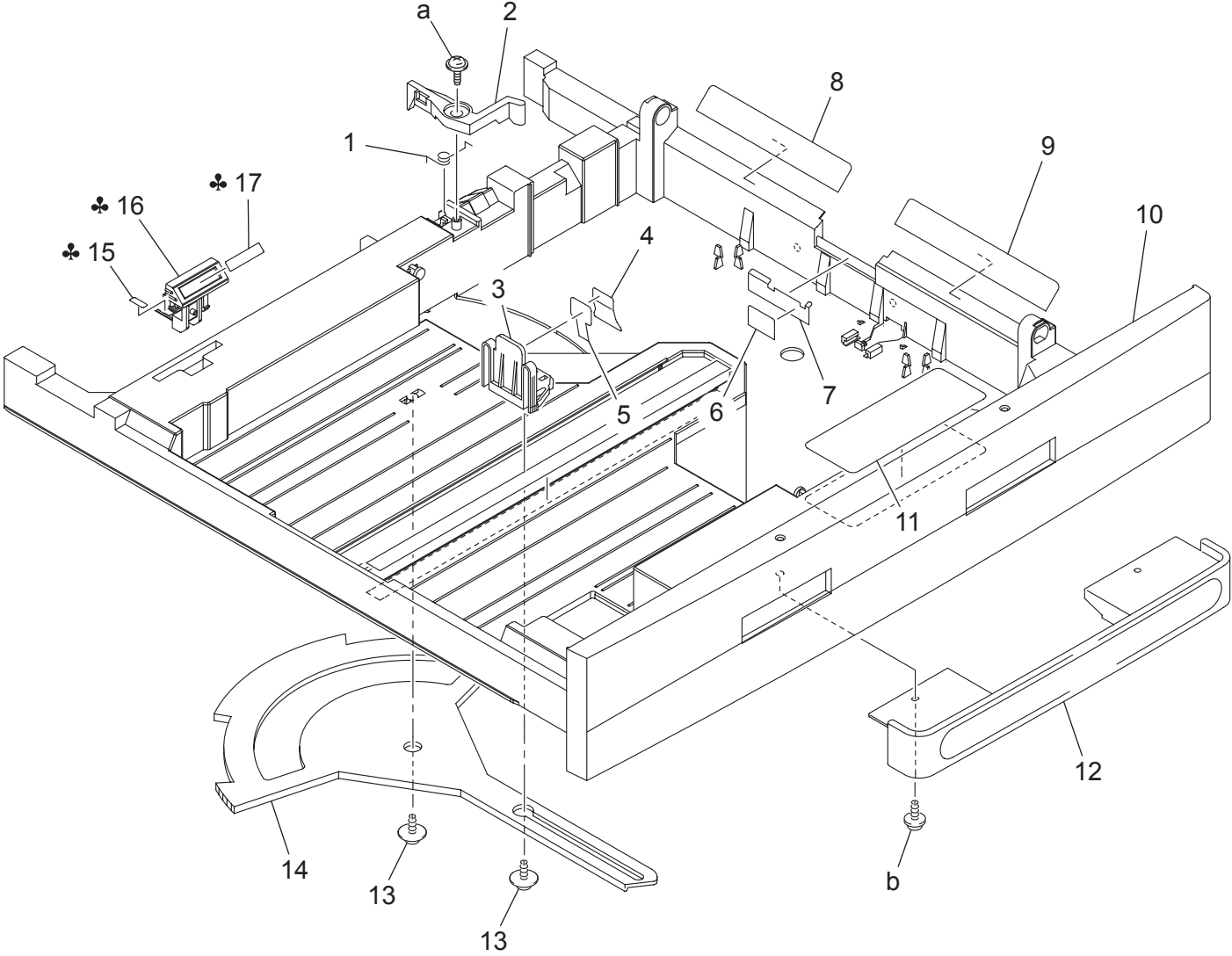

CASSETTE SECTION

Key	Part No.	Description	Destinations	Class	QTY	Standard parts
1	4011 3005 01	TORSION SPRING		C	1	a-V153 0308 03 b-V153 0410 03
2	4011 3002 01	LEVER		C	1	
3	4034 3014 01	REGULATING PLATE		C	1	
4	4021 3035 02	GUIDE		C	1	
5	4021 3036 01	GUIDE		C	1	
6	4021 3032 12	GUIDE		C	1	
7	4021 3031 13	GUIDE PLATE		D	1	
8	4021 3019 01	GUIDE		C	1	
9	4021 3020 01	GUIDE		C	1	
10	4021 3001 28	Cassette		D	1	
11	4034 7330 01	LABEL PAPER SET		C	1	
12	4034 3005 01	HANDLE		C	1	
13	4163 5293 01	SCREW		C	2	
14	4686 3350 01	LEVER		C	1	
15	4034 3017 01	SHIELD PLATE	D1,D3,E,F1,F2,G1,G2,I,K	C	1	
16	4034 3016 01	LEVER	D1,D3,E,F1,F2,G1,G2,I,K	C	1	
17	1151 7383 01	LABEL	D1,D3,E,F1,F2,G1,G2,I,K	C	1	

CASSETTE SECTION

改訂版 REVISED EDITION	日付 DATE
▲	AUGUST 2007

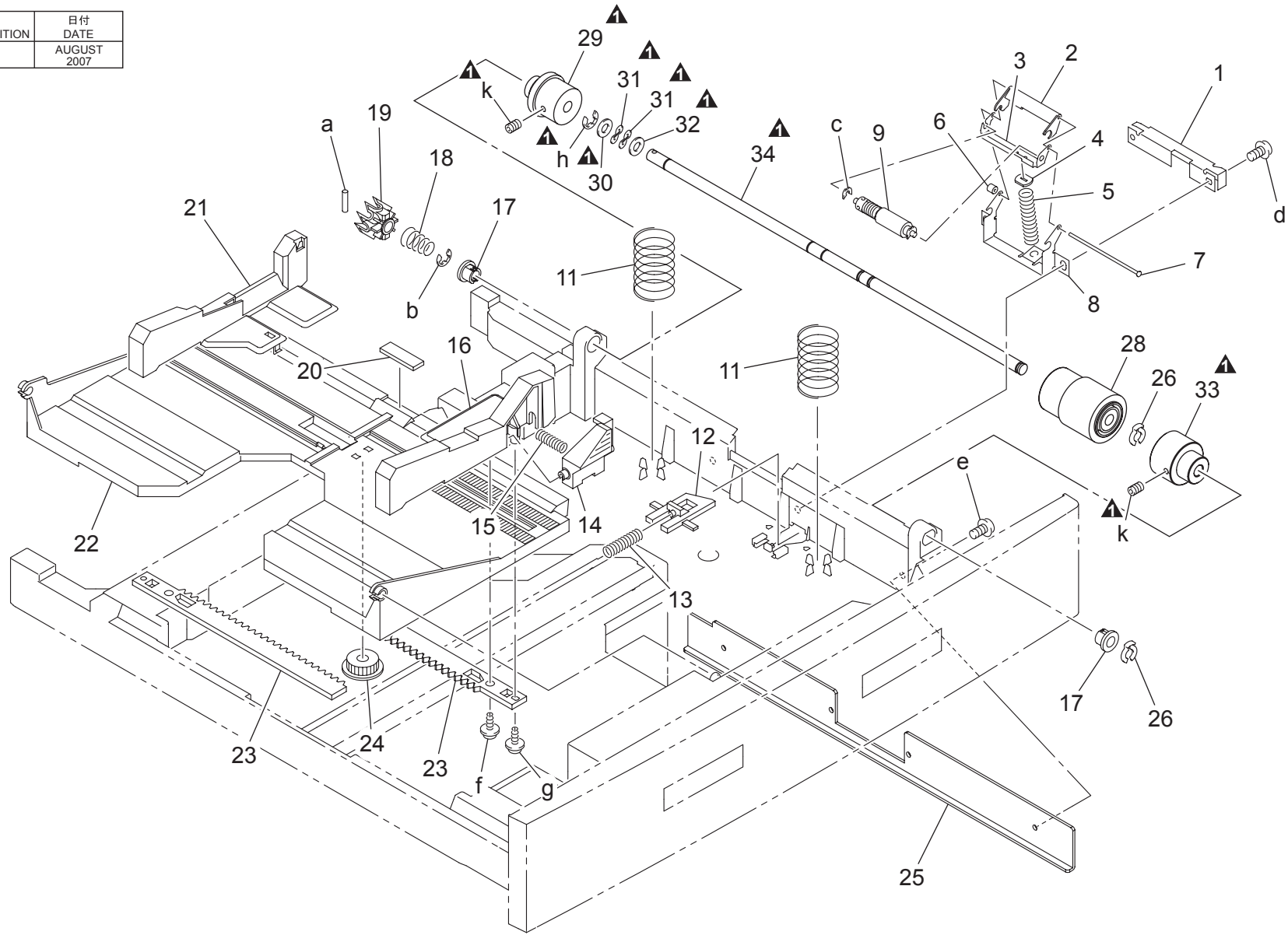

CASSETTE SECTION

Key	Part No.	Description	Destinations	Class	QTY	Standard parts	
1	4021 3037 02	REGULATING PLATE		C	1	a-4036 3014 01 b-9721 0600 01 c-4425 3002 01 d-9654 0408 14 e-V118 0408 03 f-V153 0308 03 g-9739 0312 14 h-9721 0600 01 k-9684 0406 08	
2	4658 3035 02	GUIDE		D	1		
3	4021 3013 02	HOLDER		D	1		
4	1144 3097 03	HOLDER		D	1		
5	4004 3006 03	PRESSURE SPRING		C	1		
6	4038 5655 00	COLLAR		D	1		
7	4658 3040 01	SHAFT		D	1		
8	4021 3014 02	BRACKET		D	1		
9	4034 0151 01	SEPARATION ROLLER		A	1		
11	1164 3047 02	PRESSURE SPRING		C	2		
12	1164 3061 01	LEVER		C	1		
13	1164 3062 01	PRESSURE SPRING		C	1		
14	4037 3210 01	LEVER		C	1		
15	4038 5601 00	PRESSURE SPRING		C	1		
16	4011 3008 06	Regulating plate		C	1		
17	1164 3003 01	BUSHING		C	2		
18	1164 3005 02	PRESSURE SPRING		C	1		
19	1164 3004 03	PAWL		C	1		
20	4687 3281 01	FRICTION SHEET		C	1		
21	4011 3009 01	REGULATING PLATE		C	1		
22	4011 3007 03	LIFTING PLATE		D	1		
23	1164 3049 02	RACK		C	2		
24	1164 3045 01	GEAR 20T		C	1		
25	A08E 5600 00	Reinforce plate		D	1		
26	4658 3046 01	STOP RING		C	2		
28	4034 3012 01	ROLLER		A	1		
29	4038 3063 01	WEIGHT		D	1		
30	4011 3021 01	WASHER		C	1		
31	4011 3020 01	WASHER		C	2		
32	4021 3009 01	WASHER		D	1		
33	A08E 5601 00	Weight		D	1		
34	4021 3002 05	SHAFT		D	1		

PAPER FEEDER UNIT

CHINA ONLY

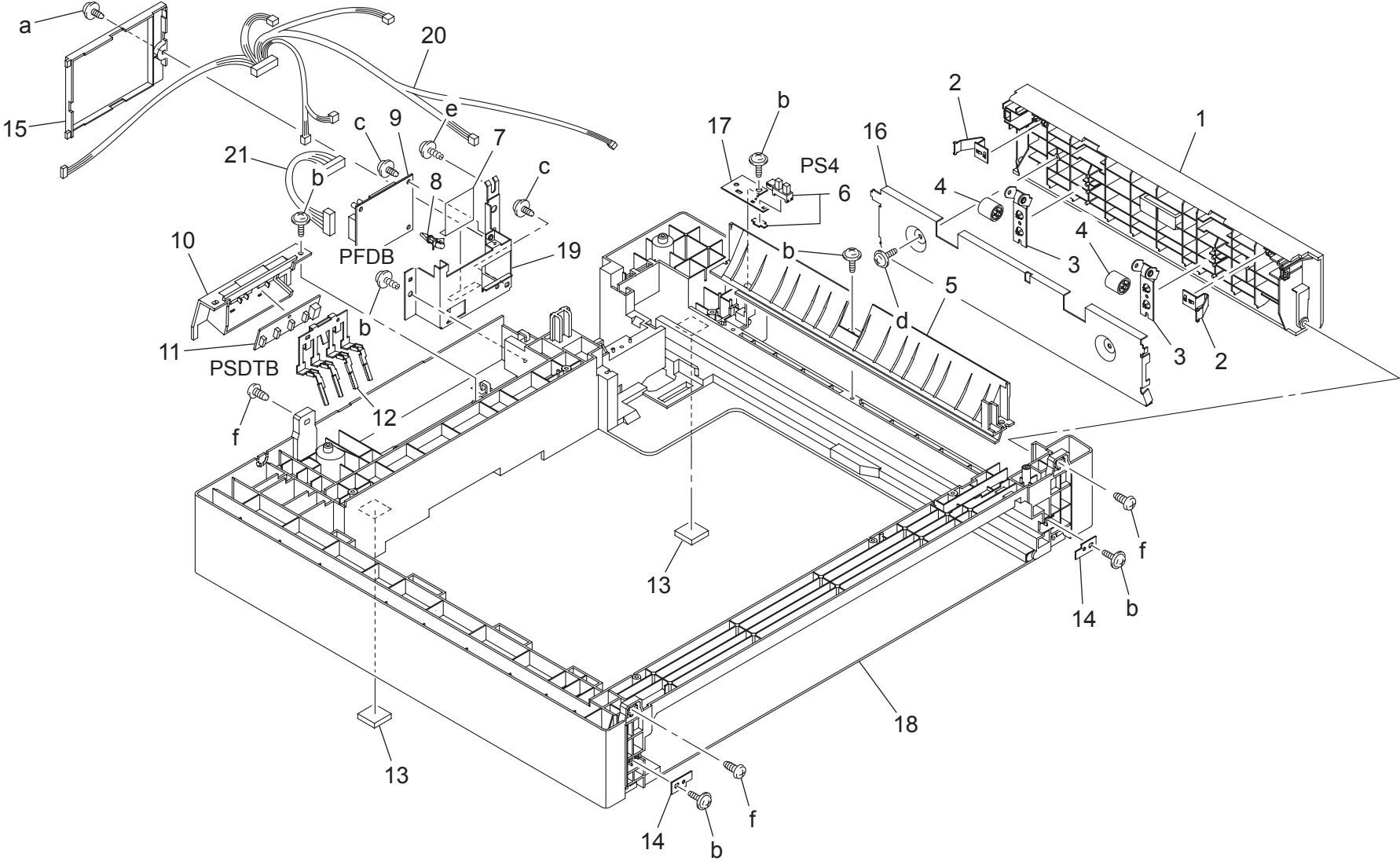

PAPER FEEDER UNIT

Key	Part No.	Description	Destinations	Class	QTY	Standard parts
1	4686 3372 01	DOOR	J	C	1	a-9654 0306 14 b-9739 0410 14 c-9735 0306 14 d-9739 0308 14 e-9739 0408 14 f-9742 0412 14
2	4686 3335 01	PLATE SPRING	J	C	2	
3	4686 3362 01	PLATE SPRING	J	C	2	
4	4686 3364 01	ROLL	J	C	2	
5	4686 3318 01	GUIDE	J	D	1	
6	4686 0903 01	PHOTO INTERRUPTER	J	B	1	
7	4686 3369 01	SHEET	J	C	1	
8	9384 1900 56	PWB SUPPORT 6.35H	J	D	1	
9	4686 0121 01	PWB Assy	J	I	1	
10	4021 3004 01	HOLDER	J	D	1	
11	4037 0104 01	PWB ASSY	J	C	1	
12	1164 3020 03	LEVER	J	C	1	
13	4156 3826 01	RUBBER FOOT	J	D	2	
14	4686 3304 01	STOPPER	J	D	2	
15	4686 3373 01	COVER	J	C	1	
16	4686 3317 02	GUIDE PLATE	J	D	1	
17	4686 3319 01	BRACKET	J	D	1	
18	4686 3374 01	BASE FRAME	J	D	1	
19	4686 3306 03	BRACKET	J	D	1	
20	4686 6801 02	WIRE HARNESS ASSY	J	D	1	
21	4686 6802 04	WIRE HARNESS ASSY	J	D	1	

PAPER FEEDER UNIT

CHINA ONLY

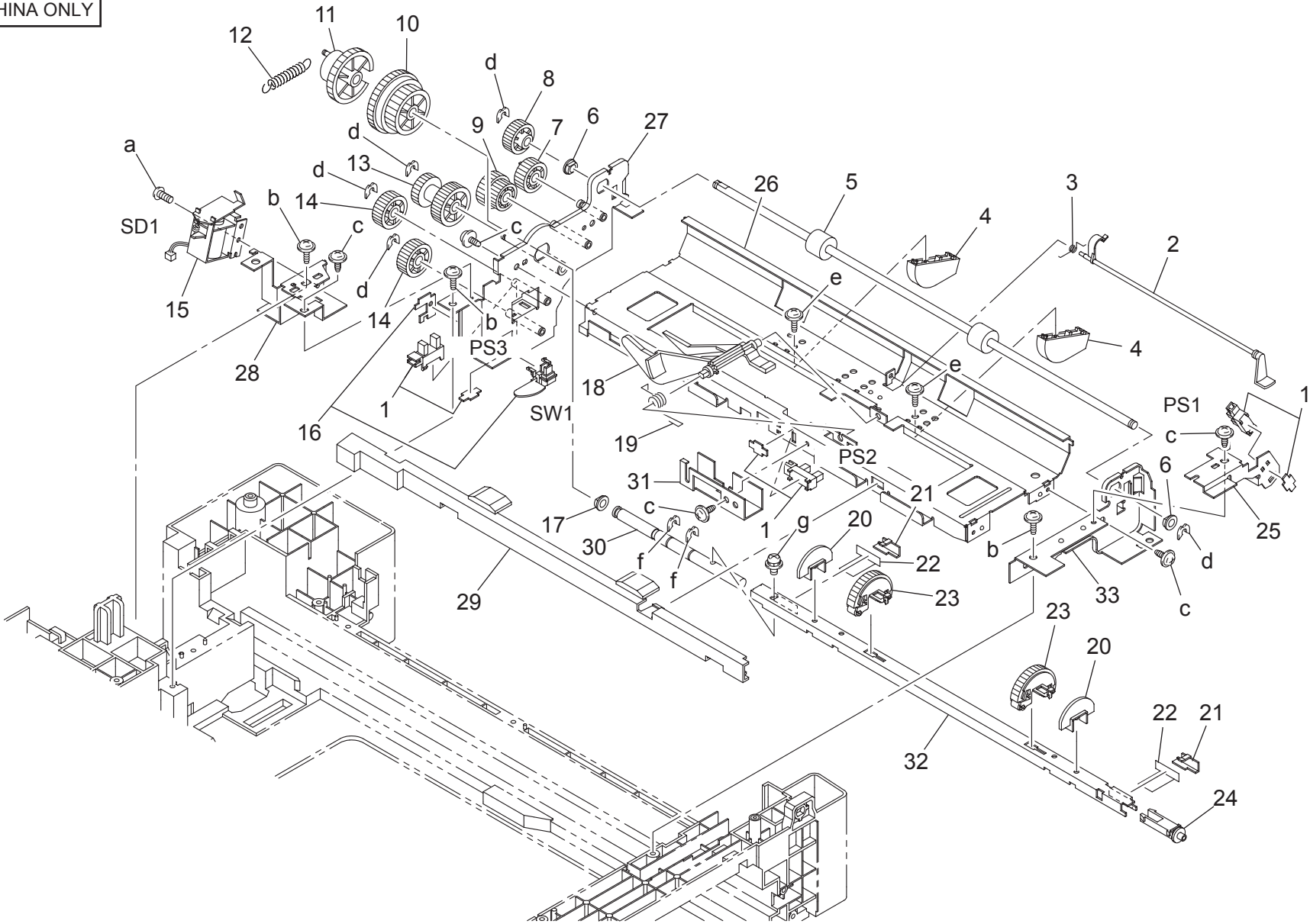

PAPER FEEDER UNIT

Key	Part No.	Description	Destinations	Class	QTY	Standard parts
1	4686 0903 01	PHOTO INTERRUPTER	J	B	3	a-9743 0306 14 b-9739 0410 14 c-9735 0306 14 d-4425 3001 01 e-9739 0308 14 f-1066 1151 01 g-9646 0308 14
2	4686 3310 01	ACTUATOR	J	C	1	
3	4686 3334 01	TORSION SPRING	J	C	1	
4	4686 3337 01	GUIDE	J	D	2	
5	4686 3360 01	ROLLER	J	C	1	
6	1139 3169 01	BUSHING	J	C	2	
7	4686 3351 01	GEAR 20T	J	C	1	
8	4686 3361 01	GEAR 18T	J	C	1	
9	4686 3343 01	GEAR 17/19T	J	C	1	
10	4686 3307 01	GEAR 29/38T	J	C	1	
11	4686 3358 01	GEAR	J	C	1	
12	4686 3359 01	TENSION SPRING	J	C	1	
13	4686 3308 01	GEAR 20/25T	J	C	1	
14	4686 3341 01	GEAR 22T	J	C	2	
15	9321 2100 22	SOLENOID	J	C	1	
16	4686 0902 01	PUSHBUTTON SWITCH	J	C	1	
17	4011 2504 01	BUSHING	J	C	1	
18	4686 3336 01	ACTUATOR	J	C	1	
19	4686 3353 01	TORSION SPRING	J	C	1	
20	4686 3312 01	COLLAR	J	C	2	
21	4686 3357 01	HOLD PLATE	J	D	2	
22	4686 3356 01	SEAL	J	C	2	
23	4686 3371 01	FEED ROLLER	J	A	2	
24	4686 3354 01	JOINT	J	D	1	
25	4686 3333 01	BRACKET	J	D	1	
26	4686 3355 01	GUIDE PLATE	J	D	1	
27	4686 0210 01	BRACKET ASSY	J	D	1	
28	4686 3316 01	BRACKET	J	D	1	
29	4658 3144 02	COVER	J	D	1	
30	4686 3313 01	SHAFT	J	D	1	
31	4498 3328 01	BRACKET	J	D	1	
32	4498 3333 02	AXLE PLATE	J	D	1	
33	4686 3314 01	FRAME	J	D	1	

PAPER FEEDER UNIT

CHINA ONLY

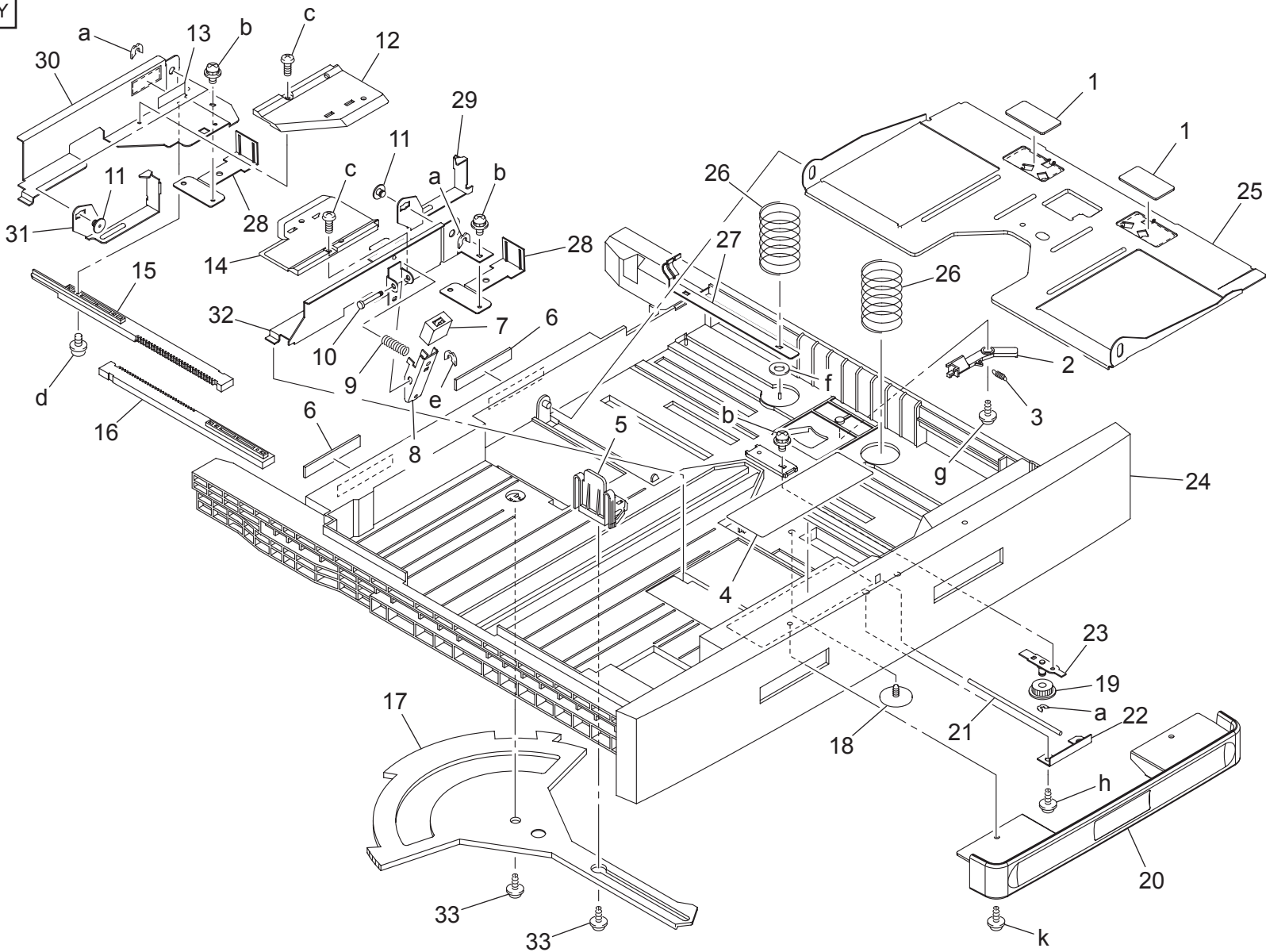

PAPER FEEDER UNIT

Key	Part No.	Description	Destinations	Class	QTY	Standard parts
1	4686 3365 01	FRICION SHEET	J	C	2	a-4425 3001 01 b-9646 0306 14 c-9743 0306 14 d-9646 0310 14 e-4425 3002 01 f-9716 0400 01 g-9739 0308 14 h-9739 0408 14 k-9739 0410 14
2	4686 3328 01	LEVER	J	C	1	
3	4498 3404 01	TENSION SPRING	J	C	1	
4	4686 7315 01	LABEL PAPER SET	J	D	1	
5	4034 3014 01	REGULATING PLATE	J	C	1	
6	4498 3833 01	FRICION SHEET	J	C	2	
7	4686 3375 01	KNOB	J	C	1	
8	4686 3346 01	LEVER	J	C	1	
9	4686 3347 01	PRESSURE SPRING	J	C	1	
10	4498 3826 01	SHAFT	J	D	1	
11	4498 3345 04	HOLD PLATE	J	D	2	
12	4686 3322 01	COVER	J	D	1	
13	4002 7306 01	LABEL CARRYING CAPACITY	J	C	1	
14	4686 3321 01	COVER	J	D	1	
15	4686 3326 03	RACK	J	D	1	
16	4686 3325 02	RACK	J	D	1	
17	4686 3350 01	LEVER	J	C	1	
18	4109 2003 01	SHOULDER SCREW	J	C	1	
19	4686 3329 01	GEAR 14T	J	C	1	
20	4034 3005 01	HANDLE	J	C	1	
21	4686 3348 02	SHAFT	J	D	1	
22	4686 3349 01	BRACKET	J	D	1	
23	4686 0211 01	BRACKET ASSY	J	D	1	
24	4686 3320 14	CASSETTE	J	D	1	
25	4686 3327 01	LIFTING PLATE	J	D	1	
26	4686 3366 01	PRESSURE SPRING	J	C	2	
27	4686 3330 01	PLATE SPRING	J	D	1	
28	4686 3367 01	REINFORCE PLATE	J	D	2	
29	0996 3022 01	PAWL	J	D	1	
30	4686 3324 02	REGULATING PLATE	J	D	1	
31	0996 3023 01	PAWL	J	D	1	
32	4686 3323 02	REGULATING PLATE	J	D	1	
33	4163 5293 01	SCREW	J	C	2	

WIRING ACCESSORIES AND JIGS

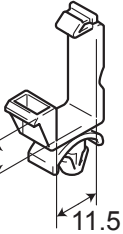
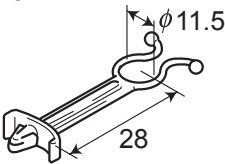
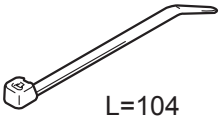
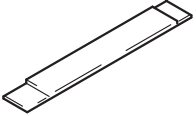
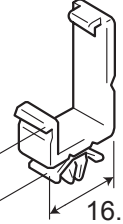
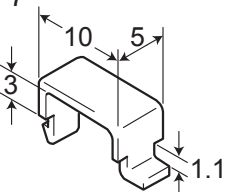
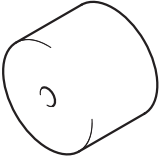
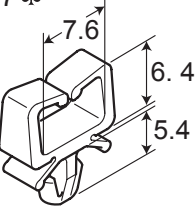
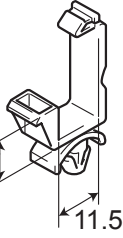
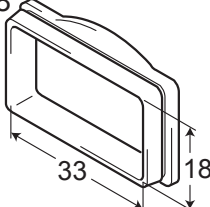
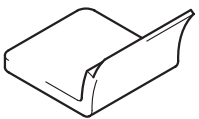
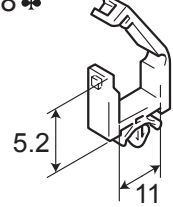
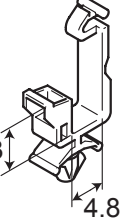
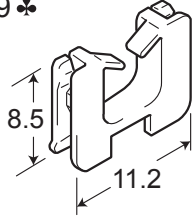
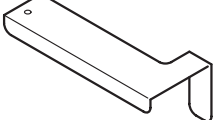
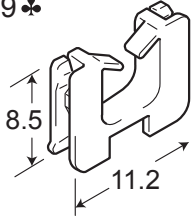
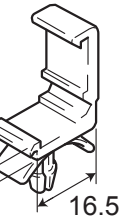
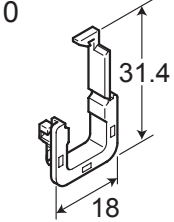
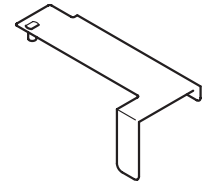
1♣ 	6 	11♣ 	16 	21	26	31	36
2 	7 	12 	17♣ 	22	27	32	37
3♣ 	8 	13 	18♣ 	23	28	33	38
4♣ 	9♣ 	14 	19♣ 	24	29	34	39
5 	10 	15 	20	25	30	35	40

WIRING ACCESSORIES AND JIGS

Key	Part No.	Description	Destinations	Class	QTY	Standard parts
1	9384 1000 51	WIRING SADDLE	B,C,D1,D3,E,F1,F2,G1,G2,H,I ,K	D	3	
1	9384 1000 51	WIRING SADDLE	J	D	4	
2	9384 1310 91	WIRING SADDLE 18.5H		D	16	
3	9384 1921 11	WIRING SADDLE 9.2H	J	D	16	
3	9384 1921 11	WIRING SADDLE 9.2H	B,C,D1,D3,E,F1,F2,G1,G2,H,I ,K	D	17	
4	9384 1100 91	WIRING SADDLE	B,H,J,F1,G2	D	17	
4	9384 1100 91	WIRING SADDLE	C,D1,D3,E,F2,G1,I,K	D	18	
4	9384 1100 91	WIRING SADDLE	B,C,D1,D3,E,F1,F2,G1,G2,H,I ,K	D	20	
5	9384 1900 54	WIRING SADDLE 23.0H		D	1	
6	9384 1911 11	SO CLIP		D	6	
7	1053 4812 01	CORD CLAMP		D	2	
8	1038 4006 01	INSULATING MEMBER		D	1	
9	9384 2010 21	EDGE COVER 8.5H	J	D	7	
9	9384 2010 21	EDGE COVER 8.5H	B,C,H	D	8	
9	9384 2010 21	EDGE COVER 8.5H	D1,D3,E,F1,F2,G1,G2,I,K	D	9	
10	9384 2910 31	EDGE COVER		D	3	
11	9384 1311 11	CABLE TIE 104L	B,C,D1,D3,E,F1,F2,G1,G2,H,I ,K	D	1	
12	4021 7903 01	JIG		S	2	
13	4021 7904 01	JIG		S	2	
14	4034 7901 01	JIG		S	1	
15	4034 0760 01	POSITIONING PLATE ASSY		S	1	
16	1144 7910 01	JIG TRANSFER ADJUSTING		S	1	
17	9384 1310 81	WIRING SADDLE 6.4H	J	D	2	
18	9J06 M900 00	WIRE SADDLE	J	D	1	
19	9384 2010 21	EDGE COVER 8.5H	J	D	3	

ACCESSORY PARTS

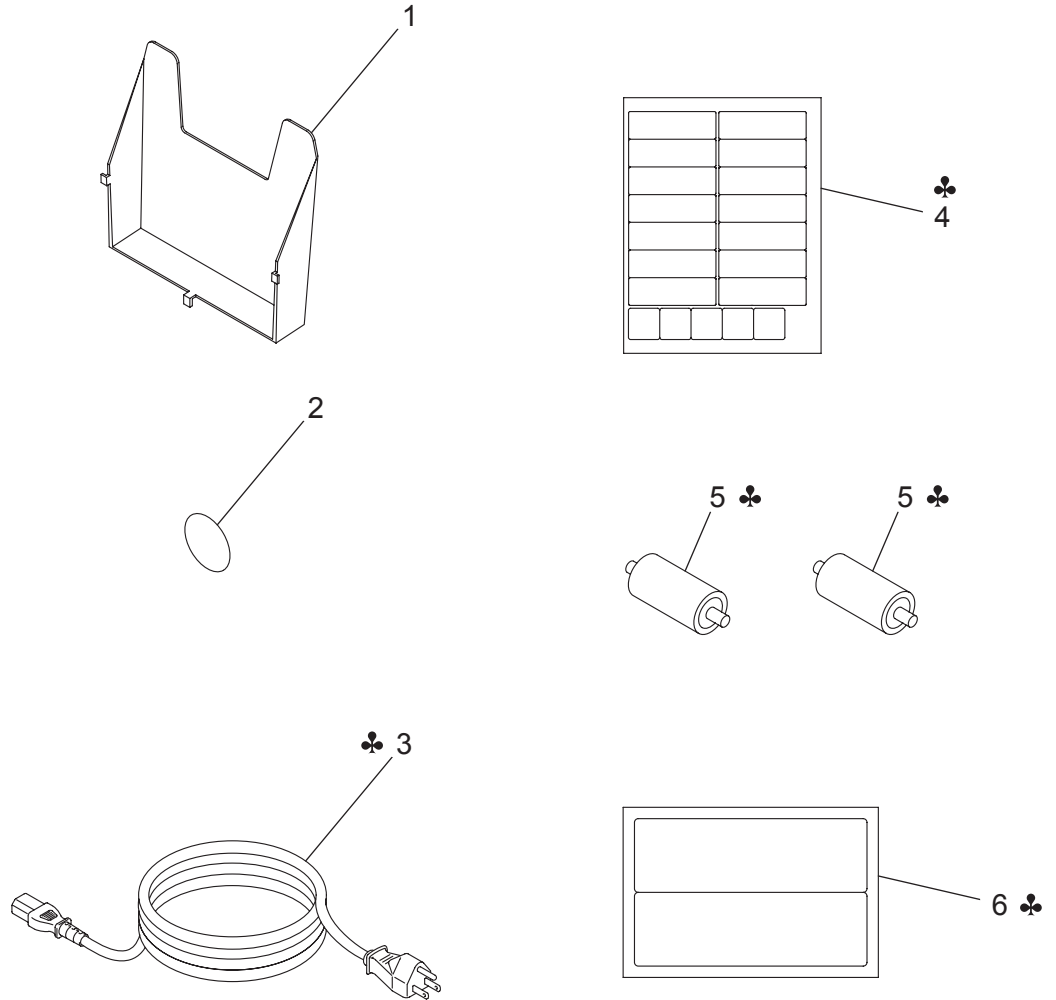

ACCESSORY PARTS

Key	Part No.	Description	Destinations	Class	QTY	Standard parts
1	4034 7507 01	HOLDER		C	1	
2	4034 7603 01	SEAL		C	1	
3	4040 N300 00	POWER CORD /110V	H	D	1	
3	9381 4101 31	POWER CORD	B,G2	C	1	
3	9381 4300 31	POWER CORD	J	D	1	
3	9381 4300 41	POWER CORD	D1,D3,E,F2,G1,I,K	C	1	
4	4011 7313 01	LABEL SIZE METRIC	C,D1,D3,E,F1,F2,G1,G2,H,I,K	C	1	
4	4011 7314 01	LABEL SIZE INCH	B,D1,D3,E,F1,F2,G1,G2,I,K	C	1	
4	4021 7319 01	LABEL SIZE	J	C	1	
5	4687 3262 01	ROLL	J	C	2	
6	4658 7305 01	LABEL PAPER SIZE	J	C	1	

MAINTENANCE LIST

● The items with no Page/Key numbers are not handled as spare parts.

No.	Section	PM Parts Description	Maintenance Cycle (K=1,000)		Parts No.	Destinations	Page/Key	Note
			QTY	Replace				
1	Paper Take-up Section	Feed roller	1	150K	4034301201	-	P22-28	*1
2		Separation roller assy	1	150K	4034015101	-	P22-9	*1
3	Transport Section	Paper dust remover assy	1	40K	4034R70300	-	P9-21	
4	Imaging Unit Section	PC drum	1	40K	-	-	-	
5		Ozone filter	1	150K	1156411802	-	P15-20	
6		PC drum charge corona assy	1	40K	A08ER70200	-	P13-27	
7		Cleaning blade	1	40K	4034562201	-	P15-22	
8		Developer	1	40K	-	-	-	
9		Toner agitating seal	1	40K	A08E370000	-	P14-45	
10	Image Transfer Section	Image transfer roller assy	1	150K	4034R70600	-	P16-18	
11	Fusing Section	Fusing unit	1	150K	4034075100	B,F1,G2	P17-35	
12		Fusing unit	1	150K	4034R70000	D1,D3,E,F2,G1,I,J,K	P17-35	
13		Fusing unit	1	50K	4034R70100	C	P17-35	
14		Fusing unit	1	50K	A08ER70300	H	P17-35	
15	Paper Take-up Section (Paper	Feed roller	2	150K	4686337101	J	P24-23	

*1: Replace those two parts at the same time.

DESTINATION

Destination No.		Destinations		V	Hz	Model No.
A	A1	JAPAN		100	50/60	
	A2	JAPAN		200	50/60	
B		USA, CANADA		120	60	A08E-011
C		EUROPEAN TYPE		220-240	50/60	A08E-021 A08E-022
D	D1	S.E ASIA TYPE	THAILAND, SRI LANKA, SINGAPORE, MALAYSIA, HONG KONG, PAKISTAN, INDIA, BANGLADESH, INDONESIA	220-240	50/60	A08E-041
	D3	OCEANIA TYPE	AUSTRALIA, NEW ZEALAND	220-240	50/60	A08E-041
E		PHILIPPINES		220-240	50/60	A08E-041
F	F1	SAUDI ARABIA		127	60	A08E-0M1
	F2	SAUDI ARABIA		220-240	50/60	A08E-041
G	G1	C.S AMERICA		220-240	50/60	A08E-041 A08E-042
	G2	C.S AMERICA		120	60	A08E-0P1 A08E-0M1
H		TAIWAN		110	60	A08E-071
I		JORDAN, LEBANON, SYRIA, SOUTH AFRICA, IRAQ, IRAN, N.YEMEN, CAMEROON, UAE, BAHRAIN, OMAN, QATAR, KUWAIT, KENYA, TUNISIA, IVORY COAST, MOROCCO		220-240	50/60	A08E-041
J		CHINA		220-240	50/60	A08E-081 A08E-082 A08E-083 A08E-084
K		KOREA		220-240	50/60	A08E-041