

brother[®]

LASER PRINTER

PARTS REFERENCE LIST

MODEL:HL-720/730/730Plus

MECHANISMS & ELECTRONICS

NOTE FOR USING THIS PARTS REFERENCE LIST

1. In the case of ordering parts, it needs mentioning the following items:

- (1) Code
- (2) Q'ty
- (3) Description
- (4) Symbol (PCB No., Revision , and Parts location mounted on the PCB.)

Note : No orders without Parts Code or Tool No. can be accepted.

< Example >

REF.NO.	SYMBOL	CODE	Q'TY	DESCRIPTION	REMARKS

Revision No. : marked on the printed circuit board.

B48K056 - 201A



2. Design-changed parts:

If the parts are changed, any one of the following symbols is indicated in the REMARKS column.

- #A : compatible between old and new
- #B : replaceable from old to new
- #D : incompatible
- # : newly established

3. The original of this list was made based on the information available in March, 1996.

4. Parts are subject to change in design without prior notice.

CONTENTS

PCB SILK-SCREEN PRINTING DRAWING	1
GENERAL DRAWING	2
POWER CORDS & PACKING DRAWING	3
1. FRAME / DRIVE	4
2. SCANNER	4
3. PAPER TRAY	5
4. FIXING UNIT	5
5. CABINET	6
6. MAIN PCB	7
7. PANEL / SENSOR PCB	7
8. LOW-VOLTAGE POWER SUPPLY UNIT	8
9. HIGH-VOLTAGE POWER SUPPLY UNIT	8
10. POWER CORDS	9
11. PACKING	9-1
12. DOCUMENTS	10
13. ADJUSTING TOOL KIT	11

Fig.1 MAIN PCB (HL-720)

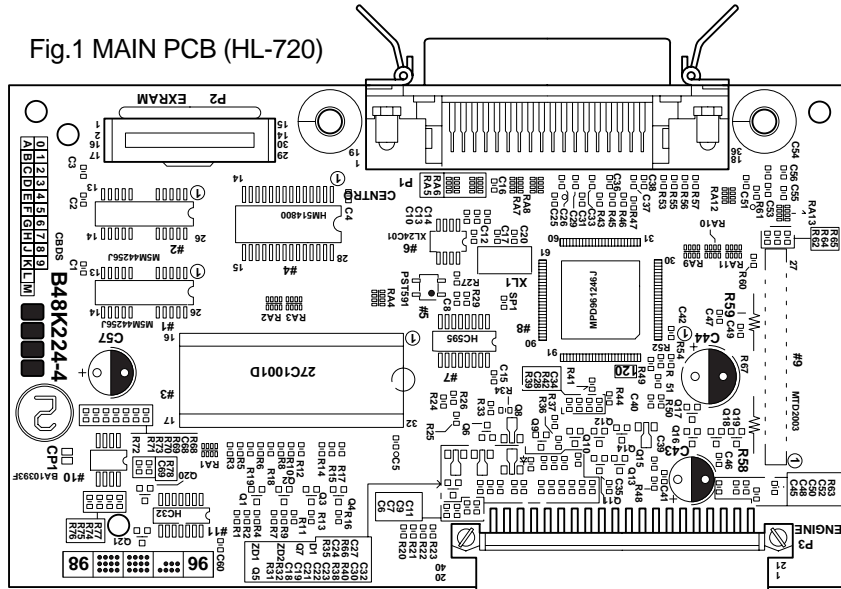
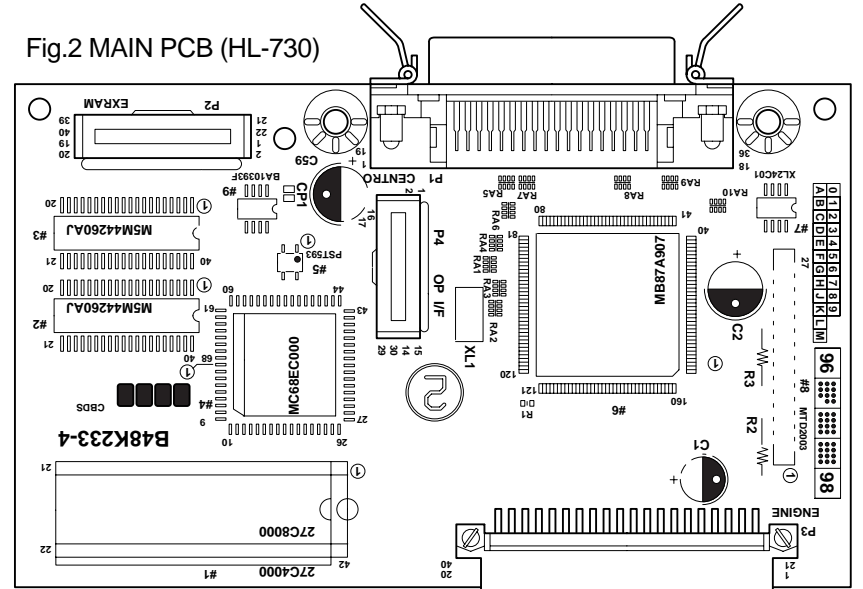
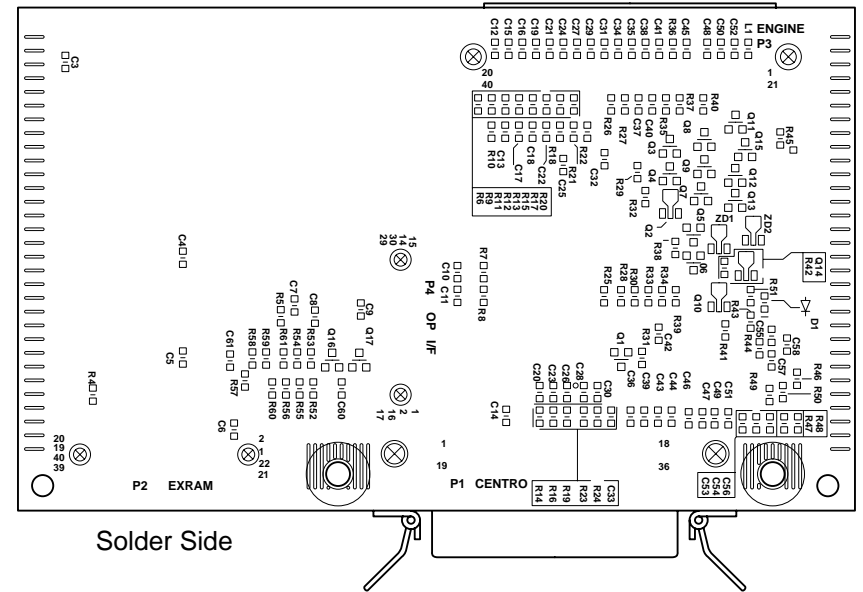
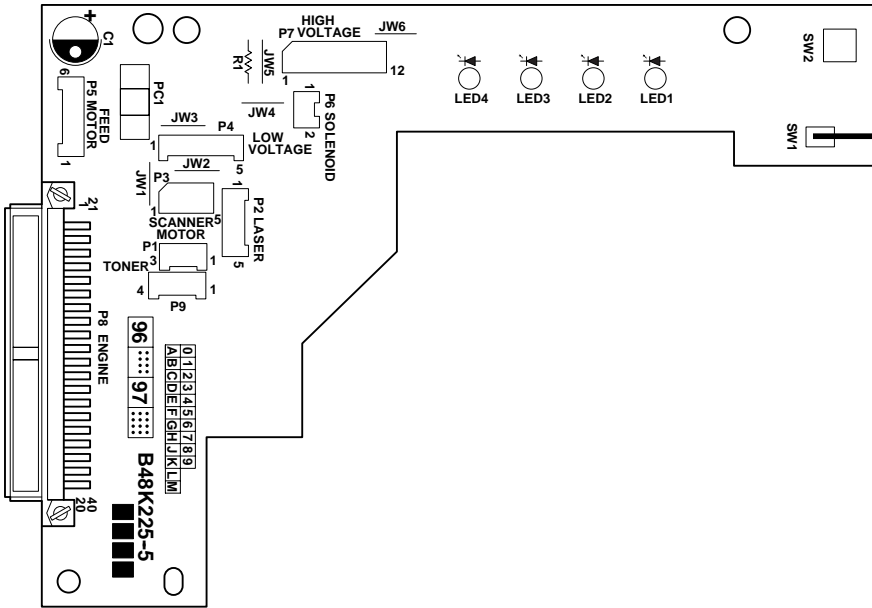

Fig.2 MAIN PCB (HL-730)



Component Side

Fig.3 PANEL/SENSOR PCB (HL-720/HL-730)







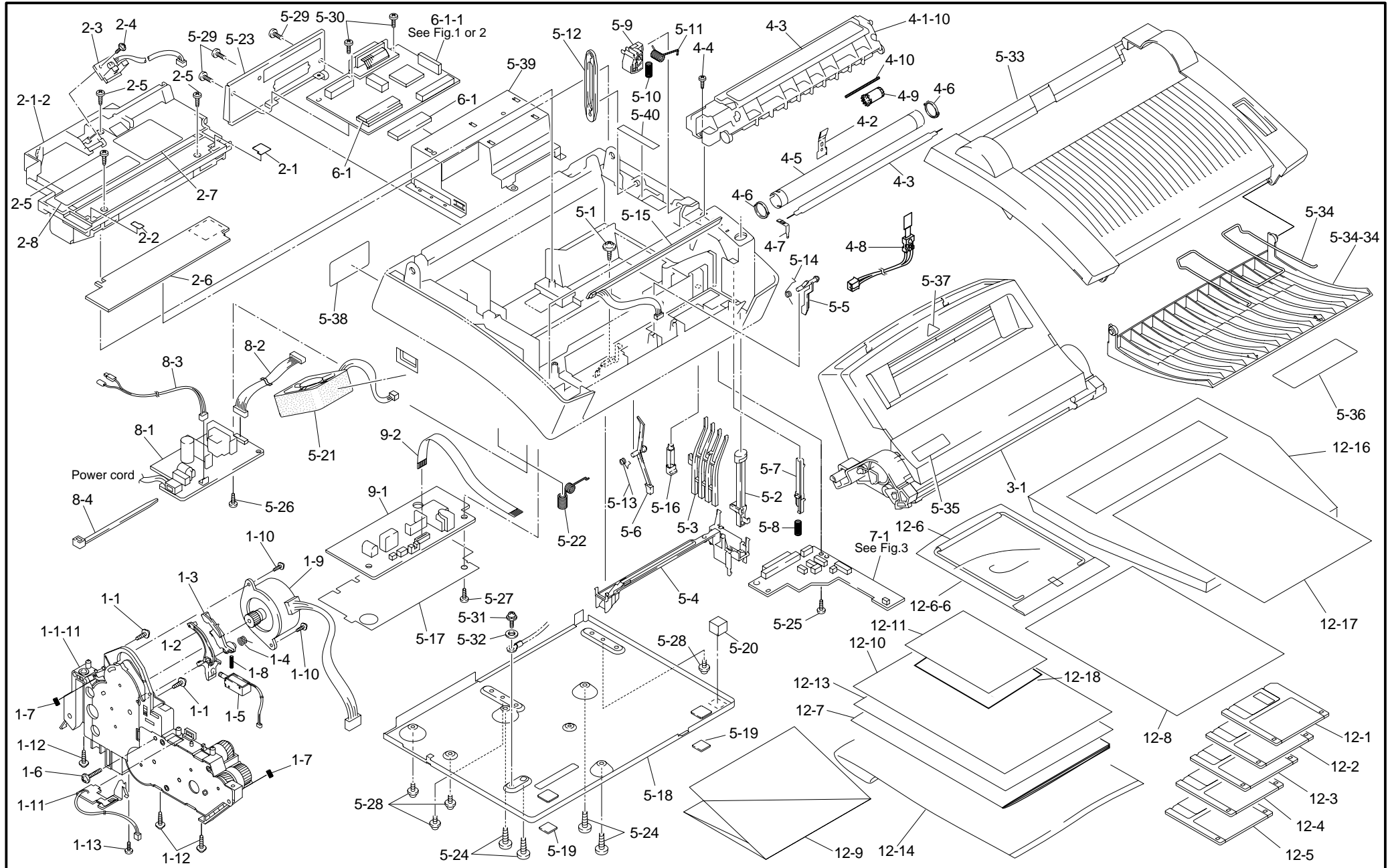

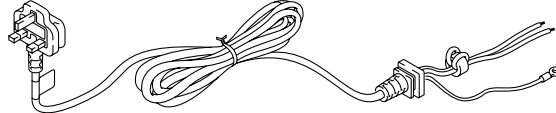

Solder Side

GENERAL DRAWING

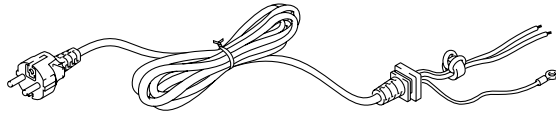

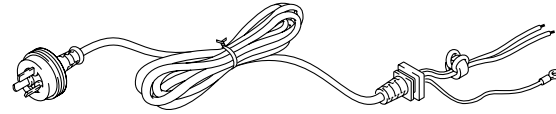
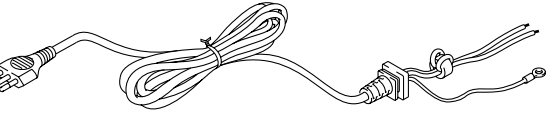
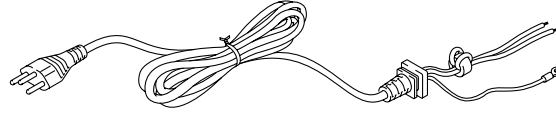
POWER CORDS & PACKING DRAWING

10-			
1A		1F	
1B		1G	
1C		1H	
1D		1I	
1E		1J	

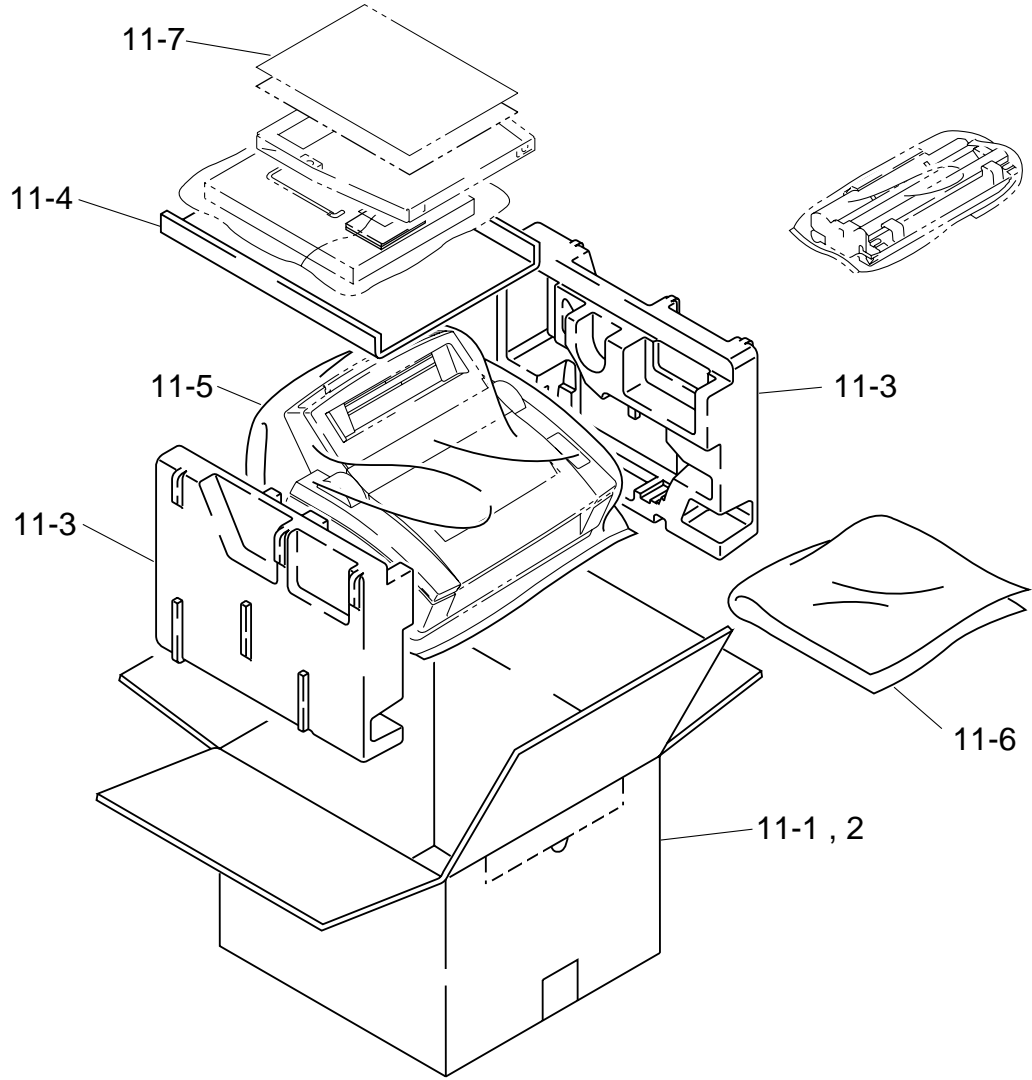

1. FRAME / DRIVE

REF.NO.	SYMBOL	CODE	Q'TY	DESCRIPTION	REMARK
1-11		UL6997001	1	DRIVE UNIT (SP)	
1		087411615	2	TAPTITE, CUP B M4X16	
2		UL6573000	1	PAPER PICK-UP SOLENOID LEVER	
3		UL6574000	1	CLUTCH RELEASE LEVER	
4		UL6575001	1	SOLENOID LEVER RETURN SPRING	
5		UL6576001	1	PAPER PICK-UP SOLENOID ASSY	
6		087322015	1	TAPTITE, CUP S M3X20	
7		UL6577001	2	CLUTCH GEAR SPRING	
8		UL6579001	1	CLUTCH HOLDER SPRING	
9		UL6578001	1	MAIN MOTOR ASSY	
10		087320616	2	TAPTITE, CUP S M3X6	
11	B48K230-3	UK3125001	1	DRUM GROUND PCB ASSY	
12		087412016	3	TAPTITE, CUP B M4X20	
13		085411215	1	TAPTITE, BIND B M4X12	

MODEL HL-720/730 84U-501/601-010

TI NO.96-P021 / 96-P024 / 96-P036

2. SCANNER

REF.NO.	SYMBOL	CODE	Q'TY	DESCRIPTION	REMARK
1-2		UL6875001	1	SCANNER UNIT (SP)	
1		UL6614001	1	S SHEET 1	
2		UL6615001	1	S SHEET 2	
3	B48K231-5	UK3073001	1	TONER SENSOR PCB ASSY	
4		087310815	1	TAPTITE, CUP B M3X8	
5		085411215	3	TAPTITE, BIND B M4X12	
6		UL6611001	1	S SEAL SPONGE 1	
7		UL6740001	1	LASER CAUTION LABEL, EUR	
7		UL7931001	1	LASER CAUTION LABEL, LEGEND	
8		UL6741001	1	CAUTION LABEL, TONER	

MODEL HL-720/730 84U-501/601-020

T/I No. 96-P019 / 96-P036 / 97-P014 / 97-P045 / 97-P072

3. PAPER TRAY

REF.NO.	CODE	Q'TY	DESCRIPTION	REMARK
1	UL6876001	1	MP TRAY ASSY (SP), GRAY1227	

MODEL HL-720/730 84U-501/601-040

4. FIXING UNIT

REF.NO.	CODE	Q'TY	DESCRIPTION	REMARK
1-10	UL6877001	1	FIXING UNIT, 120V (SP)	
1-10	UL6878001	1	FIXING UNIT, 240V (SP)	
1-10	UU7442001	1	FIXING UNIT, 240V PFA (SP)	
1-10	UL7934001	1	FIXING UNIT, 240V LEGEND (SP)	
1	UL6879001	1	FU LAMP, 120V (SP)	
1	UL6880001	1	FU LAMP, 240V (SP)	
2	UL6616001	1	CLEANER ASSY	
3	UL6688001	1	CAUTION LABEL	
3	UL7928001	1	CAUTION LABEL, LEGEND	
4	085411215	1	TAPTITE, BIND B M4X12	
5	UL0984001	1	HEAT ROLLER ASSY (SP)	
5	UL8495001	1	HEAT ROLLER ASSY, PFA (SP)	
6	UL6673001	1	H/R BEARING	
7	UL6677000	1	ELECTRODE PLATE	
8	UL6667001	1	THERMISTOR ASSY	
9	UL6681001	4	EJECT PINCH ROLLER ASSY	
10	UL6682001	4	PINCH SPRING	

MODEL HL-720/730 84U-501/601-050/051/053

TI NO. 96-P056 / 97-P072 / PR97028 / PR97032 / PR98271 / PR98292 / PR99076

5. CABINET

REF.NO.	SYMBOL	CODE	Q'TY	DESCRIPTION	REMARK
1		087310815	6	TAPTITE, CUP B M3X8	
2		UL6714001	1	SW KEY, GRAY1227	
3		UL6715001	1	PANEL LIGT GUIDE	
4		UL6716001	1	DUCT LID	
5		UL6936001	1	PAPER EJECT ACTUATOR ASSY, BLACK	
6		UL6935001	1	REGIST SENSOR ACTUATOR ASSY, BLACK	
7		UL6719000	1	INTERLOCK LEVER	
8		UL6720001	1	SPRING, COMPRESSION	
9		UL6721000	1	LOCK LEVER	
10		UL6722001	1	SPRING, COMPRESSION	
11		UL6723001	1	PR LOCK SPRING	
12		UL6729000	1	TOP COVER LINK	
13		UL6930001	1	SPRING, TORSION	
14		UL6931001	1	SPRING, TORSION EX	
15	B48K228-2	UL6887001	1	EL PCB UNIT	
16		UL6853001	1	DENSITY DIAL, GRAY1252	
17		UL6725000	1	INSULATION SHEET	
18		UL6728000	1	BASE PLATE	
19		UL5600001	2	RUBBER FOOT	
20		UL6864001	1	PCB SUPPORT	
21		UL6934001	1	FAN MOTOR ASSY	
22		UL6973000	1	DRUM GROUND SPRING	
23		UL6731001	1	I/F SHIELD ASSY	
24		085411215	4	TAPTITE, BIND B M4X12	
25		085411215	1	TAPTITE, BIND B M4X12	
26		085411215	1	TAPTITE, BIND B M4X12	
27		085411215	1	TAPTITE, BIND B M4X12	
28		087320616	4	TAPTITE, CUP S M3X6	
29		002400616	3	SCREW, PAN M4X6	
30		087320616	2	TAPTITE, CUP S M3X6	
31		UL6915001	1	SCREW, PAN (WASHER) M4X6	
32		025040235	1	WASHER, PLAIN M 4	
33		UL6703001	1	TOP COVER, GRAY1227	
34-34		UL6735001	1	PAPER EJECT TRAY ASSY, GRAY1227	
34		UL6736001	1	PAPER EJECT TRAY EXTENSION	
35		UL6581001	1	MODEL PLATE, HL-720 USA/CAN	
35		UL6944001	1	MODEL PLATE, HL-720 EUR	
35		UL7935001	1	MODEL PLATE, HL-720 LEGEND	
35		UL6737001	1	MODEL PLATE, HL-730 USA/CAN	
35		UL7530001	1	MODEL PLATE, HL-730DX USA/CAN	
35		UL6945001	1	MODEL PLATE, HL-730 EUR	
35		UL7549001	1	MODEL PLATE, HL-730 LEGEND	
35		UL7763001	1	MODEL PLATE, HL-730 KOR OEM SSANG YONG	
35		UL7814001	1	MODEL PLATE, HL-730+ USA/CAN	
35		UL7818001	1	MODEL PLATE, HL-730DX+ USA/CAN	
35		UL7815001	1	MODEL PLATE, HL-730+ EUR	
36		UL6580001	1	MYLAR LABEL, USA HL-720	
36		UL6953001	1	MYLAR LABEL, CAN HL-720	
36		UL6743001	1	MYLAR LABEL, USA HL-730	
36		UL7531001	1	MYLAR LABEL, USA HL-730DX	
36		UL6954001	1	MYLAR LABEL, CAN HL-730/730DX	
36		UL7819001	1	MYLAR LABEL, USA HL-730+	
36		UL7821001	1	MYLAR LABEL, USA HL-730DX+	
36		UL7820001	1	MYLAR LABEL, CAN HL-730+/730DX+	
37		UL5738001	1	PAPER SET LABEL, USA/CAN	
38		UH0905001	1	PATENT LABEL, USA/CSA HL-730/730DX	
39		UL6724000	1	MAIN SHIELD	
40		UL7940001	1	GUIDE FILM	

MODEL HL-720/730 84U-501/601-060

TI NO. 96-P012 / 96-P014 / 96-P015 / 96-P026 / 96-P076 / 97-P016 / 97-P060 / 97-P068 / 97-P076 / PR97040

6. MAIN PCB

REF.NO.	SYMBOL	CODE	Q'TY	DESCRIPTION	REMARK
1-1	B48K224-410	UK3593001	1	MAIN PCB ASSY W (SP), HL-720	
1-1	B48K224-420	UK3730001	1	MAIN PCB ASSY W (SP), LEGEND HL-720	
1-1	B48K233-410A	UK3594001	1	MAIN PCB ASSY P (SP), HL-730/730DX	
1-1	B48K233-411A	UK3597001	1	MAIN PCB ASSY P (SP), HEB HL-730	
1-1	B48K233-420	UK3703001	1	MAIN PCB ASSY 1M (SP), HL-730+/730DX+	
1-1	B48K233-421A	UK3704001	1	MAIN PCB ASSY 1M (SP) HEB, HL-730+	
1	#1	UK3671001	1	MASK ROM:KM23C4100C HL-730/730+	
1	#1	UK3551001	1	PROM:HL730HEB ASSY, HL-730/730+	

MODEL HL-720/730 84U-501/601-102/101/104/105/106

TI NO.96-P012 / 96-P024 / 96-P036 / 96-P062 / 97-P015 / 97-P016 / 97-P076 / PR98042

7. PANEL / SENSOR PCB

REF.NO.	SYMBOL	CODE	Q'TY	DESCRIPTION	REMARK
1	B48K225-500C	UK3189001	1	PANEL/SENSOR PCB ASSY (SP)	

MODEL HL-720/730 84U-501/601-151

T/I No. 96-P036

8. LOW-VOLTAGE POWER SUPPLY UNIT

REF.NO.	SYMBOL	CODE	Q'TY	DESCRIPTION	REMARK
1	REV.A	UK3190001	1	PS PCB ASSY, 115V (SP)	
1	REV.A	UK3191001	1	PS PCB ASSY, 230V (SP)	
2		UK3061001	1	LV HARNESS ASSY	
3		UK3062001	1	HEATER HARNESS ASSY	
4		J02101051	1	BINDER 2.3X79	

MODEL HL-720/730 84U-501/601-200/201

TI NO.96-P072

9. HIGH-VOLTAGE POWER SUPPLY UNIT

REF.NO.	SYMBOL	CODE	Q'TY	DESCRIPTION	REMARK
1		UK3192001	1	HIGH-VOLTAGE PS PCB ASSY (SP)	
2		UK3059000	1	HV FLAT CABLE 12	

MODEL HL-720/730 84U-501/601-220

10. POWER CORDS

REF.NO.	CODE	Q'TY	DESCRIPTION	REMARK
1A	UK3135001	1	AC CORD ASSY, USA	
1B	UK3138001	1	AC CORD ASSY, UK	
1C	UK3141001	1	AC CORD ASSY, EUR	
1D	UK3144001	1	AC CORD ASSY, SAA	
1E	UK3147001	1	AC CORD ASSY, SEV	
1F	UK3971001	1	AC CORD ASSY, DEMKO	
1G	UK3151001	1	AC CORD ASSY, HEB	
1H	UK3152001	1	AC CORD ASSY, S.AF	
1I	UK3217001	1	AC CORD ASSY, CHLI	
1J	UK3831001	1	AC CORD ASSY, CHN	

MODEL HL-720/730 84U-501/601-230

TI NO. 96-P012 / 96-P051 / 97-P044 / PR97146 / PR98037

11. PACKING

REF.NO.	CODE	Q'TY	DESCRIPTION	REMARK
1	UE2093001	1	CARTON, EUR HL-720	
1	UE2085001	1	CARTON, EUR HL-730	
1	UE2216001	1	CARTON, LEGEND HL-720	
1	UE2171001	1	CARTON, LEGEND HL-730 (LJ6P)	
1	UE2121001	1	CARTON ASSY, USA/CAN HL-720 (WITH 2, LABEL)	
1	UE2122001	1	CARTON ASSY, USA/CAN HL-730 (WITH 2, LABEL)	
1	UE2123001	1	CARTON ASSY, USA/CAN HL-730DX (WITH 2, LABEL)	
1	UE2151001	1	CARTON, GULF HL-730	
1	UE2186001	1	CARTON, KOR OEM SSANG YONG	
1	UE2204001	1	CARTON, NO BRAND +	
1	UE2200001	1	CARTON, EUR HL-730+	
1	UE2199001	1	CARTON, USA/CAN HL-730+	
1	UE2202001	1	CARTON, USA/CAN HL-730DX+	
1	UE2201001	1	CARTON, GULF HL-730+	
1	UE2203001	1	CARTON, LEGEND HL-730+	
1	UE2205001	1	CARTON, KOR OEM SSANG YONG+	
2	UE2124001	1	CARTON, USA/CAN	
3	UE2086000	1	STYROFORM PAD ASSY	
4	UE2107000	1	CARTON, SF ASSY	
5	UE2126001	1	BAG, 700X800H (BODY)	
6	UE2108001	1	SHEET, 200X300 (BODY)	
7	UH3373001	1	NO RETURN FORM, US	
7	UH3295001	1	RETURN FORM CANADA	

MODEL HL-720/730 84U-501/601-930

TI NO. 96-P012/96-P014/96-P019/96-P026/96-P030/96-P051/96-P076/97-P016/97-P026/97-P060/97-P076
/PR97158/PR98031/PR98036

12. DOCUMENTS

REF.NO.	CODE	Q'TY	DESCRIPTION	REMARK
1	UK3181001	1	PR DRIVER DISK ASSY 1, WINDOWS HL-720	
1	UK3726001	1	PR DRIVER DISK ASSY 1, WINDOWS LEGEND HL-720	
1	UK3155001	1	PR DRIVER DISK ASSY 1, WINDOWS HL-730/730DX	
1	UK3243001	1	PR DRIVER DISK ASSY 1, WINDOWS LEGEND HL-730	
1	UK3566001	1	PR DRIVER DISK ASSY 1, WINDOWS ISR HL-730	
1	UK3571001	1	PR DRIVER DISK ASSY 1, WINDOWS KOR HL-730	
1	UK3636001	1	PR DRIVER DISK ASSY 1, WINDOWS KOR OEM SSANG YONG	
1	UK3672001	1	PR DRIVER DISK ASSY 1, WINDOWS HL-730+/730DX+	
1	UK3688001	1	PR DRIVER DISK ASSY 1, WINDOWS ISR HL-730+	
2	UK3183001	1	PR DRIVER DISK ASSY 2, FONT&DOS HL-720	
2	UK3728001	1	PR DRIVER DISK ASSY 2, FONT&DOS LEGEND HL-720	
2	UK3157001	1	PR DRIVER DISK ASSY 2, FONT&DOS HL-730/730DX	
2	UK3245001	1	PR DRIVER DISK ASSY 2, FONT&DOS LEGEND HL-730	
2	UK3568001	1	PR DRIVER DISK ASSY 2, FONT&DOS ISR HL-730	
2	UK3573001	1	PR DRIVER DISK ASSY 2, FONT&DOS KOR HL-730	
2	UK3638001	1	PR DRIVER DISK ASSY 2, FONT&DOS KOR OEM SSANG YONG	
2	UK3674001	1	PR DRIVER DISK ASSY 2, FONT&DOS HL-730+/730DX+	
2	UK3690001	1	PR DRIVER DISK ASSY 2, FONT&DOS ISR HL-730+	
3	UK3159001	1	PR DRIVER DISK ASSY 3, PCL5 USA/CAN HL-730/730DX	
4	UK3676001	1	PR DRIVER DISK ASSY 3, INTERNET HL-730+/730DX+	
4	UK3714001	1	PR DRIVER DISK ASSY 5, NT4.0 CANADA	
5	UK3686001	1	PR DRIVER DISK ASSY 4, PCL5E USA/CAN HL-730+/730DX+	
5	UK3732001	1	PR DRIVER DISK ASSY 6, ARABIC	
6-6	UE2188001	1	TRAY EXTENSION BAG ASSY	
6	UL7158001	1	TE TUBE	
7	UL6857001	1	USER'S MANUAL, USA HL-720/730/730DX	
7	UL7510001	1	USER'S MANUAL, FRA HL-720/730	
7	UL6862001	1	USER'S MANUAL, GER HL-720/730	
7	UL7511001	1	USER'S MANUAL, NOR HL-720/730	
7	UL7512001	1	USER'S MANUAL, NLD HL-720/730	
7	UL6951001	1	USER'S MANUAL, ITA HL-720/730	
7	UL7513001	1	USER'S MANUAL, SWE HL-720/730	
7	UL7495001	1	USER'S MANUAL, DEN HL-720/730	
7	UL7055001	1	USER'S MANUAL, KOR HL-720/730	
7	UL7765001	1	USER'S MANUAL, KOR OEM SSANG YONG	
8	UL6858001	1	SET GUIDE, USA HL-720/730/730DX	
8	UL7514001	1	SET GUIDE, FRA HL-720/730	
8	UL6863001	1	SET GUIDE, GER HL-720/730	
8	UL7515001	1	SET GUIDE, NOR HL-720/730	
8	UL7516001	1	SET GUIDE, NLD HL-720/730	
8	UL6952001	1	SET GUIDE, ITA HL-720/730	
8	UL7517001	1	SET GUIDE, SWE HL-720/730	
8	UL7496001	1	SET GUIDE, DEN HL-720/730	
8	UL7056001	1	SET GUIDE, KOR HL-720/730	
8	UL7775001	1	SET GUIDE, KOR OEM SSANG YONG	
9	UL6859001	1	WARRANTY CARD, USA	
9	UH2693001	1	WARRANTY CARD, CAN	
9	UL7484001	1	WARRANTY CARD 2, CAN HL-730DX	
9	UL7581001	1	WARRANTY CARD, FRA2	
9	237703001	1	WARRANTY CARD, DUTCH	
10	UL7426001	1	SC INSERTION SHEET, USA	
11	UL6868001	1	ACCESSORY ORDER F, USA HL-720	
11	UL6860001	1	ACCESSORY ORDER F, USA HL-730/730DX	
11	UL7865001	1	ACCESSORY ORDER F, USA HL-730+	
11	UH3294001	1	ACCESSORY ORDER F, CANADA	
13	UL7538001	1	PCL5E INSERTION, USA/CAN HL-730/730DX	
14	UE2014001	1	BAG, 215X350H	
16	UL6955001	1	DUST COVER	

REF.NO.	CODE	QTY	DESCRIPTION	REMARK
17	UL6996001	1	INSERTION DC	
18	UL7916001	1	HL-730+ INSERTION SHEET CHN	

MODEL HL-720/730 84U-501/601-920

TI NO. 96-P014/96-P019/96-P020/96-P030/96-P037/96-P038/96-P040/96-P45/96-P052/96-P058/96-P065
/96-P076/97-P006/97-P007/97-P016/97-P017/97-P018/97-P050/97-P061/97-P069/97-P070/97-P076
/97-P077/97-P080/PR97036/PR98035

13 . ADJUSTING TOOL KIT

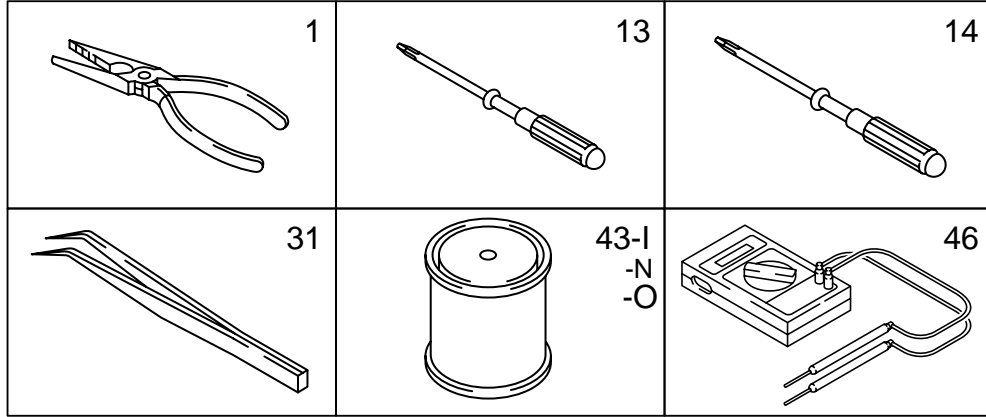

TOOL NO.	TOOL NAME
ZX-1	PLIERS (150MM)
ZX-13	SCREWDRIVER, PHILLIPS (NO-1)
ZX-14	SCREWDRIVER, PHILLIPS (NO-2)
ZX-31	TWEEZERS (150MM)
ZX-43I	LUBRICATING GREASE (FLOIL GE-676)
ZX-43N	LUBRICATING GREASE(MOLYKOTE EM-30L TKC-0)1KG
ZX-43O	LUBRICATING GREASE(MOLYKOTE EM-D110) 1KG
ZX-46	TESTER (MD-200C)