

LICENSE AGREEMENT

Static Control Components, Inc. (Static Control) grants this limited license to the person, firm or corporation (hereinafter "User") downloading electronically or by printing this file to use Static Control's copyrighted documents in accordance with the terms of this agreement. If you agree with the terms of the license then you may download this information. If you do not agree with the terms of the license, then you are not authorized to use this information, and any use of it may be in violation of Static Control's copyrights or trademarks.

TRADEMARKS

The Static Control material herein may make reference to its own trademarks, or trademarks of others. Static Control grants a limited license to the User to use Static Control's trademarks in its internal documents and for its internal purposes on the following terms and conditions. Any use of Static Control's trademark must be used in a context which makes it clear that the product reference is a Static Control Components, Inc. product, and not a product from any source. The materials provided to the User may include reference to trademarks of others. Any use of the User makes of these marks should reference the owner of those marks. Nothing in this agreement constitutes any authorization by Static Control to use any of these trademarks in any context.

COPYRIGHTS

Static Control grants a limited license to the User to use the attached copyrighted documents. The permitted use of these documents is limited to internal purposes and needs of the company. The company is prohibited from using these copyrighted documents, or any part of them, including graphic elements, in any materials that are used outside the physical business location of the User. The User is prohibited from using any materials in any documents whether printed or electronic, which are distributed to any third party. The use of these copyrighted documents, or parts of them, including graphic elements, from these documents in marketing material, either print, electronic or web is prohibited. The sale, transfer, copying of these documents or any parts of these documents to any other party is prohibited.

Static Control Components, Inc. retains all rights to its copyrighted documents, and any use of these documents by User should reference Static Control's copyrights, with the notice "copyright Static Control Components, Inc."

Static Control reserves the right to cancel this license on 30-days written notice. All of the User's material incorporating Static Control's copyrighted documents shall be destroyed upon receipt of its notice of termination.

The User may not distribute, share, and otherwise convey the copyrighted documents to any other persons, corporations or individuals.

The User, by use of these documents, acknowledges Static Control's copyright in these materials.

STATIC CONTROL DOES NOT GUARANTEE OR WARRANT DOWNLOADED INFORMATION

The information User is downloading is published by Static Control in "as is" condition "with all faults". Static Control makes no representations or warranties of any kind concerning the quality, safety, or suitability of the downloadable materials, either express or implied, including without limitation any implied warranties of merchantability, fitness for a particular purpose, or non-infringement. Further, Static Control makes no representations or warranties as to the truth, accuracy or completeness of any statements, information or materials concerning items available for download. In no event will Static Control be liable for any indirect, punitive, special, incidental, or consequential damages however they may arise even if Static Control has been previously advised of the possibility of such damages.



Brother HL® 5140/5150/5170 Remanufacturing Instructions

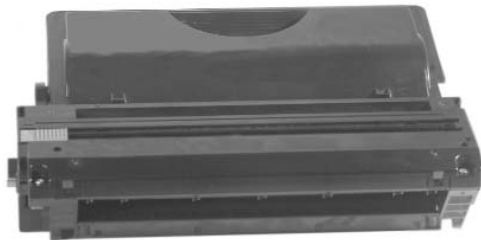

About the Printer

In February of 2004 Brother releases the HL-5140/5150/5170. Reasonably priced with a duty cycle of 20k pages per month. The first page out for these printers is less than 10 seconds. The HL-1240/1650 printers print 21 pages per minute. The OEM rated page yield ranges from 3.5k to 6.7 k.

The Brother HL-5140/5150/5170 cartridges are sold in two separate sections. There is a Hopper section and Drum section which contains a corona wire assembly.

Table of Contents

Introduction1-2
 Tools & Supplies You Will Need . . 2
 Use of Compressed Air 2
 Use of Isopropyl Alcohol 2
 Toner Unit3
 Waste Bin Unit4
 Disassembly Toner Hopper Section
5-6
 Assembly Toner Hopper Section
 7-8
 Disassembly of the Drum Section
 9-10
 Assembly of the Drum Section
11-12

WWW.SCC-INC.COM

Get the latest information on the web at Static Control's Brother® HL 5140 Online Engine Center at www.scc-inc.com

System Support Series™ documents are available on our Web site in Adobe® Acrobat® format.



If you need additional information or technical assistance, please contact your Regional Support Team.

800 488 2426 (USA)
 919.774.3808 (Int'l)
 +44 (0) 118.923.8800 (UK)
info@scc-inc.com (US Email)
info@scceurope.co.uk (UK Email)
www.scc-inc.com

Engine Information

Engine Name	Brother® HL5140/5150/5170		
Printer Price	\$229 /\$299/\$449		
Printer Name	Brother® HL5140/5150/5170		
First Page Out	Less than 10 seconds		
Charger	Corona		
Date of U.S. Printer Introduction	Feb. 2004		
Print Speed (pages per minute)	21 ppm		
Duty Cycle	20,000 pages per month		
Print Resolution (dpi)	2400 x 600 dpi		

Cartridge Information

Part Number (Hopper)	TN-540	TN-3030	TN-3060
Cartridge List Price	\$70	\$92	45
OEM Rated Page Yield	3.5k	6.7k	6.7k
Wholesale Price	\$45	\$59	N/A
Part Number (Drum)	DR-510	DR-3000	
Cartridge List Price	\$180	£82	
OEM Rated Page Yield	20k	20k	
Wholesale Price	\$107	N/A	

*Prices as of Jan. 2005

Use of Compressed Air

As of April 28, 1971, the Occupational Safety & Health Administration (OSHA) Standard, 29 CFR 1910.242 paragraphs a & b for general industry requires effective chip guarding and personal protective equipment (PPE) when using compressed air. When cleaning residual toner particles from cartridges using a compressed air system, you must use air nozzles meeting OSHA requirements. Air nozzles that regulate air pressure to a maximum of 30 psi comply with this standard. Refer to the OSHA publication for any updates or changes that have occurred since the date noted above.

Use of Isopropyl Alcohol

For best results, we recommend using ONLY 91-99% for cleaning as directed in these instructions. 91% Isopropyl alcohol is available at most major drug stores; 99% Isopropyl alcohol is available through distributors of chemical products. Follow the alcohol manufacturer's safety instructions.

Tools and Supplies You Will Need

For Basic Remanufacturing:

- Phillips Screwdriver
- Standard Flat Blade Screwdriver
- Small-Tipped Flat Blade Screwdriver
- Needlenose Pliers
- Funnel for Toner Bottle
- Compressed Air for Cleaning(See left)
- 91-99% Isopropyl Alcohol(See left)
- Lint-Free Foam Tip SwabLFSWAB
- Lint-Free Cleaning ClothLFCCLOTH
- Cotton SwabQTIP
- Aluminum MalletWXHAMMER
- Liquid Cartridge LubricantCLUBE

Brother® HL 5140 Toner Unit

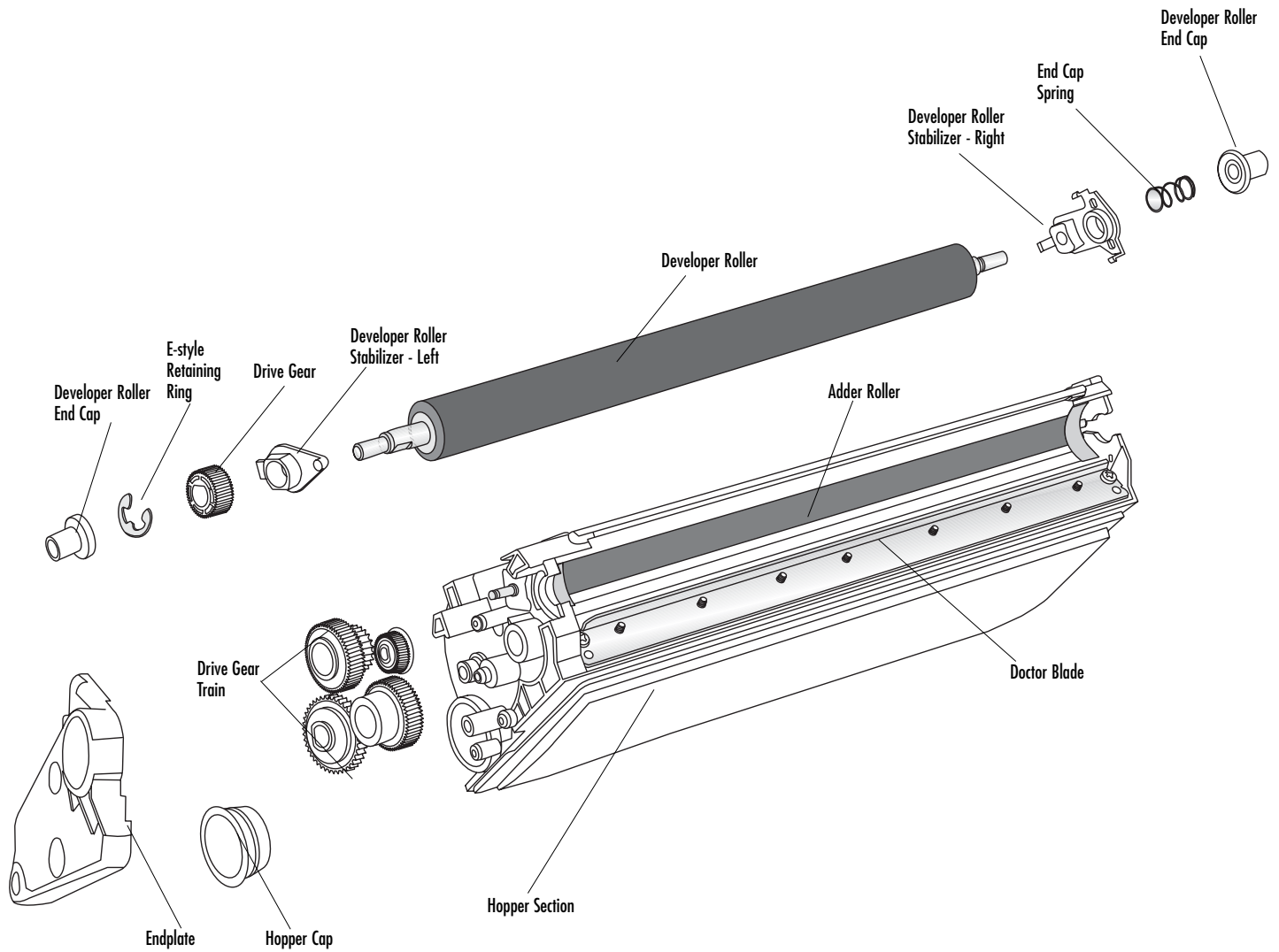

Brother® HL 5140 Waste Bin Unit

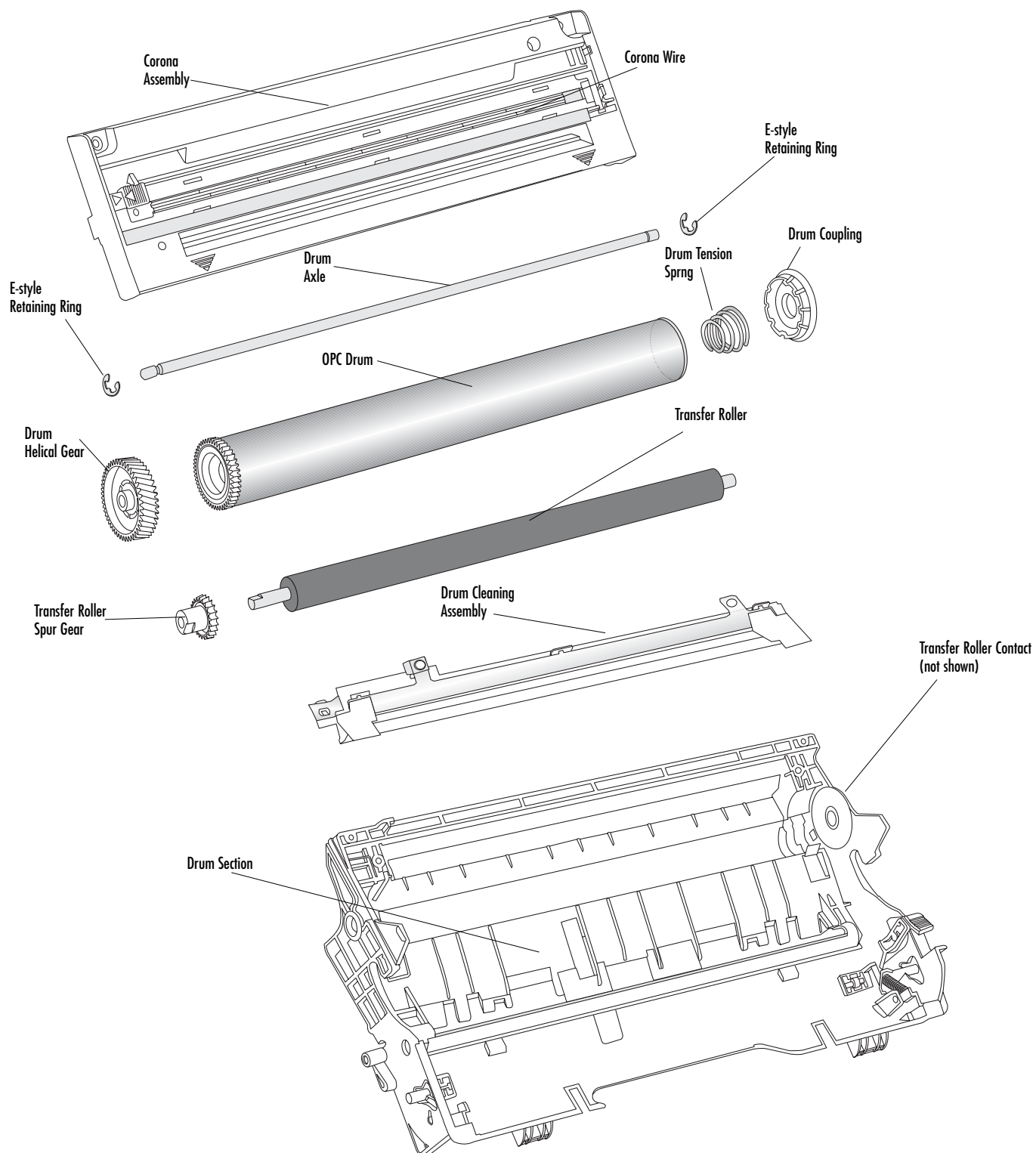

Disassembly of the Toner Hopper Section

1. Remove developer roller end cap from the drive side by sliding it completely off the developer roller shaft (FIG 1).

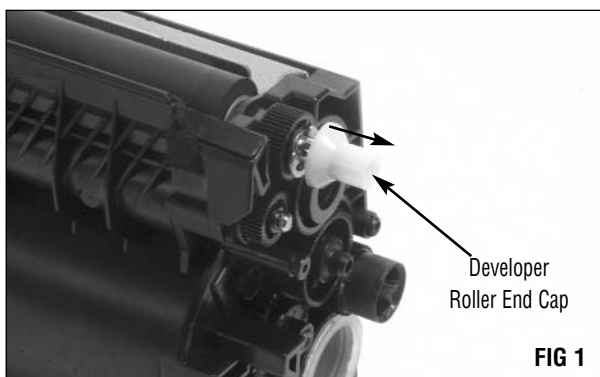

2. Remove the e-style retaining ring from the developer roller (FIG 2).

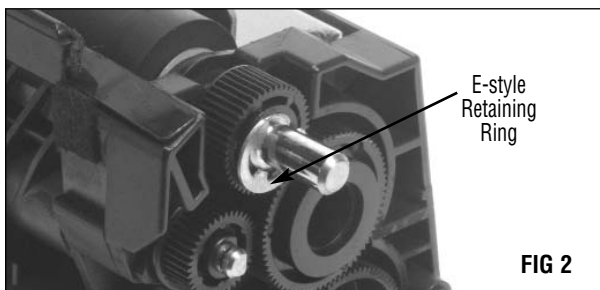

3. Using a flat blade screwdriver, wedge in between the stabilizer and the cartridge in order to pull the tab out as shown (FIG 3). Then rotate the stabilizer toward the top of the cartridge as shown (FIG 4).

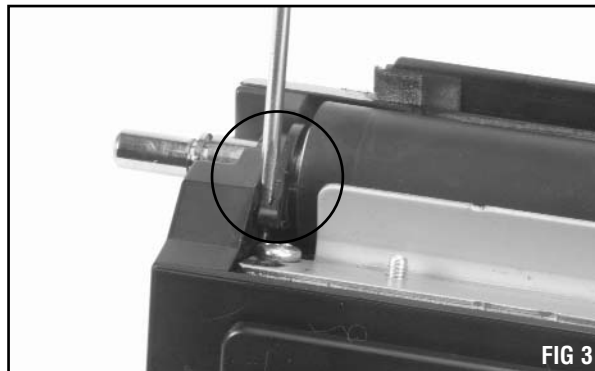

- Using a flat blade screwdriver, remove the developer roller end cap from the non-drive side of the cartridge (FIG 5). Remove the spring once the end cap is removed (FIG 6).

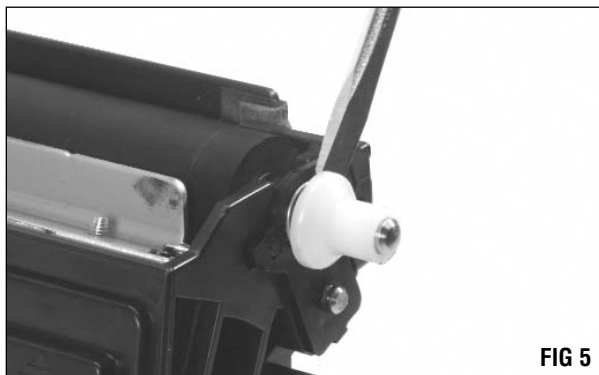

FIG 5



FIG 6

- Using a flat blade screwdriver, remove the stabilizer by releasing the locking clip (FIG 7).

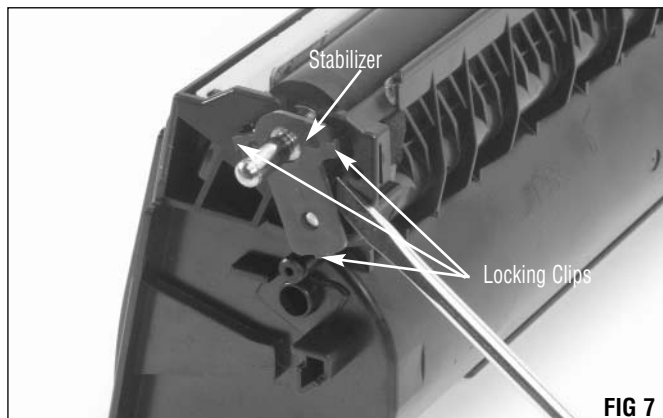

FIG 7

- Carefully remove the developer roller from the cartridge and clean with dry, filtered compressed air and a lint-free cloth, dampened with water (if necessary) (FIG 8). Inspect for damage and replace with SCC's developer roller (B1240DEVROLL) if necessary.

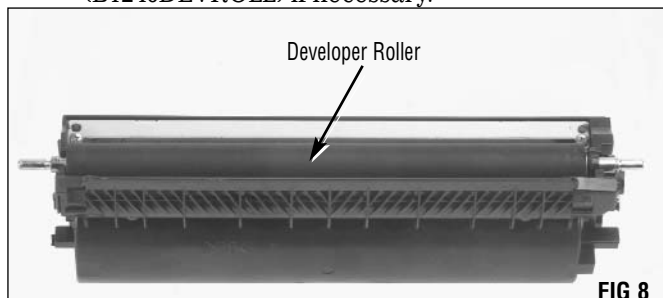

FIG 8

- Remove the hopper cap and dump out any residual toner (FIG 9). Careful not to damage the Hopper Cap.



FIG 9

- Clean the toner hopper section with dry, filtered, compressed air and wipe the doctor blade with a clean, dry cloth (FIG 10).

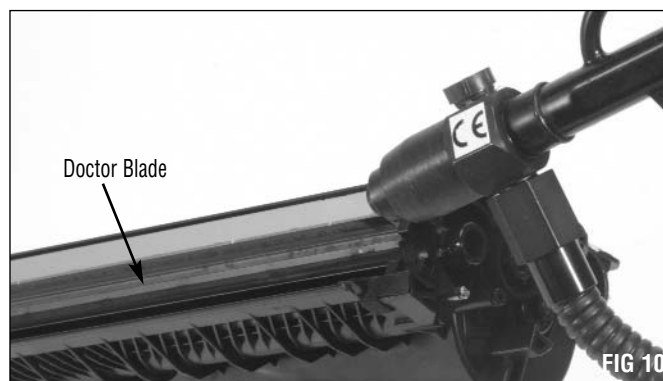
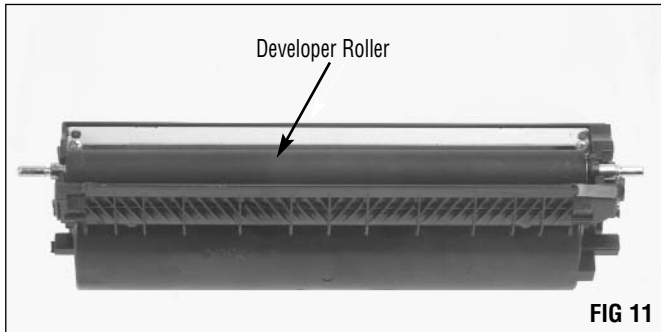

FIG 10

NOTE: See SSS#759 for detailed instructions on the removal and installation of the doctor blade and the sealing foam (B1240DBLADE) (B1240DBSFM).

Assembly of the Toner Hopper Section

1. Replace the developer roller (FIG 11).



2. Turn the stabilizer down until the tab snaps into place as shown (FIG 12 & 13).



3. Replace the stabilizer (FIG 14). Make sure that the locking clips are secure.

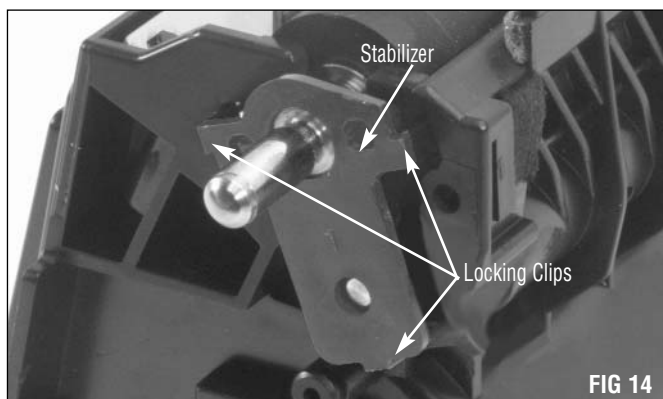

4. Replace the end cap spring (FIG 15). Replace the developer roller end cap to the cartridge (FIG 16).

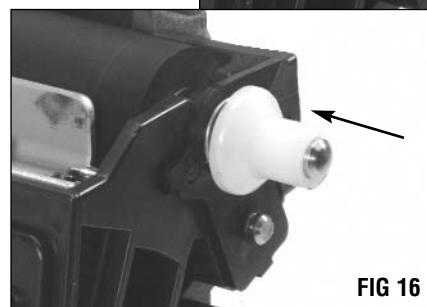
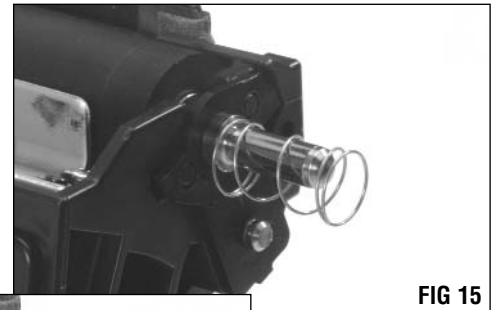

5. Fill the hopper with toner and replace the hopper cap, use SCC's hopper cap (HCAP-A) if damaged (FIG 17).



6. Replace the e-style retaining ring to the developer roller (FIG 19).

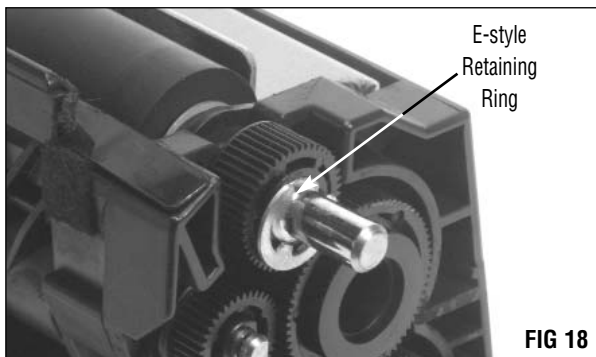

7. Replace the developer roller end cap by sliding it completely on the developer roller shaft (FIG 19).

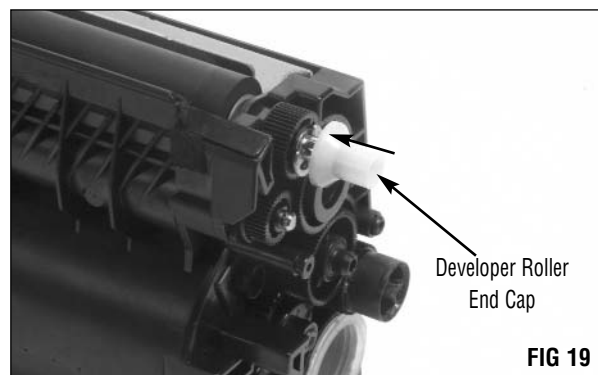

Disassembly of the Drum Section

1. Using a Phillips screwdriver, remove the two screws securing the corona assembly (FIG 20). Then lift out the corona assembly

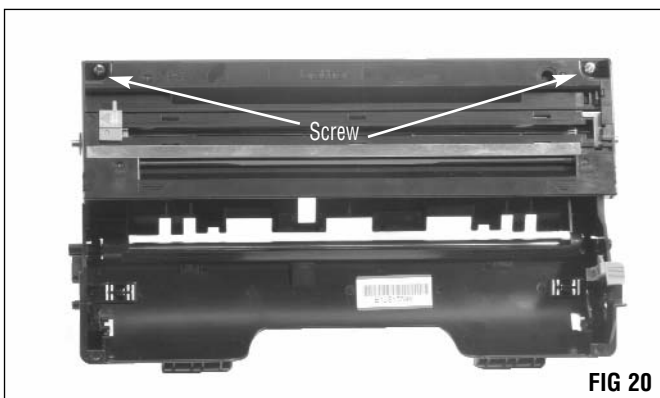

2. Remove assembly and e-style retaining ring from the drum axle (FIG 21).

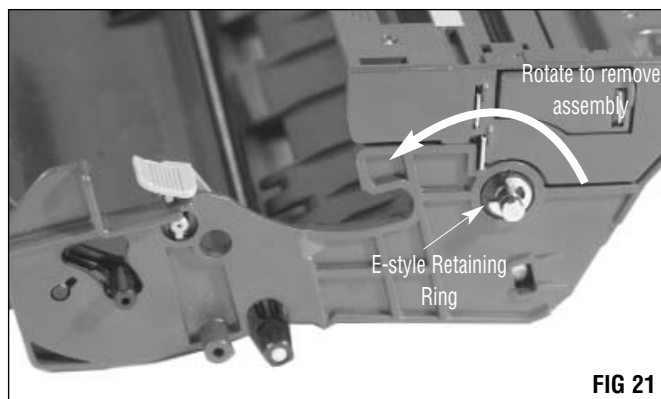

3. Using a Phillips screwdriver, remove the two screws securing drum cleaning assembly (FIG 22).

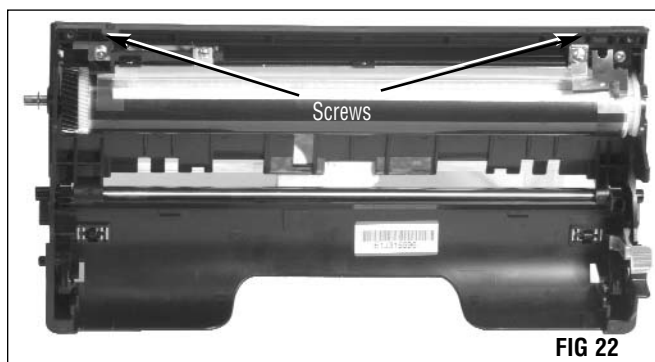

4. Using an aluminum mallet, gently tap out the drum axle and remove the drum axle stabilizer bushing (FIG 23). Pull the drum axle from the other side and remove the drum and gears (FIG 24).

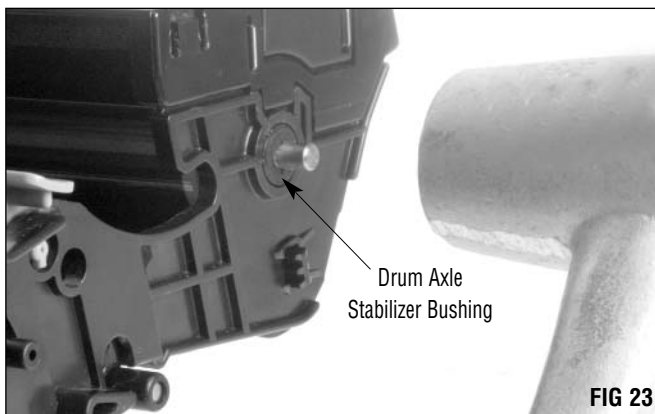

5. Remove the transfer roller (FIG 25). Make sure not to lose the transfer roller gear, the transfer roller contact (FIG 26), or the drum axle stabilizer bushing.

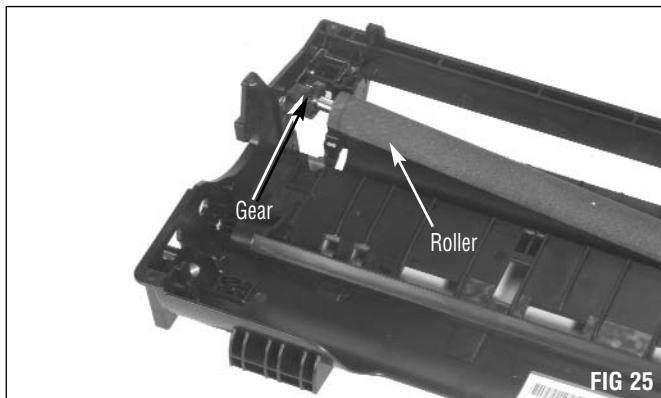

6. Clean the drum section and the corona assembly with dry, filtered, compressed air (FIG 27).





Assembly of the Drum Section

1. Ensure the transfer roller contact is in place (FIG 28).



2. Replace transfer roller and transfer roller helical gear (FIG 29).

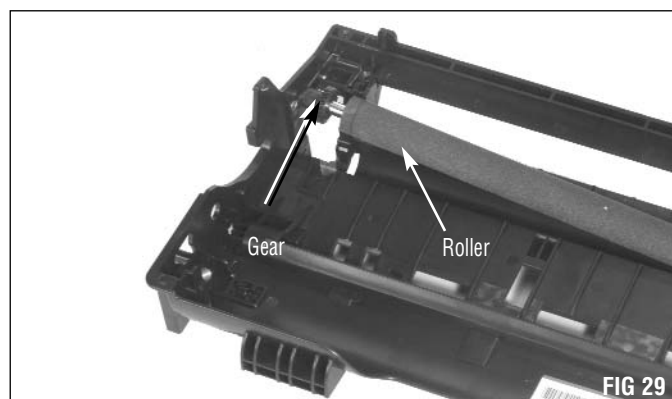

NOTE: See further instructions in System Support Series™ SSS#425 for drum and gear placement.

3. Replace the drum and gears and push the drum axle back into the cartridge (FIG 30). Replace the drum axle stabilizer bushing (FIG 31).



4. Using a Phillips screwdriver, replace the two screws securing drum cleaning assembly (FIG 32).

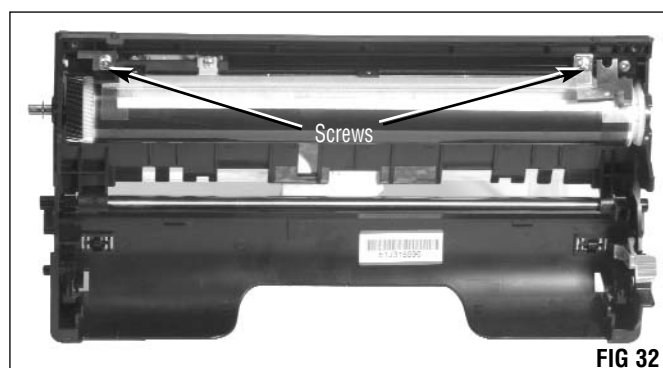

5. Reinstall the Corona Assembly and replace the e-style retaining ring on the drum axle (FIG 33).



6. Secure the corona assembly with the two screws (FIG 34).

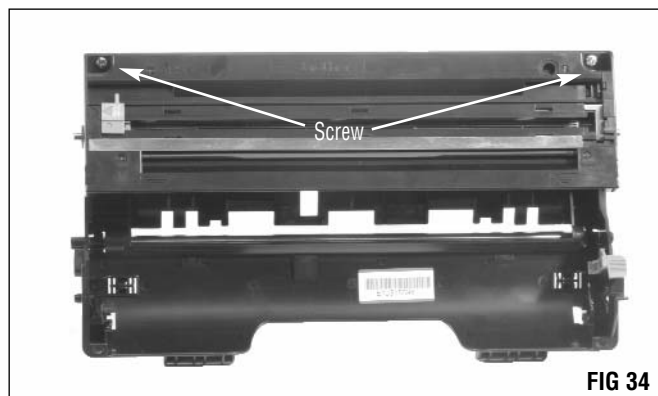



Drum Reset Information

Brother DR-510

1. With the front cover open, press and hold the GO button until all four LEDs are lit. After all LEDs are lit release the GO button and close the front cover.

Technology and Support You Can Rely On!

We realize that the success of your business directly affects the success of Static Control. It's no longer a matter of keeping up with your competition, but surpassing them. That is why we invest so much time and effort in the technology necessary for your business to address new market opportunities quickly, and with confidence.

Where monochrome once ruled the industry color is now emerging and taking a foothold. It is our pledge to you, our customer, to do all we can to help you move into this new opportunity and others, as quickly and effortlessly as possible. We will continue to support monochrome markets, while building a comprehensive color technology library for your reference, along with products to support your growing business. Together we can build a partnership for a successful future.



STATIC CONTROL

Static Control Components, Inc.
3010 Lee Avenue • PO Box 152 • Sanford, NC 27331
US/Can 800-488-2426 • US/Can Fax 800-488-2452
Int'l 919-774-3808 • Int'l Fax 919-774-1287
www.scc-inc.com

Static Control Components (Europe) Limited
Unit 30, Worton Drive
Reading • Berkshire RG2 0TG • United Kingdom
Tel +44 (0) 118 923 8800 • Fax +44 (0) 118 923 8811
www.scc-inc.com