

## **LICENSE AGREEMENT**

Static Control Components, Inc. (Static Control) grants this limited license to the person, firm or corporation (hereinafter "User") downloading electronically or by printing this file to use Static Control's copyrighted documents in accordance with the terms of this agreement. If you agree with the terms of the license then you may download this information. If you do not agree with the terms of the license, then you are not authorized to use this information, and any use of it may be in violation of Static Control's copyrights or trademarks.

## **TRADEMARKS**

The Static Control material herein may make reference to its own trademarks, or trademarks of others. Static Control grants a limited license to the User to use Static Control's trademarks in its internal documents and for its internal purposes on the following terms and conditions. Any use of Static Control's trademark must be used in a context which makes it clear that the product reference is a Static Control Components, Inc. product, and not a product from any source. The materials provided to the User may include reference to trademarks of others. Any use of the User makes of these marks should reference the owner of those marks. Nothing in this agreement constitutes any authorization by Static Control to use any of these trademarks in any context.

## **COPYRIGHTS**

Static Control grants a limited license to the User to use the attached copyrighted documents. The permitted use of these documents is limited to internal purposes and needs of the company. The company is prohibited from using these copyrighted documents, or any part of them, including graphic elements, in any materials that are used outside the physical business location of the User. The User is prohibited from using any materials in any documents whether printed or electronic, which are distributed to any third party. The use of these copyrighted documents, or parts of them, including graphic elements, from these documents in marketing material, either print, electronic or web is prohibited. The sale, transfer, copying of these documents or any parts of these documents to any other party is prohibited.

Static Control Components, Inc. retains all rights to its copyrighted documents, and any use of these documents by User should reference Static Control's copyrights, with the notice "copyright Static Control Components, Inc."

Static Control reserves the right to cancel this license on 30-days written notice. All of the User's material incorporating Static Control's copyrighted documents shall be destroyed upon receipt of its notice of termination.

The User may not distribute, share, and otherwise convey the copyrighted documents to any other persons, corporations or individuals.

The User, by use of these documents, acknowledges Static Control's copyright in these materials.

## **STATIC CONTROL DOES NOT GUARANTEE OR WARRANT DOWNLOADED INFORMATION**

The information User is downloading is published by Static Control in "as is" condition "with all faults". Static Control makes no representations or warranties of any kind concerning the quality, safety, or suitability of the downloadable materials, either express or implied, including without limitation any implied warranties of merchantability, fitness for a particular purpose, or non-infringement. Further, Static Control makes no representations or warranties as to the truth, accuracy or completeness of any statements, information or materials concerning items available for download. In no event will Static Control be liable for any indirect, punitive, special, incidental, or consequential damages however they may arise even if Static Control has been previously advised of the possibility of such damages.



The purpose of this SSS™ is to provide the information needed to properly install the drum. Before attempting to perform the following procedures, read the entire SSS™ carefully. For complete remanufacturing instructions refer to SSS™ 819.

1. Install the drum into the cartridge. Remove the e-clip, spring and washers from the drum axle as shown in Figure 1.

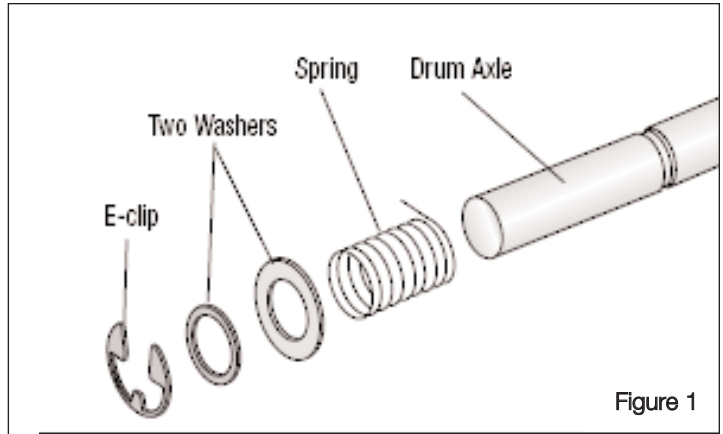

2. Gently slide the drum axle into the drum as shown in Figure 2. The drive gear contact needs to remain in contact with the drum axle as shown in Figure 3 and 4.

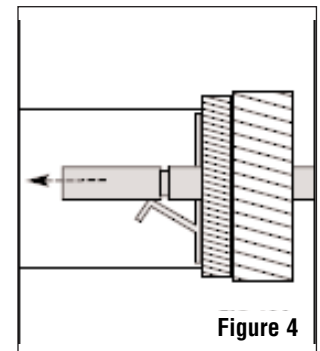
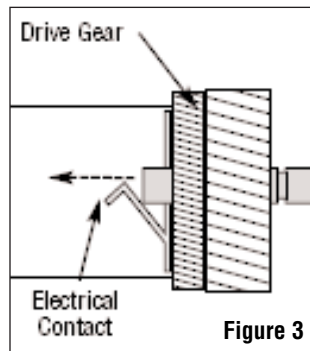
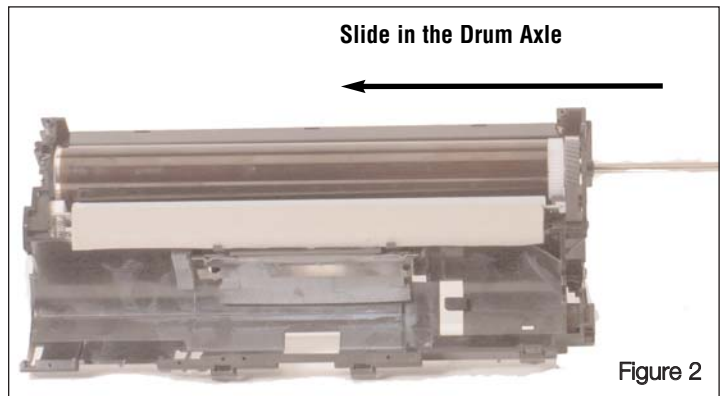

3. Attach the tension spring, washer and e-clip to the drum axle as shown in Figure 5.

