

Printer General Assy

Rev.	No.	Part No.	Description	Q'ty/ Unit	RSPL	Recommended Q'ty/Year			Remarks	RoHS -since FCS G on the way
						per 500	per 1000	per 2000		
	1	43481202	Lower_Cover Assy	1	-	-	-	-	OEL_230V CENTRO+RS+USB	-
		43481206	Lower_Cover Assy	1	-	-	-	-	OEL_230V CENTRO+RS	-
	2	43483502	Cover Upper Assy	1	-	-	-	-		-
	3	43560101	Cover access Assy	1	0	1	2	4		-
	4	43484801	Cover Rear	1	0	1	2	4		-
	5	43514501	Ribbon Protector Assy	1	0	5	10	20		-
	6	43478701	Tractor Assy	1	0	2	4	8		-
	7	43482501	Pull Up Roller Unit	1	0	2	4	8		-
	8	43471902	Printer Unit	1	-	-	-	-		-
	12	43485901	Platen knob	1	-	-	-	-		-
	13	43514801	Carriage-Stopper	1	-	-	-	-		-
	14	40485901	Label-Serial No.	1	-	-	-	-		-
	15	43560201	Sheet Guide Assy	1	0	1	2	4		-
	16	43514901	Wire guide rear	2	-	-	-	-		-
3	17	43655701	Pull up guide	1	-	-	-	-		-
2	23	43514201	Lock piece	1	-	-	-	-		-

This table lists the components and maintenance parts that are required for operating 500,1000,2000 units of this printer per year under the following conditions.

Operating condition

Mechanism ur The estimated operation time is 2hr./day and 50hr./month.

Control unit :The estimated power ON time is 8hr./day and 200hr./month.

*Parts that will affect the quantity due to maintenance conditions are not considered.

Note) For assemblies with "0" not marked in the RSPL column, the maintenance parts are not available.

Printer General Assy

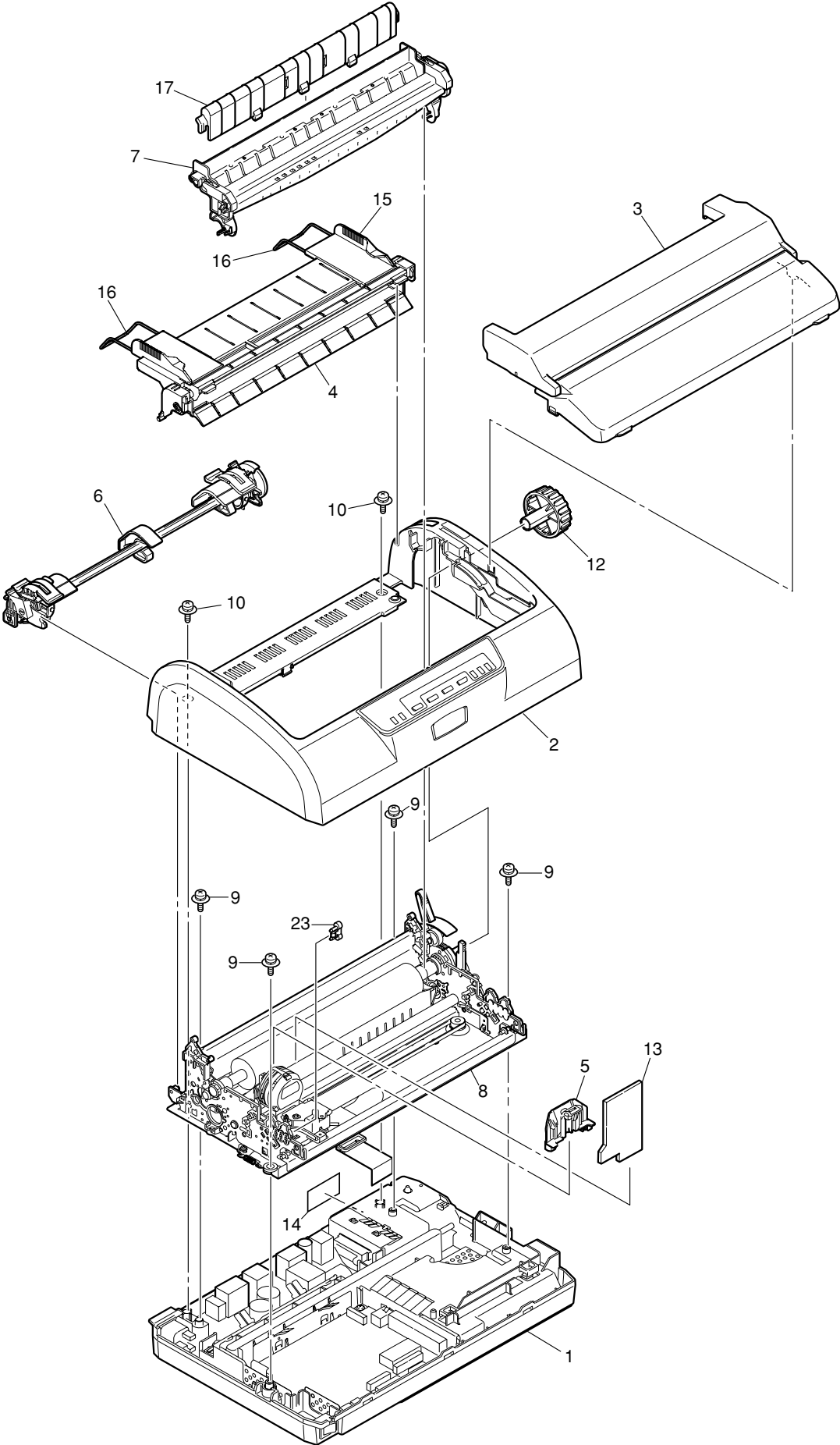

Lower Cover Assy

Rev.	No.	Part No.	Description	Q'ty/ Unit	RSPL	Recommended Q'ty/Year			Remarks	RoHS -since FCS G on the way
						per 500	per 1000	per 2000		
	1	43481301	Lower Cover	1	-	-	-	-		-
	2	43481601	Foam Sound Proof A	1	-	-	-	-		-
	3	43481901	Shield Plate F	1	-	-	-	-	CENTRO+RS+USB	-
		43481902	Shield Plate F	1	-	-	-	-	CENTRO+RS	-
	4	43482001	Plate shield Rear Lower	1	-	-	-	-		-
	5	43482101	Plate FG	4	-	-	-	-		-
3	7	43440902	Board-L24	1	0	3	6	12	OEL CENTRO+RS+USB	-
		43440904	Board-L24	1	0	3	6	12	OEL CENTRO+RS	-
3	8	43703901	PWR unit-ACDC Switch	1	0	3	6	12	100VAC127VAC	-
		43703902	PWR unit-ACDC Switch	1	0	3	6	12	220VAC240VAC	-
	9	43560001	POW Cord Bending Figure	1	0	3	6	12		-
	10	43390801	Conn-Cord-RS232C	1	0	3	6	12	Only RS	-
	11	43560501	sheet insulation	1	-	-	-	-		-
2	14	43607001	FG PLATE A	1	-	-	-	-		-
2	15	43607201	FG PLATE E	1	-	-	-	-		-
2	16	43623801	FG PLATE C	1	-	-	-	-		-
2	17	42972401	Washer	1	-	-	-	-		-

Note) For assemblies with "0" not marked in the RSPL column, the maintenance parts are not available.

Lower Cover Assy

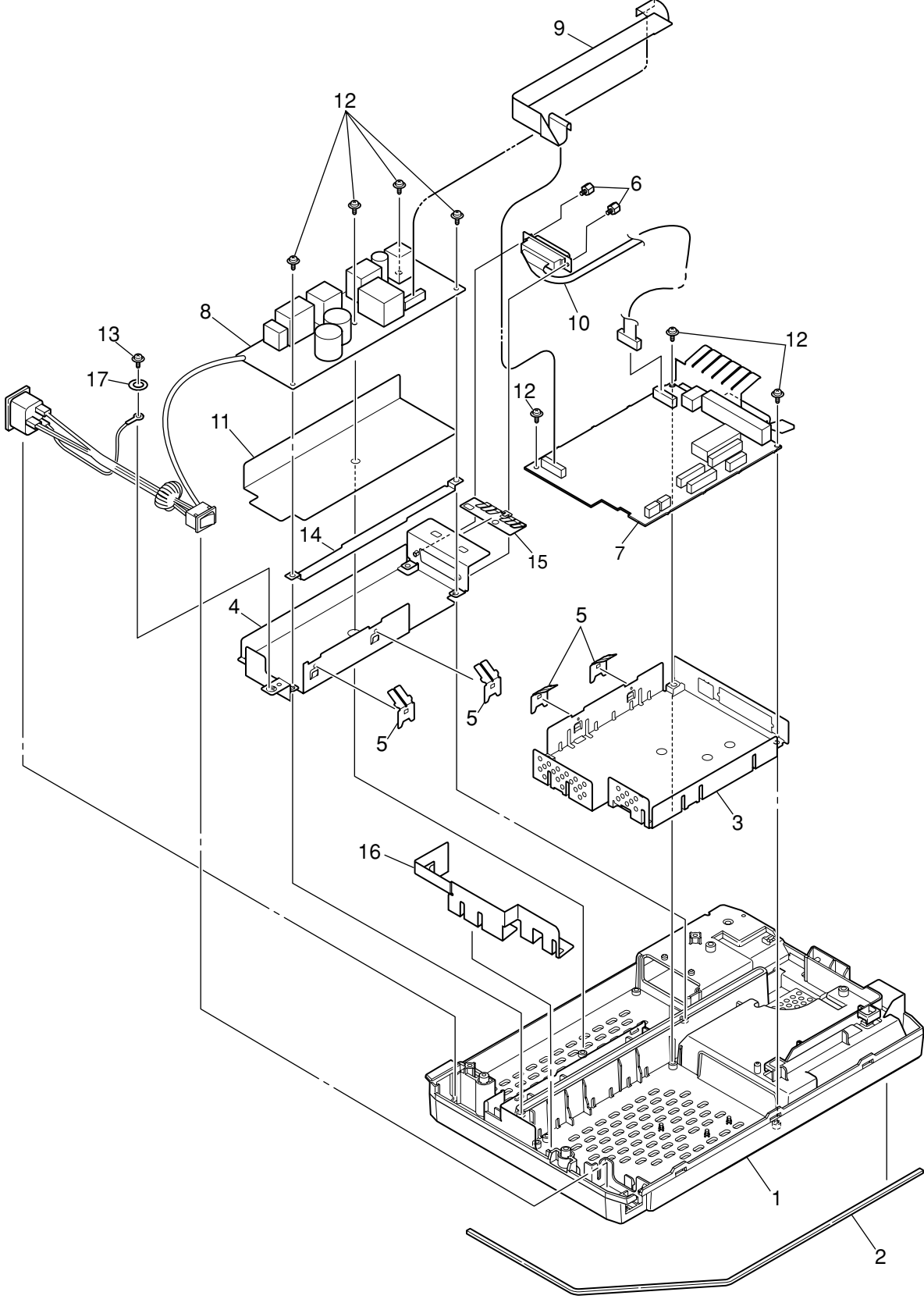

Cover Upper Assy

Rev.	No.	Part No.	Description	Q'ty/ Unit	RSPL	Recommended Q'ty/Year			Remarks	RoHS -since FCS G on the way
						per 500	per 1000	per 2000		
	1	43483701	Cover Upper	1	0	1	2	4		-
	3	43483802	Sheet Operation Panel	1	0	1	2	4		-
	4	43483901	OP panel frame	1	-	-	-	-		-
	5	43516304	Board-LSO	1	0	3	6	12		-
	6	43559701	OP Cord Bending Figure	1	0	3	6	12		-
3	7	1051011C0001	Core	1	-	-	-	-		-

Note) For assemblies with "0" not marked in the RSPL column, the maintenance parts are not available.

Cover Upper Assy

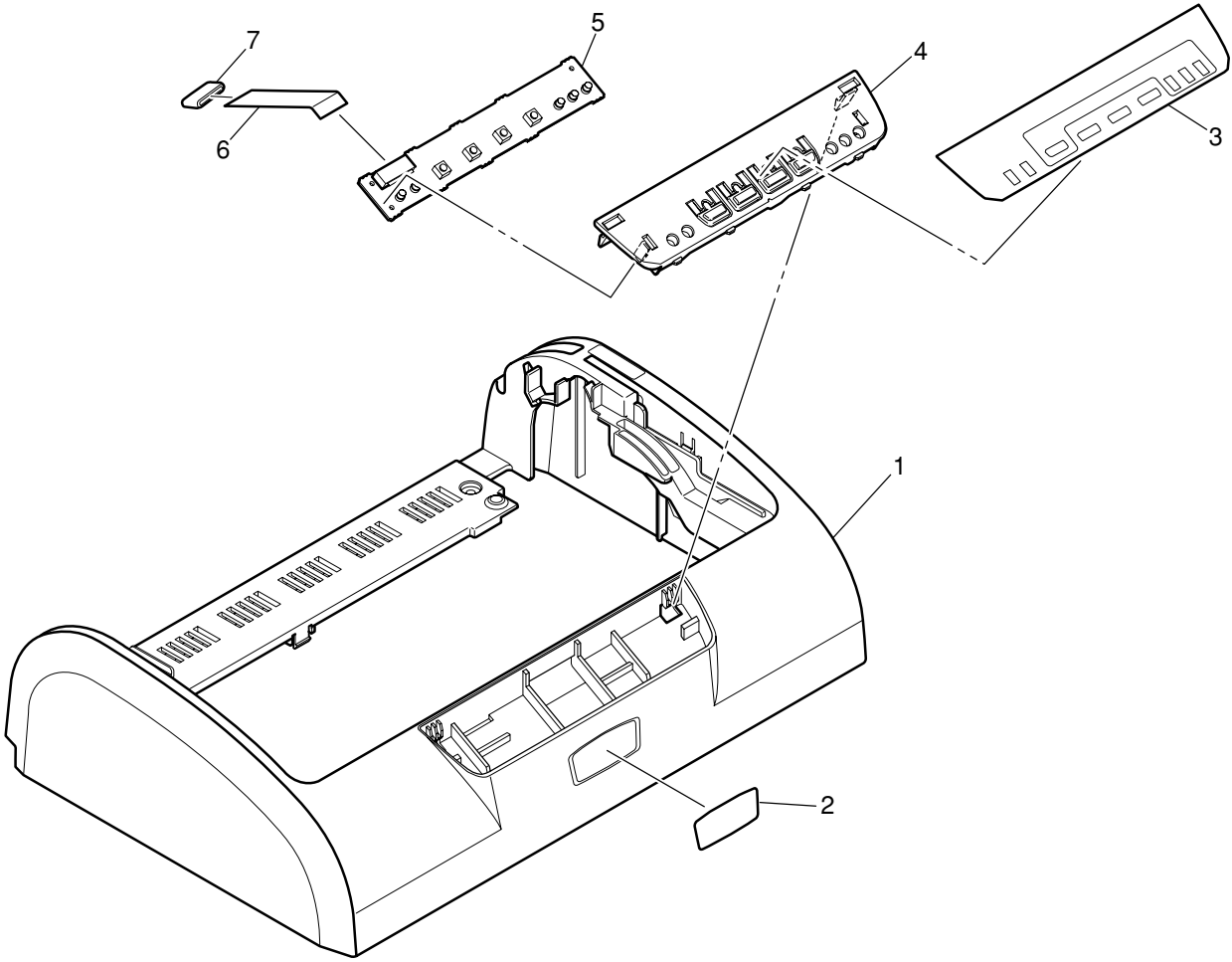

Ribbon Protecto Assy

Rev.	No.	Part No.	Description	Q'ty/ Unit	RSPL	Recommended Q'ty/Year			Remarks	RoHS -since FCS G on the way
						per 500	per 1000	per 2000		
	1	43476201	Ribbon Protector Bracket	1	0	5	10	20		-
	2	43498001	Ribbon Protector	1	0	5	10	20		-

Note) For assemblies with "0" not marked in the RSPL column, the maintenance parts are not available.

Ribbon Protecto Assy

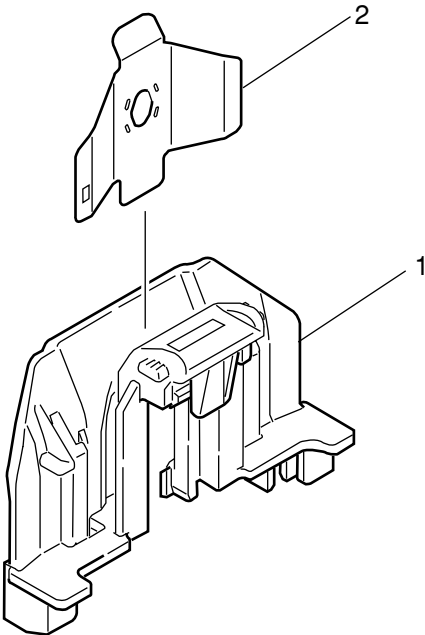

Printer Unit

Rev.	No.	Part No.	Description	Q'ty/ Unit	RSPL	Recommended Q'ty/Year			Remarks	RoHS -since FCS G on the way
						per 500	per 1000	per 2000		
	1	43472101	Lower-Base	1	-	-	-	-		-
	2	43473301	Guide-Beam	1	-	-	-	-		-
	3	43473401	Front-Beam	1	-	-	-	-		-
	4	SPP3-10SUS	PIN(φ3-10)	4	-	-	-	-		-
	6	43534801	Side Frame L Outsert	1	-	-	-	-		-
	7	43534901	Side Frame R Outsert	1	-	-	-	-		-
	8	43473501	Rear beam	1	-	-	-	-		-
	9	43475301	Carriage Shaft	1	-	-	-	-		-
	10	43441601	head (24Pin)	1	0	20	40	80		-
	11	43517602	Carriage Assy	1	-	-	-	-		-
	12	43473701	Stepping Motor	1	0	5	10	20		-
	14	43509702	Stepping Motor	1	0	5	10	20		-
	15	43473901	Ribbon Feed Assy	1	0	2	4	8		-
3	16	43640701	Idle pulley bracket	1	0	2	4	8		-
3	17	43640801	Washer Idle Pulley	1	0	2	4	8		-
	18	43473801	Idle pulley	1	0	2	4	8		-
	20	43473201	Paper pan	1	-	-	-	-		-
	21	43478201	Roller F(Rubber)	2	-	-	-	-		-
	22	43478301	Roller R(Rubber)	2	-	-	-	-		-
	23	43478401	Roller Frame	2	-	-	-	-		-
	25	43478601	Shaft Release	1	-	-	-	-		-
	26	43532901	Bottom-Paper End	1	0	3	6	12		-
	27	40135301	Photo-Interrupter	1	0	3	6	12		-
	28	43519401	Conn Cord Sensor(6P)	1	0	5	10	20		-
	29	43536701	Sensor arm	1	-	-	-	-		-
	30	43536801	Sensor arm Holder	1	-	-	-	-		-
	32	43480401	Platen Coller L	1	-	-	-	-		-
	33	43480201	Platen Assy	1	0	10	20	40		-
	35	43476801	Adjust lever(HG)	1	-	-	-	-		-
	36	43476901	Adjust Knob	1	-	-	-	-		-
	37	43477101	LF motor plate	1	-	-	-	-		-
	39	43477301	Pull up gear	1	-	-	-	-		-
	42	43477601	Change washer	1	-	-	-	-		-
	43	43477701	Release lever	1	-	-	-	-		-
	44	43475401	Rubber foot	4	-	-	-	-		-
	45	43532801	Gap SW	1	0	3	6	12		-
	46	43519501	Conn Cord Sensor(7P)	1	0	5	10	20		-

Note) For assemblies with "0" not marked in the RSPL column, the maintenance parts are not available.

Printer Unit

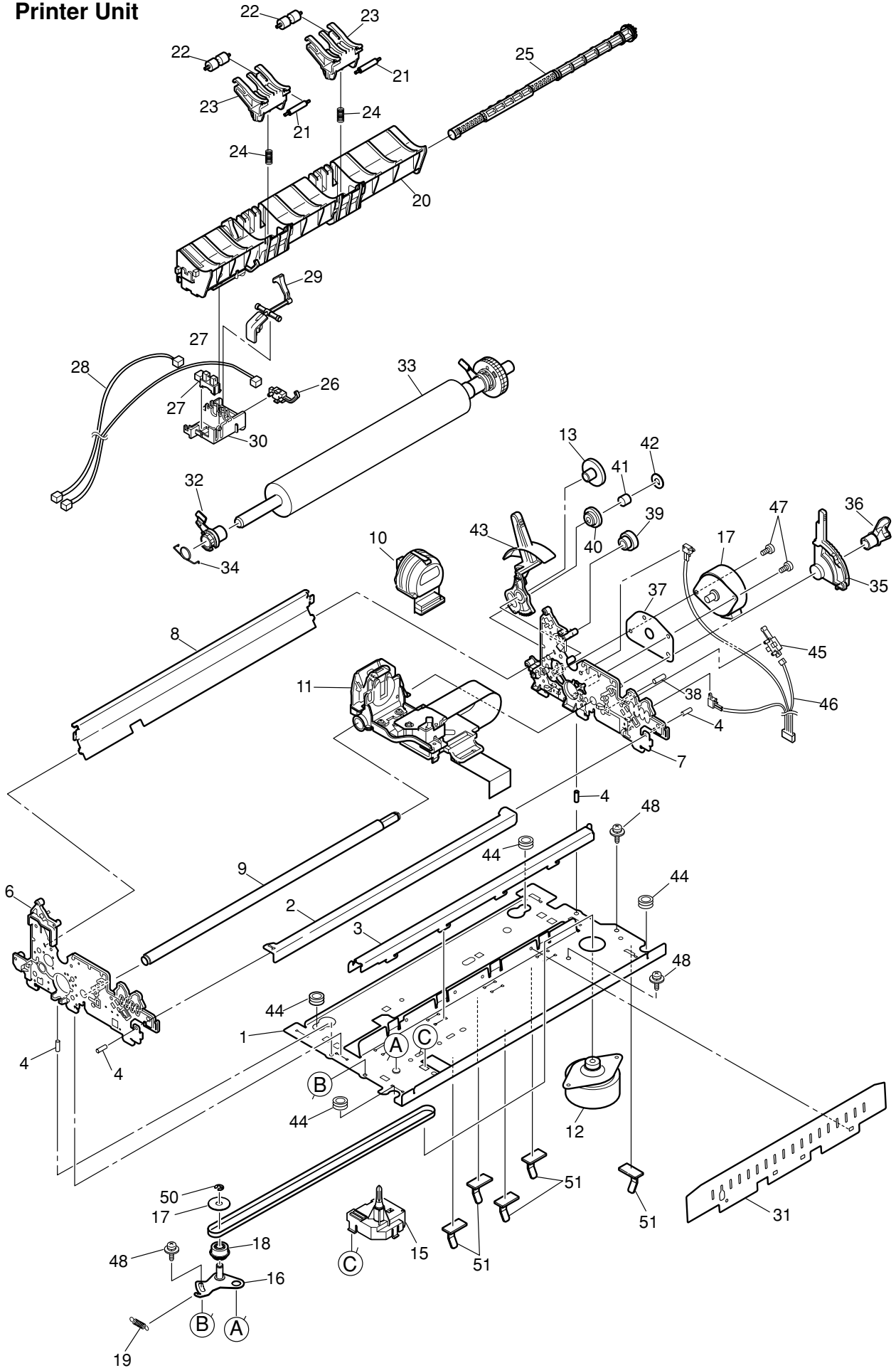

Carriage Assy

Rev.	No.	Part No.	Description	Q'ty/ Unit	RSPL	Recommended Q'ty/Year			Remarks	RoHS -since FCS G on the way
						per 500	per 1000	per 2000		
	1	43475701	Carriage Frame	1	-	-	-	-		-
	2	43476001	Carriage Plate	1	-	-	-	-		-
	3	43476301	SP Belt	1	0	3	6	12		-
	4	43476401	Guide Cable	1	-	-	-	-		-
	5	43476501	Slider	1	-	-	-	-		-
	6	43476601	Clamp Head	1	-	-	-	-		-
	7	43510201	Piece Slider	1	-	-	-	-		-
	8	43510101	Film Guide	1	-	-	-	-		-
	9	43559801	Head Cord(16) Bending Figure	1	0	3	6	13		-
	10	43559901	Head Cord(20) Bending Figure	1	0	3	6	13		-
	11	43514301	Clamp Head Cable	1	-	-	-	-		-
	12	40135301	Photo-Interrupter	1	0	3	6	13		-
	13	43519301	Conn Cord Sensor(3P)	1	0	5	10	20		-

Note) For assemblies with "0" not marked in the RSPL column, the maintenance parts are not available.

Carriage Assy

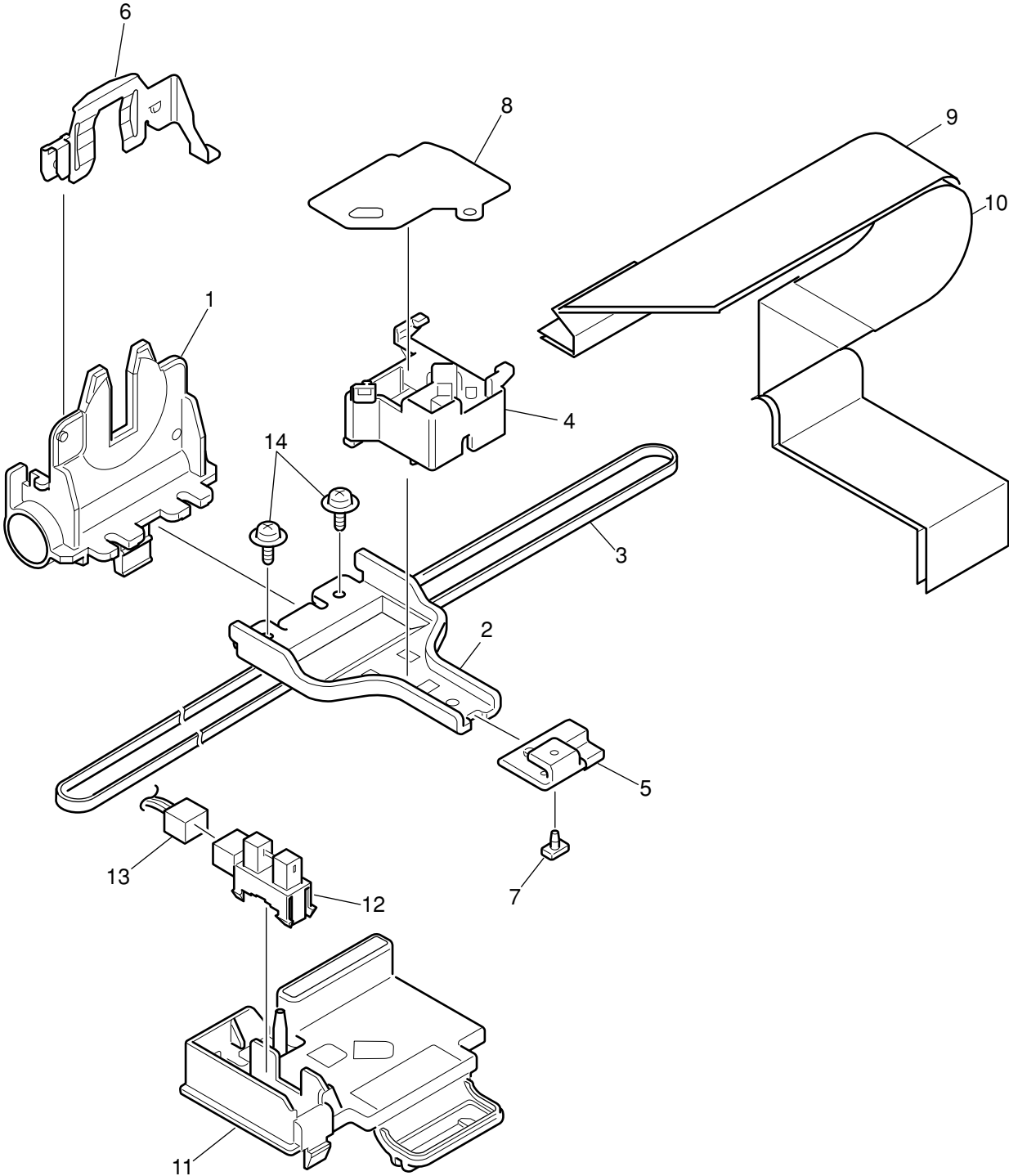

L24 Printed Corcuit Board

Rev.	No.	Part No.	Description	Q'ty/ Unit	RSPL	Recommended Q'ty/Year			Remarks	RoHS -since FCS G on the way
						per 500	per 1000	per 2000		
	1	5402202S210	217001.MXP Fuse	2	0	10	20	40		-
	2	8155632M000	M27C322-80S1(32M OTPROM 80	1	0	5	10	20	Before the programming	-

Note) For assemblies with "0" not marked in the RSPL column, the maintenance parts are not available.

L24-Printed Circuit Board

