

PARTS CATALOG

imageRUNNER 2030i/2025i/2022i/ 2022/2018i/2018 DADF-P2 Duplex Unit-B1 Super G3 Fax Board-AA1



Canon

DU7-3200-000

SEPTEMBER 2007
REV. 0

PREFACE

This Parts Catalog contains listings of parts used

Diagrams are provided with the listings to aid the service technician in identifying clearly, the item to be ordered.

Whenever ordering parts, consult this Parts Catalog for all of the information pertaining to each item. Be sure to include, in the Parts Request, the full item description, the item part number, and the quantity.

COPYRIGHT (C) 1999 CANON INC.

Use of this manual should be strictly supervised to avoid disclosure of confidential information.

Contents

NUMERICAL INDEX

iR2030/2025/2022/2018 Series(Numerical Index)..... 1-1

iR2030/2025/2022/2018 Series(Parts Catalog)

A	ASSEMBLY LOCATION DIAGRAM	2-1
001	ACCESSORIES	2-6
100	EXTERNAL COVERS, PANELS, ETC.	2-8
101	MACHINE FRONT PLATE	2-12
102	INTERNAL COMPONENTS	2-14
103	INTERNAL COMPONENTS	2-16
104	MACHINE REAR PLATE	2-20
130	CONTROL PANEL ASSEMBLY	2-22
140	LEFT DOOR ASSEMBLY	2-24
141	TRANSFER MOUNT ASSEMBLY	2-28
210	READER ASSEMBLY	2-30
250	MAIN DRIVE ASSEMBLY	2-36
280	FIXING DRIVE ASSEMBLY	2-37
300	CASSETTE	2-38
310	CASSETTE FEEDER ASSEMBLY	2-40
311	PAPER PICK-UP ASSEMBLY	2-42
312	CASSETTE FEEDER ASSEMBLY(iR2030/2025/2022 Series)	2-46
313	PAPER PICK-UP ASSEMBLY(iR2030/2025/2022 Series)	2-48
315	MULTI FEED TRAY ASS'Y	2-52
350	PAPER DELIVERY ASSEMBLY	2-54
640	DEVELOPING ASSEMBLY	2-56
810	FIXING ASSEMBLY	2-58
900	IMAGE PROCESSOR PCB ASS'Y	2-61
C10	COPYBOARD COVER ASSEMBLY	2-62
P01	PACKING KIT	2-64
P11	ADF ASSEMBLY	2-66
P12	DOCUMENT TRAY ASSEMBLY	2-70
P31	OPEN/CLOSE PANEL ASSEMBLY	2-72
P33	PAPER FEEDER ASSEMBLY	2-74
S01	PACKING KIT	2-78
S20	DUPLEX FEEDER ASSEMBLY	2-80
S50	DUPLEX REVERSE UNIT	2-83
X10	FAX ASSEMBLY	2-84
ZZA	MECHANICAL STANDARD PARTS (HOW TO USE)	2-86
ZZB	MECHANICAL STANDARD PARTS (SCREWS)	2-87

Contents

ZZC	MECHANICAL STANDARD PARTS (BOLTS)	2-94
ZZD	MECHANICAL STANDARD PARTS (NUTS)	2-95
ZZE	MECHANICAL STANDARD PARTS (WASHERS)	2-96
ZZF	MECHANICAL STANDARD PARTS (RETAINING RINGS)	2-99
ZZG	MECHANICAL STANDARD PARTS (PINS)	2-102
ZZH	MECHANICAL STANDARD PARTS (SPACERS)	2-103

NUMERICAL INDEX

IR2030/2025/2022/2018 Series(Numerical Index)

PARTS NUMBER	FIGURE & KEY NO.	PARTS NUMBER	FIGURE & KEY NO.	PARTS NUMBER	FIGURE & KEY NO
FA3-8727-000	103 - 19	FB6-1908-000	313 - 31	FC3-1549-000	P33 - 15
FA8-2447-000	312 - 12	FB6-1909-000	311 - 5	FC3-1568-000	P33 - 53
FA8-2448-000	313 - 1	FB6-1909-000	313 - 23	FC3-1569-000	P11 - 39
FA8-2449-000	313 - 2	FB6-1910-000	310 - 5	FC3-1571-000	P01 - 1
FA9-2112-000	103 - 11	FB6-1910-000	312 - 7	FC3-1572-000	P01 - 2
FA9-3870-000	100 - 22	FB6-1920-000	312 - 14	FC5-0543-000	140 - 24
FB4-5532-000	310 - 1	FB6-1996-000	312 - 15	FC5-0792-000	210 - 12
FB4-5532-000	312 - 2	FB6-1997-000	312 - 16	FC5-1427-000	210 - 50
FB4-5808-020	300 - 18	FB6-2000-000	300 - 4	FC5-1444-000	210 - 13
FB4-5809-020	300 - 9	FB6-6896-000	640 - 24	FC5-1452-000	210 - 55
FB4-5810-000	300 - 11	FC3-1449-000	P11 - 10	FC5-5264-000	810 - 4
FB4-5813-020	300 - 10	FC3-1450-000	P11 - 11	FC5-5265-000	810 - 26
FB4-5814-000	300 - 1	FC3-1451-000	P11 - 23	FC5-6805-000	810 - 22
FB4-5824-000	300 - 19	FC3-1452-000	P11 - 12	FC5-6806-000	810 - 1
FB4-6032-000	313 - 3	FC3-1454-000	P11 - 13	FC6-4113-000	101 - 1
FB4-6033-000	313 - 4	FC3-1455-000	P11 - 14	FC6-4114-000	101 - 14
FB4-6034-000	313 - 5	FC3-1460-000	P33 - 1	FC6-4115-000	101 - 15
FB4-9817-030	311 - 25	FC3-1462-000	P33 - 2	FC6-4116-000	101 - 21
FB4-9817-030	313 - 39	FC3-1465-000	P33 - 4	FC6-4118-000	102 - 11
FB5-9410-000	001 - 5	FC3-1466-000	P33 - 5	FC6-4120-000	101 - 16
FB6-1336-000	210 - 48	FC3-1468-000	P11 - 1	FC6-4135-000	102 - 19
FB6-1337-000	210 - 49	FC3-1469-000	P33 - 6	FC6-4138-000	103 - 27
FB6-1536-000	312 - 13	FC3-1470-000	P33 - 7	FC6-4143-020	101 - 3
FB6-1541-000	313 - 33	FC3-1471-000	P33 - 8	FC6-4146-020	101 - 4
FB6-1550-000	311 - 1	FC3-1477-000	P31 - 2	FC6-4147-000	101 - 19
FB6-1550-000	313 - 6	FC3-1478-000	P31 - 3	FC6-4148-000	103 - 20
FB6-1551-000	313 - 7	FC3-1479-000	P31 - 4	FC6-4149-000	101 - 5
FB6-1608-000	310 - 2	FC3-1480-000	P31 - 5	FC6-4163-000	640 - 16
FB6-1608-000	312 - 3	FC3-1486-000	P12 - 2	FC6-4164-000	640 - 2
FB6-1613-000	313 - 8	FC3-1488-000	P12 - 3	FC6-4165-000	640 - 3
FB6-1614-000	313 - 9	FC3-1491-000	P11 - 15	FC6-4166-000	640 - 4
FB6-1615-000	313 - 10	FC3-1492-000	P11 - 2	FC6-4167-000	640 - 5
FB6-1616-000	313 - 11	FC3-1493-000	P33 - 9	FC6-4168-000	640 - 6
FB6-1623-000	313 - 12	FC3-1494-000	P33 - 10	FC6-4169-000	640 - 7
FB6-1624-000	313 - 13	FC3-1495-000	P11 - 16	FC6-4170-000	640 - 8
FB6-1626-000	311 - 2	FC3-1496-000	P11 - 3	FC6-4176-000	640 - 11
FB6-1626-000	313 - 14	FC3-1497-000	P11 - 17	FC6-4177-000	640 - 12
FB6-1628-000	313 - 15	FC3-1498-000	P11 - 18	FC6-4191-000	103 - 40
FB6-1631-030	313 - 40	FC3-1509-000	P33 - 11	FC6-4202-000	640 - 17
FB6-1634-000	313 - 18	FC3-1510-000	P33 - 12	FC6-4205-000	103 - 43
FB6-1635-000	313 - 19	FC3-1511-000	P33 - 13	FC6-4209-020	140 - 9
FB6-1636-000	313 - 20	FC3-1512-000	P33 - 14	FC6-4210-000	140 - 10
FB6-1640-000	300 - 2	FC3-1513-000	P11 - 24	FC6-4211-000	140 - 11
FB6-1644-000	300 - 3	FC3-1525-000	P31 - 11	FC6-4215-000	315 - 1
FB6-1646-000	300 - 12	FC3-1529-000	P12 - 5	FC6-4218-000	315 - 2
FB6-1649-000	300 - 13	FC3-1539-000	P11 - 4	FC6-4219-000	315 - 3
FB6-1650-000	300 - 7	FC3-1540-000	P31 - 6	FC6-4220-000	315 - 4
FB6-1660-000	311 - 4	FC3-1541-000	P31 - 7	FC6-4221-000	315 - 5
FB6-1660-000	313 - 21	FC3-1542-000	P31 - 12	FC6-4222-000	315 - 6
FB6-1722-000	104 - 1	FC3-1547-000	P01 - 3	FC6-4223-000	315 - 7
FB6-1905-000	313 - 22	FC3-1549-000	P11 - 19	FC6-4224-000	140 - 12
FB6-1908-000	311 - 20	FC3-1549-000	P31 - 13	FC6-4227-020	140 - 14

NUMERICAL INDEX

iR2030/2025/2022/2018 Series(Numerical Index)

PARTS NUMBER	FIGURE & KEY NO.	PARTS NUMBER	FIGURE & KEY NO.	PARTS NUMBER	FIGURE & KEY NO
FC6-4232-000	140 - 15	FC6-4356-000	311 - 28	FC6-4559-000	210 - 39
FC6-4234-000	140 - 17	FC6-4356-000	313 - 41	FC6-4560-000	210 - 56
FC6-4235-000	102 - 1	FC6-4357-000	310 - 3	FC6-4561-000	210 - 40
FC6-4238-000	140 - 18	FC6-4357-000	312 - 4	FC6-4562-000	210 - 19
FC6-4239-000	140 - 19	FC6-4358-000	311 - 15	FC6-4573-000	210 - 16
FC6-4244-000	102 - 25	FC6-4358-000	313 - 27	FC6-4576-000	C10 - 3
FC6-4245-000	103 - 44	FC6-4360-000	103 - 18	FC6-4580-000	100 - 21
FC6-4259-000	100 - 3	FC6-4361-000	300 - 6	FC6-4582-000	210 - 5
FC6-4262-000	100 - 6	FC6-4375-000	810 - 39	FC6-4689-000	103 - 47
FC6-4264-000	100 - 8	FC6-4377-000	140 - 20	FC6-4690-000	101 - 6
FC6-4265-000	100 - 9	FC6-4386-000	140 - 3	FC6-4691-000	104 - 7
FC6-4266-000	100 - 10	FC6-4388-000	140 - 4	FC6-4693-000	102 - 24
FC6-4267-000	100 - 11	FC6-4391-000	100 - 2	FC6-4710-000	102 - 5
FC6-4268-000	100 - 12	FC6-4399-000	103 - 6	FC6-4720-000	102 - 6
FC6-4269-000	100 - 13	FC6-4413-000	140 - 5	FC6-4727-000	210 - 17
FC6-4271-000	100 - 15	FC6-4414-000	140 - 6	FC6-4734-000	102 - 7
FC6-4272-000	100 - 14	FC6-4435-000	103 - 7	FC6-4738-000	C10 - 4
FC6-4273-000	100 - 16	FC6-4436-000	250 - 1	FC6-5425-000	130 - 1
FC6-4284-000	311 - 26	FC6-4437-000	250 - 2	FC6-5426-000	130 - 2
FC6-4288-000	313 - 51	FC6-4438-020	350 - 2	FC6-5427-000	130 - 3
FC6-4288-020	311 - 47	FC6-4446-000	103 - 8	FC6-5428-000	130 - 4
FC6-4290-000	311 - 21	FC6-4447-000	103 - 9	FC6-5429-000	130 - 5
FC6-4290-000	313 - 32	FC6-4454-000	810 - 41	FC6-5430-000	130 - 6
FC6-4291-000	311 - 8	FC6-4458-020	810 - 38	FC6-5431-000	130 - 7
FC6-4297-000	310 - 9	FC6-4465-000	350 - 13	FC6-6706-000	312 - 5
FC6-4298-000	310 - 10	FC6-4467-000	810 - 43	FC6-6707-000	312 - 24
FC6-4300-000	310 - 11	FC6-4470-000	350 - 4	FC6-6710-000	312 - 22
FC6-4304-000	311 - 9	FC6-4473-000	350 - 14	FC6-6712-000	312 - 26
FC6-4304-000	313 - 24	FC6-4474-000	350 - 5	FC6-6714-000	312 - 17
FC6-4306-000	103 - 3	FC6-4476-000	100 - 1	FC6-6720-000	312 - 1
FC6-4307-000	103 - 52	FC6-4477-000	350 - 3	FC6-6740-000	S20 - 23
FC6-4308-000	103 - 34	FC6-4481-000	810 - 9	FC6-6752-000	S20 - 1
FC6-4309-000	103 - 35	FC6-4484-000	350 - 15	FC6-6753-000	S20 - 2
FC6-4310-000	103 - 36	FC6-4495-000	103 - 10	FC6-6754-000	S20 - 15
FC6-4311-000	103 - 4	FC6-4497-000	250 - 3	FC6-6755-000	S20 - 3
FC6-4312-000	103 - 5	FC6-4499-000	X10 - 3	FC6-6756-000	S20 - 4
FC6-4313-000	141 - 7	FC6-4500-000	X10 - 4	FC6-6757-000	S20 - 5
FC6-4314-000	141 - 1	FC6-4502-000	350 - 7	FC6-6758-000	S20 - 6
FC6-4315-000	141 - 2	FC6-4504-000	350 - 19	FC6-6759-000	S20 - 7
FC6-4316-000	141 - 11	FC6-4506-000	210 - 30	FC6-6759-000	S50 - 2
FC6-4317-000	141 - 3	FC6-4508-000	C10 - 1	FC6-6760-000	S20 - 8
FC6-4324-000	141 - 4	FC6-4509-000	C10 - 2	FC6-6765-000	S20 - 9
FC6-4326-000	311 - 10	FC6-4511-000	210 - 37	FC6-6768-000	S20 - 11
FC6-4337-000	300 - 5	FC6-4513-000	100 - 26	FC6-6769-000	S20 - 25
FC6-4350-000	311 - 12	FC6-4514-000	210 - 31	FC6-6778-000	S01 - 5
FC6-4350-000	313 - 36	FC6-4519-000	100 - 19	FC6-6779-000	S50 - 3
FC6-4351-000	311 - 27	FC6-4522-000	210 - 2	FC6-6780-000	S50 - 4
FC6-4351-000	313 - 35	FC6-4525-000	210 - 51	FC6-6781-000	S50 - 1
FC6-4352-000	311 - 13	FC6-4528-000	210 - 14	FC6-6782-000	S01 - 1
FC6-4352-000	313 - 25	FC6-4529-000	100 - 20	FC6-6783-000	S01 - 2
FC6-4355-000	311 - 14	FC6-4541-000	210 - 15	FC6-7092-000	101 - 8
FC6-4355-000	313 - 26	FC6-4558-000	210 - 20	FC6-7103-000	140 - 7

NUMERICAL INDEX

iR2030/2025/2022/2018 Series(Numerical Index)

PARTS NUMBER	FIGURE & KEY NO.	PARTS NUMBER	FIGURE & KEY NO.	PARTS NUMBER	FIGURE & KEY NO
FC7-1020-000	130 - 9	FF3-4621-000	P11 - 5	FK2-1064-000	210 - 8
FC7-1749-000	104 - 17	FF3-4624-000	P11 - 7	FK2-1066-020	210 - 28
FC7-1757-020	101 - 3	FF3-4625-000	P12 - 4	FK2-1070-000	140 - 21
FC7-1770-000	311 - 44	FF3-4626-000	P12 - 6	FK2-1072-000	140 - 22
FC8-0134-000	130 - 8	FF3-4627-000	P12 - 8	FK2-1082-000	311 - 18
FC8-0139-000	100 - 4	FF3-4628-000	P12 - 9	FK2-1104-000	313 - 29
FC8-0140-000	100 - 5	FF3-4629-000	P31 - 8	FK2-1265-000	X10 - 11
FC8-0142-000	102 - 3	FF3-4630-000	P31 - 9	FK2-5122-000	104 - 21
FC8-0158-000	311 - 11	FF3-4631-000	P33 - 19	FK2-5347-000	103 - 48
FC8-0164-000	311 - 7	FF3-4632-000	P33 - 20	FK2-5348-000	102 - 10
FC8-0165-000	140 - 32	FF3-4633-000	P33 - 16	FK2-5350-000	103 - 12
FC8-0166-000	140 - 50	FF3-4634-000	P11 - 8	FK2-5355-000	103 - 13
FC8-0167-000	140 - 16	FF3-4636-000	P33 - 17	FK2-5356-000	103 - 13
FC8-0168-000	140 - 13	FF3-4637-000	P31 - 8	FK2-5359-000	S20 - 17
FC8-0183-000	810 - 42	FF3-4638-000	P33 - 3	FK2-5367-000	311 - 17
FC8-0184-000	810 - 5	FF6-1610-000	313 - 34	FK2-5368-000	140 - 8
FC8-0185-000	810 - 6	FF6-1621-000	311 - 16	FK2-5376-000	104 - 2
FC8-0189-000	810 - 16	FF6-1621-000	313 - 28	FK2-5714-000	001 - 1
FC8-0190-000	810 - 19	FG3-4036-000	P12 -	FK2-5715-000	001 - 2
FC8-0191-000	810 - 21	FG3-4037-000	P31 -	FK2-5716-000	001 - 3
FC8-0192-000	810 - 45	FG3-4038-020	P33 -	FK2-5718-000	001 - 4
FC8-0193-000	810 - 46	FG3-4039-000	P11 - 22	FK2-5787-000	P11 - 34
FC8-0194-000	810 - 47	FG3-4040-000	P33 - 18	FL2-3180-000	102 - 12
FC8-0195-000	810 - 48	FG3-4041-000	P31 - 14	FL2-3181-000	102 - 13
FC8-0196-000	810 - 17	FG3-4043-000	P31 - 10	FL2-3186-000	C10 - 5
FC8-0197-000	810 - 3	FG3-4044-000	P31 - 15	FL2-3188-000	210 - 52
FC8-0198-000	810 - 7	FG3-4045-000	P31 - 16	FL2-3193-000	640 - 13
FC8-0199-000	810 - 8	FG3-4052-000	P31 -	FL2-3194-000	640 - 14
FC8-0200-000	810 - 10	FG6-8440-000	312 - 6	FL2-3197-000	640 - 15
FC8-0203-000	810 - 44	FH2-7206-000	P11 - 32	FL2-3200-000	140 - 23
FC8-0204-000	810 - 11	FH2-7207-000	P12 - 10	FL2-3201-000	140 - 25
FC8-0207-000	810 - 49	FH2-7208-000	P12 - 11	FL2-3202-000	140 - 26
FC8-0208-000	810 - 34	FH2-7209-000	P33 - 25	FL2-3206-000	210 - 24
FC8-0209-000	350 - 1	FH2-7210-000	P11 - 33	FL2-3207-000	210 - 24
FC8-0214-000	102 - 4	FH2-7211-000	P11 - 25	FL2-3208-000	210 - 24
FC8-0215-000	350 - 6	FH2-7212-000	P12 - 12	FL2-3212-000	311 - 22
FC8-0232-000	140 - 2	FH5-1142-000	P33 - 49	FL2-3220-000	350 - 8
FC8-0248-000	101 - 2	FH5-3543-000	141 - 5	FL2-3229-000	104 - 15
FC8-0249-000	101 - 13	FH5-3731-000	P12 - 13	FL2-3230-000	210 - 21
FC8-0256-000	311 - 6	FH6-0772-000	130 - 10	FL2-3231-000	210 - 53
FC8-0257-000	311 - 46	FH6-5136-000	P11 - 26	FL2-3233-000	210 - 54
FC8-0312-000	S20 - 10	FH7-7569-000	210 - 26	FL2-3268-000	100 - 23
FC8-0313-000	S20 - 28	FH7-7569-000	210 - 26	FL2-3269-000	100 - 24
FC8-0317-000	S20 - 13	FH7-7569-000	210 - 26	FL2-3286-000	210 - 38
FC8-0318-000	S20 - 12	FK2-0216-000	P11 - 20	FL2-3304-000	640 - 10
FC8-0320-000	140 - 48	FK2-0949-000	900 - IC	FL2-3463-000	130 - 11
FC8-0321-000	140 - 49	FK2-0949-000	X10 - IC	FL2-3736-000	312 - 20
FC8-0336-000	103 - 51	FK2-1059-000	104 - 3	FL2-3744-000	S20 - 26
FC8-0340-000	141 - 14	FK2-1060-000	210 - 7	FL2-3856-000	S20 - 14
FC8-0634-000	P01 - 11	FK2-1061-000	210 - 18	FL2-8054-000	130 - 12
FE5-4048-000	311 - 29	FK2-1062-000	102 - 9	FL2-8055-000	130 - 12
FE5-4048-000	313 - 42	FK2-1063-000	X10 - 2	FL2-8061-000	103 - 2

NUMERICAL INDEX

iR2030/2025/2022/2018 Series(Numerical Index)

PARTS NUMBER	FIGURE & KEY NO.	PARTS NUMBER	FIGURE & KEY NO.	PARTS NUMBER	FIGURE & KEY NO
FL2-8063-000	141 - 6	FM2-4520-000	S20 - 33	FM3-3640-000	141 -
FL2-8066-000	103 - 15	FM2-4535-000	210 - 34	FM3-3643-000	310 - 15
FL2-8083-000	104 - 5	FM2-4536-000	210 - 47	FM3-3650-000	810 -
FL2-8094-000	S01 - 4	FM2-4537-000	210 - 47	FM3-3651-000	810 -
FL2-9379-000	100 - 7	FM2-4540-000	X10 - 1	FM3-3653-000	810 - 13
FL2-9380-000	100 - 7	FM2-4540-000	X10 - 13	FM3-3654-000	810 - 13
FL2-9381-000	100 - 7	FM2-4772-000	X10 - 14	FM3-3660-000	350 -
FL2-9382-000	100 - 7	FM2-4785-000	103 - 14	FM3-3661-000	280 -
FL2-9384-000	100 - 7	FM2-4786-000	103 - 14	FM3-3662-000	250 -
FL2-9385-000	100 - 7	FM2-4788-000	103 - 14	FM3-3665-000	140 -
FL2-9386-000	100 - 7	FM2-4789-000	350 - 16	FM3-3666-000	140 - 46
FL2-9387-000	100 - 7	FM2-4792-000	210 - 36	FM3-3668-000	140 -
FL2-9388-000	100 - 7	FM2-5952-000	130 - 17	FM3-3671-000	640 -
FL2-9389-000	100 - 7	FM3-2985-000	312 - 19	FM3-3672-000	640 - 20
FM2-2753-000	130 - 13	FM3-2987-000	103 - 42	FM3-3684-000	311 -
FM2-3287-000	640 - 18	FM3-2989-000	130 - 15	FM3-3691-000	313 -
FM2-3288-000	640 - 19	FM3-2990-000	130 - 16	FM3-3695-000	102 - 14
FM2-3293-000	102 - 8	FM3-2992-000	104 - 9	FM3-3710-000	810 - 20
FM2-3294-000	315 -	FM3-2993-000	104 - 9	FM3-3711-000	350 -
FM2-3319-000	310 - 4	FM3-2994-000	104 - 9	FS1-1205-000	311 - 30
FM2-3325-000	300 - 8	FM3-2995-000	104 - 9	FS1-1205-000	313 - 43
FM2-3326-000	300 - 17	FM3-2996-000	104 - 9	FS2-1707-000	P11 - 27
FM2-3368-000	210 - 6	FM3-2997-000	104 - 9	FS2-1708-000	P31 - 17
FM2-4013-000	130 - 14	FM3-2998-000	104 - 9	FS2-1708-000	P33 - 26
FM2-4020-000	101 - 18	FM3-2999-000	104 - 9	FS2-1709-000	P33 - 27
FM2-4400-000	210 - 41	FM3-3004-000	310 - 7	FS2-1710-000	P31 - 18
FM2-4401-000	102 - 2	FM3-3005-000	104 - 13	FS2-1710-000	P33 - 28
FM2-4402-000	102 - 26	FM3-3006-000	102 - 23	FS2-1711-000	P33 - 29
FM2-4405-000	810 - 24	FM3-3007-000	103 - 41	FS2-3885-000	P33 - 22
FM2-4408-000	103 - 45	FM3-3008-000	103 - 1	FS2-3886-000	P33 - 30
FM2-4410-000	104 - 4	FM3-3010-000	104 - 11	FS2-3887-000	P33 - 31
FM2-4412-000	210 - 44	FM3-3011-000	104 - 14	FS2-9567-000	P11 - 35
FM2-4414-000	104 - 12	FM3-3012-000	312 - 23	FS2-9567-000	P33 - 32
FM2-4416-000	104 - 18	FM3-3015-000	S01 - 3	FS2-9568-000	P11 - 28
FM2-4417-000	140 - 43	FM3-3018-000	104 - 8	FS2-9569-000	P11 - 29
FM2-4418-000	210 - 10	FM3-3023-000	S20 - 41	FS2-9569-000	P12 - 14
FM2-4419-000	210 - 11	FM3-3024-000	810 - 28	FS2-9569-000	P31 - 20
FM2-4421-000	140 - 27	FM3-3319-000	900 - 1	FS2-9569-000	P33 - 33
FM2-4422-000	210 - 23	FM3-3323-000	104 - 10	FS2-9570-000	P11 - 36
FM2-4423-020	210 - 45	FM3-3324-000	900 - 3	FS2-9570-000	P33 - 51
FM2-4424-000	103 - 49	FM3-3325-000	104 - 22	FS2-9571-000	P11 - 30
FM2-4426-000	101 - 10	FM3-3327-000	900 - 2	FS2-9572-000	P12 - 15
FM2-4427-000	210 - 34	FM3-3332-000	X10 - 12	FS2-9573-000	P31 - 19
FM2-4428-000	210 - 47	FM3-3334-000	X10 - 7	FS4-0644-000	P33 - 34
FM2-4433-000	101 - 9	FM3-3526-000	810 - 25	FS4-0645-000	P33 - 23
FM2-4434-000	X10 - 5	FM3-3528-000	S20 - 30	FS4-0646-000	P33 - 35
FM2-4435-000	X10 - 9	FM3-3531-000	S20 - 36	FS4-0647-000	P33 - 36
FM2-4483-000	312 - 11	FM3-3532-000	312 - 25	FS4-0648-000	P33 - 37
FM2-4493-000	S50 -	FM3-3620-000	130 -	FS4-0649-000	P33 - 38
FM2-4500-000	312 - 27	FM3-3621-000	130 - 18	FS4-0650-000	P33 - 39
FM2-4518-000	S20 - 31	FM3-3622-000	130 -	FS4-0651-000	P33 - 40
FM2-4519-000	S20 - 32	FM3-3623-000	130 - 18	FS4-0652-000	P33 - 41

NUMERICAL INDEX

iR2030/2025/2022/2018 Series(Numerical Index)

PARTS NUMBER	FIGURE & KEY NO.	PARTS NUMBER	FIGURE & KEY NO.	PARTS NUMBER	FIGURE & KEY NO
FS4-0653-000	P33 - 42	FU5-1530-000	140 - 31	FU6-0806-000	103 - 17
FS4-0654-000	P31 - 21	FU5-1944-000	810 - 12	FU6-0814-000	140 - 33
FS4-0657-000	P12 - 16	FU5-1945-000	810 - 15	FU6-0936-000	S20 - 20
FS4-0658-000	P12 - 17	FU5-1946-000	810 - 2	FU6-0937-000	S20 - 35
FS4-0659-000	P33 - 43	FU5-2476-000	141 - 9	FU6-2146-000	102 - 18
FS4-0660-000	P33 - 44	FU5-3339-000	210 - 32	FU6-2148-000	103 - 21
FS4-2743-000	P11 - 31	FU5-3340-000	210 - 33	FU6-2149-000	103 - 22
FS4-2744-000	P33 - 45	FU5-8574-000	101 - 11	FU6-2150-000	103 - 23
FS4-2745-000	P33 - 46	FU5-8576-000	810 - 29	FU6-2151-000	103 - 24
FS4-2746-000	P33 - 21	FU5-8581-000	210 - 25	FU6-2152-000	103 - 25
FS4-2747-000	P31 - 22	FU5-8585-000	310 - 8	FU6-2156-000	103 - 28
FS4-2749-000	P33 - 52	FU5-8586-000	310 - 13	FU6-2157-000	103 - 29
FS4-2752-000	P33 - 24	FU5-8588-000	300 - 14	FU6-2158-000	103 - 30
FS4-2753-000	P33 - 47	FU5-8589-000	315 - 9	FU6-2159-000	103 - 31
FS4-2754-000	P31 - 1	FU5-8590-000	210 - 25	FU6-2160-000	140 - 44
FS5-9714-000	313 - 52	FU5-8592-000	210 - 25	FU6-2162-000	140 - 45
FS6-2917-000	300 - 20	FU5-8594-000	210 - 27	FU6-2170-000	310 - 12
FS7-0207-000	300 - 21	FU5-8595-000	210 - 27	FU6-2171-000	141 - 8
FS7-0225-000	311 - 31	FU5-8596-000	210 - 27	FU6-2173-000	141 - 10
FS7-0225-000	313 - 44	FU5-8600-000	300 - 23	FU6-2174-000	311 - 41
FS7-0226-000	311 - 32	FU5-8601-000	300 - 22	FU6-2175-000	311 - 42
FS7-0226-000	313 - 45	FU5-8601-000	300 - 22	FU6-2175-000	313 - 53
FS7-0227-000	313 - 46	FU5-8602-000	100 - 17	FU6-2176-000	103 - 16
FS7-0228-000	311 - 33	FU5-8603-000	100 - 18	FU6-2177-020	141 - 13
FS7-0228-000	313 - 47	FU5-8605-000	315 - 8	FU6-2178-000	140 - 47
FS7-0229-000	311 - 34	FU5-8607-000	140 - 1	FU6-2180-000	140 - 34
FS7-0229-000	313 - 48	FU5-8608-000	101 - 12	FU6-2181-000	140 - 35
FS7-0230-000	311 - 35	FU5-8610-000	101 - 20	FU6-2182-000	140 - 36
FS7-0230-000	313 - 49	FU5-8680-000	312 - 21	FU6-2184-000	250 - 12
FS7-8335-000	102 - 15	FU5-8696-000	S20 - 16	FU6-2188-000	810 - 23
FS9-0196-000	P01 - 6	FU5-8699-000	S01 - 7	FU6-2189-000	350 - 11
FS9-0197-000	P11 - 21	FU5-9139-000	P01 - 5	FU6-2190-000	210 - 29
FS9-0198-000	P11 - 6	FU5-9140-000	P01 - 4	FU6-2191-000	210 - 42
FS9-0201-000	P01 - 9	FU6-0762-000	640 - 21	FU6-2193-000	210 - 3
FS9-0201-000	P11 - 37	FU6-0763-000	640 - 22	FU6-2194-000	101 - 17
FS9-0202-000	P01 - 9	FU6-0764-000	640 - 23	FU6-2195-000	103 - 32
FS9-0202-000	P11 - 37	FU6-0765-000	640 - 1	FU6-2198-000	103 - 26
FS9-0203-000	P11 - 9	FU6-0766-000	250 - 5	FU6-2199-000	103 - 33
FS9-0207-000	P11 - 38	FU6-0767-000	250 - 6	FU6-2206-000	350 - 12
FS9-0208-000	P01 - 10	FU6-0770-000	311 - 37	FU6-2207-020	102 - 17
FS9-0209-000	P01 - 10	FU6-0771-000	311 - 38	FU6-2208-000	810 - 40
FS9-0210-000	P12 - 7	FU6-0773-000	141 - 12	FU6-2209-000	103 - 46
FS9-0211-000	P01 - 7	FU6-0775-000	311 - 39	FU6-2210-000	350 - 17
FS9-0211-000	P11 - 38	FU6-0776-030	311 - 40	FU6-2236-000	210 - 1
FS9-0214-000	P01 - 8	FU6-0788-000	250 - 4	FU6-2387-000	S20 - 37
FU5-0732-000	350 - 9	FU6-0790-000	250 - 7	FU6-2388-000	S20 - 38
FU5-1498-000	102 - 20	FU6-0791-000	250 - 8	FU6-8450-000	300 - 15
FU5-1499-000	102 - 21	FU6-0792-000	250 - 9	FU6-8451-000	300 - 16
FU5-1522-000	350 - 10	FU6-0793-000	250 - 10	FU6-8452-000	103 - 53
FU5-1527-000	140 - 28	FU6-0794-000	103 - 38	FU7-0923-000	311 - 36
FU5-1528-000	140 - 29	FU6-0795-000	250 - 11	FU7-0930-000	810 - 30
FU5-1529-000	140 - 30	FU6-0796-000	103 - 39	FU7-0931-000	810 - 31

NUMERICAL INDEX

iR2030/2025/2022/2018 Series(Numerical Index)

PARTS NUMBER	FIGURE & KEY NO.	PARTS NUMBER	FIGURE & KEY NO.	PARTS NUMBER	FIGURE & KEY NO
FU7-0932-000	810 - 32	WG8-5696-000	140 - 41		
FU7-0933-000	280 - 1	WG8-5696-000	210 - 43		
FU7-0934-000	280 - 2	WG8-5696-000	311 - 43		
FU7-0935-000	102 - 16	WG8-5696-000	350 - 18		
FU7-0936-000	280 - 3	WG8-5696-000	810 - 35		
FU7-0940-000	S20 - 27	WG8-5696-000	P12 - 1		
FU7-0941-000	S20 - 34	WG8-5696-000	P33 - 48		
FU7-0942-000	S20 - 42	WG8-5696-000	S20 - 39		
FU7-0943-000	S20 - 18	WG8-5696-000	X10 - 6		
FU7-0944-000	S20 - 19	WP2-5254-000	310 - 16		
FU7-2222-000	140 - 37	WS1-5792-000	X10 - 10		
FU7-2227-000	810 - 33	XA9-1116-030	S20 - 21		
FU7-2228-000	810 - 18	XA9-1415-000	210 - 22		
FU7-2229-000	810 - 27	XA9-1567-000	100 - 25		
FU7-2232-000	311 - 45	XA9-1567-000	101 - 7		
FU7-2234-000	311 - 19	XA9-1567-000	102 - 22		
FU7-2234-000	313 - 30	XA9-1567-000	103 - 50		
HK1-0559-000	X10 - 8	XA9-1567-000	104 - 16		
NPN	001 -	XA9-1567-000	210 - 46		
NPN	100 -	XD9-0133-000	311 - 23		
NPN	101 -	XD9-0133-000	313 - 37		
NPN	102 -	XD9-0134-000	810 - 14		
NPN	103 -	XD9-0136-000	140 - 42		
NPN	104 -	XD9-0136-000	210 - 35		
NPN	210 -	XD9-0136-000	311 - 24		
NPN	300 -	XD9-0136-000	312 - 18		
NPN	310 -	XD9-0136-000	313 - 38		
NPN	312 -	XD9-0136-000	810 - 37		
NPN	900 -	XD9-0136-000	S20 - 22		
NPN	C10 -	XD9-0212-000	810 - 36		
NPN	P01 -	XF2-1112-240	S20 - 40		
NPN	P11 -	XF2-1605-040	S20 - 24		
NPN	S01 -	XF2-1607-240	P33 - 50		
NPN	S20 -	XF2-1609-340	S20 - 29		
NPN	X10 -	XF2-4620-340	210 - 4		
RB2-1850-000	250 - 13	XF2-4661-440	210 - 9		
VS1-7177-002	140 - 38	XH9-0135-000	310 - 14		
VS1-7177-002	312 - 10	XH9-0135-000	312 - 28		
VS1-7177-003	102 - 27				
VS1-7177-003	140 - 39				
VS1-7177-004	140 - 40				
VS1-7177-010	104 - 6				
VS1-7207-006	104 - 19				
VS1-7207-007	104 - 20				
VS1-7207-012	S01 - 6				
VT2-5177-005	900 - 4				
WC2-5332-000	310 - 6				
WC2-5332-000	312 - 8				
WE8-5648-000	312 - 9				
WG8-5624-000	313 - 50				
WG8-5696-000	101 - 22				
WG8-5696-000	103 - 37				

iR2030/2025/2022/2018 Catalog)

Series(Parts

iR2030

230V	F18-9844-000	MXU
EUR 230V	F18-9894-000	MXW
AU 230V	F18-9894-000	MXX

iR2030i

120V	F18-9834-000	MYA
AU 230V	F18-9868-000	MYB
EUR 230V	F18-9898-000	CNG

iR2025

230V	F18-9843-000	MXP
AU 230V	F18-9864-000	MXN
EUR 230V	F18-9893-000	MXM

iR2025i

120V	F18-9833-000	MXQ
AU 230V	F18-9865-000	MXR
EUR 230V	F18-9897-000	CNF

iR2022i

120V	F18-9832-000	MXD
230V	F18-9842-000	MXG
AU 230V	F18-9863-000	MXF
EUR 230V	F18-9892-000	MXE

iR2018i

120V	F18-9831-000	MWX
230V	F18-9841-000	MXA
AU 230V	F18-9861-000	MWZ
EUR 230V	F18-9891-000	MWY

DADF-P2

A/INCH SIZE	F28-0172-000	MYD
A SIZE	F28-0173-000	MYE
A/B/INCH SIZE	F28-0174-000	MYF

Duplex Unit-B1

F28-0141-000 MYJ

Super G3 FAX Board-AA1

US	F68-0139-000
EUR	F68-0140-000
AU	F68-0141-000
ASIA	F68-0142-000
KR	F68-0144-000

Contents

A	ASSEMBLY LOCATION DIAGRAM	2-1
001	ACCESSORIES	2-6
100	EXTERNAL COVERS, PANELS, ETC.	2-8
101	MACHINE FRONT PLATE	2-12
102	INTERNAL COMPONENTS	2-14
103	INTERNAL COMPONENTS	2-16
104	MACHINE REAR PLATE	2-20
130	CONTROL PANEL ASSEMBLY	2-22
140	LEFT DOOR ASSEMBLY	2-24
141	TRANSFER MOUNT ASSEMBLY	2-28
210	READER ASSEMBLY	2-30
250	MAIN DRIVE ASSEMBLY	2-36
280	FIXING DRIVE ASSEMBLY	2-37
300	CASSETTE	2-38
310	CASSETTE FEEDER ASSEMBLY	2-40
311	PAPER PICK-UP ASSEMBLY	2-42
312	CASSETTE FEEDER ASSEMBLY(iR2030/2025/2022 Series)	2-46
313	PAPER PICK-UP ASSEMBLY(iR2030/2025/2022 Series)	2-48
315	MULTI FEED TRAY ASS'Y	2-52
350	PAPER DELIVERY ASSEMBLY	2-54
640	DEVELOPING ASSEMBLY	2-56
810	FIXING ASSEMBLY	2-58
900	IMAGE PROCESSOR PCB ASS'Y	2-61
C10	COPYBOARD COVER ASSEMBLY	2-62
P01	PACKING KIT	2-64
P11	ADF ASSEMBLY	2-66
P12	DOCUMENT TRAY ASSEMBLY	2-70
P31	OPEN/CLOSE PANEL ASSEMBLY	2-72
P33	PAPER FEEDER ASSEMBLY	2-74
S01	PACKING KIT	2-78
S20	DUPLEX FEEDER ASSEMBLY	2-80
S50	DUPLEX REVERSE UNIT	2-83
X10	FAX ASSEMBLY	2-84
ZZA	MECHANICAL STANDARD PARTS (HOW TO USE)	2-86
ZZB	MECHANICAL STANDARD PARTS (SCREWS)	2-87
ZZC	MECHANICAL STANDARD PARTS (BOLTS)	2-94
ZZD	MECHANICAL STANDARD PARTS (NUTS)	2-95
ZZE	MECHANICAL STANDARD PARTS (WASHERS)	2-96
ZZF	MECHANICAL STANDARD PARTS (RETAINING RINGS)	2-99
ZZG	MECHANICAL STANDARD PARTS (PINS)	2-102
ZZH	MECHANICAL STANDARD PARTS (SPACERS)	2-103

FIGURE A ASSEMBLY LOCATION DIAGRAM

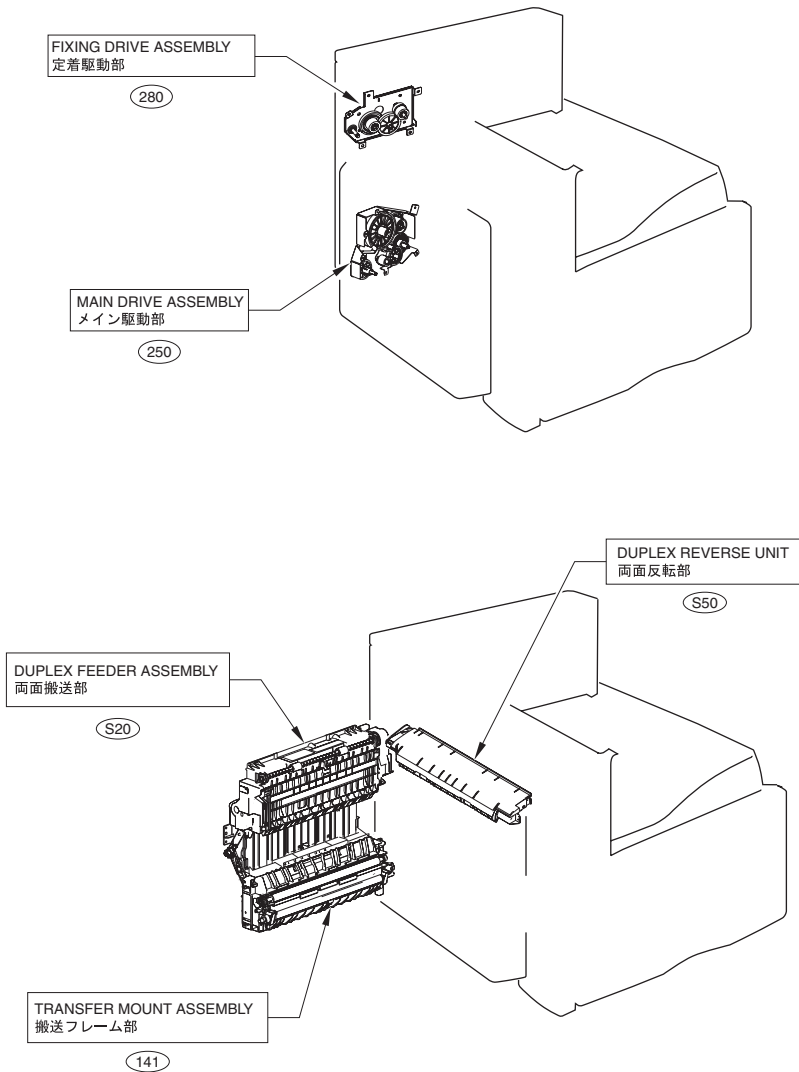

FIGURE A ASSEMBLY LOCATION DIAGRAM

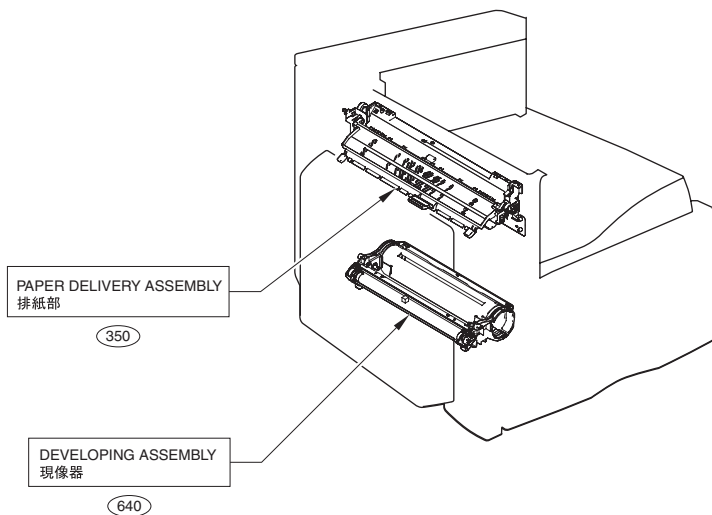
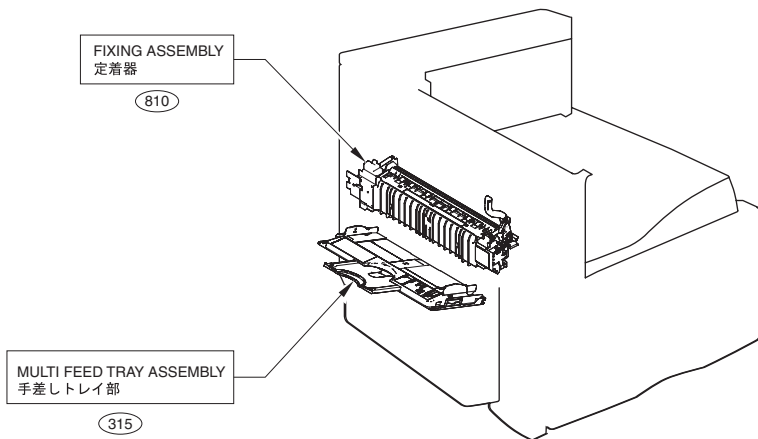
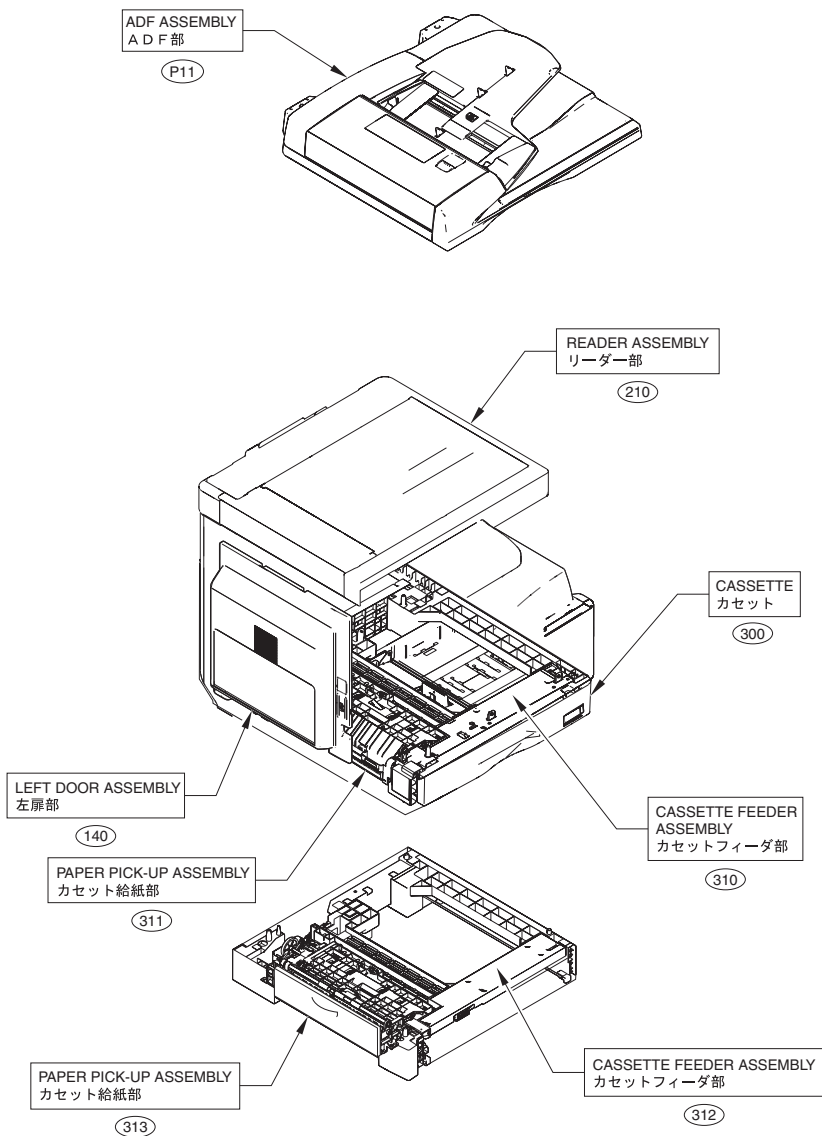

FIGURE A ASSEMBLY LOCATION DIAGRAM



No.	Model Name(English)	Model Name(Japanese)
1	DADF-P2	DADF-P2
2	INNER 2WAY TRAY-E2	インナー2ウェイトレイ・E2
3	Duplex Unit-B1	両面ユニット・B1
4	Cassette Feeding Module-P1/Q1	1段/2段カセットユニット・P1/Q1
5	FL Cassette-AF1	FLカセット・AF1
6	Cassette Size Adjuster-A1	Cassette Size Adjuster-A1
7	Cassette Heater Unit-34	Cassette Heater Unit-34
8	Cassette Heater Kit-H1	Cassette Heater Kit-H1
9	Cassette Heater Attachment Kit-E1	Cassette Heater Attachment Kit-E1
10	Serial Interface Kit-H1	Serial Interface Kit-H1
11	Super G3 FAX Board-AA1	Super G3 FAX Board-AA1
12	UFR II LT P. Kit-V1	UFR II LT P. Kit-V1
13	PCL Printer Kit-V1	PCL Printer Kit-V1
14	Serial Interface Board-A2	シリアルボードキット・A2
15	Platen Cover Type J	原稿台カバータイプJ
16	Finisher-U2	Finisher-U2
17	Additional Finisher Tray-C1	フィニッシャー用追加トレイ・C1
18	Card Reader-E1	カードリーダー・E1
19	Card Reader Attachment-D2	カードリーダー取付けキット・D2
20	Document Tray-J1	原稿置き台・J1
21	Power Supply Kit-Q1	Power Supply Kit-Q1
22	Reader Heater-D1	Reader Heater-D1

FIGURE 001 ACCESSORIES

English

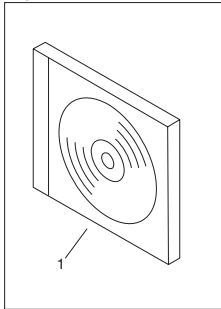

French/Spanish

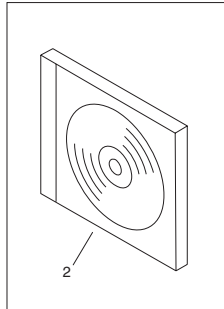

German/Italian

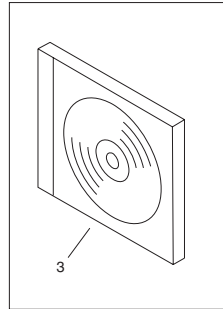

English/French/Italian/German/Spanish

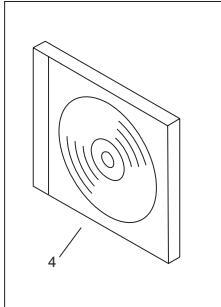

iR2018i/iR2022i/iR2025i/iR2030i AU 230V

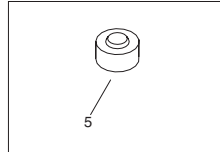

FIGURE & KEY NO.	PARTS NUMBER	RANK	Q'TY	DESCRIPTION	SERIAL NUMBER/REMARKS	SVC
Fig.001	NPN		RF	ACCESSORIES		
1	FK2-5714-000		1	CD-ROM, FAX DRIVER	English	
2	FK2-5715-000		1	CD-ROM, FAX DRIVER	French/Spanish	
3	FK2-5716-000		1	CD-ROM, FAX DRIVER	German/Italian	
4	FK2-5718-000		1	CD-ROM, FAX DRIVER	English/French/Italian/ German/Spanish	
5	FB5-9410-000		1	STAMPER	iR2018i/iR2022i/iR2025i/ iR2030i AU 230V	

FIGURE 100 EXTERNAL COVERS, PANELS, ETC.

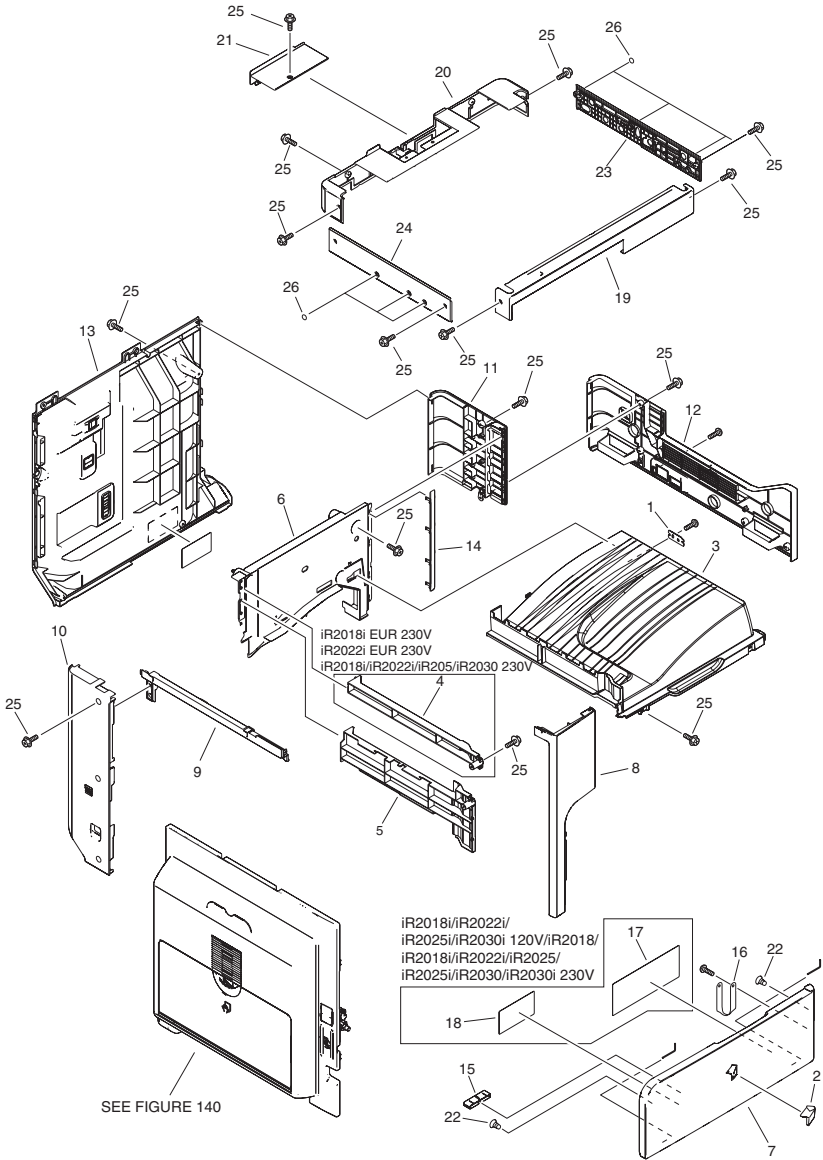

FIGURE & KEY NO.	PARTS NUMBER	R A N K	Q'TY	DESCRIPTION	SERIAL NUMBER/ REMARKS	S V C
Fig.100	NPN		RF	EXTERNAL COVERS, PANELS, ETC.		
1	FC6-4476-000		1	PLATE, SUPPORT, COVER		
2	FC6-4391-000		1	EMBLEM		
3	FC6-4259-000		1	TRAY, DELIVERY		
4	FC8-0139-000		1	COVER, PAPER FEED A	iR2018i/2022i/2025/2030 230V/iR2018i EUR 230V/iR2022i EUR 230V	
5	FC8-0140-000		1	COVER, PAPER FEED B		
6	FC6-4262-000		1	COVER, REAR, DELIVERY		
7	FL2-9379-000		1	COVER, FRONT	iR2018i 120V	
7	FL2-9380-000		1	COVER, FRONT	iR2018i 230V	
7	FL2-9381-000		1	COVER, FRONT	iR2022i 120V	
7	FL2-9382-000		1	COVER, FRONT	iR2022i 230V	
7	FL2-9384-000		1	COVER, FRONT	iR2025i 120V	
7	FL2-9385-000		1	COVER, FRONT	iR2025 230V	
7	FL2-9386-000		1	COVER, FRONT	iR2025i 230V	
7	FL2-9387-000		1	COVER, FRONT	iR2030i 120V	
7	FL2-9388-000		1	COVER, FRONT	iR2030 230V	
7	FL2-9389-000		1	COVER, FRONT	iR2030i 230V	
8	FC6-4264-000		1	COVER, LEFT, FRONT		
9	FC6-4265-000		1	COVER, LEFT, CENTER		
10	FC6-4266-000		1	COVER, REAR, LEFT		
11	FC6-4267-000		1	COVER, RIGHT, UPPER		
12	FC6-4268-000		1	COVER, RIGHT, LOWER		
13	FC6-4269-000		1	COVER, REAR		
14	FC6-4272-000		1	COVER, BLIND		
15	FC6-4271-000		1	COVER, FOOL PROOF		
16	FC6-4273-000		1	STRAP, COVER SUPPORT		
17	FU5-8602-000		1	LABEL, TONER CARTRIDGE	iR2018i/iR2022i/iR2025i/ iR2030i 120V/iR2018/ iR2018i/iR2022i/iR2025/ iR2025i/iR2030i/iR2030i 230V	

FIGURE & KEY NO.	PARTS NUMBER	RANK	Q'TY	DESCRIPTION	SERIAL NUMBER/REMARKS	SVC
18	FU5-8603-000		1	LABEL, LEVER, DEVELOPING SET	iR2018/iR2022i/iR2025/iR2030i 120ViR2018/iR2018i/iR2022i/iR2025/iR2025i/iR2030iR2030i 230V	
19	FC6-4519-000		1	COVER, READER, FRONT		
20	FC6-4529-000		1	COVER, READER, REAR		
21	FC6-4580-000		1	WINDOW, PCB		
22	FA9-3870-000		2	CATCH, MAGNET		
23	FL2-3268-000		1	COVER, READER, RIGHT		
24	FL2-3269-000		1	COVER, READER, LEFT		
25	XA9-1567-000		AR	SCREW, RS, M3X8.5		
26	FC6-4513-000		7	SEAL		

FIGURE 101 MACHINE FRONT PLATE

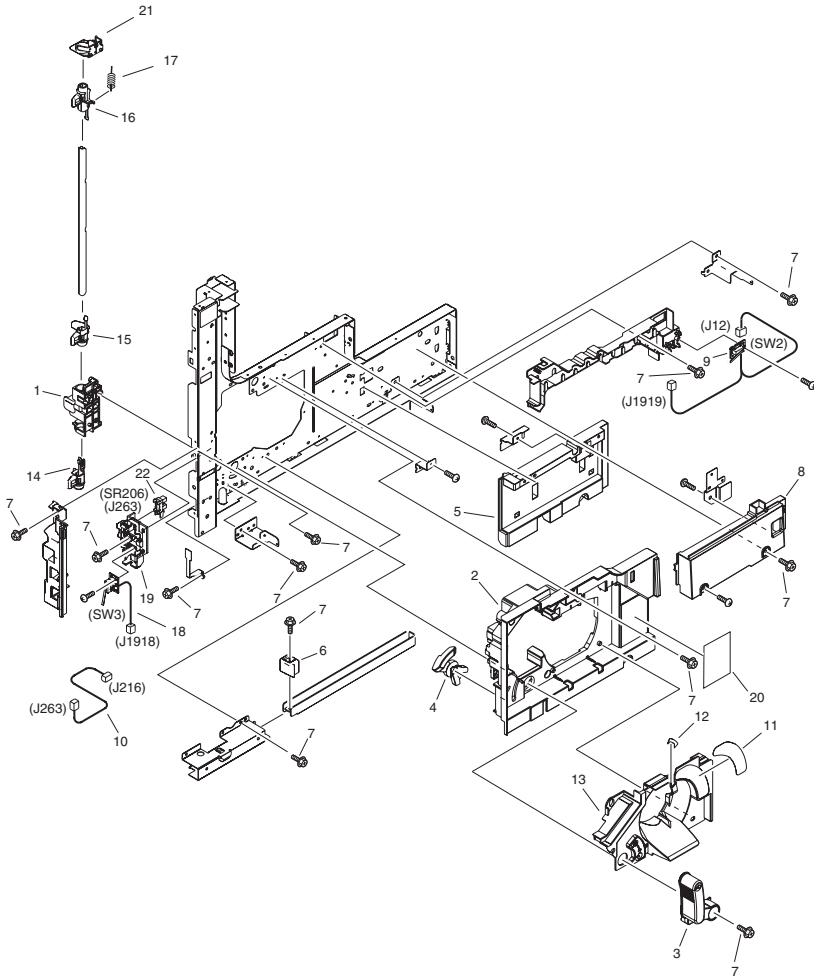

FIGURE & KEY NO.	PARTS NUMBER	R A N K	Q'TY	DESCRIPTION	SERIAL NUMBER/ REMARKS	S V C
Fig.101	NPN		RF	MACHINE FRONT PLATE		
1	FC6-4113-000		1	BUSHING, HOOK		
2	FC8-0248-000		1	PANEL, INNER		
3	FC6-4143-020		1	LEVER, DEV, PRESSURE	iR2018/iR2022i/iR2025/ iR2030i 120ViR2018/ iR2022i/iR2025i/iR2030 230V/iR2018i/iR2022i/ iR2025i/iR2025i/iR2030/ iR2030i AU230	
3	FC7-1757-020		1	LEVER, DEV, PRESSURE	iR2018i/iR2020i/iR2025/ iR2030i/iR2025i/iR2030i EUR230V	
4	FC6-4146-020		1	ARM, RELEASE, LEFT DOOR		
5	FC6-4149-000		1	PANEL, INNER, RIGHT		
6	FC6-4690-000		1	CAP, GRIP, FRONT		
7	XA9-1567-000		AR	SCREW, RS, M3X8.5		
8	FC6-7092-000		1	PANEL, INNER, UPPER		
9	FM2-4433-000		1	DOOR SWITCH PCB ASS'Y 2	SW2 J12,1919	
10	FM2-4426-000		1	CABLE, WASTE TONER DETECTION		
11	FU5-8574-000		1	LABEL, TONER BOTTLE		
12	FU5-8608-000		1	LABEL, TONER SET INSTRUCTION		
13	FC8-0249-000		1	GUIDE, TONER BOTTLE		
14	FC6-4114-000		1	HOOK, DOOR, LOWER		
15	FC6-4115-000		1	HOOK, DOOR, MIDDLE		
16	FC6-4120-000		1	HOOK, DOOR, UPPER		
17	FU6-2194-000		1	SPRING, TENSION		
18	FM2-4020-000		1	DOOR SWITCH PCB ASS'Y	SW3 J1918	
19	FC6-4147-000		1	GUIDE, SENSOR, TONER FULL		
20	FU5-8610-000		1	LABEL, CAUTION, LASER		
21	FC6-4116-000		1	BUSHING, DOOR HOOK, UPPER		
22	WG8-5696-000		1	PHOTO INTERRUPTER, TLP1243	SR206 J263	

FIGURE 102 INTERNAL COMPONENTS

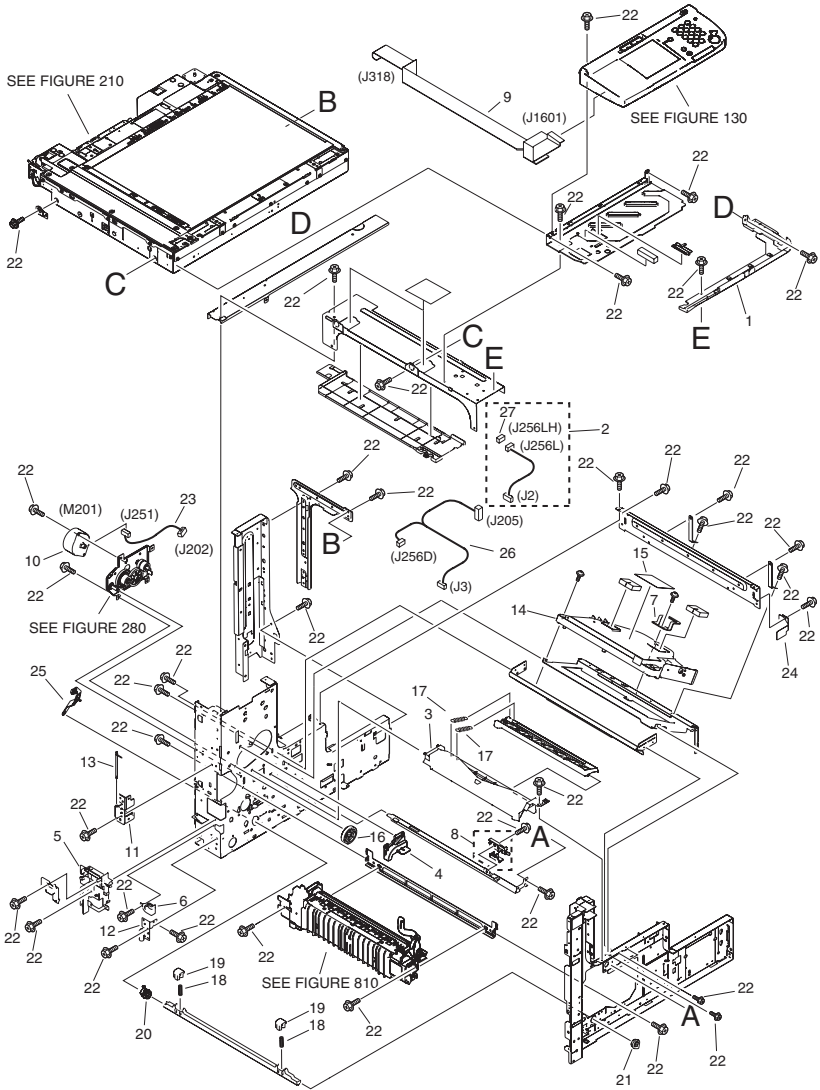

FIGURE & KEY NO.	PARTS NUMBER	R A N K	Q'TY	DESCRIPTION	SERIAL NUMBER/ REMARKS	S V C
Fig.102	NPN		RF	INTERNAL COMPONENTS		
1	FC6-4235-000		1	COVER, OPERATOR, LOWER		
2	FM2-4401-000		1	CABLE, BD		
3	FC8-0142-000		1	DUCT, AIR		
4	FC8-0214-000		1	COVER, GEAR		
5	FC6-4710-000		1	BLOCK, POSITIONING, DOOR		
6	FC6-4720-000		1	BLOCK, POSITIONING, DOOR		
7	FC6-4734-000		1	WASHER, SQUARE		
8	FM2-3293-000		1	HOOK, DRUM, ASSY		
9	FK2-1062-000		1	CABLE, FLAT, OPERATION		
10	FK2-5348-000		1	MOTOR, STEPPING, DC24V	M201	
11	FC6-4118-000		1	PLATE, HINGE, UPPER		
12	FL2-3180-000		1	PLATE, HINGE, LOWER		
13	FL2-3181-000		1	HINGE PIN UNIT		
14	FM3-3695-000		1	LASER SCANNER ASSEMBLY		
15	FS7-8335-000		1	LABEL, LASER WARNING		
16	FU7-0935-000		1	GEAR, 31T		
17	FU6-2207-020		2	SPRING, TORSION		
18	FU6-2146-000		2	SPRING, COMPRESSION		
19	FC6-4135-000		2	CAM, PRESSURE, DEV.		
20	FU5-1498-000		1	BUSHING, DEVELOPING, REAR		
21	FU5-1499-000		1	BUSHING, DEVELOPING, FRONT		
22	XA9-1567-000		AR	SCREW, RS, M3X8.5		
23	FM3-3006-000		1	CABLE, FIXING MOTOR		
24	FC6-4693-000		1	SPRING, LEAF		
25	FC6-4244-000		1	ARM, RELEASE, DEVELOPPING		
26	FM2-4402-000		1	CABLE, BD-POLYGON		
27	VS1-7177-003		1	CONNECTOR, SNAP TIGHT, BK		

FIGURE & KEY NO.	PARTS NUMBER	R A N K	Q'TY	DESCRIPTION	SERIAL NUMBER/ REMARKS	S V C
Fig.103	NPN		RF	INTERNAL COMPONENTS		
1	FM3-3008-000		1	CABLE, MAIN MOTOR		
2	FL2-8061-000		1	GUIDE, TRANSFER, UPPER		
3	FC6-4306-000		1	SPRING		
4	FC6-4311-000		1	BUSHING, TRANSFER, FRONT		
5	FC6-4312-000		1	BUSHING, TRANSFER, REAR		
6	FC6-4399-000		1	COVER, INNER, LEFT-UP		
7	FC6-4435-000		1	BUSHING		
8	FC6-4446-000		1	LID, AC-1		
9	FC6-4447-000		1	LID, AC-2		
10	FC6-4495-000		1	BUSHING		
11	FA9-2112-000		1	BUSHING, PL		
12	FK2-5350-000		1	CLUTCH, REGISTRATION	CL203 J210	
13	FK2-5355-000		1	POWER SUPPLY ASS'Y	120V	
13	FK2-5356-000		1	POWER SUPPLY ASS'Y	230V	
14	FM2-4785-000		1	CORD, POWER	120V	
14	FM2-4786-000		1	CORD, POWER	230V	
14	FM2-4788-000		1	CORD, POWER	AU 230V	
15	FL2-8066-000		1	ROLLER, REGISTRATION		
16	FU6-2176-000		1	SPRING, EARTH		
17	FU6-0806-000		1	GEAR, 17T		
18	FC6-4360-000		1	GUIDE, PRE-REGIST SENSOR		
19	FA3-8727-000		1	RING, RETAINING		
20	FC6-4148-000		1	TERMINAL, LEAF, FIXING BIAS		
21	FU6-2148-000		1	TERMINAL, CHARGE		
22	FU6-2149-000		1	TERMINAL, DEVELOPING		
23	FU6-2150-000		1	TERMINAL, DETECTION		
24	FU6-2151-000		1	TERMINAL, STATIC ELIMINATOR		
25	FU6-2152-000		1	TERMINAL, TRANSFER		
26	FU6-2198-000		1	TERMINAL, FIXING		
27	FC6-4138-000		5	TERMINAL, LEAF, HVT		
28	FU6-2156-000		1	TERMINAL, CHARGE		

FIGURE & KEY NO.	PARTS NUMBER	R A N K	Q'TY	DESCRIPTION	SERIAL NUMBER/ REMARKS	S V C
29	FU6-2157-000		1	TERMINAL, DEVELOPING		
30	FU6-2158-000		1	TERMINAL, DETECTION		
31	FU6-2159-000		1	TERMINAL, STATIC ELIMINATOR		
32	FU6-2195-000		1	TERMINAL, TRANSFER		
33	FU6-2199-000		1	TERMINAL, FIXING		
34	FC6-4308-000		1	SPRING, TORSION		
35	FC6-4309-000		1	GUIDE, PRE-REGIST, UPPER		
36	FC6-4310-000		1	FLAG, SENSOR, PRE-REGIST		
37	WG8-5696-000		1	PHOTO INTERRUPTER, TLP1243	SR209 J279	
38	FU6-0794-000		1	GEAR, 29T		
39	FU6-0796-000		1	GEAR, 33T		
40	FC6-4191-000		1	STOPPER, MULTI FEED		
41	FM3-3007-000		1	CABLE, HVT POWER		
42	FM3-2987-000		1	HVT PCB ASSEMBLY		
43	FC6-4205-000		1	SHEET, CLEANING		
44	FC6-4245-000		1	GUIDE, DEVELOPING		
45	FM2-4408-000		1	CABLE, FIXING HEATER		
46	FU6-2209-000		1	SPRING, TENSION		
47	FC6-4689-000		2	HANDLE		
48	FK2-5347-000		1	MOTOR, DC	M204	
49	FM2-4424-000		1	CABLE, RESIST SENSOR		
50	XA9-1567-000		AR	SCREW, RS, M3X8.5		
51	FC8-0336-000		2	RING, RETAINING		
52	FC6-4307-000		1	PLATE, ROLLER, REGIST		
53	FU6-8452-000		1	LABEL, JAM CLEAR		

FIGURE & KEY NO.	PARTS NUMBER	R A N K	Q'TY	DESCRIPTION	SERIAL NUMBER/ REMARKS	S V C
Fig.104	NPN		RF	MACHINE REAR PLATE		
1	FB6-1722-000		3	BUSHING, SQUARE		
2	FK2-5376-000		1	CABLE, FLAT, HVT		
3	FK2-1059-000		1	CABLE, FLAT, DC		
4	FM2-4410-000		1	CABLE, FIXING ASSEMBLY		
5	FL2-8083-000		1	COVER, IP		
6	VS1-7177-010		1	CONNECTOR, SNAP TIGHT, BK		
7	FC6-4691-000		1	CAP, GRIP, REAR		
8	FM3-3018-000		1	CABLE, ENVIRONMENT SENSOR		
9	FM3-2992-000		1	DC CONTROLLER PCB ASSEMBLY	iR2018i 120V	
9	FM3-2993-000		1	DC CONTROLLER PCB ASSEMBLY	iR2018i 230V	
9	FM3-2994-000		1	DC CONTROLLER PCB ASSEMBLY	iR2022i 120V	
9	FM3-2995-000		1	DC CONTROLLER PCB ASSEMBLY	iR2022i 230V	
9	FM3-2996-000		1	DC CONTROLLER PCB ASSEMBLY	iR2025i 120V	
9	FM3-2997-000		1	DC CONTROLLER PCB ASSEMBLY	iR2025/iR2025i 230V	
9	FM3-2998-000		1	DC CONTROLLER PCB ASSEMBLY	iR2030i 120V	
9	FM3-2999-000		1	DC CONTROLLER PCB ASSEMBLY	iR2030/iR2030i 230V	
10	FM3-3323-000		1	LAN PCB ASSEMBLY	EXCEPT iR2025/iR2030 230V	
11	FM3-3010-000		1	CABLE, SOFT ID		
12	FM2-4414-000		1	CABLE, LASER		
13	FM3-3005-000		1	CABLE, DC CONTROLLER		
14	FM3-3011-000		1	CABLE, IP-LAN	EXCEPT iR2025/iR2030 230V	
15	FL2-3229-000		1	CORE UNIT		
16	XA9-1567-000		AR	SCREW, RS, M3X8.5		
17	FC7-1749-000		1	PLATE, LEAF		
18	FM2-4416-000		1	CABLE, LEFT DOOR		
19	VS1-7207-006		1	CONNECTOR, SNAP TIGHT		
20	VS1-7207-007		1	CONNECTOR, SNAP TIGHT		
21	FK2-5122-000		1	MEMORY, USB FLASH, 128M		
22	FM3-3325-000		1	CAPACITOR PCB ASSEMBLY	EXCEPT iR2018i/iR2022i/ iR2025i/iR2030i AU 230V	

FIGURE 130 CONTROL PANEL ASSEMBLY

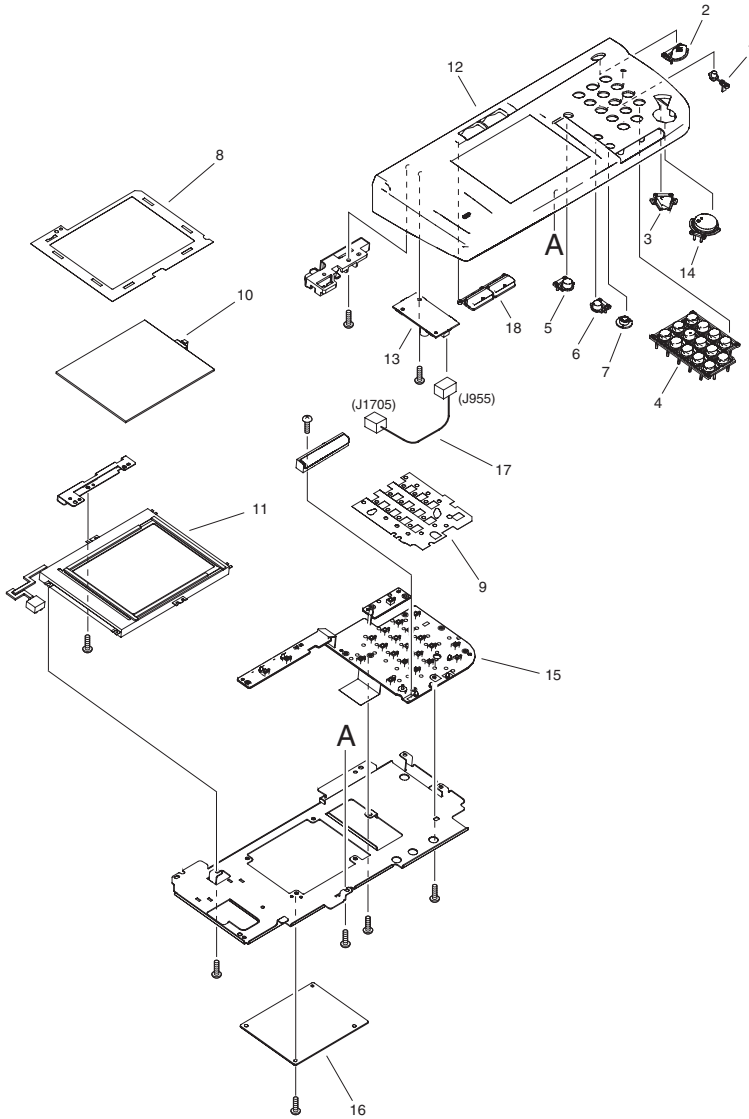
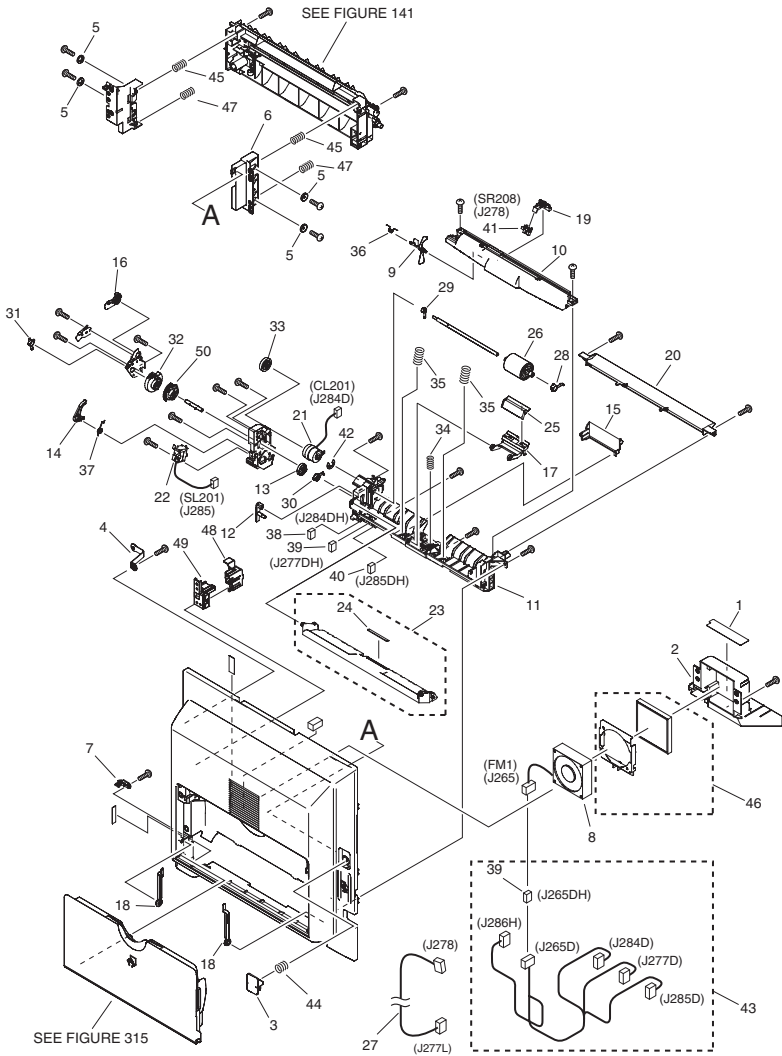

FIGURE & KEY NO.	PARTS NUMBER	R A N K	Q'TY	DESCRIPTION	SERIAL NUMBER/ REMARKS	S V C
Fig.130	FM3-3620-000		1	CONTROL PANEL ASSEMBLY	iR2018/iR2022i/iR2025/iR2030i 120ViR2018i/iR2022i/iR2025i/iR2030 230ViR2018i/iR2022i/iR2025i/iR2030i AU230	
Fig.130	FM3-3622-000		1	CONTROL PANEL ASSEMBLY	iR2018i/iR2020i/iR2025/iR2030i/iR2025i/iR2030i EUR230V	
1	FC6-5425-000		1	KEY TOP, POWER SUPPLY		
2	FC6-5426-000		1	KEY TOP, COUNTER		
3	FC6-5427-000		1	KEY TOP, STOP		
4	FC6-5428-000		1	KEY TOP, NUMBERS		
5	FC6-5429-000		1	KEY TOP, RESET		
6	FC6-5430-000		1	KEY TOP, USER MODE		
7	FC6-5431-000		1	DIAL, CONTRAST		
8	FC8-0134-000		1	SHEET, LCD		
9	FC7-1020-000		1	SHEET, ELECTROSTATIC		
10	FH6-0772-000		1	PANEL, TOUCH		
11	FL2-3463-000		1	LCD CONTROL PANEL UNIT		
12	FL2-8054-000		1	CONTROL PANEL UNIT	EXCEPT EUR 230V	
12	FL2-8055-000		1	CONTROL PANEL UNIT	EUR 230V	
13	FM2-2753-000		1	C.PANEL INVERTER PCB ASSEMBLY		
14	FM2-4013-000		1	KEY TOP, START		
15	FM3-2989-000		1	SWITCH PCB ASSEMBLY		
16	FM3-2990-000		1	CONTROL PANEL CPU PCB ASSEMBLY		
17	FM2-5952-000		1	CABLE, CPU-INVERTER		
18	FM3-3621-000		1	KEY TOP, SYSTEM	EXCEPT EUR 230V	
18	FM3-3623-000		1	KEY TOP, SYSTEM	EUR 230V	

FIGURE 140 LEFT DOOR ASSEMBLY



NOTE 1 : This assembly includes the assemblies shown in Figure 141 and 315.
 注 1 : このユニットはFigure 141, 315のユニットを含みます。

FIGURE & KEY NO.	PARTS NUMBER	RANK	Q'TY	DESCRIPTION	SERIAL NUMBER/REMARKS	SVC
Fig.140	FM3-3668-000		1	LEFT DOOR ASSEMBLY	EXCEPT iR2018i/iR2022i/iR2025i/iR2030 230V/iR2018i/iR2022i EUR 230V	
Fig.140	FM3-3665-000		1	LEFT DOOR ASSEMBLY	iR2018i/iR2022i/iR2025i/iR2030 230V/iR2018i/iR2022i EUR 230V	
1	FU5-8607-000		1	LABEL, WARNING, ROLLER		
2	FC8-0232-000		1	HOLDER, FAN		
3	FC6-4386-000		1	BUTTON, PUSH		
4	FC6-4388-000		1	STOPPER, DOOR		
5	FC6-4413-000		4	SPACER, FRAME, FEED		
6	FC6-4414-000		1	MOUNT, FRAME, FEED		
7	FC6-7103-000		1	BLOCK, COVER		
8	FK2-5368-000		1	FAN	FM1 J265	
9	FC6-4209-020		1	FLAG, SENSOR		
10	FC6-4210-000		1	COVER, ROLLER		
11	FC6-4211-000		1	GUIDE, MULTI FEED		
12	FC6-4224-000		1	SUPPORT, CAM, LIFTING		
13	FC8-0168-000		1	CAM, LIFTING PLATE		
14	FC6-4227-020		1	ARM, MULTI FEED		
15	FC6-4232-000		1	COVER, HARNESS		
16	FC8-0167-000		1	STOPPER, SWING PLATE		
17	FC6-4234-000		1	ARM, PAD, SEPARATION		
18	FC6-4238-000		2	STOPPER, MULTI FEED		
19	FC6-4239-000		1	HOLDER, SENSOR		
20	FC6-4377-000		1	GUIDE, FEED		
21	FK2-1070-000		1	CLUTCH, ELECTROMAGNETIC	CL201 J284D	
22	FK2-1072-000		1	SOLENOID	SL201 J285	
23	FL2-3200-000		1	LIFTING PLATE ASSEMBLY		
24	FC5-0543-000		1	SHEET, SEPARATION		
25	FL2-3201-000		1	SEPARATION PAD ASSY		
26	FL2-3202-000		1	ROLLER, PICK-UP		
27	FM2-4421-000		1	HARNESS, SENSOR, PAPER		

FIGURE & KEY NO.	PARTS NUMBER	R A N K	Q'TY	DESCRIPTION	SERIAL NUMBER/ REMARKS	S V C
28	FU5-1527-000		1	BUSHING, ROLLER, PICK-UP		
29	FU5-1528-000		1	BUSHING, SHAFT, PICK-UP		
30	FU5-1529-000		1	BUSHING, SHAFT, CAM (F)		
31	FU5-1530-000		1	BUSHING, SHAFT, CAM (R)		
32	FC8-0165-000		1	GEAR, MULTI FEED		
33	FU6-0814-000		1	GEAR, 25T		
34	FU6-2180-000		1	SPRING, COMPRESSION		
35	FU6-2181-000		2	SPRING, COMPRESSION		
36	FU6-2182-000		1	SPRING, TORSION		
37	FU7-2222-000		1	SPRING, TORSION		
38	VS1-7177-002		1	CONNECTOR, SNAP TIGHT, BK		
39	VS1-7177-003		2	CONNECTOR, SNAP TIGHT, BK		
40	VS1-7177-004		1	CONNECTOR, SNAP TIGHT, BK		
41	WG8-5696-000		1	PHOTO INTERRUPTER, TLP1243	SR208 J278	
42	XD9-0136-000		1	RING, E		
43	FM2-4417-000		1	CABLE, LEFT DOOR		
44	FU6-2160-000		1	SPRING, COMPRESSION		
45	FU6-2162-000		2	SPRING, COMPRESSION		
46	FM3-3666-000		1	FILTER UNIT		
47	FU6-2178-000		2	SPRING, COMPRESSION		
48	FC8-0320-000		1	HOLDER, DUPLEX CONNECTOR,UP.		
49	FC8-0321-000		1	HOLDER, DUPLEX CONNECTOR,LO.		
50	FC8-0166-000		1	GEAR, 39T		

FIGURE 141 TRANSFER MOUNT ASSEMBLY

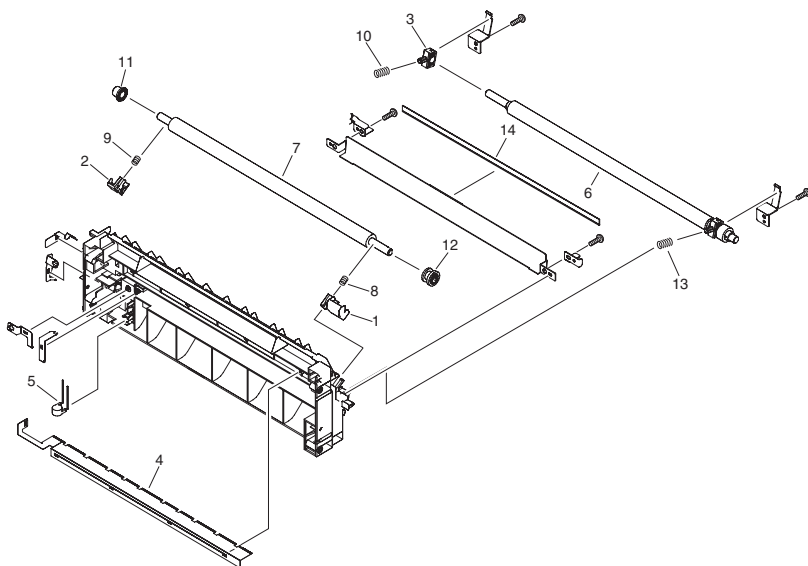

NOTE : This assembly is included in the assembly shown in Figure 140.
注 : このユニットはFigure 140のユニットに含まれます。

FIGURE & KEY NO.	PARTS NUMBER	R A N K	Q'TY	DESCRIPTION	SERIAL NUMBER/ REMARKS	S V C
Fig.141	FM3-3640-000		1	TRANSFER MOUNT ASSEMBLY	SEE NOTE	
1	FC6-4314-000		1	BUSHING, TRANSFER, FRONT		
2	FC6-4315-000		1	BUSHING, TRANSFER, LOWER		
3	FC6-4317-000		1	BUSHING, REGIST ROLLER		
4	FC6-4324-000		1	ELIMINATOR, STATIC CHARGE		
5	FH5-3543-000		1	VARISTOR		
6	FL2-8063-000		1	REGIST ROLLER ASSEMBLY		
7	FC6-4313-000		1	ROLLER, TRANSFER		
8	FU6-2171-000		1	SPRING, TRANSFER ROLLER, LEFT		
9	FU5-2476-000		1	SPRING, TRANSFER ROLLER, RIGHT		
10	FU6-2173-000		1	SPRING, COMPRESSION		
11	FC6-4316-000		1	ROLLER		
12	FU6-0773-000		1	GEAR, 30T		
13	FU6-2177-020		1	SPRING, COMPRESSION		
14	FC8-0340-000		1	SHEET, STATIC CHARGE		

FIGURE 210 READER ASSEMBLY

iR2018i/iR2022i/iR2025i/iR2030i 120V
 iR2018i/iR2022i/ 230V
 iR2018i/iR2022i/iR2025i/iR2030i AU 230V
 iR2018i/iR2022i/iR2025i/iR2030i EUR 230V

iR2025i/iR2030 230V
 iR2025i/iR2030 AU 230V
 iR2025i/iR2030 EUR 230V

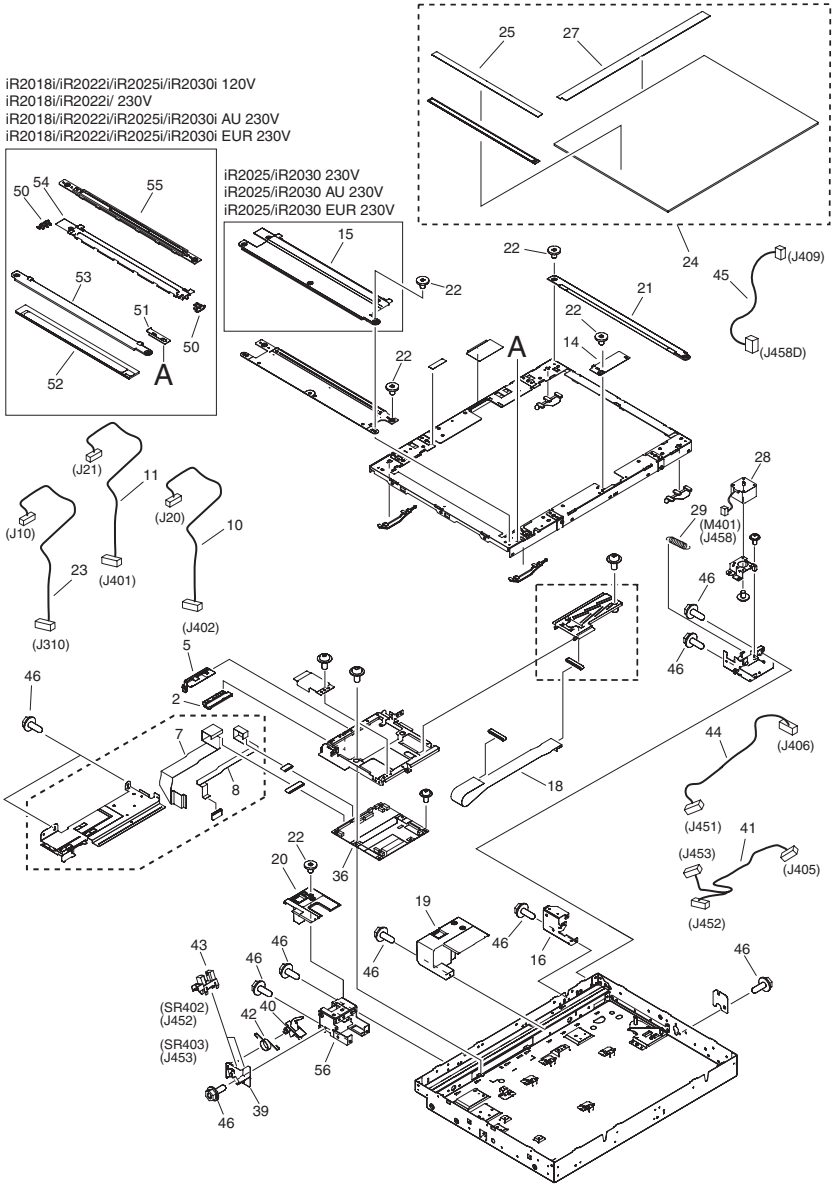

FIGURE 210 READER ASSEMBLY

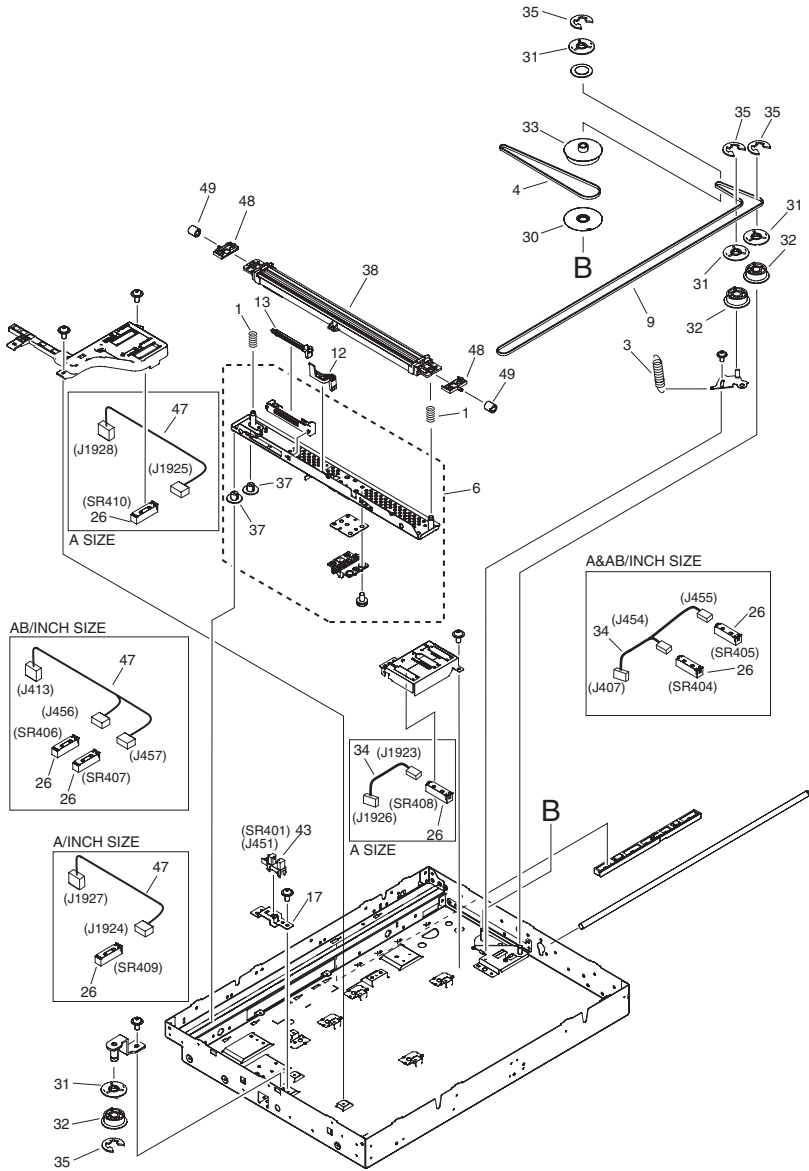

FIGURE & KEY NO.	PARTS NUMBER	RANK	Q'TY	DESCRIPTION	SERIAL NUMBER/REMARKS	SVC
Fig.210	NPN		RF	READER ASSEMBLY		
1	FU6-2236-000		2	SPRING, COMPRESSION		
2	FC6-4522-000		1	HOLDER, CORE		
3	FU6-2193-000		1	SPRING, TENSION		
4	XF2-4620-340		1	BELT, TIMING		
5	FC6-4582-000		1	CLAMP,FLEXIBLE		
6	FM2-3368-000		1	CARRIAGE UNIT		
7	FK2-1060-000		1	CABLE, FLAT, READER 1		
8	FK2-1064-000		1	CABLE, FLAT, READER 2		
9	XF2-4661-440		1	BELT, TIMING		
10	FM2-4418-000		1	CABLE, READER CONTROLLER 1		
11	FM2-4419-000		1	CABLE, READER CONTROLLER 2		
12	FC5-0792-000		1	RETAINER, BELT		
13	FC5-1444-000		1	HOLDER, FFC		
14	FC6-4528-000		1	LID, GRASS RETAINER		
15	FC6-4541-000		1	COVER, LEFT, UPPER	iR2025/iR2030 230V/iR2025/iR2030 AU 230V/iR2025/iR2030 EUR 230V	
16	FC6-4573-000		1	PLATE, HINGE, RIGHT		
17	FC6-4727-000		1	HOLDER, SENSOR		
18	FK2-1061-000		1	CABLE, FLAT, READER		
19	FC6-4562-000		1	COVER, HINGE, RIGHT		
20	FC6-4558-000		1	COVER, HINGE, LEFT		
21	FL2-3230-000		1	RETAINER, GLASS (R)		
22	XA9-1415-000		12	SCREW, FLAT HEAD, M4		
23	FM2-4422-000		1	CABLE, READER CONTROLLER		
24	FL2-3206-000		1	GLASS, COPYBOARD	iR2018/iR2022i/iR2025/ iR2030 230V/iR2018i/ iR2022i/iR2025i/iR2025i/ iR2030i/iR2030i AU 230V	
24	FL2-3207-000		1	GLASS, COPYBOARD	iR2018i/iR2022i/iR2025i/ iR2030i 120V	
24	FL2-3208-000		1	GLASS, COPYBOARD	iR2018i/iR2022i/iR2025/ iR2030i/iR2025i/iR2030i EUR 230	

FIGURE & KEY NO.	PARTS NUMBER	R A N K	Q'TY	DESCRIPTION	SERIAL NUMBER/ REMARKS	S V C
25	FU5-8592-000		1	PLATE, WIDTH INDEX	A/INCH SIZE	
25	FU5-8581-000		1	PLATE, WIDTH INDEX	A SIZE	
25	FU5-8590-000		1	PLATE, WIDTH INDEX	A/B/INCH SIZE	
26	FH7-7569-000		3	DOCUMENT SIZE SENSOR UNIT	iR2022i/iR2025i/iR2030i 120VSR404,405,407,409	
26	FH7-7569-000		2	DOCUMENT SIZE SENSOR UNIT	iR2022i/iR2025i/iR2030/ iR2025i/iR2030i 230VSR408,410	
26	FH7-7569-000		4	DOCUMENT SIZE SENSOR UNIT	iR2022i/iR2025i/iR2030/ iR2025i/iR2030i EUR 230VSR404,405,406,407	
27	FU5-8595-000		1	PLATE, LENGTH INDEX	A/INCH SIZE	
27	FU5-8596-000		1	PLATE, LENGTH INDEX	A SIZE	
27	FU5-8594-000		1	PLATE, LENGTH INDEX	A/B/INCH SIZE	
28	FK2-1066-020		1	MOTOR, STEPPING	M401 J458	
29	FU6-2190-000		1	SPRING, TENSION		
30	FC6-4506-000		1	FLANGE		
31	FC6-4514-000		4	FLANGE		
32	FU5-3339-000		3	PULLEY		
33	FU5-3340-000		1	PULLEY		
34	FM2-4427-000		1	CABLE, DOCUMENT SIZE SENSOR	iR2022i/iR2025i/iR2030i 120ViR2022i/iR2025i/ iR2030 230ViR2022i/ iR2025i/iR2025i/iR2030/ iR2030i AU 230VJ407,454,455	
34	FM2-4535-000		1	CABLE, DOCUMENT SIZE SENSOR	iR2022i/iR2025i/iR2030/ iR2025i/iR2030i EUR 230VJ1923,1926	
35	XD9-0136-000		4	RING, E		
36	FM2-4792-000		1	READER CONTROLLER PCB ASSEMBLY		
37	FC6-4511-000		2	SLIDER		
38	FL2-3286-000		1	CONTACT IMAGE SENSOR		
39	FC6-4559-000		1	HOLDER, SENSOR		
40	FC6-4561-000		1	LEVER, SENSOR		
41	FM2-4400-000		1	CABLE, SENSOR		
42	FU6-2191-000		1	SPRING, SENSOR		

FIGURE & KEY NO.	PARTS NUMBER	R A N K	Q'TY	DESCRIPTION	SERIAL NUMBER/ REMARKS	S V C
43	WG8-5696-000		3	PHOTO INTERRUPTER, TLP1243	SR401,402,403 J451,452,453	
44	FM2-4412-000		1	CABLE, HP SENSOR		
45	FM2-4423-020		1	CABLE, READER MOTOR		
46	XA9-1567-000		38	SCREW, RS, M3X8.5		
47	FM2-4536-000		1	CABLE, DOCUMENT SIZE SENSOR	iR2022i/iR2025i/iR2030i 120VJ1924,1927	
47	FM2-4537-000		1	CABLE, DOCUMENT SIZE SENSOR	iR2022i/iR2025i/iR2030/ iR2025i/iR2030i EUR 230VJ1925,1928	
47	FM2-4428-000		1	CABLE, DOCUMENT SIZE SENSOR	iR2022i/iR2025i/iR2030 230ViR2022i/iR2025/ iR2025i/iR2030i/iR2030i AU 230J413,456,457	
48	FB6-1336-000		2	GUIDE, CIS		
49	FB6-1337-000		2	COLLAR		
50	FC5-1427-000		2	COVER, EDGE	iR2018i/iR2022i/iR2025i/ iR2030i 120ViR2018i/ iR2022i/ 230ViR2018i/ iR2022i/iR2025i/iR2030i AU 230ViR2018i/iR2022i/ iR2025i/iR2030i EUR 230V	
51	FC6-4525-000		1	RETAINER, GLASS	iR2018i/iR2022i/iR2025i/ iR2030i 120ViR2018i/ iR2022i/ 230ViR2018i/ iR2022i/iR2025i/iR2030i AU 230ViR2018i/iR2022i/ iR2025i/iR2030i EUR 230V	
52	FL2-3188-000		1	GLASS, READER	iR2018i/iR2022i/iR2025i/ iR2030i 120ViR2018i/ iR2022i/ 230ViR2018i/ iR2022i/iR2025i/iR2030i AU 230ViR2018i/iR2022i/ iR2025i/iR2030i EUR 230V	
53	FL2-3231-000		1	RETAINER, GLASS, LEFT	iR2018i/iR2022i/iR2025i/ iR2030i 120ViR2018i/ iR2022i/ 230ViR2018i/ iR2022i/iR2025i/iR2030i AU 230ViR2018i/iR2022i/ iR2025i/iR2030i EUR 230V	

FIGURE & KEY NO.	PARTS NUMBER	RANK	Q'TY	DESCRIPTION	SERIAL NUMBER/REMARKS	SVC
54	FL2-3233-000		1	GUIDE, PAPER	iR2018i/iR2022i/iR2025i/iR2030i 120ViR2018i/iR2022i/ 230ViR2018i/iR2022i/iR2025i/iR2030i AU 230ViR2018i/iR2022i/iR2025i/iR2030i EUR 230V	
55	FC5-1452-000		1	CROSSMEMBER, GLASS	iR2018i/iR2022i/iR2025i/iR2030i 120ViR2018i/iR2022i/ 230ViR2018i/iR2022i/iR2025i/iR2030i AU 230ViR2018i/iR2022i/iR2025i/iR2030i EUR 230V	
56	FC6-4560-000		1	PLATE, HINGE, LEFT		

FIGURE 250 MAIN DRIVE ASSEMBLY

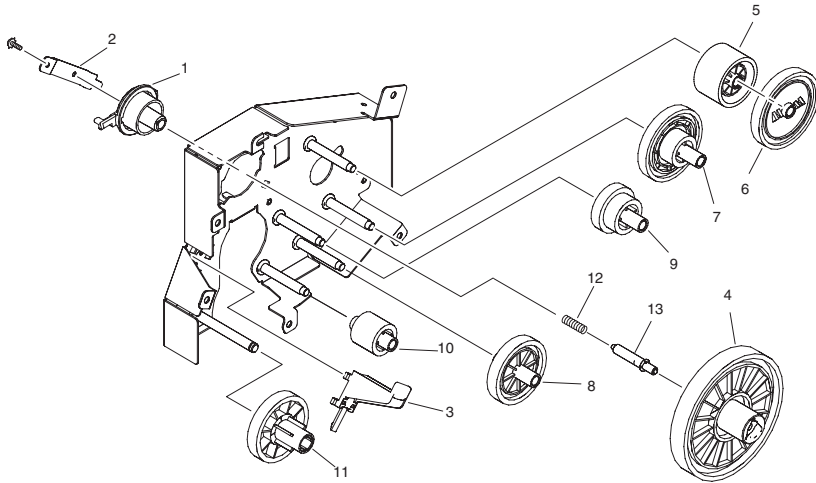

FIGURE & KEY NO.	PARTS NUMBER	RANK	QTY	DESCRIPTION	SERIAL NUMBER/REMARKS	SVC
Fig.250	FM3-3662-000		1	MAIN DRIVE ASSEMBLY		
1	FC6-4436-000		1	BUSHING		
2	FC6-4437-000		1	PLATE, EARTH		
3	FC6-4497-000		1	STOPPER, GEAR		
4	FU6-0788-000		1	GEAR, 161T		
5	FU6-0766-000		1	GEAR, 13T		
6	FU6-0767-000		1	GEAR, 9T		
7	FU6-0790-000		1	GEAR, 25T/91T		
8	FU6-0791-000		1	GEAR, 53T		
9	FU6-0792-000		1	GEAR, 37T/28T		
10	FU6-0793-000		1	GEAR, 25T		
11	FU6-0795-000		1	GEAR, 55T		
12	FU6-2184-000		1	SPRING, EARTH		
13	RB2-1850-000		1	PIN		

FIGURE 280 FIXING DRIVE ASSEMBLY

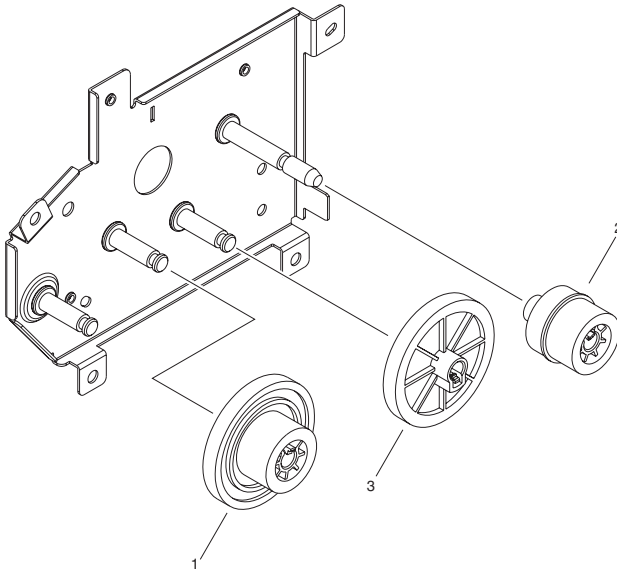

FIGURE & KEY NO.	PARTS NUMBER	RANK	Q'TY	DESCRIPTION	SERIAL NUMBER/REMARKS	SVC
Fig.280	FM3-3661-000		1	FIXING DRIVE ASSEMBLY		
1	FU7-0933-000		1	GEAR, 82T/17T		
2	FU7-0934-000		1	GEAR, 20T/17T		
3	FU7-0936-000		1	GEAR, 35T		

FIGURE 300 CASSETTE

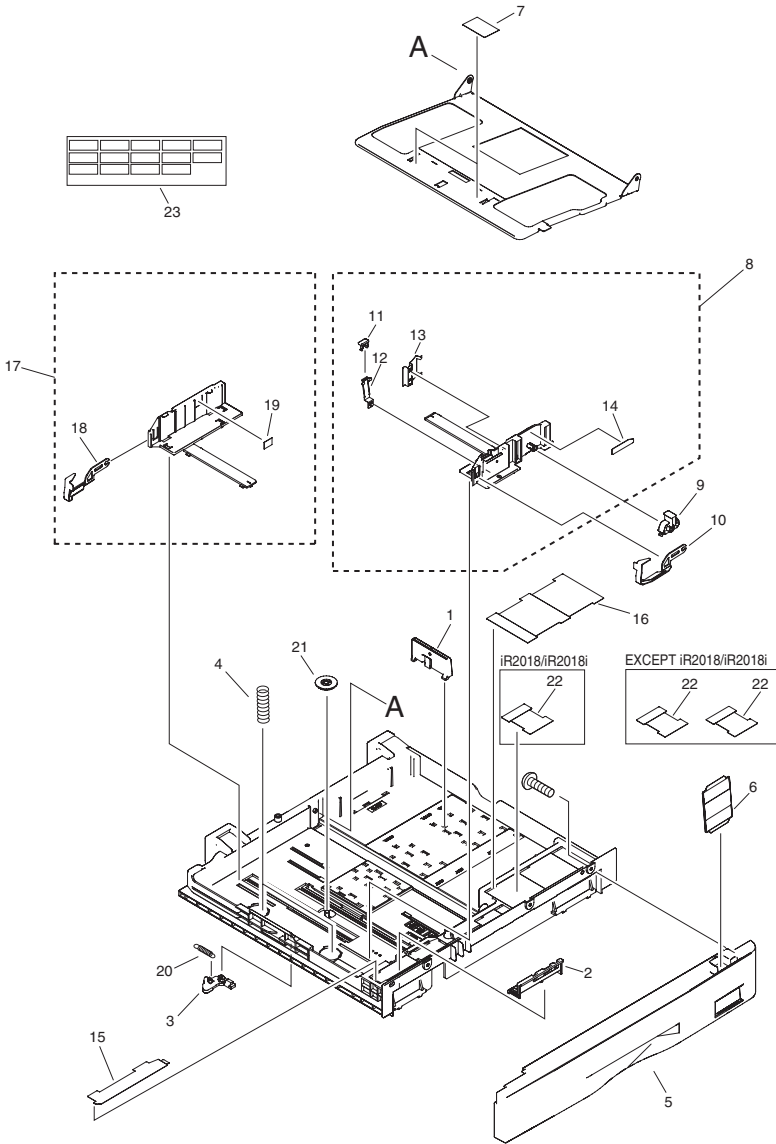

FIGURE & KEY NO.	PARTS NUMBER	R A N K	Q'TY	DESCRIPTION	SERIAL NUMBER/ REMARKS	S V C
Fig.300	NPN		RF	CASSETTE		
1	FB4-5814-000		1	PLATE, SIZE, REAR		
2	FB6-1640-000		1	LEVER, PAPER SIZE		
3	FB6-1644-000		1	LOCK, PAPER LIFTING PLATE		
4	FB6-2000-000		2	SPRING, COMPRESSION		
5	FC6-4337-000		1	COVER, CASSETTE		
6	FC6-4361-000		1	PLATE, SIZE INDICATOR		
7	FB6-1650-000		2	SHEET, SEPARATION		
8	FM2-3325-000		1	PAPER SIDE GUIDE (F) UNIT		
9	FB4-5809-020		1	LEVER, LOCK		
10	FB4-5813-020		1	PLATE, HOLD-DOWN TAB		
11	FB4-5810-000		1	PLATE, PAPER CONTACT		
12	FB6-1646-000		1	SPRING, LEAF		
13	FB6-1649-000		1	SPRING, LEAF		
14	FU5-8588-000		1	LABEL, SIDE LOCK		
15	FU6-8450-000		1	SHEET, PAPER SIZE SETTING		
16	FU6-8451-000		1	SHEET, PAPER SUPPLY		
17	FM2-3326-000		1	PAPER SIDE GUIDE (R) UNIT		
18	FB4-5808-020		1	PLATE, HOLD-DOWN TAB		
19	FB4-5824-000		1	LABEL, LIMIT		
20	FS6-2917-000		1	SPRING, TENSION		
21	FS7-0207-000		1	GEAR, 20T		
22	FU5-8601-000		1	SHEET, WARNING	iR2018/iR2018i	
22	FU5-8601-000		2	SHEET, WARNING	EXCEPT iR2018/iR2018i	
23	FU5-8600-000		1	LABEL, PAPER SIZE		

FIGURE & KEY NO.	PARTS NUMBER	RANK	Q'TY	DESCRIPTION	SERIAL NUMBER/REMARKS	SVC
Fig.310	NPN		RF	CASSETTE FEEDER ASSEMBLY		
1	FB4-5532-000		1	DAMPER		
2	FB6-1608-000		1	HOLDER, DAMPER		
3	FC6-4357-000		1	BLOCK, POSITION		
4	FM2-3319-000		1	SIZE DETECTION ASS'Y		
5	FB6-1910-000		1	MOUNT, SIZE SENSOR		
6	WC2-5332-000		1	SWITCH, PAPER SIZE	SW4,J262	
7	FM3-3004-000		1	CABLE, CASSETTE		
8	FU5-8585-000		1	LABEL, JAM CLEARING		
9	FC6-4297-000		4	BUSHING, ROLLER, VERTICAL		
10	FC6-4298-000		1	COVER, CASSETTE, LEFT		
11	FC6-4300-000		2	ROLLER, VERTICAL PASS		
12	FU6-2170-000		4	SPRING, COMPRESSION		
13	FU5-8586-000		1	LABEL, COVER		
14	XH9-0135-000		2	FOOT, RUBBER		
15	FM3-3643-000		1	PLATE, EARTH	EXCEPT iR2018/iR2018i	
16	WP2-5254-000		1	SENSOR, HUMIDITY		

FIGURE & KEY NO.	PARTS NUMBER	R A N K	Q'TY	DESCRIPTION	SERIAL NUMBER/ REMARKS	S V C
Fig.311	FM3-3684-000		1	PAPER PICK-UP ASSEMBLY		
1	FB6-1550-000		1	SPRING, TENSION		
2	FB6-1626-000		1	LEVER, COUPLING		
4	FB6-1660-000		1	CAM		
5	FB6-1909-000		1	BUSHING		
6	FC8-0256-000		1	GUIDE, TURN		
7	FC8-0164-000		1	ROLLER, VERTICAL PASS		
8	FC6-4291-000		1	BUSHING, CLUTCH		
9	FC6-4304-000		2	BUSHING, ROLLER, PICK-UP		
10	FC6-4326-000		2	LOCK, VERTICAL PASS		
11	FC8-0158-000		1	BUSHING, CLUTCH, REAR		
12	FC6-4350-000		1	ARM, DETECTION, PAPER		
13	FC6-4352-000		1	COLLAR, SPRING		
14	FC6-4355-000		1	BUSHING		
15	FC6-4358-000		1	JOINT, RETARD		
16	FF6-1621-000		2	ROLLER, SEPARATION		
17	FK2-5367-000		1	CLUTCH, ELECTROMAGNETIC		
18	FK2-1082-000		1	SOLENOID		
19	FU7-2234-000		1	SPRING, TORSION		
20	FB6-1908-000		1	CAP		
21	FC6-4290-000		1	LIMITER, TORQUE		
22	FL2-3212-000		1	BUSHING		
23	XD9-0133-000		1	RING, E		
24	XD9-0136-000		3	RING, E		
25	FB4-9817-030		2	ROLLER, PICK-UP		
26	FC6-4284-000		1	SHAFT, ROLLER, PICK-UP		
27	FC6-4351-000		1	SHAFT, ROLLER		
28	FC6-4356-000		2	ROLLER, LOOP		
29	FE5-4048-000		2	BLOCK, PICK-UP ROLLER ADPTER		
30	FS1-1205-000		4	BUSHING		
31	FS7-0225-000		1	GEAR, 53T		
32	FS7-0226-000		1	GEAR, 36T		

FIGURE & KEY NO.	PARTS NUMBER	RANK	Q'TY	DESCRIPTION	SERIAL NUMBER/REMARKS	SVC
33	FS7-0228-000		1	GEAR, 31T		
34	FS7-0229-000		1	GEAR, 18T		
35	FS7-0230-000		1	GEAR, 27T		
36	FU7-0923-000		1	GEAR, 17T		
37	FU6-0770-000		1	GEAR, 21T/37T/22T		
38	FU6-0771-000		1	GEAR, 16T/34T		
39	FU6-0775-000		1	GEAR, 39T		
40	FU6-0776-030		1	GEAR, 29T		
41	FU6-2174-000		2	SPRING, TENSION		
42	FU6-2175-000		1	SPRING, TORSION		
43	WG8-5696-000		1	PHOTO INTERRUPTER, TLP1243	SR6 J755	
44	FC7-1770-000		1	BUSHING		
45	FU7-2232-000		1	SPRING, TORSION		
46	FC8-0257-000		1	FLAG, SEPARATION SENSOR		
47	FC6-4288-020		1	LEVER, PRESSURE		

FIGURE 312 CASSETTE FEEDER ASSEMBLY(iR2030/2025/2022 Series)

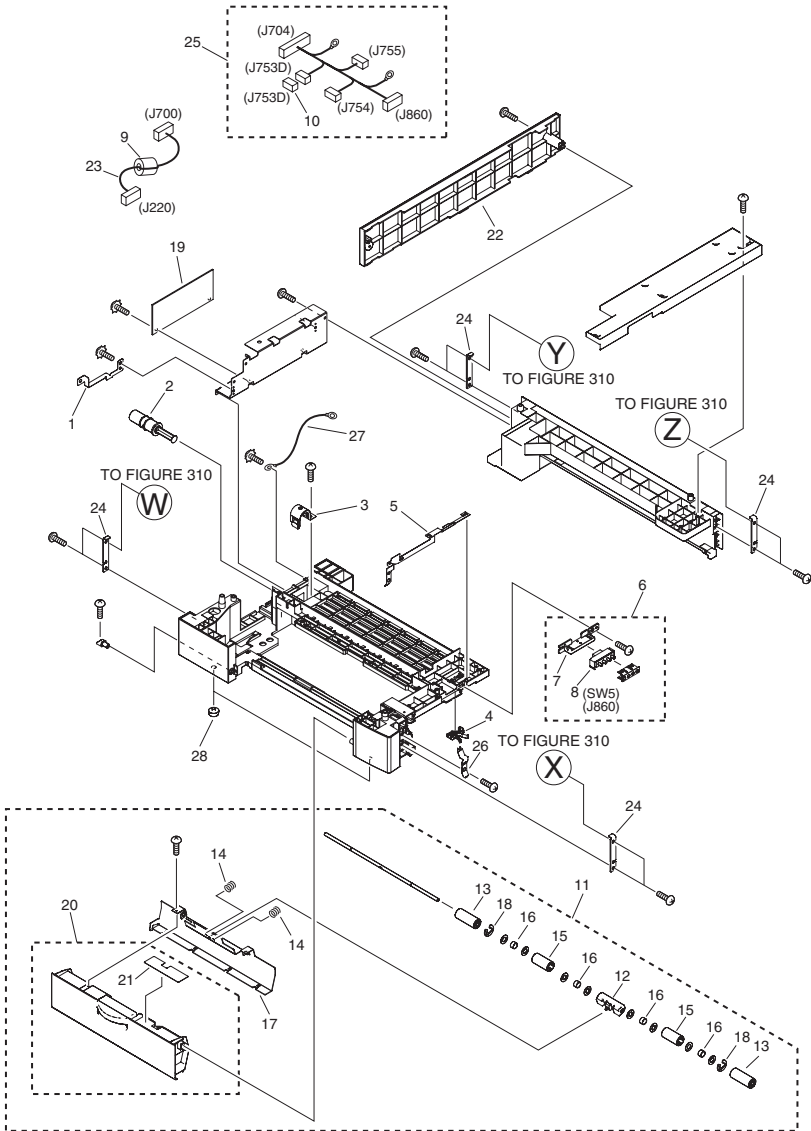

FIGURE & KEY NO.	PARTS NUMBER	RANK	Q'TY	DESCRIPTION	SERIAL NUMBER/REMARKS	SVC
Fig.312	NPN		RF	CASSETTE FEEDER ASSEMBLY	EXCEPT iR2018/iR2018i	
1	FC6-6720-000		1	PLATE, GROUNDING		
2	FB4-5532-000		1	DAMPER		
3	FB6-1608-000		1	HOLDER, DAMPER		
4	FC6-4357-000		1	BLOCK, POSITION		
5	FC6-6706-000		1	PLATE, EARTH		
6	FG6-8440-000		1	SIZE SENSOR UNIT		
7	FB6-1910-000		1	MOUNT, SIZE SENSOR		
8	WC2-5332-000		1	SWITCH, PAPER SIZE	SW5,J860	
9	WE8-5648-000		1	CORE, SLEEVE FERRITE		
10	VS1-7177-002		1	CONNECTOR, SNAP TIGHT, BK		
11	FM2-4483-000		1	VERTICAL PATH UNIT		
12	FA8-2447-000		1	MOUNT, ROLLER		
13	FB6-1536-000		2	ROLLER		
14	FB6-1920-000		2	SPRING, COMPRESSION		
15	FB6-1996-000		2	ROLLER, VERTICAL PATH		
16	FB6-1997-000		4	SPRING, COMPRESSION		
17	FC6-6714-000		1	GUIDE, VERTICAL PATH		
18	XD9-0136-000		2	RING, E		
19	FM3-2985-000		1	FEEDER CONTROLLER PCB ASS'Y		
20	FL2-3736-000		1	COVER, VERTICAL PATH		
21	FU5-8680-000		1	LABEL,JAM		
22	FC6-6710-000		1	COVER, CASSETTE, REAR		
23	FM3-3012-000		1	CABLE, INTERFACE, 1		
24	FC6-6707-000		4	PLATE, JOINT		
25	FM3-3532-000		1	CABLE, FEEDER		
26	FC6-6712-000		1	PLATE, EARTH		
27	FM2-4500-000		2	CABLE, EARTH		
28	XH9-0135-000		2	FOOT, RUBBER		

FIGURE 313
PAPER PICK-UP ASSEMBLY (iR2030/2025/2022 Series)

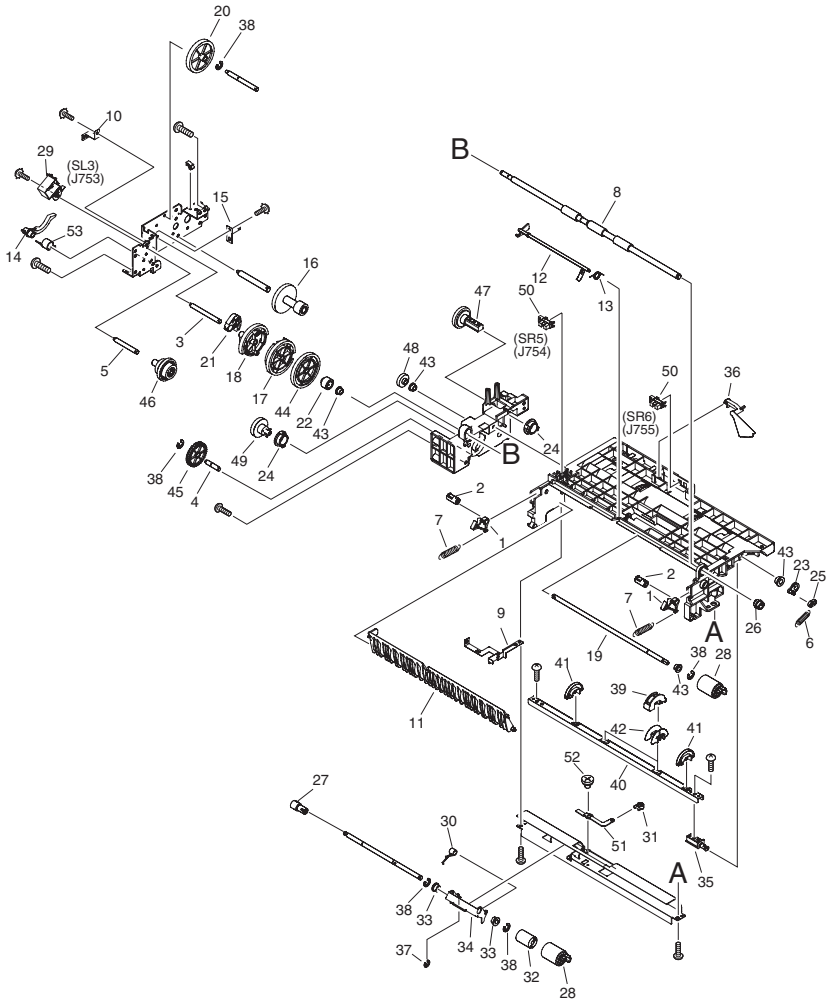
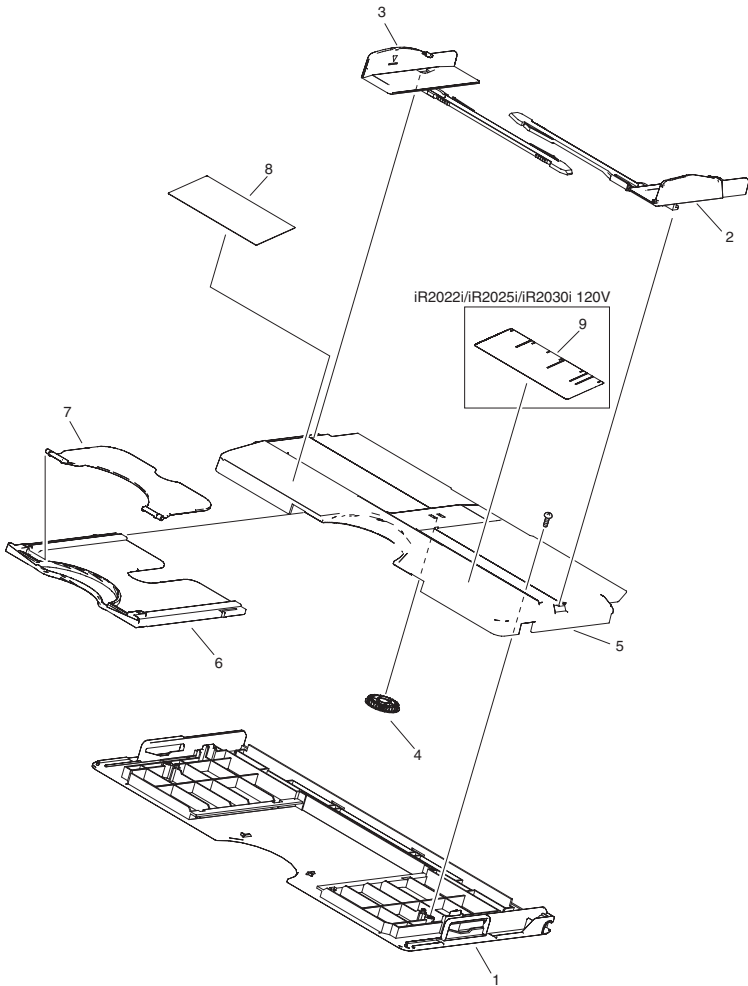

FIGURE & KEY NO.	PARTS NUMBER	R A N K	Q'TY	DESCRIPTION	SERIAL NUMBER/ REMARKS	S V C
Fig.313	FM3-3691-000		1	PAPER PICK-UP ASSEMBLY	EXCEPT iR2018/iR2018i	
1	FA8-2448-000		2	PAWL, LOCK		
2	FA8-2449-000		2	SHAFT, LOCK		
3	FB4-6032-000		1	SHAFT, CLUCH		
4	FB4-6033-000		1	SHAFT, IDLER		
5	FB4-6034-000		1	SHAFT		
6	FB6-1550-000		1	SPRING, TENSION		
7	FB6-1551-000		2	SPRING, TENSION		
8	FB6-1613-000		1	ROLLER, VERTICAL PATH		
9	FB6-1614-000		1	PLATE, GROUNDING		
10	FB6-1615-000		1	PLATE, GROUNDING		
11	FB6-1616-000		1	GUIDE, VERTICAL PATH		
12	FB6-1623-000		1	ARM, FEED SENSOR		
13	FB6-1624-000		1	SPRING, TORSION		
14	FB6-1626-000		1	LEVER, COUPLING		
15	FB6-1628-000		1	PLATE, GROUNDING		
18	FB6-1634-000		1	GEAR, 29T		
19	FB6-1635-000		1	SHAFT		
20	FB6-1636-000		1	GEAR, 39T		
21	FB6-1660-000		1	CAM		
22	FB6-1905-000		1	GEAR, 14T		
23	FB6-1909-000		1	BUSHING		
24	FC6-4304-000		2	BUSHING, ROLLER, PICK-UP		
25	FC6-4352-000		1	COLLAR, SPRING		
26	FC6-4355-000		1	BUSHING		
27	FC6-4358-000		1	JOINT, RETARD		
28	FF6-1621-000		2	ROLLER, SEPARATION		
29	FK2-1104-000		1	SOLENOID	SL3 J753	
30	FU7-2234-000		1	SPRING, TORSION		
31	FB6-1908-000		1	CAP		
32	FC6-4290-000		1	LIMITER, TORQUE		
33	FB6-1541-000		2	BUSHING		

FIGURE & KEY NO.	PARTS NUMBER	RANK	Q'TY	DESCRIPTION	SERIAL NUMBER/REMARKS	SVC
34	FF6-1610-000		1	HOLDER, SEPARATION ROLLER		
35	FC6-4351-000		1	SHAFT, ROLLER		
36	FC6-4350-000		1	ARM, DETECTION, PAPER		
37	XD9-0133-000		1	RING, E		
38	XD9-0136-000		5	RING, E		
39	FB4-9817-030		2	ROLLER, PICK-UP		
40	FB6-1631-030		1	SHAFT, PICK-UP ROLLER		
41	FC6-4356-000		2	ROLLER, LOOP		
42	FE5-4048-000		2	BLOCK, PICK-UP ROLLER ADPTER		
43	FS1-1205-000		4	BUSHING		
44	FS7-0225-000		1	GEAR, 53T		
45	FS7-0226-000		1	GEAR, 36T		
46	FS7-0227-000		1	GEAR, 21T/33T/22T		
47	FS7-0228-000		1	GEAR, 31T		
48	FS7-0229-000		1	GEAR, 18T		
49	FS7-0230-000		1	GEAR, 27T		
50	WG8-5624-000		2	IC, PHOTO INTERRUPTER	SR5,6 J754,755	
51	FC6-4288-000		1	LEVER, PRESSURE		
52	FS5-9714-000		1	SCREW, STEPPED, M3		
53	FU6-2175-000		1	SPRING, TORSION		

FIGURE 315 MULTI FEED TRAY ASS'Y



NOTE1:This assembly is included in the assbly shown in Figure 140.

NOTE2:This assembly does not include the part shown with key No.9.

注 1 :このユニットはFigure140のユニットに含まれます。

注 2 :このユニットにKey No.9の部品は含まれません。

FIGURE & KEY NO.	PARTS NUMBER	RANK	Q'TY	DESCRIPTION	SERIAL NUMBER/REMARKS	SVC
Fig.315	FM2-3294-000		1	MULTI FEED TRAY ASSY	SEE NOTE1	
1	FC6-4215-000		1	COVER, MULTI FEED		
2	FC6-4218-000		1	PLATE, LIMIT, FRONT		
3	FC6-4219-000		1	PLATE, LIMIT, REAR		
4	FC6-4220-000		1	GEAR, PINION		
5	FC6-4221-000		1	TRAY, MULTI FEED		
6	FC6-4222-000		1	TRAY, MULTI FEED, SUB (L)		
7	FC6-4223-000		1	TRAY, MULTI FEED, SUB (S)		
8	FU5-8605-000		1	LABEL, SET		
9	FU5-8589-000		1	LABEL, SIZE INSTRUCTION	iR2022i/iR2025i/iR2030i 120V	

FIGURE 350 PAPER DELIVERY ASSEMBLY

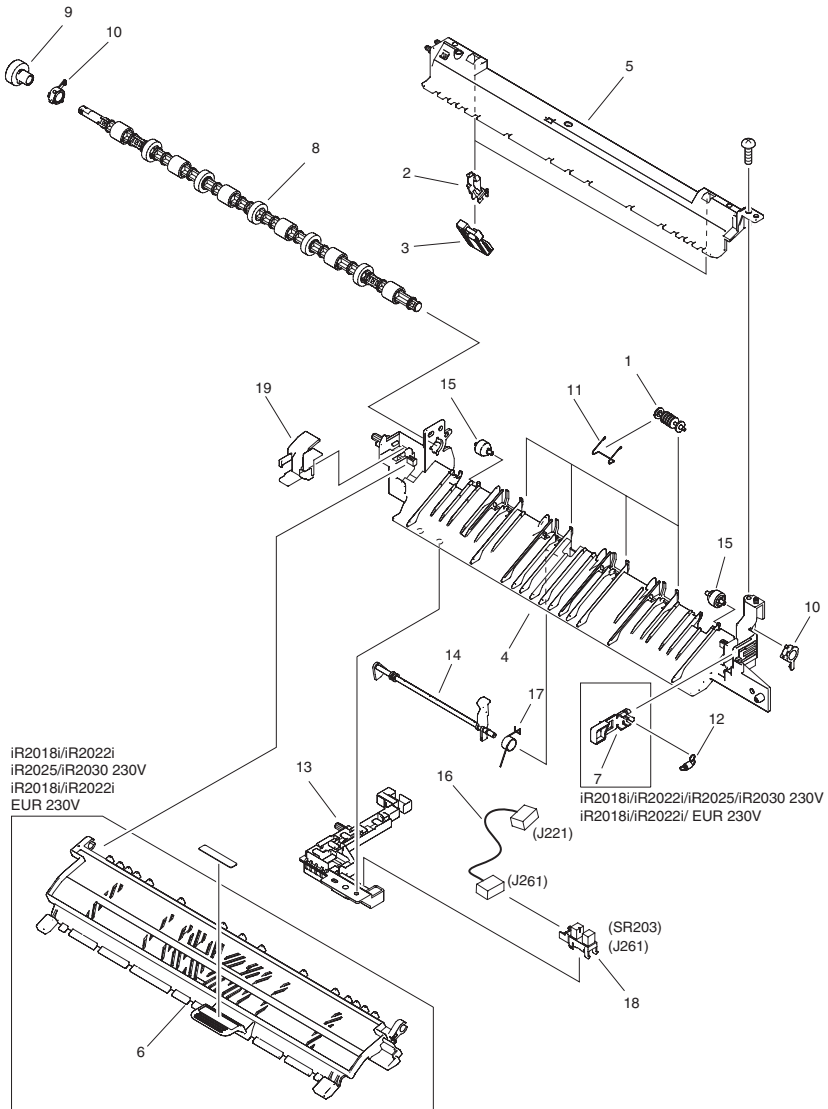

NOTE: This assembly does not include the part shown with key No. 19.
 注：このユニットにKey No.19の部品は含まれません。

FIGURE & KEY NO.	PARTS NUMBER	RANK	Q'TY	DESCRIPTION	SERIAL NUMBER/REMARKS	SVC
Fig.350	FM3-3660-000		1	PAPER DELIVERY ASSEMBLY	iR2018i/iR2022i/iR2025/ iR2030 230ViR2018i/ iR2022i EUR 230V	
Fig.350	FM3-3711-000		1	PAPER DELIVERY ASSEMBLY	iR2018i/2022i/2025i/2030i 120ViR2018i/2022i/2025/ 2025i/2030/2030i AU 230ViR2025/2030/2025i/ 2030i EUR 230V	
1	FC8-0209-000		4	ROLLER, FEEDING		
2	FC6-4438-020		2	HOLDER, RETAINING PLATE		
3	FC6-4477-000		2	PLATE,DELIVERY RETAINING		
4	FC6-4470-000		1	GUIDE, DELIVERY, LOWER		
5	FC6-4474-000		1	GUIDE, DELIVERY, UPPER		
6	FC8-0215-000		1	GUIDE, DELIVERY	iR2018i/iR2022i/iR2025/ iR2030 230ViR2018i/ iR2022i EUR 230V	
7	FC6-4502-000		1	STOPPER, DELIVERY GUIDE	iR2018i/iR2022i/iR2025/ iR2030 230ViR2018i/ iR2022i EUR 230V	
8	FL2-3220-000		1	ROLLER, DELIVERY		
9	FU5-0732-000		1	GEAR, 17T		
10	FU5-1522-000		2	BUSHING, DELIVERY ROLLER		
11	FU6-2189-000		4	SPRING, TORSION		
12	FU6-2206-000		1	SPRING, TENSION		
13	FC6-4465-000		1	HOLDER, SENSOR	SR203	
14	FC6-4473-000		1	LEVER, DELIVERY SENSOR		
15	FC6-4484-000		2	ROLLER		
16	FM2-4789-000		1	CABLE, SENSOR, DELIVERY		
17	FU6-2210-000		1	SPRING, TORSION		
18	WG8-5696-000		1	PHOTO INTERRUPTER, TLP1243	SR203 J261	
19	FC6-4504-000		1	COVER, GEAR		

FIGURE & KEY NO.	PARTS NUMBER	RANK	Q'TY	DESCRIPTION	SERIAL NUMBER/REMARKS	SVC
Fig.640	FM3-3671-000		1	DEVELOPING ASSEMBLY		
1	FU6-0765-000		1	GEAR, 32T		
2	FC6-4164-000		1	BUSHING, SLEEVE, FRONT		
3	FC6-4165-000		1	BUSHING, SLEEVE, REAR		
4	FC6-4166-000		1	ROD, STEERING		
5	FC6-4167-000		1	ROD, DETECTION		
6	FC6-4168-000		1	GUIDE, POSITIONING, MAGNET		
7	FC6-4169-000		1	COUPLER		
8	FC6-4170-000		1	PLATE, TERMINAL, SLEEVE		
10	FL2-3304-000		1	ROD, STEERING		
11	FC6-4176-000		1	PAD, SIDE, FRONT		
12	FC6-4177-000		1	PAD, SIDE, REAR		
13	FL2-3193-000		1	GEAR ASSEMBLY		
14	FL2-3194-000		1	GEAR ASSEMBLY		
15	FL2-3197-000		1	SHUTTER ASSEMBLY		
16	FC6-4163-000		1	PLATE, DETECTION		
17	FC6-4202-000		1	PLATE, TERMINAL		
18	FM2-3287-000		1	LID, DEVELOPING		
19	FM2-3288-000		1	DEVELOPING SLEEVE UNIT		
20	FM3-3672-000		1	DEVELOPING BLADE UNIT		
21	FU6-0762-000		1	GEAR, 31T		
22	FU6-0763-000		1	GEAR, 70T		
23	FU6-0764-000		1	GEAR, 31T/19T		
24	FB6-6896-000		1	CAP. DEVELOPPING		

FIGURE 810 FIXING ASSEMBLY

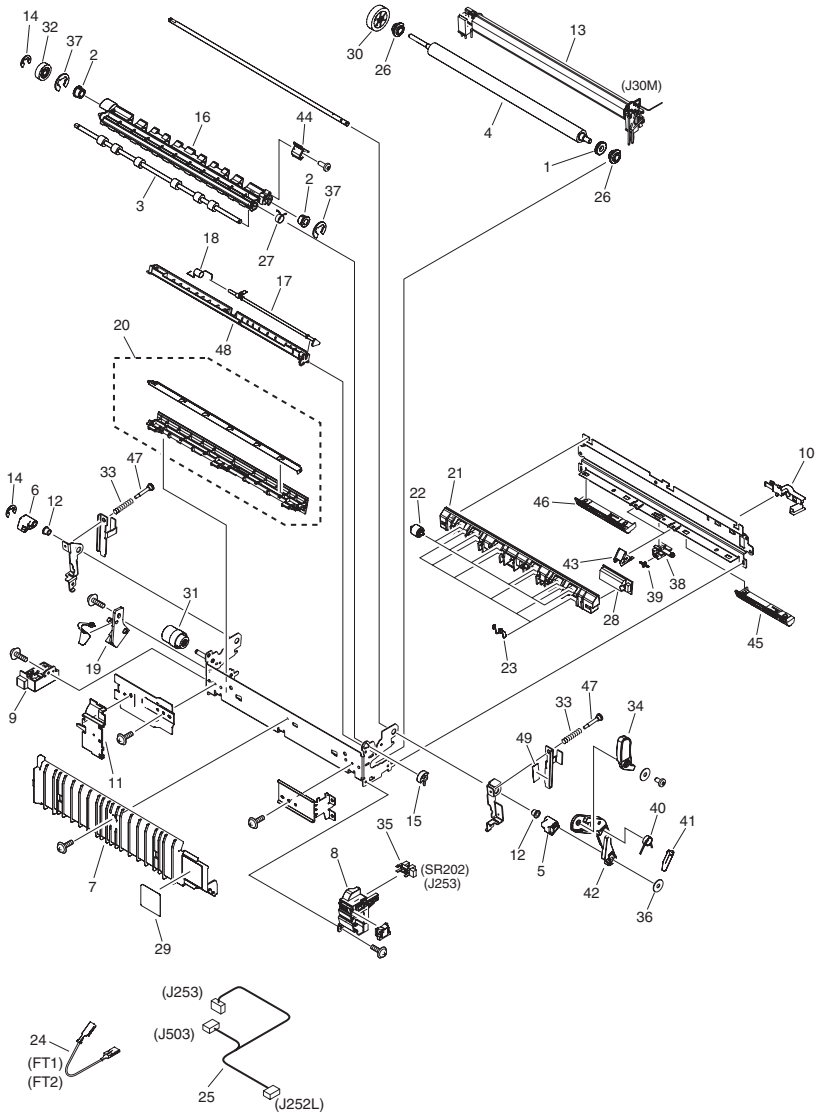

NOTE : This assembly does not include the parts shown with key No. 36,40,41 and 42.
 注 : このユニットにKey No36, 40, 41, 42の部品は含まれません。

FIGURE & KEY NO.	PARTS NUMBER	R A N K	Q'TY	DESCRIPTION	SERIAL NUMBER/ REMARKS	S V C
Fig.810	FM3-3651-000		1	FIXING ASSEMBLY	120V	
Fig.810	FM3-3650-000		1	FIXING ASSEMBLY	230V	
1	FC5-6806-000		1	RUBBER RING, CONDUCTIVE		
2	FU5-1946-000		2	BUSHING		
3	FC8-0197-000		1	ROLLER, DELIVERY, MIDDLE		
4	FC5-5264-000		1	ROLLER, PRESSURE		
5	FC8-0184-000		1	BLOCK, PRESSURE RELEASE (F)		
6	FC8-0185-000		1	BLOCK, PRESSURE RELEASE (R)		
7	FC8-0198-000		1	COVER, FIXING, LEFT		
8	FC8-0199-000		1	GUIDE, FIXING CABLE (F)		
9	FC6-4481-000		1	GUIDE, FIXING CABLE (R)		
10	FC8-0200-000		1	GUIDE, FILM SENSOR CABLE		
11	FC8-0204-000		1	COVER, FIXING GEAR		
12	FU5-1944-000		2	BUSHING		
13	FM3-3654-000		1	FIXING FILM ASSEMBLY	120V	
13	FM3-3653-000		1	FIXING FILM ASSEMBLY	230V	
14	XD9-0134-000		2	RING, E		
15	FU5-1945-000		1	BUSHING		
16	FC8-0189-000		1	GUIDE, DELIVERY, LOWER		
17	FC8-0196-000		1	LEVER, DELIVERY SENSOR		
18	FU7-2228-000		1	SPRING, TORSION		
19	FC8-0190-000		1	TERMINAL HOLDER ASSEMBLY		
20	FM3-3710-000		1	FIXING INLET GUIDE UNIT		
21	FC8-0191-000		1	GUIDE, DELIVERY, UPPER		
22	FC5-6805-000		6	ROLLER, DELIVERY, MIDDLE		
23	FU6-2188-000		6	SPRING, TORSION		
24	FM2-4405-000		1	CABLE, FILM BIAS	FT1,2	
25	FM3-3526-000		1	CABLE, FIXING SENSOR		
26	FC5-5265-000		2	BUSHING		
27	FU7-2229-000		1	SPRING, TORSION		
28	FM3-3024-000		1	PCB, FIXING FILM SENSOR		
29	FU5-8576-000		1	LABEL, DRUM CAUTION		

FIGURE & KEY NO.	PARTS NUMBER	R A N K	Q'TY	DESCRIPTION	SERIAL NUMBER/ REMARKS	S V C
30	FU7-0930-000		1	GEAR, 27T	SR202 J253	
31	FU7-0931-000		1	GEAR, 17T		
32	FU7-0932-000		1	GEAR, 17T		
33	FU7-2227-000		2	SPRING, TENSION		
34	FC8-0208-000		1	LEVER, RELEASE		
35	WG8-5696-000		1	PHOTO INTERRUPTER, TLP1243		
36	XD9-0212-000		1	WASHER, M3 FOR PLAIN		
37	XD9-0136-000		2	RING, E		
38	FC6-4458-020		1	MOUNT, ROWEL		
39	FC6-4375-000		9	ROWEL		
40	FU6-2208-000		1	SPRING, TORSION		
41	FC6-4454-000		1	BLOCK, LEVER RETURN		
42	FC8-0183-000		1	LEVER, RELEASE, FRONT		
43	FC6-4467-000		2	GUIDDE, PAPER LIMIT		
44	FC8-0203-000		1	LEVER, DELIVERY GUIDE, LW.		
45	FC8-0192-000		1	GUIDE, FIXING UP. INLET, FRONT		
46	FC8-0193-000		1	GUIDE, FIXING UP. INLET, REAR		
47	FC8-0194-000		2	SCREW, PRESSURE, ADJUSTING		
48	FC8-0195-000		1	GUIDE, DELIVERY FIXED, LOWER		
49	FC8-0207-000		1	SHEET, PRESSURE PLATE PROTECT.		

FIGURE 900 IMAGE PROCESSOR PCB ASS'Y

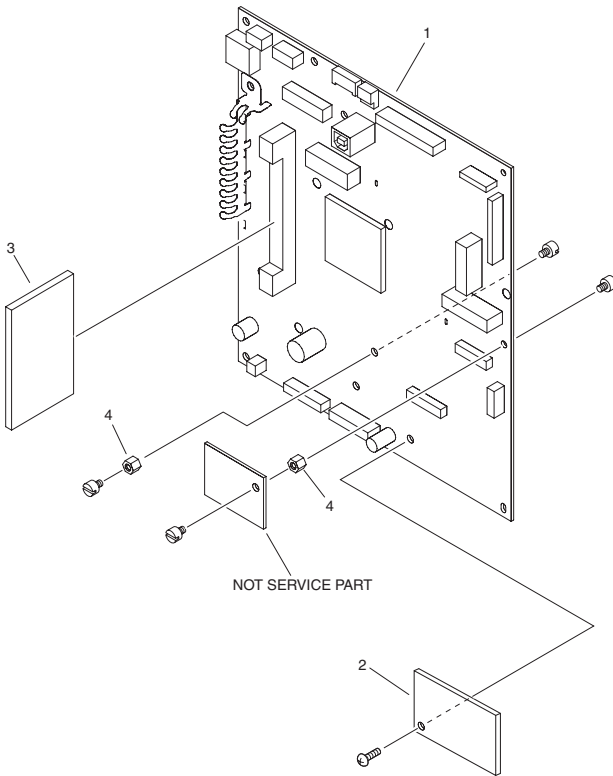

FIGURE & KEY NO.	PARTS NUMBER	RANK	Q'TY	DESCRIPTION	SERIAL NUMBER/REMARKS	SVC
Fig.900	NPN		RF	IMAGE PROCESSOR PCB ASS'Y		
1	FM3-3319-000		1	IMAGE PROCESSOR PCB ASS'Y		
2	FM3-3327-000		1	ROM PCB ASSEMBLY		
3	FM3-3324-000		1	DDR MODULE PCB ASS'Y		
4	VT2-5177-005		2	SPACER, METAL		
IC	FK2-0949-000		1	IC, UPD65942GC-Y24, GATE ARRAY	IC140	

FIGURE C10 COPYBOARD COVER ASSEMBLY

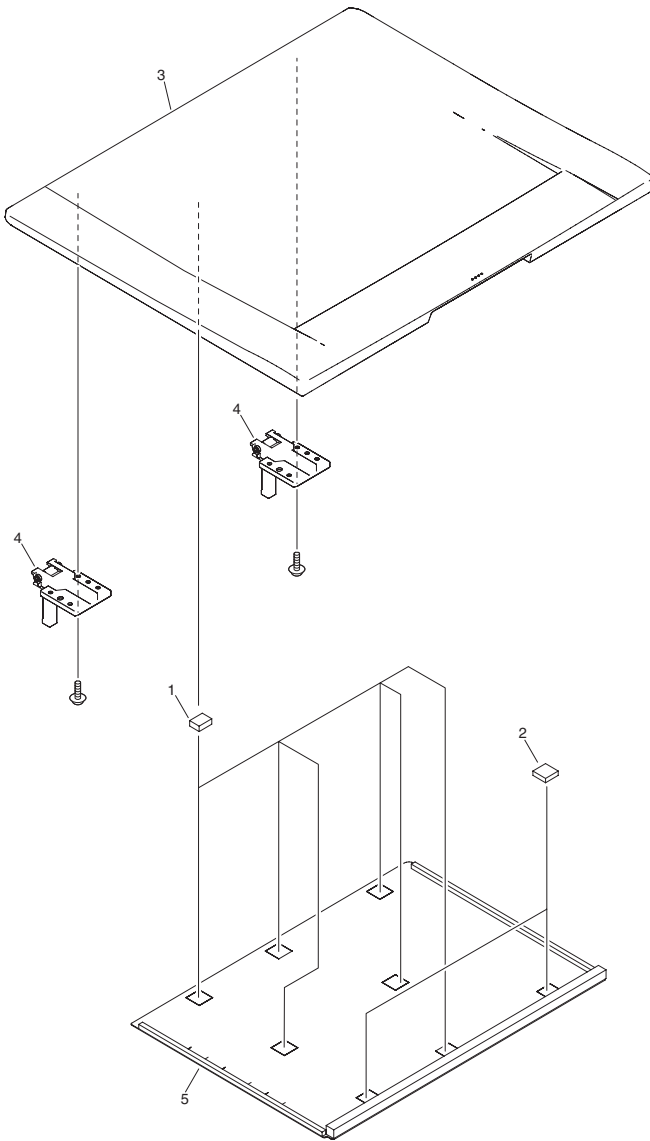

FIGURE & KEY NO.	PARTS NUMBER	RANK	Q'TY	DESCRIPTION	SERIAL NUMBER/REMARKS	SVC
Fig.C10	NPN		RF	COPYBOARD COVER ASSEMBLY	iR2025/iR2030 230V	
1	FC6-4508-000		6	SPONGE, 1		
2	FC6-4509-000		2	SPONGE, 2		
3	FC6-4576-000		1	COVER, COPYBOARD		
4	FC6-4738-000		2	HINGE		
5	FL2-3186-000		1	COVER, COPYBOARDWHITE-BOARD		

FIGURE P01 PACKING KIT

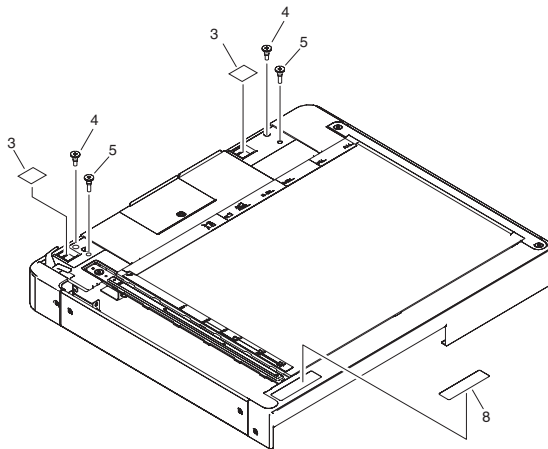
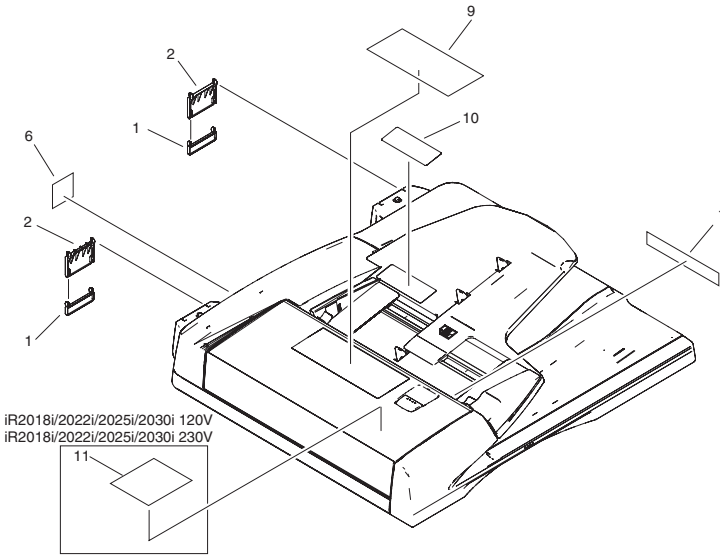

FIGURE & KEY NO.	PARTS NUMBER	R A N K	Q'TY	DESCRIPTION	SERIAL NUMBER/ REMARKS	S V C
Fig.P01	NPN		RF	PACKING KIT	iR2018i/iR2022i/iR2025i/ iR2030i	
1	FC3-1571-000		2	COVER, HINGE		
2	FC3-1572-000		2	COVER, HINGE		
3	FC3-1547-000		2	SHEET, BLANKING		
4	FU5-9140-000		2	SCREW, STEPPED, M4X10		
5	FU5-9139-000		2	SCREW, STEPPED, M5X6		
6	FS9-0196-000		1	LABEL, CAUTION		
7	FS9-0211-000		1	LABEL, DOCUMENT SIZE		
8	FS9-0214-000		1	LABEL, CLEANING		
9	FS9-0201-000		1	LABEL, DOCUMENT PROHIBITION		
9	FS9-0202-000		1	LABEL, DOCUMENT PROHIBITION		
10	FS9-0208-000		1	LABEL, DOCUMENT SIZE	iR2018i/iR2022i/iR2025i/ iR2030i EUR 230V	
10	FS9-0209-000		1	LABEL, DOCUMENT SIZE	iR2018i/iR2022i 230ViR2018i/iR2022i/ iR2025i/iR2030i AU 230V	
11	FC8-0634-000		1	LABEL, CLEANING	iR2018i/iR2022i/iR2025i/ iR2030i 120ViR2018i/ iR2022i/iR2025i/iR2030i 230V	

FIGURE P11 ADF ASSEMBLY

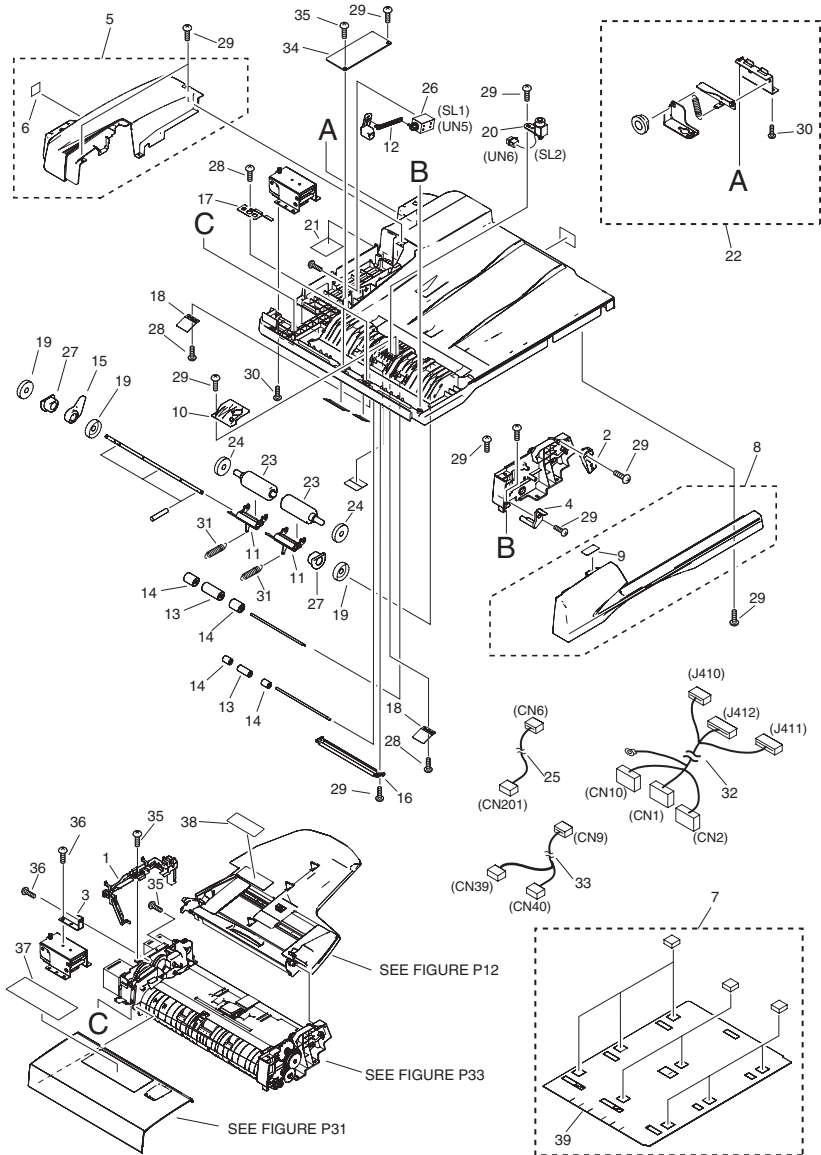

FIGURE & KEY NO.	PARTS NUMBER	R A N K	Q'TY	DESCRIPTION	SERIAL NUMBER/ REMARKS	S V C
Fig.P11	NPN		RF	ADF ASSEMBLY	iR2018/iR2022i/iR2025/ iR2030i	
1	FC3-1468-000		1	HOLDER, HARNESS		
2	FC3-1492-000		1	HOLDER, TRAY SHAFT		
3	FC3-1496-000		1	BRACKET, SUPPORT		
4	FC3-1539-000		1	HOLDER, FEEDER SHAFT		
5	FF3-4621-000		1	PANEL, REAR		
6	FS9-0198-000		1	LABEL, HINGE CAUTION		
7	FF3-4624-000		1	PANEL, COPYBOARD		
8	FF3-4634-000		1	PANEL, FRONT		
9	FS9-0203-000		1	LABEL, DIAL OPERATION		
10	FC3-1449-000		1	COVER, STAMP		
11	FC3-1450-000		2	HOLDER, DELIVERY RELEASE		
12	FC3-1452-000		1	ARM, SOLENOID		
13	FC3-1454-000		2	ROLLER, PAPER FEED, 1		
14	FC3-1455-000		4	ROLLER, PAPER, FEED, 2		
15	FC3-1491-000		1	ARM, DELIVERY RELEASE		
16	FC3-1495-000		1	COVER, FEED		
17	FC3-1497-000		2	SPRING, LEAF		
18	FC3-1498-000		2	SPRING, LEAF		
19	FC3-1549-000		3	CLIP		
20	FK2-0216-000		1	SOLENOID	SL2 CN6	
21	FS9-0197-000		1	LABEL, HINGE CAUTION		
22	FG3-4039-000		1	HINGE UNIT(RIGHT)		
23	FC3-1451-000		2	ROLLER		
24	FC3-1513-000		2	ROLLER, PRESS		
25	FH2-7211-000		1	CABLE, STAMP		
26	FH6-5136-000		1	SOLENOID	SL1 CN5	
27	FS2-1707-000		2	BUSHING, DELIVERY RELEASE		
28	FS2-9568-000		4	SCREW, M3X8		
29	FS2-9569-000		12	SCREW, M3X10		
30	FS2-9571-000		7	SCREW, M4X12		

FIGURE & KEY NO.	PARTS NUMBER	R A N K	Q'TY	DESCRIPTION	SERIAL NUMBER/REMARKS	S V C
31	FS4-2743-000		2	SPRING		
32	FH2-7206-000		1	CABLE, INTERFACE		
33	FH2-7210-000		1	CABLE, OPEN/CLOSE SENSOR		
34	FK2-5787-000		1	CONNECTION PCB UNIT		
35	FS2-9567-000		3	SCREW, M3X6		
36	FS2-9570-000		2	SCREW, M4X7		
37	FS9-0201-000		1	LABEL, DOCUMENT PROHIBITION	iR2018i/iR2022i/iR2025i/ iR2030i 120ViR2018i/ iR2022i 230ViR2018i/ iR2022i/iR2025i/iR2030i AU 230V	
37	FS9-0202-000		1	LABEL, DOCUMENT PROHIBITION	iR2018i/iR2022i/iR2025i/ iR2030i EUR 230V	
38	FS9-0207-000		1	LABEL, DOCUMENT SIZE	iR2018i/iR2022i/iR2025i/ iR2030i 120V	
38	FS9-0211-000		1	LABEL, DOCUMENT SIZE	iR2018i/iR2022i/iR2025i/ iR2030i 120ViR2018i/ iR2022i/iR2025i/iR2030i 230V	
39	FC3-1569-000		1	COVER, COPYBOARD		

FIGURE P12 DOCUMENT TRAY ASSEMBLY

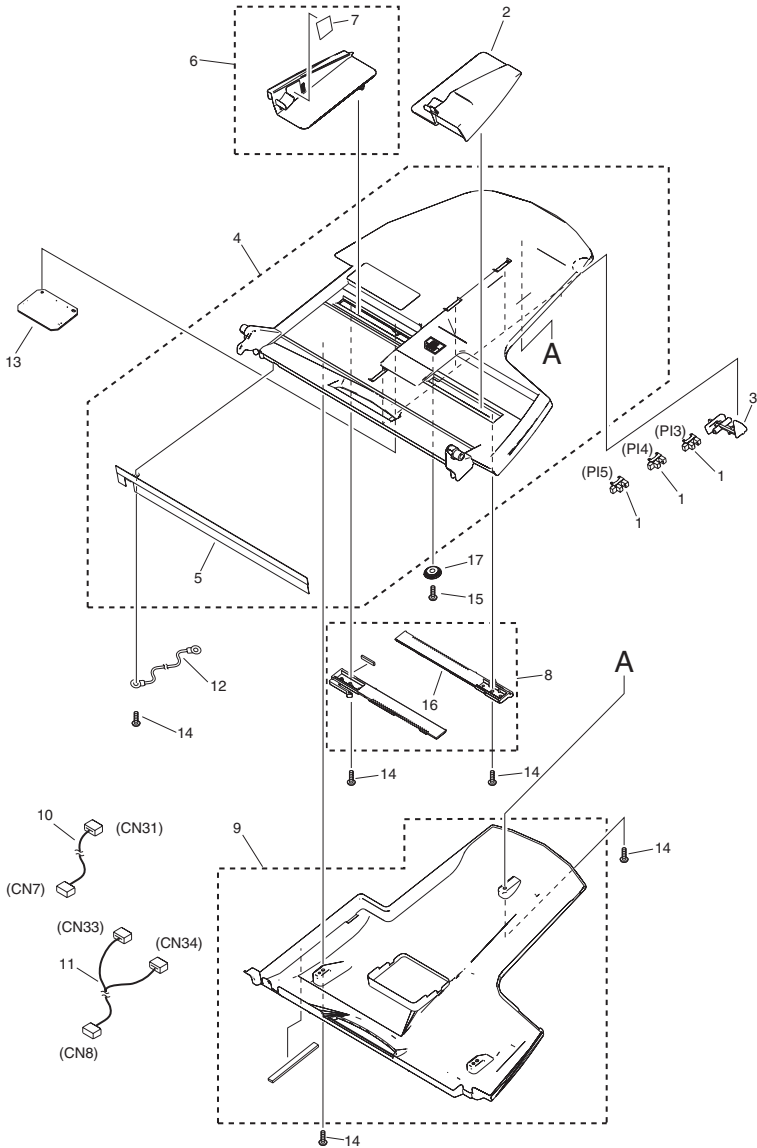

FIGURE & KEY NO.	PARTS NUMBER	R A N K	Q'TY	DESCRIPTION	SERIAL NUMBER/REMARKS	S V C
Fig.P12	FG3-4036-000		1	DOCUMENT TRAY ASSEMBLY	iR2018i/iR2022i/iR2025i/iR2030i	
1	WG8-5696-000		3	PHOTO INTERRUPTER, TLP1243		
2	FC3-1486-000		1	GUIDE, TRAY, FRONT		
3	FC3-1488-000		3	LEVER, TRAY SENSOR		
4	FF3-4625-000		1	TRAY, DOCUMENT, UPPER		
5	FC3-1529-000		1	ELIMINATOR, STATIC CHARGE		
6	FF3-4626-000		1	GUIDE, TRAY		
7	FS9-0210-000		1	LABEL, DOCUMENT HEIGHT LIMIT		
8	FF3-4627-000		1	RACK, TRAY		
9	FF3-4628-000		1	COVER, TRAY, LOWER		
10	FH2-7207-000		1	CABLE, DOCUMENT TRAY	CN7,31	
11	FH2-7208-000		1	CABLE, SIZE DETECTION SENSOR	CN8,33,34	
12	FH2-7212-000		1	CABLE, STATIC ELIMINATOR		
13	FH5-3731-000		1	CONNECTING PCB UNIT		
14	FS2-9569-000		6	SCREW, M3X10		
15	FS2-9572-000		1	SCREW, M3X10		
16	FS4-0657-000		1	RACK, TRAY		
17	FS4-0658-000		1	GEAR, 16T		

FIGURE P31 OPEN/CLOSE PANEL ASSEMBLY

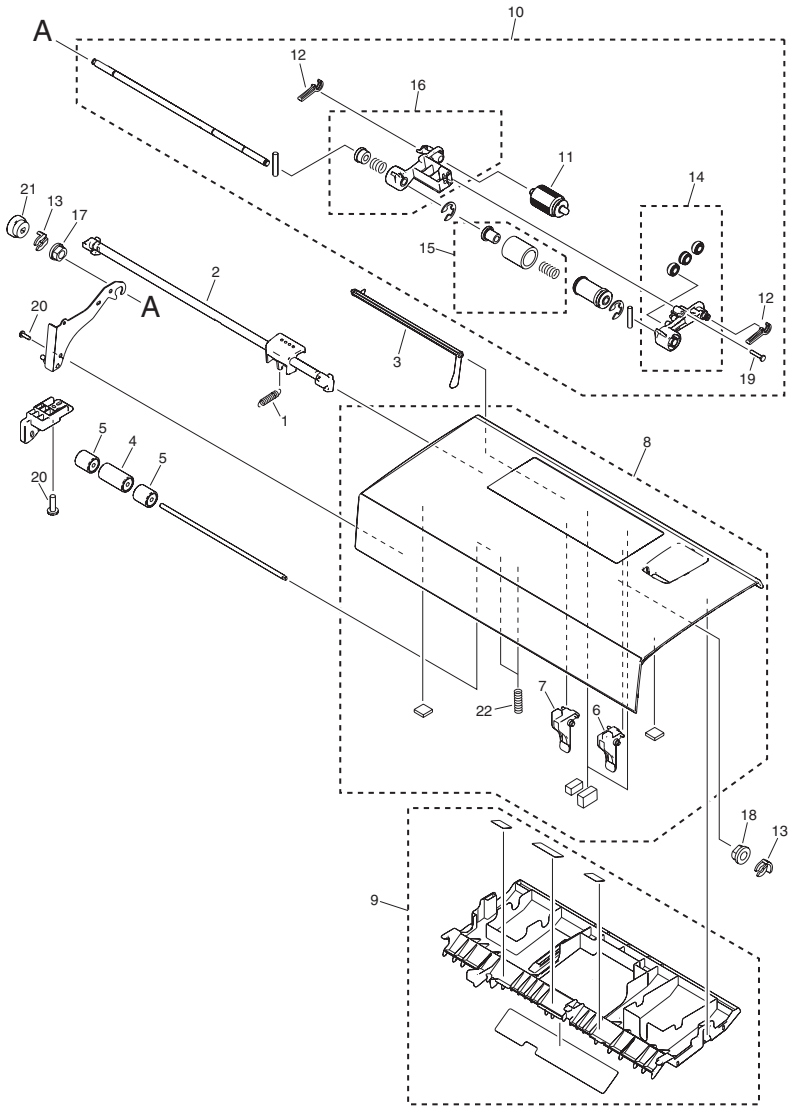

FIGURE & KEY NO.	PARTS NUMBER	R A N K	Q'TY	DESCRIPTION	SERIAL NUMBER/ REMARKS	S V C
Fig.P31	FG3-4037-000		1	OPEN/CLOSE PANEL ASSEMBLY	iR2018/iR2022i/iR2025i/ iR2030i 120ViR2018i/ iR2022iiR2025i/iR2030i EUR 230V	
Fig.P31	FG3-4052-000		1	OPEN/CLOSE PANEL ASSEMBLY	iR2018/iR2022i 230ViR2018i/iR2022i/ iR2025i/iR2030i AU 230V	
1	FS4-2754-000		1	SPRING, TENSION		
2	FC3-1477-000		1	LEVER, OPEN/CLOSE		
3	FC3-1478-000		1	LEVER, SENSOR		
4	FC3-1479-000		1	ROLLER, REGISTRATION, 1		
5	FC3-1480-000		2	ROLLER, REGISTRATION, 2		
6	FC3-1540-000		1	SHUTTER, FRONT		
7	FC3-1541-000		1	SHUTTER, REAR		
8	FF3-4629-000		1	PANEL, OPEN/CLOSE	A SIZE A/INCH SIZE	
8	FF3-4637-000		1	PANEL, OPEN/CLOSE	iR2018/iR2022i 230ViR2018i/iR2022i/ iR2025i/iR2030i AU 230V	
9	FF3-4630-000		1	GUIDE, OPEN/CLOSE		
10	FG3-4043-000		1	PICK-UP ROLLER ASSEMBLY		
11	FC3-1525-000		1	ROLLER, PICK-UP		
12	FC3-1542-000		2	STOPPER		
13	FC3-1549-000		2	CLIP		
14	FG3-4041-000		1	PICK-UP ARM UNIT, FRONT		
15	FG3-4044-000		1	SEPARATION ROLLER UNIT		
16	FG3-4045-000		1	PICK-UP ARM UNIT,REAR		
17	FS2-1708-000		1	BUSHING		
18	FS2-1710-000		1	BUSHING		
19	FS2-9573-000		1	SCREW, M3X16		
20	FS2-9569-000		4	SCREW, M3X10		
21	FS4-0654-000		1	GEAR, 25T		
22	FS4-2747-000		2	SPRING, COMPRESSION		

FIGURE P33 PAPER FEEDER ASSEMBLY

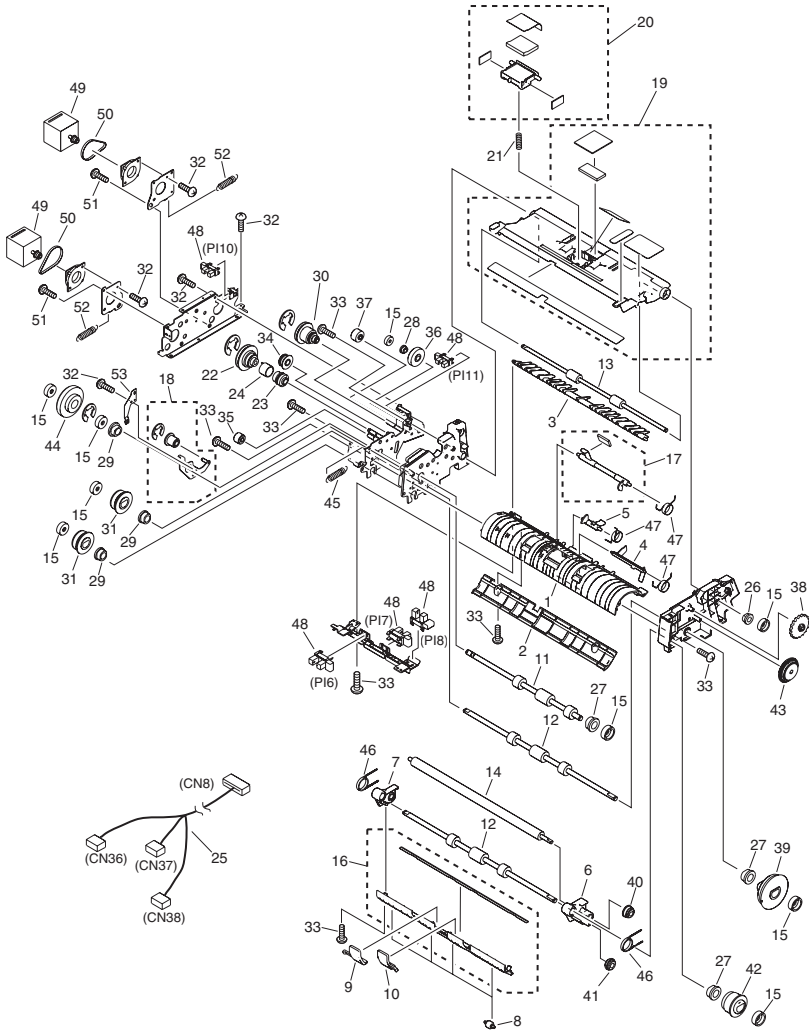

FIGURE & KEY NO.	PARTS NUMBER	R A N K	Q'TY	DESCRIPTION	SERIAL NUMBER/ REMARKS	S V C
Fig.P33	FG3-4038-020		1	PAPER FEEDER ASSEMBLY	iR2018/iR2022i/iR2025/ iR2030i	
1	FC3-1460-000		1	GUIDE, FEEDER		
2	FC3-1462-000		1	GUIDE, PLATEN		
3	FF3-4638-000		1	FLAPPER		
4	FC3-1465-000		1	FLAG, READ SENSOR		
5	FC3-1466-000		1	FLAG, DELIVERY REVERSE SENSOR		
6	FC3-1469-000		1	ARM, PLATEN, FRONT		
7	FC3-1470-000		1	ARM, PLATEN, REAR		
8	FC3-1471-000		4	ROLLER, PLATEN		
9	FC3-1493-000		1	SPACER, PLATEN, FRONT		
10	FC3-1494-000		1	SPACER, PLATEN, REAR		
11	FC3-1509-000		1	ROLLER, REGISTRATION, 1		
12	FC3-1510-000		2	ROLLER, READ		
13	FC3-1511-000		1	ROLLER, DELIVERY REVERSE		
14	FC3-1512-000		1	ROLLER, WHITE		
15	FC3-1549-000		9	CLIP		
16	FF3-4633-000		1	PLATEN GUIDE UNIT		
17	FF3-4636-000		1	REGISTRATION SENSOR UNIT		
18	FG3-4040-000		1	TENSION ROLLER UNIT		
19	FF3-4631-000		1	REVERSE GUIDE UNIT		
20	FF3-4632-000		1	SEPARATION PAD UNIT		
21	FS4-2746-000		1	SPRING, COMPRESSION		
22	FS2-3885-000		1	PULLEY, 57T,GEAR, 23T		
23	FS4-0645-000		1	GEAR, 16T		
24	FS4-2752-000		1	SPRING, TENSION		
25	FH2-7209-000		1	CABLE, FEEDER SENSOR	CN8,36,37,38	
26	FS2-1708-000		1	BUSHING		
27	FS2-1709-000		3	BUSHING		
28	FS2-1710-000		1	BUSHING		
29	FS2-1711-000		3	BUSHING		
30	FS2-3886-000		1	PULLEY, 57T/19T, GEAR, 23T		

FIGURE & KEY NO.	PARTS NUMBER	R A N K	Q'TY	DESCRIPTION	SERIAL NUMBER/REMARKS	S V C
31	FS2-3887-000		2	PULLEY, 27T		
32	FS2-9567-000		9	SCREW,M3X6		
33	FS2-9569-000		12	SCREW, M3X10		
34	FS4-0644-000		1	GEAR, 16T		
35	FS4-0646-000		1	GEAR, 19T		
36	FS4-0647-000		1	GEAR, 25T		
37	FS4-0648-000		1	GEAR, 23T		
38	FS4-0649-000		1	DIAL		
39	FS4-0650-000		1	GEAR, 31T		
40	FS4-0651-000		1	GEAR, 14T		
41	FS4-0652-000		1	GEAR, 15T		
42	FS4-0653-000		1	GEAR, 18T		
43	FS4-0659-000		1	GEAR, 54T/39T		
44	FS4-0660-000		1	GEAR, 33T		
45	FS4-2744-000		1	SPRING, TENSION		
46	FS4-2745-000		2	SPRING, TORSION		
47	FS4-2753-000		3	SPRING, TORSION		
48	WG8-5696-000		5	PHOTO INTERRUPTER, TLP1243	P16,7,8,10,11	
49	FH5-1142-000		2	MOTOR, STEPPING		
50	XF2-1607-240		2	BELT, TIMING		
51	FS2-9570-000		4	SCREW, M4X7		
52	FS4-2749-000		2	SPRING, TENSION		
53	FC3-1568-000		1	PLATE, GROUNDING		

FIGURE S01 PACKING KIT

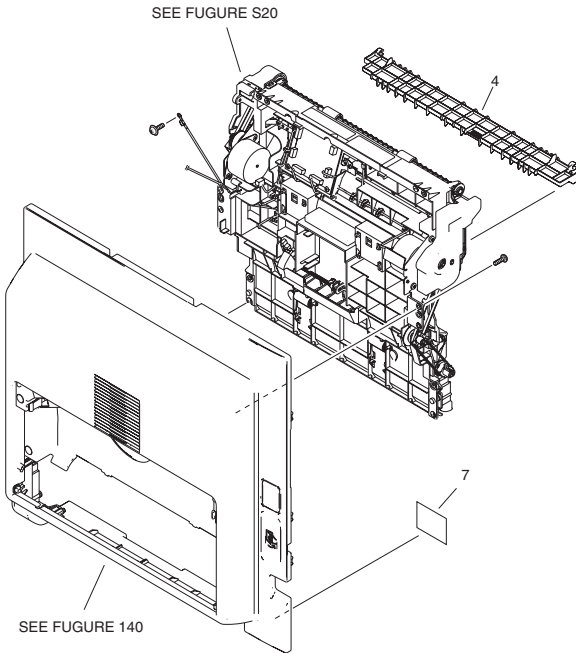
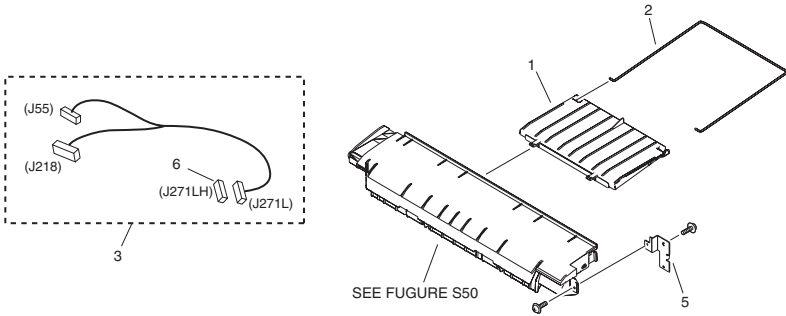

FIGURE & KEY NO.	PARTS NUMBER	RANK	Q'TY	DESCRIPTION	SERIAL NUMBER/REMARKS	SVC
Fig.S01	NPN		RF	PACKING KIT	iR2018i/iR2022i/iR2025i/iR2030i 120ViR2018i/iR2022i/iR2025i/iR2025i/iR2030i/iR2030i AU 230ViR2025i/iR2025i/iR2030i/iR2030i EUR 230V	
1	FC6-6782-000		1	TRAY, REVERSE		
2	FC6-6783-000		1	TRAY, SUB		
3	FM3-3015-000		1	CABLE, DUPLEX UNIT		
4	FL2-8094-000		1	GUIDE, DELIVERY		
5	FC6-6778-000		1	MOUNT, REVERSE GUIDE		
6	VS1-7207-012		1	CONNECTOR		
7	FU5-8699-000		1	LABEL, JAM CLEAR		

FIGURE S20 DUPLEX FEEDER ASSEMBLY

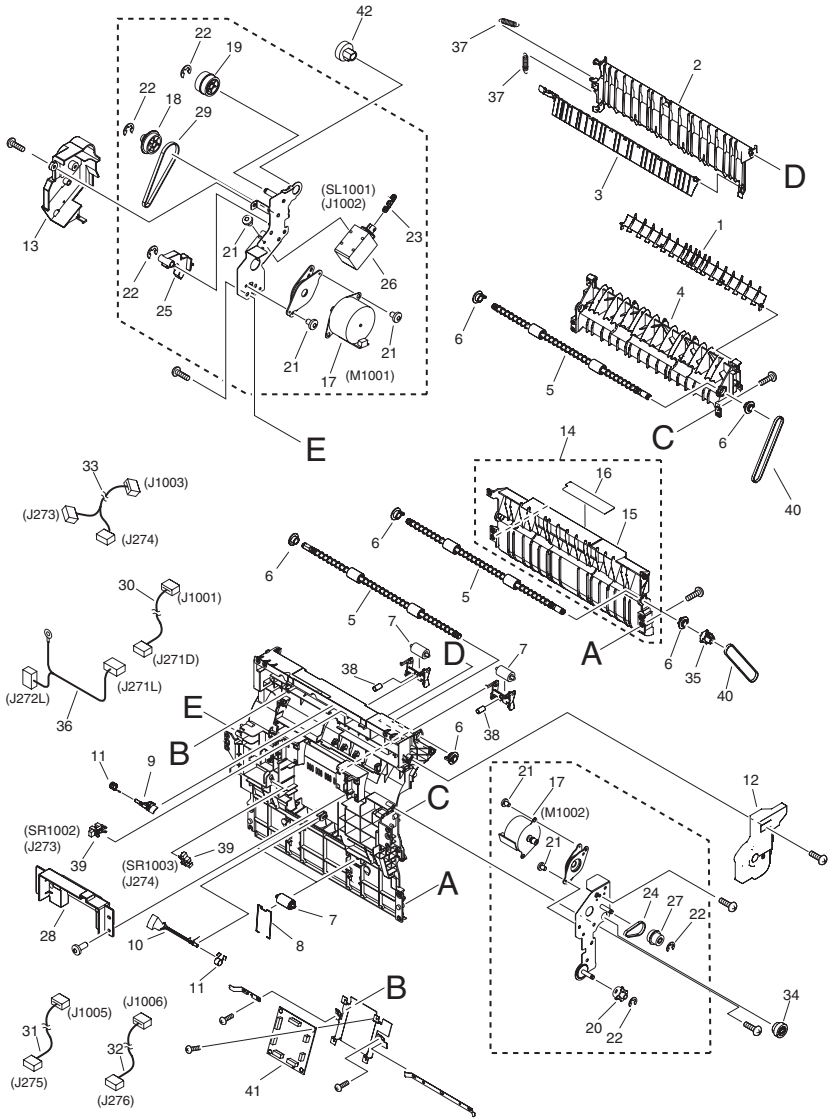

FIGURE & KEY NO.	PARTS NUMBER	RANK	Q'TY	DESCRIPTION	SERIAL NUMBER/REMARKS	SVC
Fig.S20	NPN		RF	DUPLEX FEEDER ASSEMBLY	iR2018i/iR2022i/iR2025i/iR2030i 120ViR2018i/iR2022i/iR2025i/iR2025i/iR2030i AU 230ViR2025i/iR2025i/iR2030i/iR2030i EUR 230V	
1	FC6-6752-000		1	DEFLECTOR, REVERSE		
2	FC6-6753-000		1	GUIDE, DUPLEX SWING		
3	FC6-6755-000		1	DEFLECTOR, DUPLEX		
4	FC6-6756-000		1	GUIDE, RIGHT UPPER		
5	FC6-6757-000		3	ROLLER		
6	FC6-6758-000		6	BUSHING		
7	FC6-6759-000		4	ROLLER		
8	FC6-6760-000		2	SPRING, ROLLER		
9	FC6-6765-000		1	FLAG, REVERSE SENSOR		
10	FC8-0312-000		1	FLAG, FEEDER SENSOR		
11	FC6-6768-000		2	SPRING, TORSION		
12	FC8-0318-000		1	COVER, DUPLEX, FRONT		
13	FC8-0317-000		1	COVER, DUPLEX, REAR		
14	FL2-3856-000		1	GUIDE, RIGHT, LOWER		
15	FC6-6754-000		1	GUIDE, RIGHT, LOWER		
16	FU5-8696-000		1	LABEL, OPERATION PROHIBITION		
17	FK2-5359-000		2	MOTOR, STEPPING	M1001,1002	
18	FU7-0943-000		1	PULLEY, 18T/40T		
19	FU7-0944-000		1	GEAR, 29T/23T		
20	FU6-0936-000		1	GEAR, 28T		
21	XA9-1116-030		11	SCREW, 3X5		
22	XD9-0136-000		5	RING, E		
23	FC6-6740-000		1	PLATE, LINK		
24	XF2-1605-040		1	BELT, TIMING		
25	FC6-6769-000		1	PLATE, LINK		
26	FL2-3744-000		1	SOLENOID	SL1001 J1002	
27	FU7-0940-000		1	PULLEY, 20T/32T		
28	FC8-0313-000		1	HOLDER, FAN		

FIGURE & KEY NO.	PARTS NUMBER	RANK	Q'TY	DESCRIPTION	SERIAL NUMBER/REMARKS	SVC
29	XF2-1609-340		1	BELT, TIMING		
30	FM3-3528-000		1	CABLE, DUPLEX RELAY		
31	FM2-4518-000		1	CABLE, DUPLEX MOTOR		
32	FM2-4519-000		1	CABLE, REVERSE MOTOR		
33	FM2-4520-000		1	CABLE, DUPLEX SENSOR		
34	FU7-0941-000		1	PULLEY, 36T/28T		
35	FU6-0937-000		1	GEAR, 28T		
36	FM3-3531-000		1	CABEL, DUPLEX UNIT		
37	FU6-2387-000		2	SPRING, TENSION		
38	FU6-2388-000		2	SPRING, COMPRESSION		
39	WG8-5696-000		2	PHOTO INTERRRUPTER, RLP1243	SR1002,1003 J273,274	
40	XF2-1112-240		2	BELT, TIMING		
41	FM3-3023-000		1	DUPLEX CONTROLLER PCB ASSEMBLY		
42	FU7-0942-000		1	GEAR, 21T		

FIGURE S50 DUPLEX REVERSE UNIT

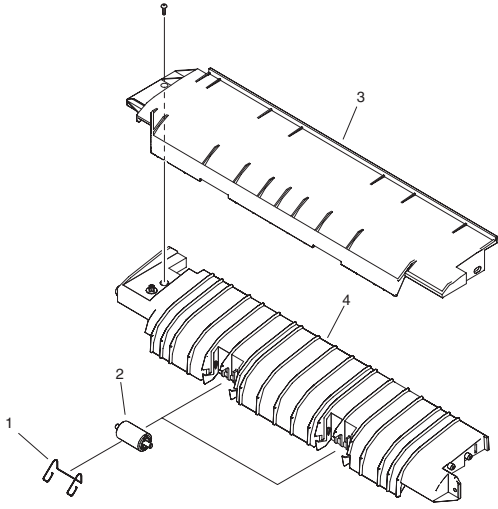

FIGURE & KEY NO.	PARTS NUMBER	RANK	QTY	DESCRIPTION	SERIAL NUMBER/REMARKS	SVC
Fig.S50	FM2-4493-000		1	DUPLEX REVERSE UNIT	iR2018/iR2022i/iR2025i/ iR2030i 120V/iR2018i/ iR2022i/iR2025i/iR2025i/ iR2030i/iR2030i AU 230V/iR2025i/iR2025i/ iR2030i/iR2030i EUR 230V	
1	FC6-6781-000		2	SPRING, ROLLER		
2	FC6-6759-000		2	ROLLER		
3	FC6-6779-000		1	GUIDE, REVERSE UPPER		
4	FC6-6780-000		1	GUIDE, REVERSE, LOWER		

FIGURE X10 FAX ASSEMBLY

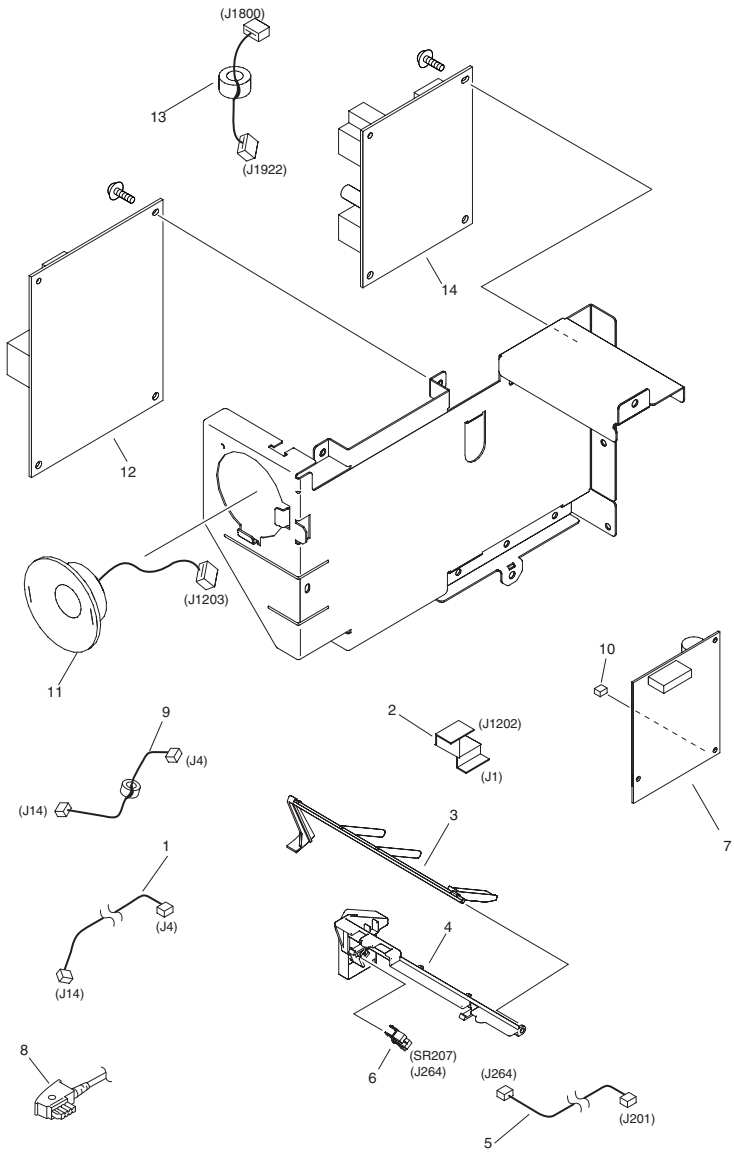

FIGURE & KEY NO.	PARTS NUMBER	RANK	Q'TY	DESCRIPTION	SERIAL NUMBER/REMARKS	SVC
Fig.X10	NPN		RF	FAX ASSEMBLY	IR2018i/2022i/2025i/2030i AU 230V	
1	FM2-4540-000		1	CABLE, NCU	J4,14	
2	FK2-1063-000		1	CABLE, FLAT, MODEM	J1,1202	
3	FC6-4499-000		1	LEVER, SENSOR		
4	FC6-4500-000		1	HOLDER, SENSOR		
5	FM2-4434-000		1	CABLE, SENSOR	J201,264	
6	WG8-5696-000		1	PHOTO INTERRUPTER, TLP1243	SR207 J264	
7	FM3-3334-000		1	MODEM PCB ASSEMBLY		
8	HK1-0559-000		1	MODULAR CORD		
9	FM2-4435-000		1	CABLE, MODEM	J1201,1921	
10	WS1-5792-000		1	PLUG, SHORT		
11	FK2-1265-000		1	SPEAKER	J1203	
12	FM3-3332-000		1	NCU PCB ASSEMBLY		
13	FM2-4540-000		1	CABLE, NCU		
14	FM2-4772-000		1	MODULAR PCB ASSEMBLY		
IC	FK2-0949-000		1	IC,UPD65942GC-Y24, GATE ARRAY	IC1	

FIGURE ZZA

MECHANICAL STANDARD PARTS (HOW TO USE)

Mechanical standard parts

機械標準部品

About a mechanical standard parts

A Mechanical standard parts is a mechanical part which not parts peculiar to a product. They are parts which are common to a Canon product and are used, such as a screw and a washer. The Fig No. and parts number of the mechanical standard parts are not listed in the product parts catalog. Refer to the parts catalog of mechanical standard parts when checking the parts number for screw or washer etc. and identify them by part shape or size.

機械標準部品とは

機械標準部品とは、製品特有の部品ではなく、ねじやワッシャなどキヤノン製品共通で使用されている機械部品（メカ部品）のことです。
製品のパーツカタログには、機械標準部品のFig No.や部品番号は記載しておりません。
ねじや、ワッシャ等の部品番号を調べるときは、機械標準部品のパーツカタログを参照し、部品の形状や大きさから判断し、使用している部品を調べてください。

Material and surface treatment of a mechanical standard parts

Material and surface treatment of mechanical standard parts are assigned commonly for each part. Refer to the Table 1 for the parts which material and surface treatment are assigned as numbers.

機械標準部品の材料および表面処理

機械標準部品の材料および表面処理については、各種部品共通で決められています。
材料および表面処理が番号で決められている部品については、表1を参照してください。

Table 1 Material and Surface treatment

表1 材料および表面処理

No. 番号	Material 材料	Surface treatment 表面処理	Color 色
1	Stainless steel ステンレス	Stainless steel black coloring (BC4) ステンレス黒着色(BC4)	Black 黒
2		not to be given なし	White 白
3	Brass 黄銅	Regular nickel plating (NL) 普通ニッケルメッキ(NL)	White 白
4		Black nickel plating (BN) 黒色ニッケルメッキ(BN)	Black 黒
5	Steel 鋼	White zinc trivalent chromate treating (ZC3) 白色亜鉛3価クロメート(ZC3)	White 白
6		Regular nickel chromium plating (NC) 普通ニッケルクロムメッキ(NC)	White 白
7		Regular nickel plating (NL) 普通ニッケルメッキ(NL)	White 白
8		Iron and steel phosphating (P1) 鉄鋼磷酸塩処理(P1)	Black 黒
9		Black zinc trivalent chromate treating (BZ3) 黒色亜鉛3価クロメート(BZ3)	Black 黒

FIGURE ZZB MECHANICAL STANDARD PARTS (SCREWS)

1. Screws ねじ

How to read Parts Numbers
部品番号の見方

Screws
ねじ

XB1-2400-609

Type No.
類別番号

Normal designation (d)
ねじの呼び(d)

Length (L)
ねじの長さ(L)

Material and Surface treatment
材料および表面処理

XB1-2 expresses Binding head machine screw.
XB1-2は、バインドねじを表す

40 expresses M4.0.
40は、M4.0を表す

0-60 expresses a length of 6.0mm.
0-60は、6.0mmの長さを表す

9 expresses Steel (Black zinc trivalent chromate
treating) from Table 1.

9は、表1より鋼(黒色亜鉛3価クロメート)を表す

1-1. Cross Recessed Head Screws for Precision Equipments

精密機器用十字穴付き小ねじ

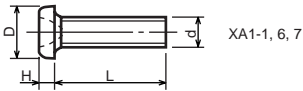

XA1-1, 6, 7

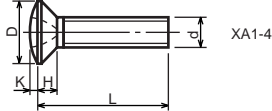

XA1-4

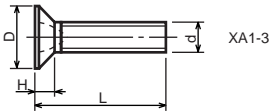

XA1-3

Type No. 類別番号	Type 類別
XA1-1	Pan head Class 1 なべ1種
XA1-3	Countersunk head Class 1 さら1種
XA1-4	Oval countersunk head Class 1 丸さら1種
XA1-6	Pan head Class 3 なべ3種
XA1-7	Pan head Class 2 なべ2種

		Head size (mm) 頭部寸法 (mm)					
		M1.4	M1.6	M1.7	M2	M2.5	M2.6
D	XA1-1	2	2.4	2.5	3	3.8	4
H	XA1-1	0.5	0.55	0.5	0.6	0.9	0.8
D	XA1-3	2	2.4	2.5	3	3.8	4
H	XA1-3	0.48	0.55	0.58	0.73	0.85	0.93
D	XA1-4	2	2.4	2.5	3	3.8	4
H + K	XA1-4	0.68	0.8	0.88	1	1.25	1.3
D	XA1-6	2.5	2.8	3	3.5	4.3	4.5
H	XA1-6	0.8	0.85	0.9	1	1.3	1.2
D	XA1-7	2.5	2.8	3	3.5	4.3	4.5
H	XA1-7	0.5	0.55	0.5	0.6	0.9	0.8

1-2. Precision Tapping Screws
精密用タッピンねじ

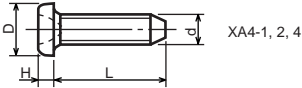

XA4-1, 2, 4

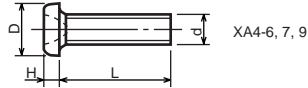

XA4-6, 7, 9

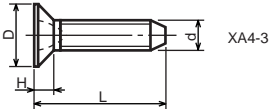

XA4-3

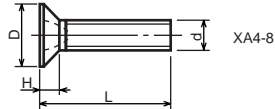

XA4-8

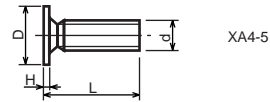

XA4-5

Type No. 類別番号	Type 類別	Head size (mm) 頭部寸法 (mm)						
		M1.4	M1.6	M1.7	M2	M2.5	M2.6	
XA4-1	With tapered end pan head Class 1 絞りなべ1種	D XA4-1	2	2.4	2.5	3	3.8	4
		H XA4-1	0.5	0.55	0.5	0.6	0.9	0.8
XA4-2	With tapered end pan head Class 3 絞りなべ3種	D XA4-2	2.5	2.8	3	3.5	4.3	4.5
		H XA4-2	0.8	0.85	0.9	1	1.3	1.2
XA4-3	With tapered end countersunk head 絞り-さら	D XA4-3	2	2.4	2.5	3	3.8	4
		H XA4-3	0.48	0.55	0.58	0.73	0.85	0.93
XA4-4	With tapered end pan head Class 2 絞りなべ2種	D XA4-4	2.5	2.8	3	3.5	4.3	4.5
		H XA4-4	0.5	0.55	0.5	0.6	0.9	0.8
XA4-5	With parallel end ultra thin head ストレート-超薄頭	D XA4-5	2.5	2.8	3	-	-	-
		H XA4-5	0.2	0.2	0.2	-	-	-
XA4-6	With parallel end pan head Class 1 ストレートなべ1種	D XA4-6	2	2.4	2.5	3	3.8	4
		H XA4-6	0.5	0.55	0.5	0.6	0.9	0.8
XA4-7	With parallel end pan head Class 3 ストレートなべ3種	D XA4-7	2.5	2.8	3	3.5	4.3	4.5
		H XA4-7	0.8	0.85	0.9	1	1.3	1.2
XA4-8	With parallel end countersunk head ストレート-さら	D XA4-8	2	2.4	2.5	3	3.8	4
		H XA4-8	0.48	0.55	0.58	0.73	0.85	0.93
XA4-9	With parallel end pan head Class 2 ストレートなべ2種	D XA4-9	2.5	2.8	3	3.5	4.3	4.5
		H XA4-9	0.5	0.55	0.5	0.6	0.9	0.8

1-3. Cross Recessed Head Screws
 一般用十字穴付き小ねじ



XB1-1

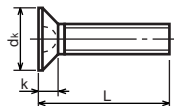

XB1-3

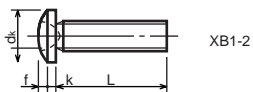

XB1-2

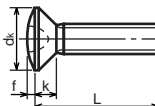

XB1-4

Type No. 類別番号	Type 類別
XB1-1	Pan head なべ
XB1-2	Binding head バインド
XB1-3	Countersunk head さら
XB1-4	Oval countersunk head 丸さら

		Head size (mm) 頭部寸法 (mm)					
		M2	M2.5	M2.6	M3	M4	M5
dk	XB1-1	3.5	4.5	4.5	5.5	7	9
k	XB1-1	1.3	1.7	1.7	2	2.6	3.3
dk	XB1-2	4.3	5.3	5.5	6.3	8.3	10.3
k+f	XB1-2	1.2	1.5	1.6	1.9	2.5	3.1
dk	XB1-3	4	5	-	6	8	10
k	XB1-3	1.2	1.45	-	1.75	2.3	2.8
dk	XB1-4	4	5	-	6	8	10
k+f	XB1-4	1.6	2	-	2.45	3.2	4
Screw part length ねじ部長さ b		8	12	12	12	16	20

1-4. Cross Recessed Head Screws with Captive Washer
座金組込み十字穴付き小ねじ

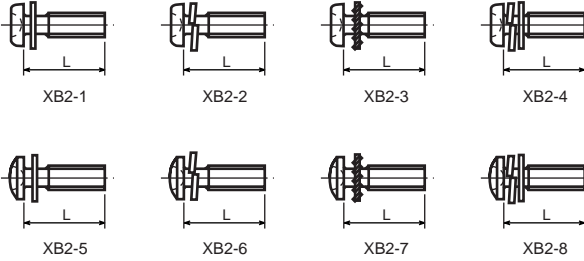

Type No. 類別番号	Type 類別
XB2-1	Pan head + Plain washer (circular bright) なべねじ+平座金
XB2-2	Pan head + Spring washer なべねじ+ばね座金
XB2-3	Pan head + Toothed lock washer なべねじ+歯付座金
XB2-4	Pan head + Spring washer and plain washer (circular bright) なべねじ+(ばね+平)座金
XB2-5	Binding head + Plain washer (circular bright) バインドねじ+平座金
XB2-6	Binding head + Spring washer バインドねじ+ばね座金
XB2-7	Binding head + Toothed lock washer バインドねじ+歯付座金
XB2-8	Binding head + Spring washer and plain washer (circular bright) バインドねじ+(ばね+平)座金

1-5. Hexagon Head Tapping Screws for Metallic Materials
 金属用六角タッピンねじ

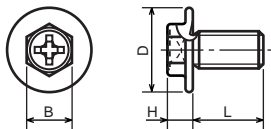

Type No. 類別番号	Type 類別	Head size (mm) 頭部寸法 (mm)	
		M3	M4
XB3-6	For metallic materials 金属用タッピン	D	8 10
		B	5.5 5.5
XB3-7	For metallic materials with clawed 金属用タッピン-つめ付き	H XB3-6	3.1 3.1
		H XB3-7	3.2 3.2

1-6. Special Tapping Screws
 特殊タッピンねじ

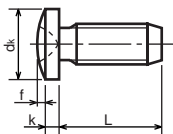

Type No. 類別番号	Type 類別	Head size (mm) 頭部寸法 (mm)	
		M3	M4
XB4-5	Binding head バインド	d _k	6.3 8.3
		k	1.3 1.7
		k+f	1.9 2.5

1-7. General Head Tapping Screws
一般用タッピンねじ

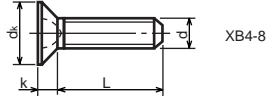
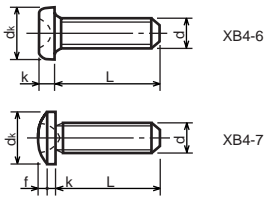

Type No. 類別番号	Type 類別	Head size (mm) 頭部寸法 (mm)						
		M2	M2.5	M2.6	M3	M4	M5	
XB4-6	Pan head なべ	d _k	3.5	4.5	4.5	5.5	7	9
		k	1.3	1.7	1.7	2	2.6	3.3
XB4-7	Binding head バインド	d _k	4.3	5.3	5.5	6.3	8.3	10.3
		k+f	1.2	1.5	1.6	1.9	2.5	3.1
XB4-8	Countersunk head さら	d _k	4	5	5.2	6	8	10
		k	1.2	1.45	1.5	1.75	2.3	2.8

1-8. Tapping Screws for Metallic Materials
金属用タッピンねじ

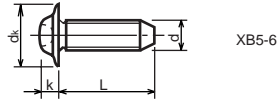
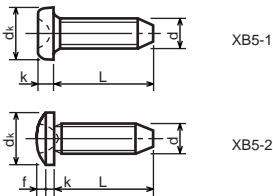

Type No. 類別番号	Type 類別	Head size (mm) 頭部寸法 (mm)					
		M2.5	M2.6	M3	M4	M5	
XB5-1	Pan head なべ	d _k	4.5	4.5	5.5	7	9
		k	1.7	1.7	2	2.6	3.3
XB5-2	Binding head バインド	d _k	5.5	5.5	6.3	8.3	10.3
		k+f	1.6	1.6	1.9	2.5	3.1
XB5-6	Flanged pan head つば付きなべ	d _k	6.5	6.5	8	10	12
		k	2.1	2.1	1.75	3.2	4

1-9. Hexagon Socket Set Screws
六角穴付止めねじ

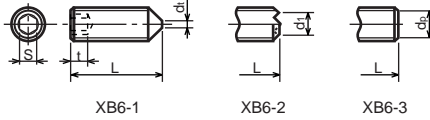

Type No. 類別番号	Type 類別	Head size (mm) 頭部寸法 (mm)							
		M1.6 M1.7	M2	M2.5 M2.6	M3	M5	M5	M6	
XB6-1	Cone point とがり先	S	0.7	0.9	1.3	1.5	2	2.5	3
		t	1.5	1.7	2	2	2.5	3	3.5
		$d_{t \max}$ XB6-1	0.4	0.5	0.65	0.75	1	1.25	1.5
		$d_{t \max}$ XB6-2	-	1.2	1.5	1.7	2.2	2.8	3.3
		$d_{t \min}$ XB6-2	-	1	1.2	1.4	1.9	2.4	2.9
		$d_{p \max}$ XB6-3	0.8	1	1.5	2	2.5	3.5	4
		$d_{p \min}$ XB6-3	0.55	0.75	1.25	1.75	2.25	3.2	3.7

1-10. Flanged Pan Head Machine Screws
つば付きなべ小ねじ

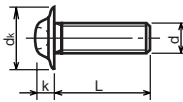

Type No. 類別番号	Type 類別	Head size (mm) 頭部寸法 (mm)					
		M2	M2.5 M2.6	M3	M5	M5	
XB6-7	Flanged pan head つば付きなべ	d_k	5	6.5	8	10	12
		k	1.7	2.1	2.5	3.2	4

FIGURE ZZC MECHANICAL STANDARD PARTS (BOLTS)

2. Bolts (Socket head cap screw) ボルト

How to read Parts Numbers
部品番号の見方

Bolt (Socket head cap screw)
ボルト

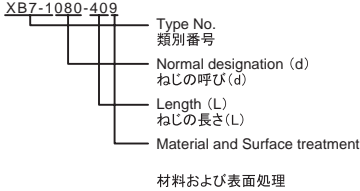

XB7-1 expresses Hexagon socket head cap screws.
XB7-1は、六角穴付きボルトを表す

080 expresses M8.0.
080は、M8.0を表す

40 expresses a length of 40mm.
40は、40mmの長さを表す

9 expresses Steel (Black zinc trivalent chromate treating) from Table 1.
9は、表1より鋼(黒色亜鉛3価クロメート)を表す

2-1. Hexagon socket head cap screws 六角穴付きボルト

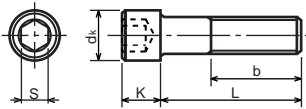

Type No. 類別番号	Type 類別
XB7-1	Hexagon socket head cap screws 六角穴付きボルト

	Head size (mm) 頭部寸法 (mm)						
	M3	M4	M5	M6	M8	M10	M12
S	2.5	3	4	5	6	8	10
d _k	5.5	7	8.5	10	13	16	18
K	3	4	5	6	8	10	12
Screw part length ねじ部長さ b _{max}	18	20	22	24	28	32	36

FIGURE ZZD MECHANICAL STANDARD PARTS (NUTS)

3. Nuts ナット

How to read Parts Numbers
部品番号の見方

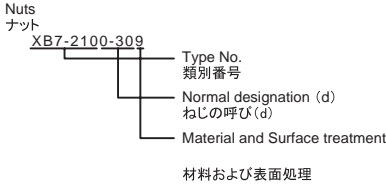

XB7-210 expresses Hexagon nut class 1.
XB7-210は、六角ナット1種を表す

0-30 expresses M3.0.
0-30は、M3.0を表す

9 expresses Steel (Black zinc trivalent chromate treating) from Table 1.

9は、表1より鋼(黒色亜鉛3価クロメート)を表す

3-1. Hexagon Nuts and Hexagon Thin Nuts 六角ナット

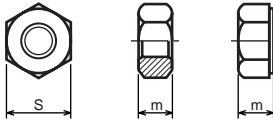

Type No. 類別番号	Type 類別
XB7-210	Hexagon nut Class 1 六角ナット-1種
XB7-220	Hexagon nut Class 3 六角ナット-3種
XB7-230	Hexagon nut Style 1 double chamfered 六角ナット-スタイル1-両面とり
XB7-231	Hexagon nut Style 1 washer faced 六角ナット-スタイル1-座付き
XB7-240	Hexagon nut Style 2 double chamfered 六角ナット-スタイル2-両面とり
XB7-241	Hexagon nut Style 2 washer faced 六角ナット-スタイル2-座付き
XB7-250	Hexagon nut 六角ナット
XB7-260	Hexagon thin nut double chamfered 六角低ナット-両面とり
XB7-270	Hexagon thin nut not chamfered 六角低ナット-面とり無し

	Head size (mm) 頭部寸法 (mm)						
	M2	M2.5	M3	M4	M5	M6	M8
S	4	5	5.5	7	8	10	13
m XB7-210	1.6	2	2.4	3.2	4	5	6.5
m XB7-220	1.2	1.6	1.8	2.4	3.2	3.6	5
m XB7-230, 231	1.6	2	2.4	3.2	4.7	5.2	6.8
m XB7-240, 241	-	-	-	-	5.1	5.7	7.5
m XB7-250	-	-	-	-	5.6	6.1	7.9
m XB7-260	1.2	1.6	1.8	2.2	2.7	3.2	4
m XB7-270	1.2	1.6	1.8	2.2	2.7	3.2	4

FIGURE ZZE MECHANICAL STANDARD PARTS (WASHERS)

4. Washers ワッシャ

How to read Parts Numbers
部品番号の見方

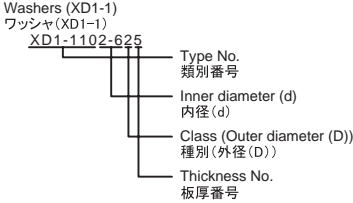

XD1-110 expresses copper material washer.
XD1-110は、銅材のワッシャを表す

2-6 expresses a inner diameter of 2.6 mm.
2-6は、2.6mmの内径を表す

2 expresses a outer diameter of 4.4 mm from Table 2.
2は、表2より4.4mmの外径を表す

5 expresses a thickness of 0.5 mm from Table 3.
5は、表3より0.5mmの板厚を表す

Table 2 表2

d (mm)	D (mm)		
	Class 1 1種	Class 2 2種	Class 3 3種
1.5	-	2.6	3.2
1.8	2.7	3.1	3.7
2.1	3.2	3.6	4.2
2.3	3.6	4	4.6
2.6	4	4.4	5
3.1	4.6	5	5.6
3.6	5.4	5.8	6.4
4.1	5.7	6.6	8
4.6	6.4	7.4	9
5.2	7.2	8.2	10
5.7	7.8	9	11
6.2	8.5	9.8	12
6.7	9.2	10.5	13
7.2	10	11.4	14
7.7	10.6	12.2	15
8.2	11.4	13	16
8.7	12	13.8	17
9.2	12.8	14.6	18
9.7	13.5	15.4	19
10.2	14.3	15.6	20

Table 3 表3

Thickness No. 板厚番号	t (mm)
0	0.05
1	0.1
2	0.2
3	0.3
4	0.4
5	0.5
6	0.6
7	0.7
8	0.8
9	1

Plain washers, Spring lock washers, Toothed lock washers (XD1-2, 3, 4)
平座金、ばね座金、歯付き座金 (XD1-2, 3, 4)

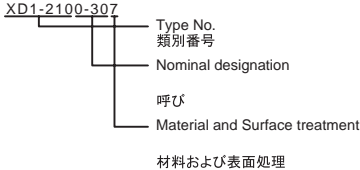

XD1-210 expresses plain washer.
XD1-210は、平座金を表す

0-30 expresses a 030 of nominal designation.
(See Table 4)

0-30は、呼び030を表す (表4参照)

7 expresses Steel (Regular nickel chromium plating)
from Table 1.

7は、表1より鋼 (普通ニッケルメッキ) を表す

4-1. Washers

ワッシャ

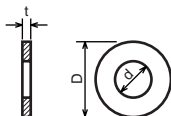

Type No. 類別番号	Type 類別
XD1-110	Washer - Copper material ワッシャ 銅
XD1-120	Washer - Stainless steel material ワッシャ ステンレス

4-2. Plain Washers

平座金

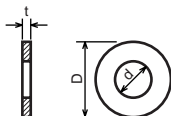

Type No. 類別番号	Type 類別
XD1-210	Regular type grade A 並形—等級A
XD1-120	Washer - Stainless steel material ワッシャ ステンレス

Table 4 表4

Nominal designation 呼び	d (mm)	D (mm)	t (mm)
020	2.2	5	0.3
025	2.7	6.5	0.5
026	2.8	6.5	0.5
030	3.2	7	0.5
040	4.3	9	0.8
050	5.3	10	1
060	6.4	12.5	1.6
080	8.4	17	1.6
100	10.5	21	2
120	13	24	2.5

4-3. Spring Lock Washers

ばね座金



Type No. 類別番号	Type 類別
XD1-310	No.2 2号

Table 4 表4

Nominal designation 呼び	d (mm)	D (mm)
020	2.1	4.4
025	2.6	5.2
026	2.7	6.5
030	3.1	5.3
040	4.1	5.9
050	5.1	9.2
060	6.1	12.2
080	8.2	15.4
100	10.2	18.4
120	12.2	21.5

4-4. Toothed Lock Washers
歯付き座金

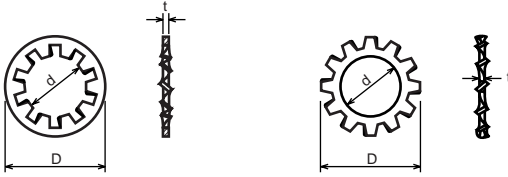

Type No. 類別番号	Type 類別
XD1-410	Internal tooth type 内歯形
XD1-420	External tooth type 外歯形

Table 4 表4

Nominal designation 呼び	d (mm)	D (mm)	t (mm)	No. of Int. tooth 内歯数	No. of Ext. tooth 外歯数
020	2.2	4.8	0.3	7	-
025	2.7	5.7	0.3	7	-
026	2.8	5.8	0.3	7	-
030	3.2	6.5	0.45	8	8
040	4.3	8.5	0.45	8	9
050	5.3	10	0.6	8	10
060	6.4	11	0.6	9	12
080	8.4	15	0.8	9	12

FIGURE ZZF MECHANICAL STANDARD PARTS (RETAINING RINGS)

5. Retaining Rings

止め輪

How to read Parts Numbers
部品番号の見方

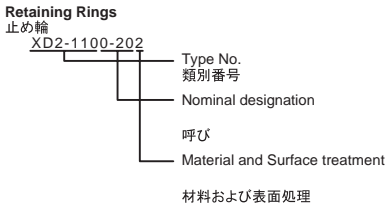

XD2-110 expresses retaining ring-E type (Type1).
XD2-110は、E形止め輪(1種)を表す

0-20 expresses a 020 of nominal designation.
(See Table 5)

0-20は、呼び020を表す(表5参照)

2 expresses Stainless steel (Surface treatment is not to be given) from Table 1.

2は、表1よりステンレス(表面処理なし)を表す

5-1. Retaining Rings - E type

E形止め輪

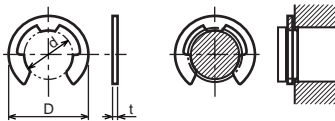

Type No. 類別番号	Type 類別
XD2-110	Retaining ring - E type (Type 1) E形止め輪(1種)
XD2-120	Retaining ring - E type (Type 2) E形止め輪(2種)

Table 5 表5

Type 種類	Nominal designation 呼び	d (mm)	D (mm)	t (mm)
Type 1 1種	007	0.65	2	0.2
	010	0.95	2.8	0.2
	013	1.25	3.3	0.3
	017	1.65	4.2	0.4
	020	1.95	4.6	0.5
	024	2.35	6	0.6
	028	2.74	6.5	0.6
	032	3.14	7.2	0.6
	037	3.64	8	0.7
	040	3.93	10	0.7
	042	4.13	10	0.7
	050	4.93	11	0.7
	058	5.73	12	0.7
	060	5.93	12.7	0.9
	064	6.32	13.5	0.9
	074	7.31	15	0.9
080	7.91	16.5	1	
Type 2 2種	008	0.8	2	0.2
	012	1.2	3	0.3
	015	1.5	4	0.4
	020	2	5	0.4
	025	2.5	6	0.4
	030	3	7	0.6
	040	4	9	0.6
	050	5	11	0.6
	060	6	12	0.8
	070	7	14	0.8
	080	8	16	0.8
	090	9	18	0.8
	100	10	20	1

5-2. Grip Rings
グリップ止め輪

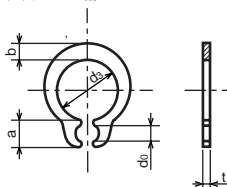

Type No. 類別番号	Type 類別
XD2-210	Grip ring グリップ止め輪

Table 5 表5

Nominal designation 呼び	d ₃ (mm)	t (mm)	b (mm)	a (mm)	d ₀ (mm)
020	1.9	0.5	1	1.8	0.8
025	2.35	0.5	1.2	1.9	0.9
030	2.85	0.6	1.4	1.9	0.9
035	3.3	0.6	1.6	2	0.9
040	3.8	0.8	1.8	2.8	1.2
045	4.25	0.8	2	2.9	1.3
050	4.75	0.8	2.2	2.9	1.3
060	5.7	1	2.4	3.1	1.4
070	6.7	1	2.7	3.3	1.4
080	7.7	1	3	3.5	1.4
090	8.65	1.2	3.3	4.7	1.5
100	9.65	1.2	3.5	4.7	2

5-3. Toothed Retaining Rings
歯付き形止め輪

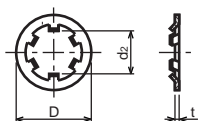

Type No. 類別番号	Type 類別
XD2-230	Toothed retaining ring 歯付き形止め輪

Table 5 表5

Nominal designation 呼び	d _z (mm)	D (mm)	t (mm)	No of teeth 歯数
015	1.4	5.2	0.25	3
020	1.9	6	0.25	3
024	2.3	6.4	0.25	3
030	2.8	8	0.25	4
040	3.8	9	0.25	4
050	4.8	10	0.25	5
060	5.8	11	0.25	5
080	7.8	13	0.25	5
100	9.8	15.4	0.25	6

5-4. Retaining Rings - C Type

C形止め輪

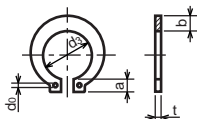

Type No. 類別番号	Type 類別
XD2-310	Retaining ring - C type for shaft C形止め輪 軸用

Table 5 表5

Nominal designation 呼び	d ₃ (mm)	t (mm)	b (mm)	a (mm)	d ₀ (mm)
010	9.3	1	1.6	3	1.2
012	11.1	1	1.8	3.2	1.5
014	12.9	1	2	3.4	1.7
015	13.8	1	2.1	3.5	1.7
016	14.7	1	2.2	3.6	1.7
017	15.7	1	2.2	3.7	1.7
018	16.5	1.2	2.6	3.8	1.7
020	18.5	1.2	2.7	3.9	2
022	20.5	1.2	2.7	4.1	2
025	23.2	1.2	3.1	4.3	2
028	25.9	1.5	3.1	4.6	2
030	27.9	1.5	3.5	4.8	2
032	29.6	1.5	3.5	5	2.5
035	32.2	1.5	4	5.4	2.5

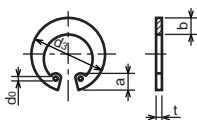

Type No. 類別番号	Type 類別
XD2-320	Retaining ring - C type for hole C形止め輪 穴用

Table 5 表5

Nominal designation 呼び	d ₃ (mm)	t (mm)	b (mm)	a (mm)	d ₀ (mm)
010	10.7	1	1.8	3.1	1.2
011	11.8	1	1.8	3.2	1.2
012	13	1	1.8	3.3	1.5
014	15.1	1	2	3.6	1.7
016	17.3	1	2	3.7	1.7
018	19.5	1	2.5	4	1.7
019	20.5	1	2.5	4	2
020	21.5	1	2.5	4	2
022	23.5	1	2.5	4.1	2
025	26.9	1.2	3	4.4	2
028	30.1	1.2	3	4.6	2
030	32.1	1.2	3	4.7	2
032	34.4	1.2	3.5	5.2	2.5
035	37.8	1.5	3.5	5.2	2.5
037	39.8	1.5	3.5	5.2	2.5
040	43.5	1.8	4	5.7	2.5
042	45.5	1.8	4	5.8	2.5
045	48.5	1.8	4.5	5.9	2.5
047	50.5	1.8	4.5	6.1	2.5
050	54.2	2	4.5	6.5	2.5
052	56.2	2	5.1	6.5	2.5
055	59.2	2	5.1	6.5	2.5
060	64.2	2	5.1	6.8	2.5
062	66.2	2	5.5	6.9	2.5
068	72.5	2.5	6	7.4	2.5
072	76.5	2.5	6.6	7.4	2.5
075	79.5	2.5	6.6	7.8	2.5
080	85.5	2.5	7	8	2.5
085	90.5	3	7	8	3
090	95.5	3	7.6	8.3	3
095	100.5	3	8	8.5	3

FIGURE ZZG MECHANICAL STANDARD PARTS (PINS)

6. Pins ピン

How to read Parts Numbers
部品番号の見方

Pins
ピン

XD3-1200-122

Type No.
類別番号
Nominal diameter (d)
呼び径 (d)
Length (L)
長さ (L)
Material and Surface treatment
材料および表面処理

XD3-1 expresses spring pins for general use.
XD3-1は、スプリングピン(一般用)を表す

20 expresses a nominal diameter of 2.0 mm.
20は、2.0mmの呼び径を表す

0-12 expresses a length of 12 mm.
0-12は、12mmの長さを表す

2 expresses Stainless steel (Surface treatment is not to be given) from Table 1.
2は、表1よりステンレス(表面処理なし)を表す

6-1. Springs Pins スプリングピン

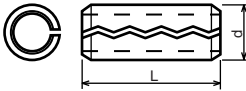

Type No. 類別番号	Type 類別
XD3-0	Spring pin for light load スプリングピン(軽荷重用)
XD3-1	Spring pin for general use スプリングピン(一般用)

6-2. Parallel Pins 平行ピン

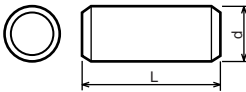

Type No. 類別番号	Type 類別
XD3-2	Parallel pin (h7 hard) 平行ピン(h7硬質)
XD3-4	Parallel pin (m6 soft) 平行ピン(m6軟質)

6-3. Taper Pins テーパピン

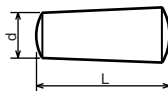

Type No. 類別番号	Type 類別
XD3-3	Taper pin テーパピン

FIGURE ZZH MECHANICAL STANDARD PARTS (SPACERS)

7. Spacers スペーサ

How to read Parts Numbers
部品番号の見方

Spacers スペーサ

XZ1-1301-005

Type No.
類別番号

Nominal diameter (d)
呼び径 (d)

Length (L)
長さ(L)

Material and Surface treatment

材料および表面処理

XZ1-1 expresses spacers.
XZ1-1は、スペーサを表す

30 expresses a nominal diameter of 3.0 mm.
30は、3.0mmの呼び径を表す

1-00 expresses a length of 10 mm.
1-00は、10mmの長さを表す

5 expresses Steel (White zinc trivalent chromate
treating) from Table 1.

5は、表1より鋼(白色亜鉛3価クロメート)を表す

7-1. Spacers スペーサ

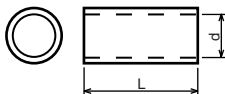

Type No. 類別番号	Type 類別
XZ1-1	Spacers スペーサ

INNER 2WAY TRAY-E2 (Parts Catalog)

INNER 2WAY TRAY-E2

F28-0145-000 MYH

NUMERICAL INDEX

INNER 2WAY TRAY-E2(Numerical Index)

PARTS NUMBER	FIGURE & KEY NO.	PARTS NUMBER	FIGURE & KEY NO.	PARTS NUMBER	FIGURE & KEY NO.
4A3-1968-000	Q01 - 1				
FB6-1494-000	Q38 - 1				
FB6-1537-000	Q38 - 2				
FB6-1540-000	Q38 - 16				
FC6-4499-000	Q01 - 9				
FC6-4500-000	Q01 - 10				
FC6-5061-000	Q38 - 15				
FC6-6728-000	Q38 - 4				
FC6-6729-000	Q38 - 5				
FC6-6731-000	Q38 - 6				
FC6-6732-000	Q38 - 7				
FC6-6733-000	Q38 - 8				
FC6-6734-000	Q38 - 9				
FC6-6739-000	Q38 - 10				
FC6-6740-000	Q38 - 11				
FC6-6742-000	Q38 - 12				
FC6-6743-000	Q01 - 2				
FC6-6744-000	Q01 - 3				
FC6-6745-000	Q01 - 4				
FC6-6746-000	Q01 - 5				
FC6-6748-000	Q38 - 13				
FC8-0141-000	Q01 - 3				
FG6-8271-000	Q38 - 14				
FL2-3737-000	Q38 - 3				
FL2-3739-000	Q38 - 17				
FL2-3740-000	Q01 - 6				
FL2-3741-000	Q38 - 29				
FM2-4434-000	Q01 - 11				
FM2-4525-000	Q38 - 18				
FM2-4526-000	Q38 - 19				
FM2-4527-000	Q38 - 20				
FM3-3016-000	Q38 - 19				
FU5-8690-000	Q01 - 8				
FU6-0928-000	Q38 - 21				
FU6-0929-000	Q38 - 22				
FU6-2376-000	Q38 - 23				
FU6-2377-000	Q38 - 24				
FU6-2379-000	Q38 - 25				
FU6-8455-000	Q01 - 8				
NPN	Q01 -				
NPN	Q38 -				
VS1-7177-002	Q38 - 26				
WG8-5696-000	Q01 - 7				
WG8-5696-000	Q38 - 27				
XA9-1116-030	Q38 - 28				
XB4-5401-007	Q01 - 501				
XB4-5401-007	Q38 - 501				
XB6-7300-609	Q01 - 502				

FIGURE QA ASSEMBLY LOCATION DIAGRAM

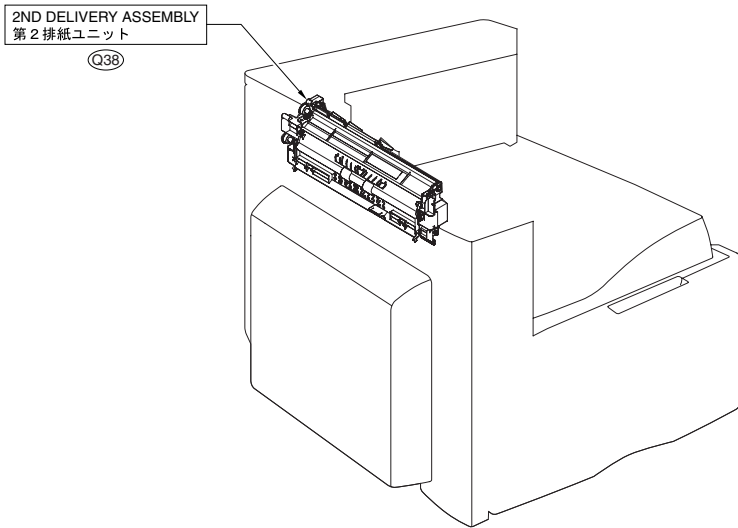

FIGURE Q01 PACKING KIT

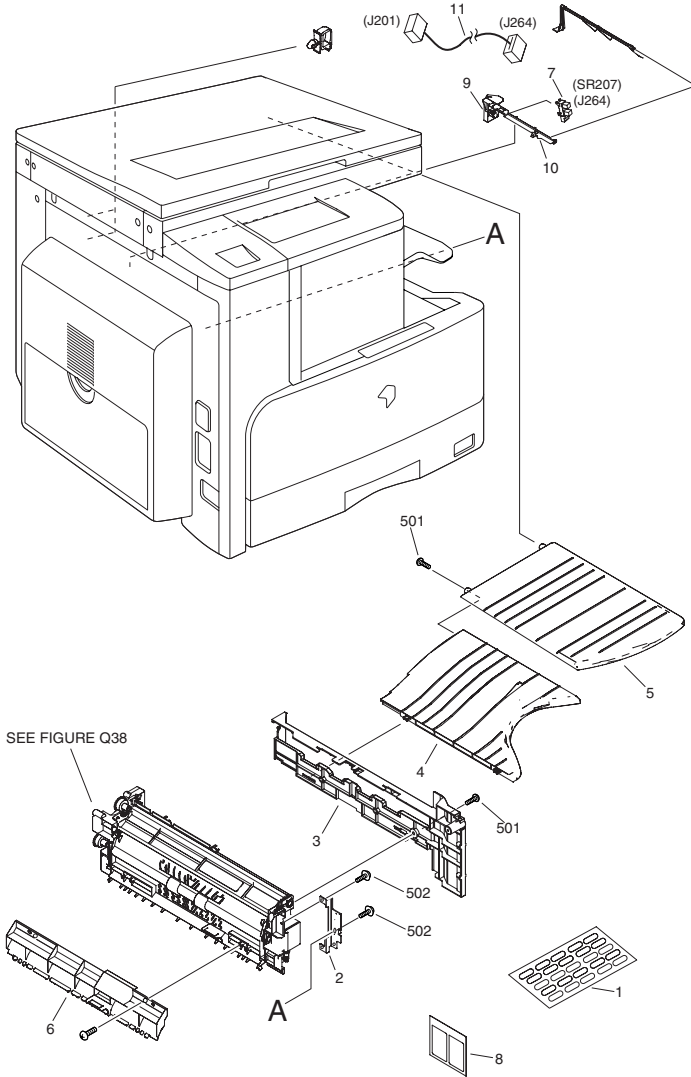

FIGURE & KEY NO.	PARTS NUMBER	R A N K	Q'TY	DESCRIPTION	SERIAL NUMBER/ REMARKS	S V C
Fig.Q01	NPN		RF	PACKING KIT		
1	4A3-1968-000		1	LABEL, TRAY INDICATION		
2	FC6-6743-000		1	PLATE, RETAINER		
3	FC6-6744-000		1	COVER, DELIVERY	E1	
3	FC8-0141-000		1	COVER, DELIVERY	E2	
4	FC6-6745-000		1	TRAY, DELIVERY, 1		
5	FC6-6746-000		1	TRAY, DELIVERY, 2		
6	FL2-3740-000		1	GUIDE, SUPPORT, 1		
7	WG8-5696-000		1	PHOTO INTERRUPTER, TLP1243	SR207 J264	
8	FU5-8690-000		1	LABEL, JAM CLEAR	E1	
8	FU6-8455-000		1	LABEL, JAM CLEAR	E2	
9	FC6-4499-000		1	LEVER, SENSOR		
10	FC6-4500-000		1	HOLDER, SENSOR		
11	FM2-4434-000		1	CABLE, SENSOR	J201,264	
501	XB4-5401-007		4	SCREW, M4X10		
502	XB6-7300-609		4	SCREW, MACH,PAN HEAD, M3X8		

FIGURE Q38 2ND DELIVERY ASSEMBLY

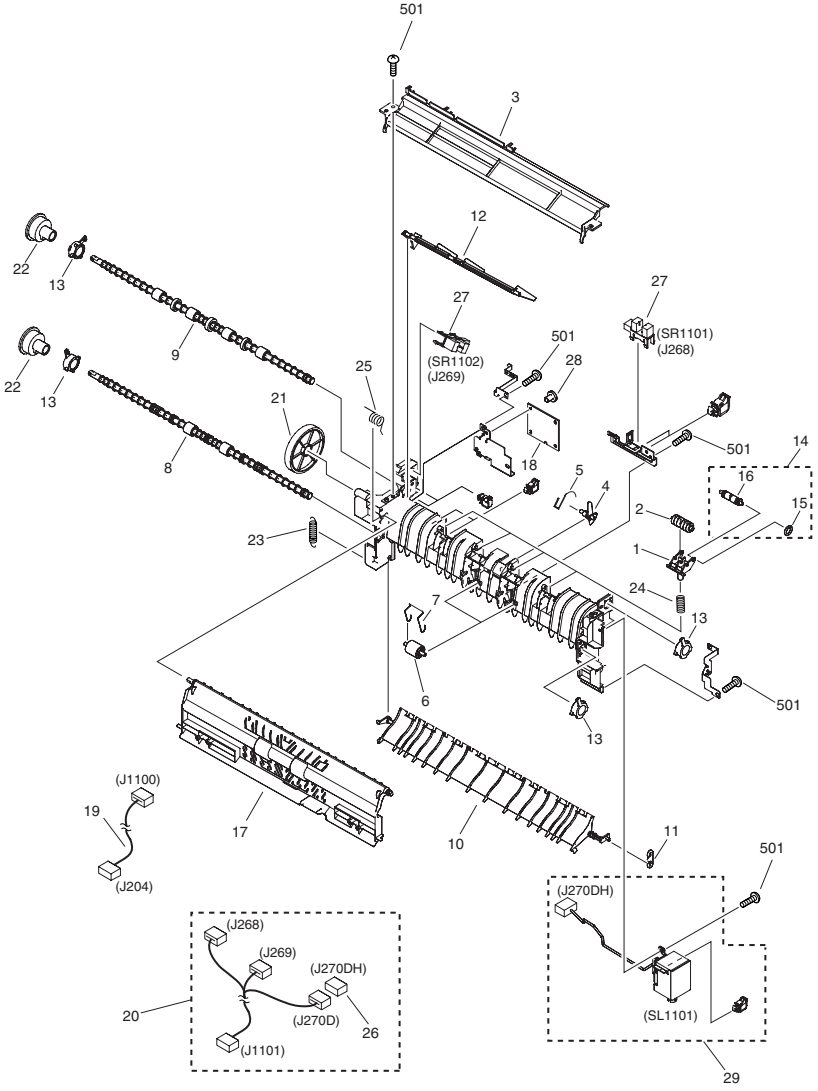

FIGURE & KEY NO.	PARTS NUMBER	R A N K	Q'TY	DESCRIPTION	SERIAL NUMBER/ REMARKS	S V C
Fig.Q38	NPN		RF	2ND DELIVERY ASSEMBLY		
1	FB6-1494-000		4	HOLDER, DELIVERY ROLLER		
2	FB6-1537-000		4	ROLLER		
3	FL2-3737-000		1	GUIDE, DELIVERY, UPPER		
4	FC6-6728-000		1	FLAG, DELIVERY SENSOR		
5	FC6-6729-000		1	SPRING, TORSION		
6	FC6-6731-000		2	COLLAR, DELIVERY		
7	FC6-6732-000		2	SPRING, TORSION		
8	FC6-6733-000		1	ROLLER, FEEDER		
9	FC6-6734-000		1	ROLLER, DELIVERY		
10	FC6-6739-000		1	DEFLECTOR		
11	FC6-6740-000		1	PLATE, LINK		
12	FC6-6742-000		1	LEVER, SENSOR		
13	FC6-6748-000		4	BUSHING		
14	FG6-8271-000		4	ROLLER, DELIVERY		
15	FC6-5061-000		1	RING		
16	FB6-1540-000		1	ROLLER		
17	FL2-3739-000		1	GUIDE, DELIVERY		
18	FM2-4525-000		1	DELIVERY DRIVER PCB ASS'Y		
19	FM2-4526-000		1	CABLE, DELIVERY UNIT	E1J51,204,1101	
19	FM3-3016-000		1	CABLE, DELIVERY UNIT	E2	
20	FM2-4527-000		1	CABLE, DERIVER SENSOR	J268,269,270D,1101	
21	FU6-0928-000		1	GEAR, 58T		
22	FU6-0929-000		2	GEAR, 17T		
23	FU6-2376-000		1	SPRING, TENSION		
24	FU6-2377-000		4	SPRING, COMPRESSION		
25	FU6-2379-000		1	SPRING, TORSION		
26	VS1-7177-002		1	CONNECTOR, SNAP TIGHT, BK	J270DH	
27	WG8-5696-000		2	PHOTO INTERRUPTER, TLP1243	SR1101,1102	
28	XA9-1116-030		2	SCREW, M3X5		
29	FL2-3741-000		1	MOUNT, SOLENOID	SL1101	
501	XB4-5401-007		8	SCREW, M4X10		

Card Reader-E1 (Parts Catalog)

Card Reader-E1

F25-9422-000 XJF

NUMERICAL INDEX

Card Reader-E1(Numerical Index)

PARTS NUMBER	FIGURE & KEY NO.	PARTS NUMBER	FIGURE & KEY NO.	PARTS NUMBER	FIGURE & KEY NO
FB3-8873-000	E10 - 1				
FC1-8289-000	E10 - 2				
FC3-1277-000	E10 - 3				
FF3-2302-000	E10 - 5				
FG6-8478-000	E10 - 6				
FH5-3317-000	E10 - 4				
NPN	E10 -				
XB1-2300-807	E10 - 503				
XB4-6261-209	E10 - 504				
XB6-7301-206	E10 - 501				
XB7-2200-307	E10 - 505				
XD1-4100-302	E10 - 502				
XD1-4100-402	E10 - 506				

FIGURE E10 CARD READER-E1

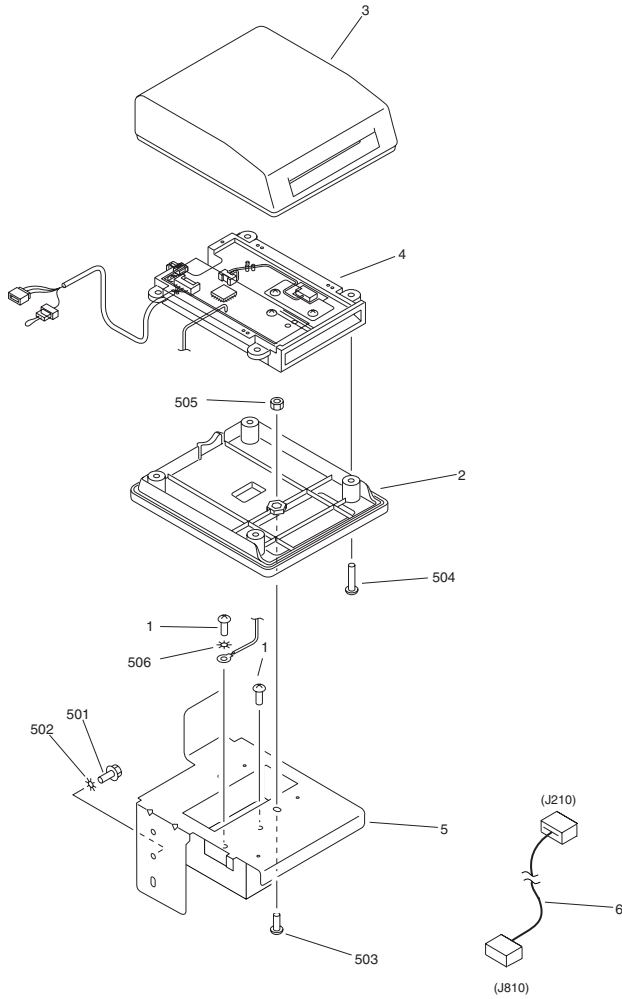

FIGURE & KEY NO.	PARTS NUMBER	R A N K	Q'TY	DESCRIPTION	SERIAL NUMBER/ REMARKS	S V C
Fig.E10	NPN		RF	CARD READER-E1		
1	FB3-8873-000		2	SCREW, ROUND END, M4X4		
2	FC1-8289-000		1	COVER, LOWER		
3	FC3-1277-000		1	PANEL, CONTROL CARD		
4	FH5-3317-000		1	CARD READER UNIT		
5	FF3-2302-000		1	MOUNT, CONTROL CARD		
6	FG6-8478-000		1	CABLE, CARD-IP	J210,810	
501	XB6-7301-206		1	SCREW, RS, M3X12		
502	XD1-4100-302		1	TOOTHED LOCK WASHER		
503	XB1-2300-807		1	SCREW, CROSS-RECESS, FCH		
504	XB4-6261-209		4	SCREW, SELF-TAPPING, M2.6X12		
505	XB7-2200-307		1	NUT, M3		
506	XD1-4100-402		1	TOOTHED LOCK WASHER(SUS)		

Document Tray-J1 (Parts Catalog)

Document Tray-J1

F31-9751-000

NUMERICAL INDEX

Document Tray-J1(Numerical Index)

PARTS NUMBER	FIGURE & KEY NO.	PARTS NUMBER	FIGURE & KEY NO.	PARTS NUMBER	FIGURE & KEY NO
FB6-5450-000	G10 - 1				
FB6-5451-000	G10 - 2				
FS5-9161-020	G10 - 3				
NPN	G10 -				
XA9-1301-000	G10 - 4				
XB4-7300-609	G10 - 501				
XD1-1108-239	G10 - 502				

FIGURE G10 DOCUMENT TRAY ASSEMBLY

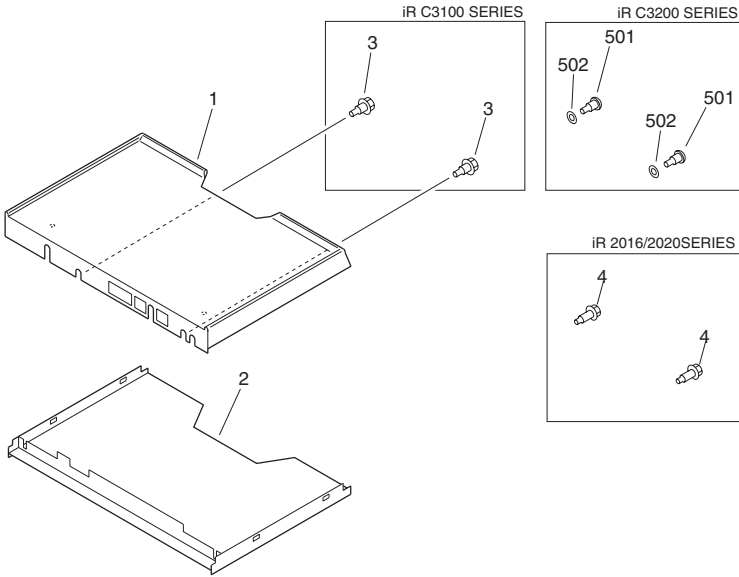

FIGURE & KEY NO.	PARTS NUMBER	RANK	QTY	DESCRIPTION	SERIAL NUMBER/REMARKS	SVC
Fig,G10	NPN		RF	DOCUMENT TRAY		
1	FB6-5450-000		1	TRAY, DOCUMENT, UPPER	iR C3100 SERIES	
2	FB6-5451-000		1	TRAY, DOCUMENT, LOWER	iR2016/2020 SERIES	
3	FS5-9161-020		2	SCREW, STEPPED, M4	iR C3200 SERIES	
4	XA9-1301-000		2	SCREW, RS STEPPED, M4	iR C3200 SERIES	
501	XB4-7300-609		2	SCREW,TAPPING,TRUSS HEAD,M3X6	iR C3200 SERIES	
502	XD1-1108-239		2	SHIM	iR C3200 SERIES	

Serial Interface Board-A2 (Parts Catalog)

Serial Interface Board-A2

F68-0169-000

NUMERICAL INDEX

Serial Interface Board-A2(Numerical Index)

PARTS NUMBER	FIGURE & KEY NO.	PARTS NUMBER	FIGURE & KEY NO.	PARTS NUMBER	FIGURE & KEY NO
FK2-0949-000 FM2-4062-000	G10 - IC G10 -				

FIGURE G10 SERIAL PCB ASSEMBLY

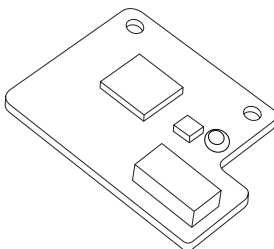

FIGURE & KEY NO.	PARTS NUMBER	RANK	Q'TY	DESCRIPTION	SERIAL NUMBER/REMARKS	SVC
Fig.G10	FM2-4062-000		1	SERIAL PCB ASSEMBLY		
IC	FK2-0949-000		1	IC, UPD65942GC-Y24.ASIC	IC1	

Serial Interface Kit-H1 (Parts Catalog)

Serial Interface Kit-H1

F68-0168-000

NUMERICAL INDEX

Serial Interface Kit-H1(Numerical Index)

PARTS NUMBER	FIGURE & KEY NO.	PARTS NUMBER	FIGURE & KEY NO.	PARTS NUMBER	FIGURE & KEY NO
FM3-3019-000	T01 - 1				
FM3-3326-000	T01 - 2				
NPN	T01 -				
XB6-7300-805	T01 - 501				

FIGURE T01 SERIAL INTERFACE KIT

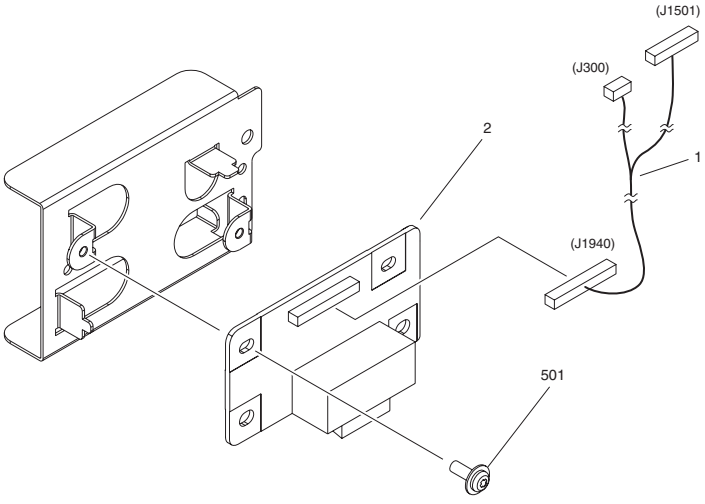

FIGURE & KEY NO.	PARTS NUMBER	RANK	Q'TY	DESCRIPTION	SERIAL NUMBER/REMARKS	SVC
Fig.T01	NPN		RF	SERIAL INTERFACE KIT		
1	FM3-3019-000		1	CABLE, COIN VENDER		
2	FM3-3326-000		1	CONVERSION BOARD PCB ASS'Y		
501	XB6-7300-805		2	SCREW, BH3X8 S		

Canon