

EPSON

DFX8000

Page 1

REF	PART NO	DESCRIPTION	SPEC	QTY
100	1014984	HOUSING ASSY.,LOWER		1
101	1026394	FRAME ASSY.,BOTTOM		1
102	1001041	COVER ASSY.,FRONT		1
103	1015012	HOUSING ASSY.,UPPER		1
104	1014990	HOUSING ASSY.,TOP		1
105	1014163	LOGO PLATE;B		1
105	1014926	LOGO PLATE		1
106	1001078	COVER, PAPER SUPPORT		1
108	1014800	COVER,REAR		1
109	1001858	MAGNET SUB ASSY.,LOWER		1
110	1015011	HOUSING SUB ASSY.,TOP		1
111	F346559080	CIRCUIT BOARD HOLDER		1
112	1001860	MAGNET SUB ASSY.,TOP		1
113	F346559100	MECHANISM MOUNTING SCREW		4
114	F346559120	TOP COVER HINGE SCREW		4
115	1001070	HOLDER,CONTROL PANEL		1
116	1001071	HOUSING,LEFT		1
117	1001073	HOUSING,RIGHT		1
118	1001861	COVER,TOP,SUB ASSY.		1
119	1001862	COVER,PUSH TRACTOR SUB ASSY.		1
120	1001863	PAPER SUPPORT SUB ASSY.		1
121	1023598	MOUNT,INTER LOCK		1
122	1001056	SHIELD PLATE		1
123	1001321	C.B.S.(O) SCREW	M3X8	3
124	1001322	C.B.(O) SCREW	M4X6	1
125	B030103811	C.P. SCREW WITH S/W	M3X16	2
126	B300704411	C.F.S.SCREW	M3X10	2
127	B310204311	C.B.B. SCREW	M3X8	3
128	1001319	C.B.B.(O) SCREW	M3X12	2
131	B310204411	C.B.B. SCREW	M3X10	3
132	B310204511	C.B.B. SCREW	M3X12	16
133	B310206311	C.B.B.SCREW	M4X10	6
134	B310206611	C.B.B. SCREW	M4X16	24
136	B303406211	C.B.S.(O) SCREW	M4X8	4
137	B300104211	C.P.S. SCREW	M3X6	2
139	B310204412	C.B.B. SCREW	M3X10	4
140	1001323	C.F.B. SCREW	M3X10	5
142	1002993	METAL,TRANSPORT,FIX,LEFT		1
143	F346559160	TRANSPORT LOCKING BRACKET		1
144	2025175	FERRITECORE		1
145	2030194	FERRITE CORE		1
146	2015055	FERRITE CORE		2
147	B303404211	C.B.S.(O) SCREW	M3X6	2
200	2008892	BOARD ASSY.,MAIN&I/F	FOR EUROPE,S.E.ASIA,OCEAN	1
201	1001464	SHIELD PLATE C-850		1
202	Y475002001	COVER.CONNECTOR		1
205	2000025	WIRE-HARNESS 2000025		1
221	B040303011	C.C. SCREW	M3X12	6
222	B300204211	C.B.S. SCREW	M3X6	7
223	1001321	C.B.S.(O) SCREW	M3X8	4
224	B300304411	C.C.S. SCREW	M3X10	4
230	2000793	FAN		1
220	2000111	BOARD ASSY.,POWER SUPPLY	FOR OTHERS (220/240V)	1
221	B040303011	C.C. SCREW	M3X12	6

EPSON

DFX8000

Page 2

REF	PART NO	DESCRIPTION	SPEC	QTY
222	B300204211	C.B.S. SCREW	M3X6	7
223	1001321	C.B.S.(O) SCREW	M3X8	4
224	B300304411	C.C.S. SCREW	M3X10	4
230	2000793	FAN		1
220	2024411	BOARD ASSY., POWER SUPPLY	220V	1
300	2015157	BOARD ASSY.,DRVER		1
301	B010304218	C.B SCREW	3X35 F/ZB	4
302	1001275	C.B.(C) SCREW	3X10	2
450	2000789	CONTROL PANEL		1
401	2006741	POWER CABLE,BS31303SA-SR-10A	240V	1
411	2000026	WIRE-HARNESS		1
412	2000027	WIRE-HARNESS		1
413	2000028	WIRE-HARNESS		1
414	2018282	HARNESS		1
416	2000711	WIRE-HARNESS		1
417	2000729	WIRE-HARNESS		1
418	2000788	LEAD WIRE		3
500	2000115	PRINTER MECHANISM		1
N/A	X620900621	INTERLOCK MICROSWITCH		
N/A	1001053	COVER FOR DIP SWITCHES		
501	1000923	FRAME ASSY.,LEFT		1
502	1016906	FRAME ASSY.,RIGHT		1
503	2000827	SOLENOID ASSY.,LD		1
504	F346051001	PLATEN GAP ADJUSTMENT MOTOR	DC35V/0.7A	1
505	2022532	MOTOR SUB ASSY.,CR	DC20.3V/29.8W	1
506	1000450	FRAME,LOWER		1
507	1016899	FRAME,FRONT		1
508	F346056000	PAPER FEED MOTOR	DC35V(MAX)/52.5W	1
509	1000926	PULLEY ASSY.,BELT		1
510	F346102000	TENSION PULLEY ASSEMBLY		1
511	F346105000	RIBBON FEED MOTOR FRAME		1
512	F346106000	TRACTOR SELECT DETECTOR		1
513	F346107000	RIBBON FEED MOTOR	DC35V/5W	1
514	F346108000	RIBBON FEED SELECT GEAR		1
515	1042838	TRACTOR SELECT LEVER A		1
516	1017062	TRACTOR SELECT LEVER LOWER		1
517	1042665	SPRING,CHANGE,TRACTOR		1
518	F346104040	TRACTOR SELECT CAM		1
519	F346104050	TRACTOR SELECT TRANSMISSION GEAR		1
520	F346104060	RIBBON FEED TRANSMISSION GEAR		1
521	F346151000	PAPER THICKNESS DETECTOR		1
522	1001317	SENSOR ASSY.,HP		1
523	1001346	DETECTOR ASSY.,PULL TRACTOR		1
524	1000485	PAPER GUIDE,UPPER		1
525	1000928	CR ASSY.		1
526	1044878	RIBBON MASK SUB ASSY.,ASP		1
527	F346203000	BELT PULLEY HOLDER		1
528	1000930	PLATEN ASSY.		1
529	2000718	BOARD ASSY.,HEAD		1
530	2000794	BOARD ASSY.,DRIVE,TERMINAL		1
531	2000808	BOARD ASSY.,INTERMIT		1
532	1000932	PAPER ASSY.,SUPPORT		1
533	1000933	ROLLER ASSY.,LOAD		1
534	1016011	ANTI-STATIC BRUSH		1

EPSON

DFX8000

Page 3

REF	PART NO	DESCRIPTION	SPEC	QTY
535	2000811	DETECTOR ASSY.,PE,UPPER		1
536	B030101711	C.P.S.SCREW	M2X10	1
537	2000180	HARNESS,CUTTER		1
538	1039685	HODLER,CR MOTOR		1
539	1016900	MOUNT PLATE,CR MOTOR		1
540	2017404	DETECTOR,INTER LOCK	2.5,30V,6A,	1
541	2010394	FAN		1
545	1024964	WIRE BAND		2
546	2000827	SOLENOID ASSY.,LD		1
547	1019891	TRACTOR SUB ASSY.,FRONT,LEFT		1
548	1019883	TRACTOR SUB ASSY.,FRONT,RIGHT		1
549	F346259010	PAPER SUPPORT		4
550	F346259020	TRACTOR SHAFT		2
551	F346259030	TRACTOR GUIDE SHAFT		2
552	1042366	FRAME ASSY.,PF		1
553	1019892	TRACTOR SUB ASSY.,REAR,RIGHT		1
554	1019886	TRACTOR SUB ASSY.,REAR,LEFT		1
555	1000500	SPACER,PF ROLLER		4
556	1019991	ROLLER,PF,DRIVE		1
557	1000499	SPUR GEAR	18	1
558	1000513	SHAFT,CR,GUIDE,REAR		1
559	1000453	SHAFT,CR,GUIDE,FRONT		1
560	F346003050	CARRIAGE GUIDE SHAFT GEAR		1
561	F346003061	GUIDE SHAFT HOLDING LEVER (LEFT)		1
562	1015451	LEVER,SHAFT,RIGHT		1
563	F346003080	GUIDE SHAFT HOLDING SPRING		2
564	1000451	LEVER,G,ADJUST		1
565	F346003100	PAPER GAP ADJUSTMENT MIDDLE GEAR		1
566	1000458	COVER,FAN		1
567	1000452	COVER,CONNECTOR		1
568	1000455	DAMPER,LEFT		1
569	1018356	DAMPER,RIGHT		1
570	1000456	DAMPER,LOWER		4
571	1020360	OIL PAD COVER		2
572	F346003200	OIL PAD RING		2
573	1016903	FRAME,HEAD CABLE		1
574	1018094	COVER,HEAD CABLE		1
575	1040072	SHAFT,FASTEN,HOLDER		1
576	1000477	TIMING BELT,CR		1
577	1000478	HOLDER,BELT FASTEN		1
578	F346003240	OIL PAD		1
579	1000487	FRAME,PAPER GUIDE MOUNT		1
580	1000505	EXTENSION SPRING,1000		2
581	1000486	PAPER GUIDE,LOWER		3
582	1001797	SHEET,HEAD CABLE,PROTECT		1
584	F346003340	PLATEN ROLLER GEAR		1
585	F346003350	PLATEN ROLLER SHAFT HOLDER		10
586	F346003360	PLATEN ROLLER REDUCTION GEAR		1
587	F346003371	PLATEN ROLLER TRANSMISSION GEAR		1
588	F346003380	PLATEN ROLLER MIDDLE GEAR		1
589	F346003390	TENSION ROLLER GEAR		1
590	F346003400	PAPER BAIL GEAR		1
591	F346003410	PAPER BAIL LEVER		2

EPSON

DFX8000

Page 4

REF	PART NO	DESCRIPTION	SPEC	QTY
593	1000497	TIMING BELT,PF		1
594	F346003441	TRACTOR GEAR		2
595	F346003450	PAPER FEED REDUCTION GEAR		1
596	F346003460	PAPER FEED MIDDLE GEAR		4
597	F346003471	TRACTOR SELECT GEAR HOLDER		1
598	F346003490	TENSION PULLEY SPRING		1
599	F346003500	RIBBON FEED TRANSMISSION GEAR		1
601	B100152212	PLAIN WASHER	4X0.8X10	5
602	B040550411	C.P.S.P.SCREW	M3X6	9
603	1001830	C.P.(C),(S) SCREW	M4X10	7
604	B302004211	C.P.S.(P) SCREW	M3X6	9
605	B047100111	C.P.(PS) SCREW	M4X6	4
606	B302004311	C.P.(P) SCREW	3X8	2
607	1002363	C.P.S.(P.S) SCREW	M4X10	4
608	B047100211	C.P.(PS) SCREW	M4X8	12
611	B100150412	PLAIN WASHER	4X0.2X6	1
612	B303406211	C.B.S.(O) SCREW	M4X8	14
613	B100167090	PLAIN WASHER	4.1X0.2X7.8	2
614	B150300611	RETAINING RING	TYPE-E(3)	6
615	B101253890	LEAF SPRING	4.1X0.13X8.3	1
616	B081800111	H.N.F.	M4	4
617	1001091	FLANGE NUT		2
618	B302704311	C.P.S.(P.S) SCREW	M3X8	2
619	B150300911	RETAINING RING	TYPE-E(6)	11
620	1001828	C.B.S.(O) SCREW	M4X6	6
621	B101253390	LEAF SPRING	8.2X0.15X15	5
622	B100166012	PLAIN WASHER	8X0.5X15	4
623	1001188	WIRE HOLDER		2
624	B041050511	C.P.(P).SCREW	M3X6	1
625	F346003511	RIBBON FEED DRIVE GEAR		1
626	F346003520	RIBBON FEED GEAR COVER		1
627	1001189	CABLE CLIP		2
627	1001809	LOCKING WIRE SADDLE		2
628	1001809	LOCKING WIRE SADDLE		1
630	B030101711	C.P.S.SCREW	M2X10	1
631	B100152212	PLAIN WASHER	4X0.8X10	2
632	B302404211	C.P.S.(O) SCREW	M3X6	2
633	1025014	C.P.S(P.S) SCREW,3X10,F/ZN		2
634	1040327	METAL FITTINGS,FASTEN,SHAFT		1
635	B040451511	C.P.O SCREW	M4X5	1
636	1013589	SPACER,TIMING BELT		1
638	1019992	SHEET,DUST PROOF		1
650	1037283	PRINT HEAD KIT,FOR AFTER SERVICE		1
656	1019843	LEVER,TENSION,CANCEL		1
END				

EPSON

DFX8000

Page 6

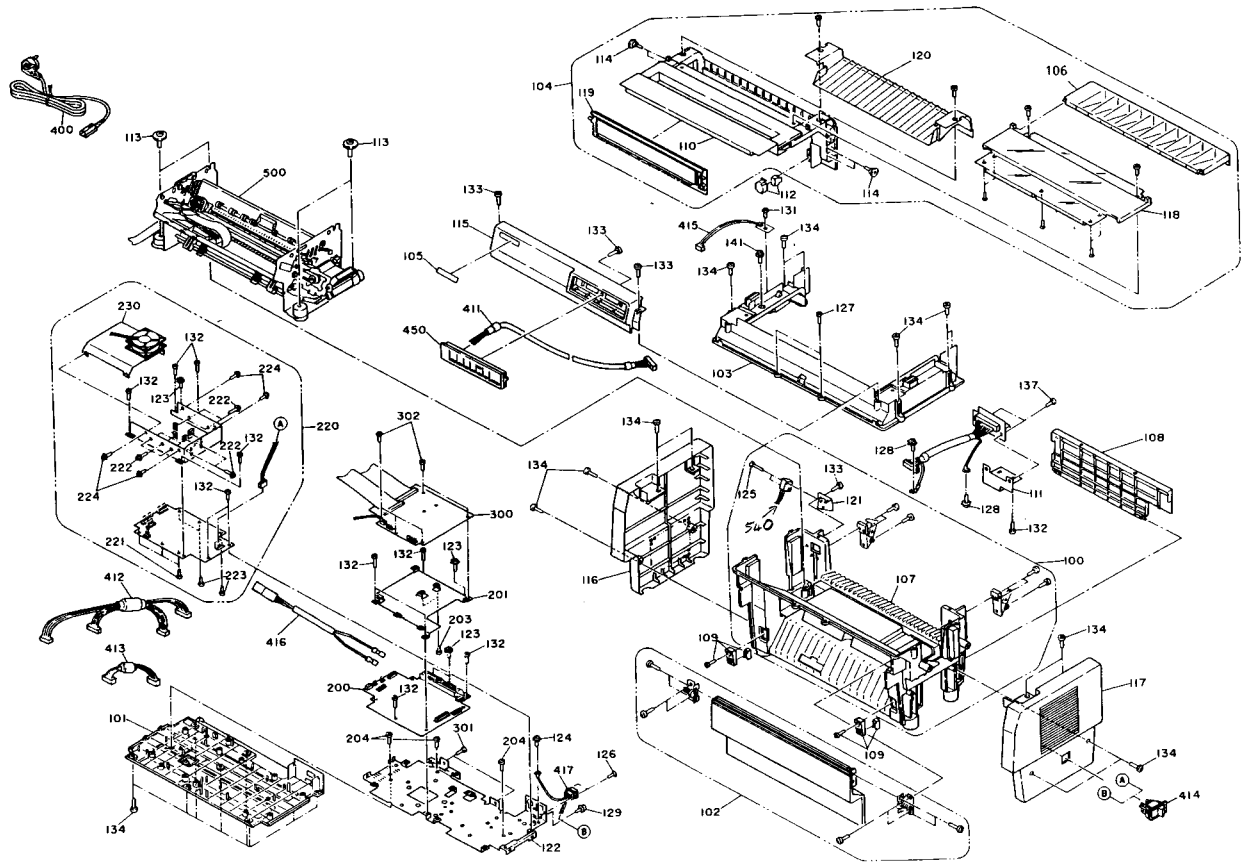

EPSON

DFX8000

Page 7

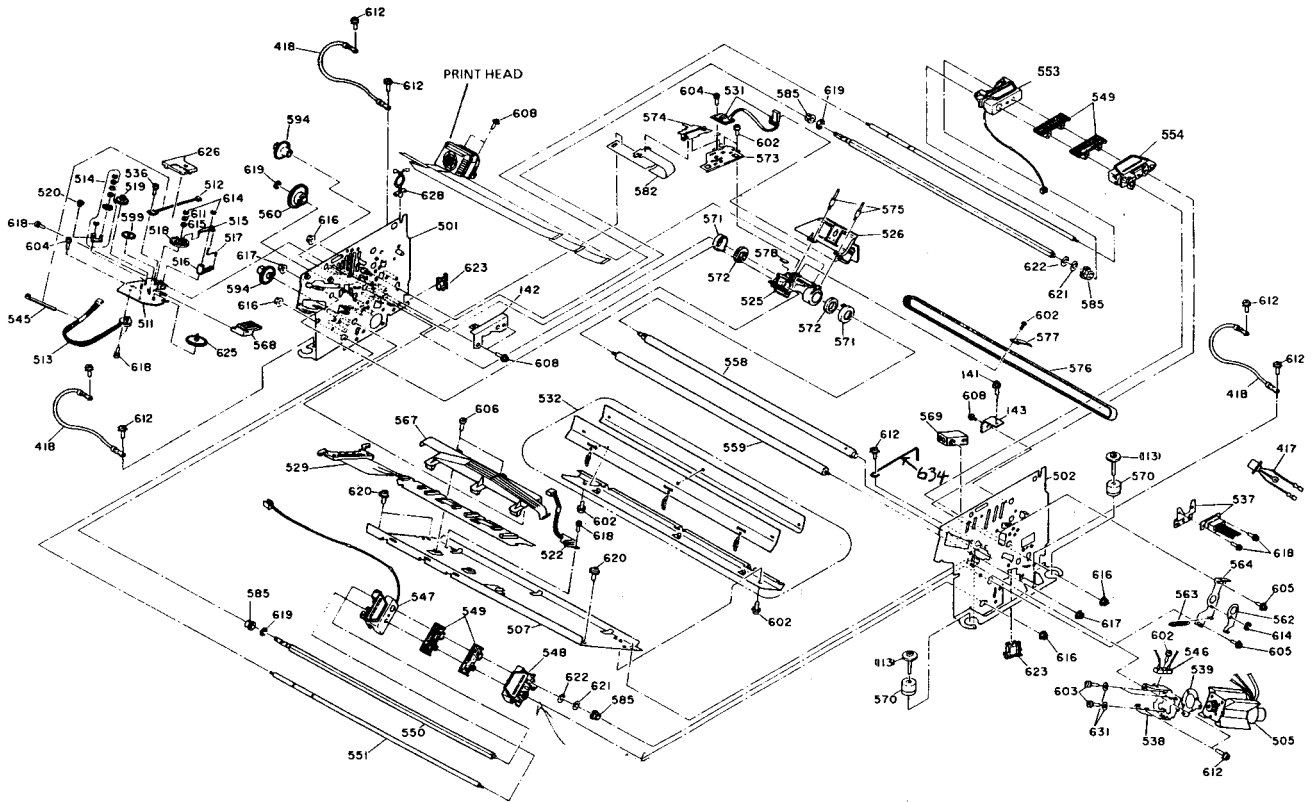

DFX 8000 FIG.2

EPSON

DFX8000

Page 8

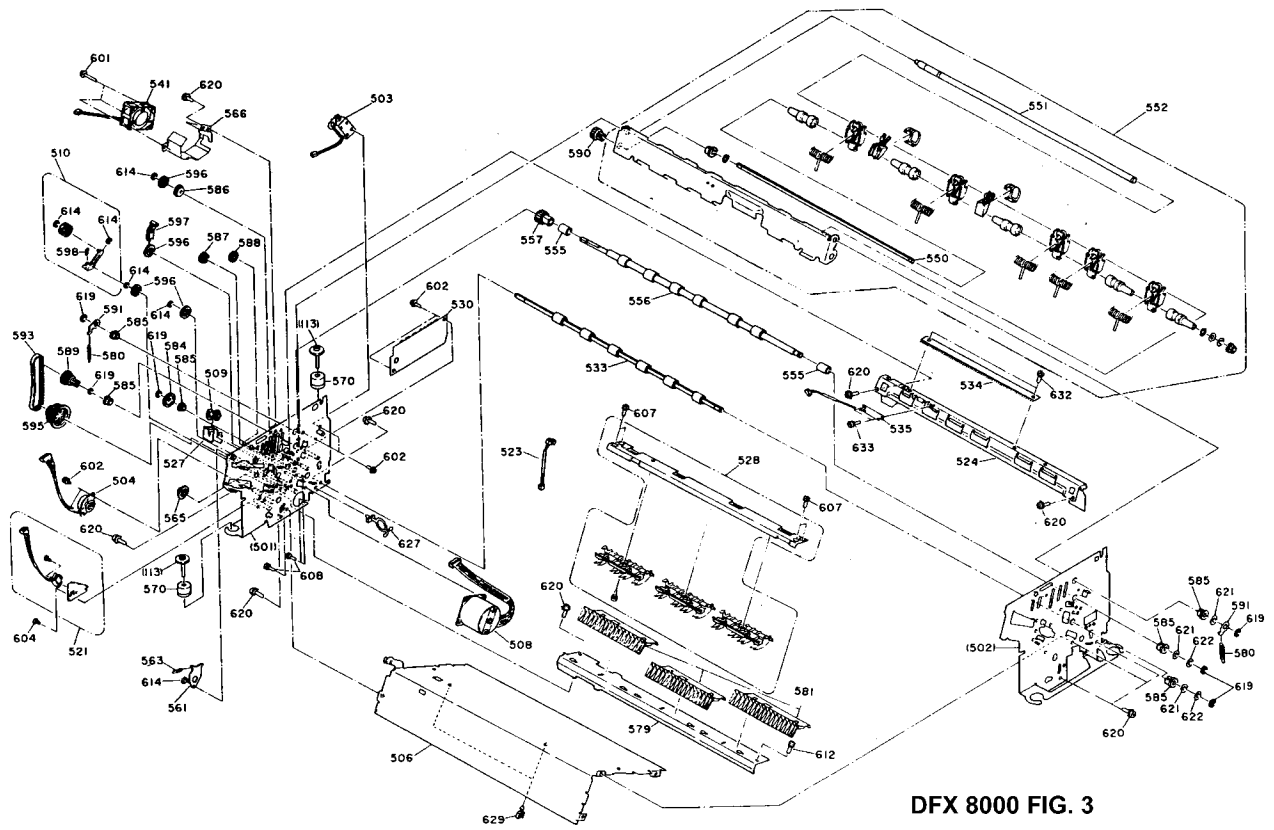

DFX 8000 FIG. 3

EPSON

DFX8000

Page 10