

7. Parts catalog

How to use this parts catalog

The following legend is used in the parts catalog:

Asm-Index	Part number	Units/mach	Description
-----------	-------------	------------	-------------

- **Asm-index:** identifies the assembly and the item in the diagram. For example, 3-1 indicates assembly 3 and the item number 1.
- **Part number:** identifies the unique number that identifies this FRU.
- **Units/mach:** refers to the number of units actually used in the machine or product.
- **NS:** (Not shown) in the Asm-Index column indicates that the part is procurable, but is not pictured in the illustration.
- **PP:** (Parts Packet) in the parts description column indicates that the part is contained in a parts packet.

Assembly 1: Covers 1

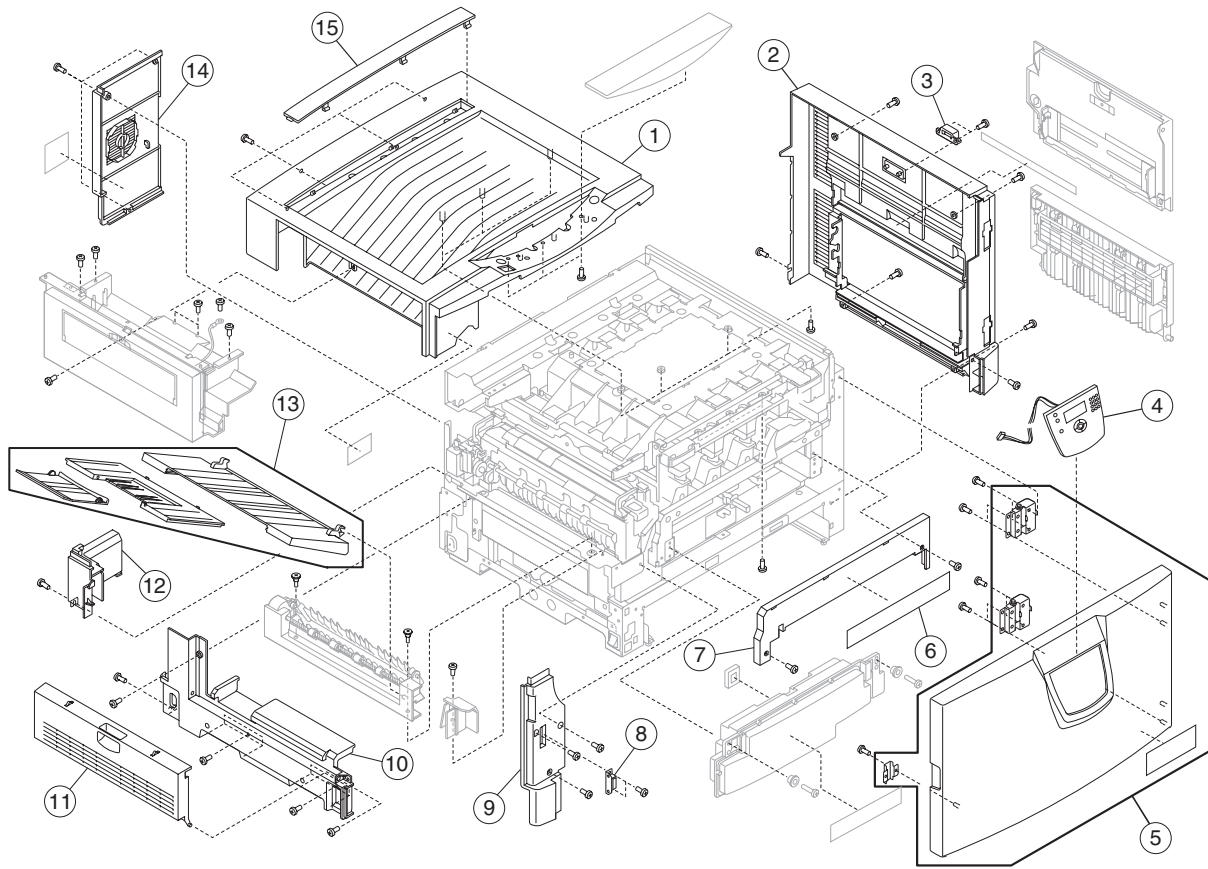

Assembly 1: Covers 1

Index	P/N	Units	Description
1-1	40X1131	1	Cover, top
1-2	40X1124	1	Cover assembly, right side
1-3	40X1139	1	Magnet, right side latch
1-4	40X1259	1	Operator panel
1-5	40X1123	1	Cover assembly, front
1-6	56P9545	1	Label, operator panel
1-7	40X1132	1	Cover, waste toner bottle
1-8	40X1140	1	Magnet, front cover latch
1-9	40X1129	1	Cover, left front
1-10	40X1126	1	Cover, left side
1-11	40X1127	1	Cover, paper feed
1-12	40X1125	1	Cover, solenoid
1-13	40X1122	1	Tray assembly, exit
1-14	40X1128	1	Cover, rear
1-15	40X1130	1	Cover, adjustment
NS	40X1516		Label, MPT
NS	40X1262		Parts packet

Assembly 2: Covers 2

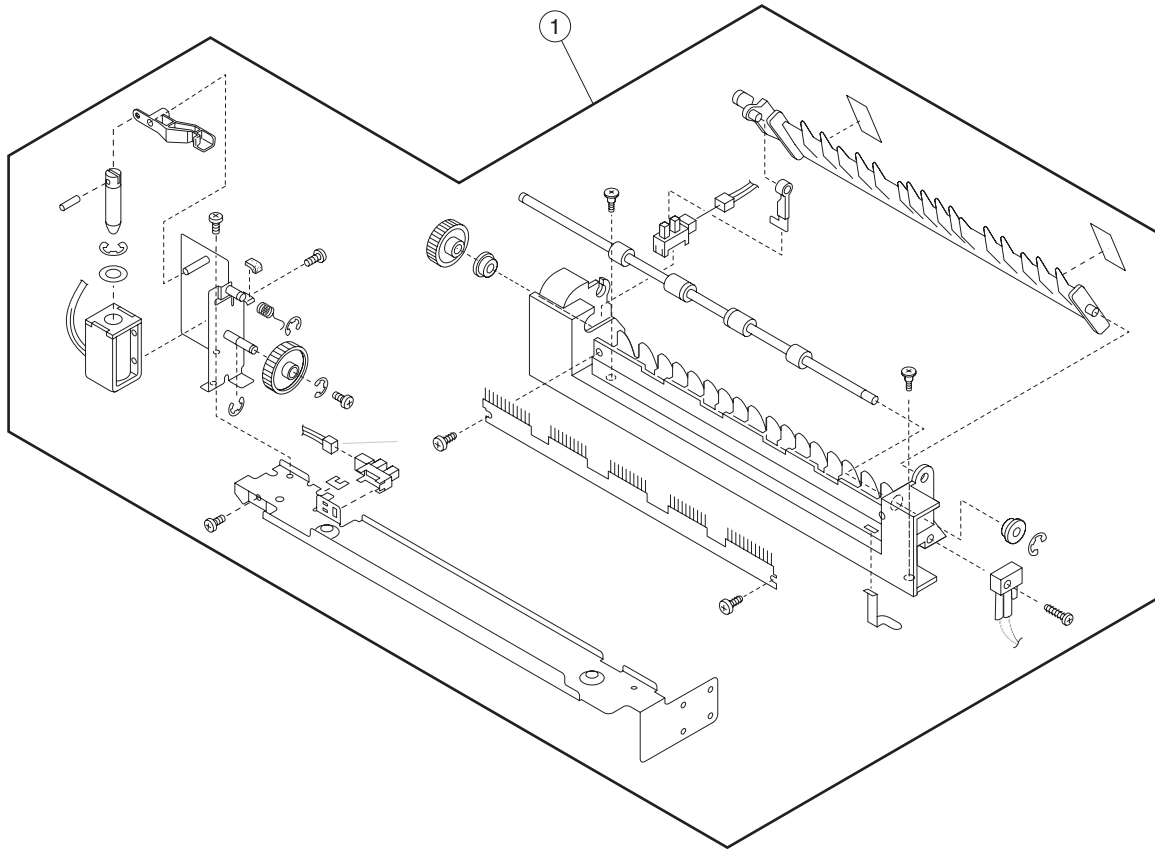

Index	P/N	Units	Description
2 —1	40X1026	1	Exit assembly, face up

Assembly 3: Covers 3

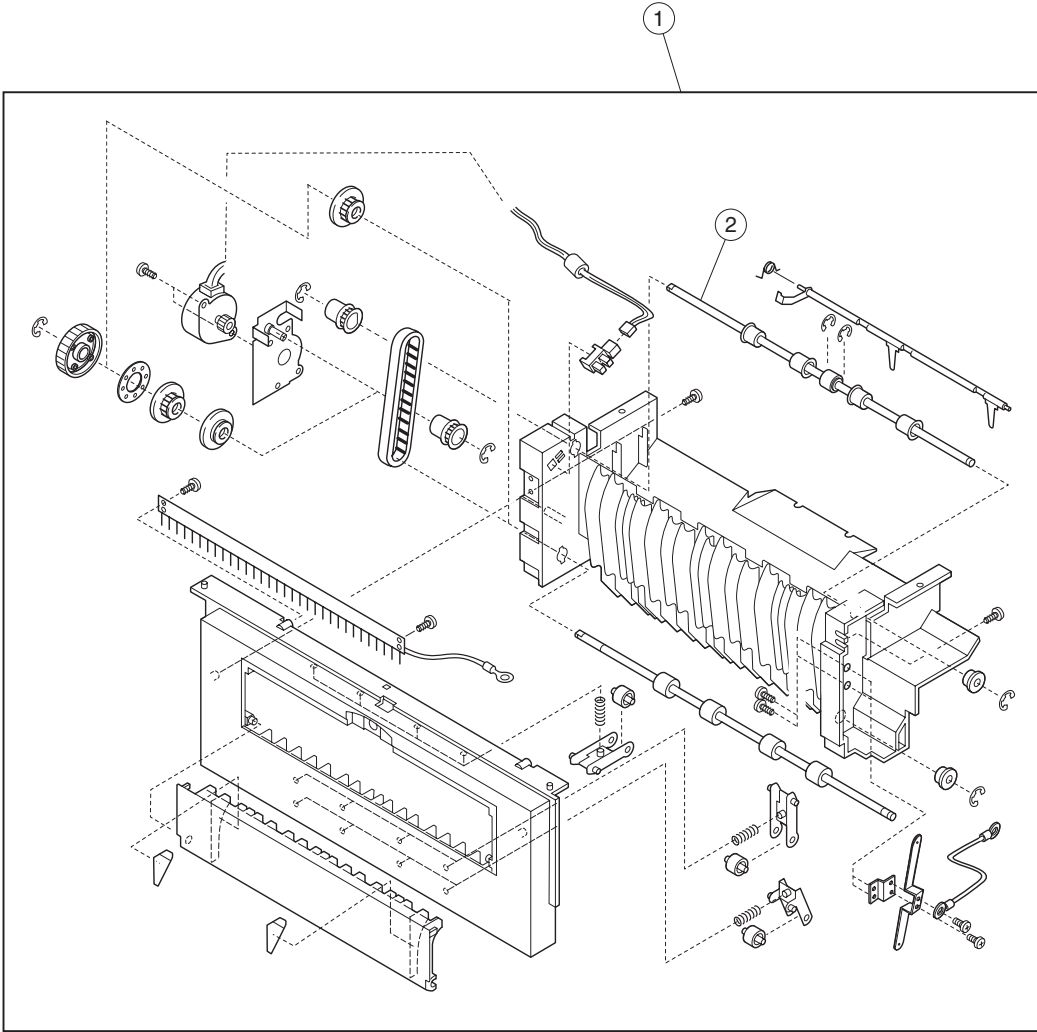

Index	P/N	Units	Description
3 —1	40X1027	1	Guide assembly, face-down
3 —2	40X1064	1	Exit roller, face-down

Assembly 4: Covers 4

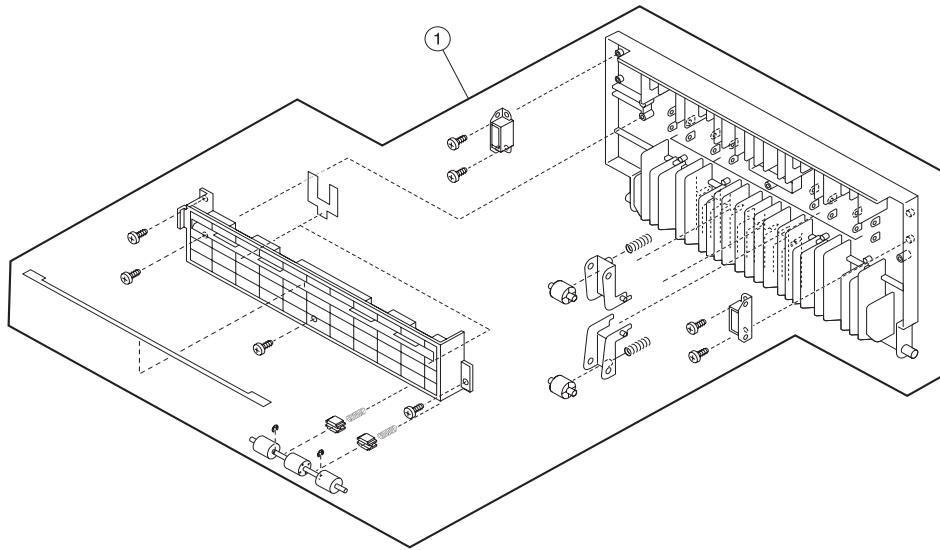

Index	P/N	Units	Description
4 —1	40X1242	1	Guide assembly, turn

Assembly 5: Covers 5

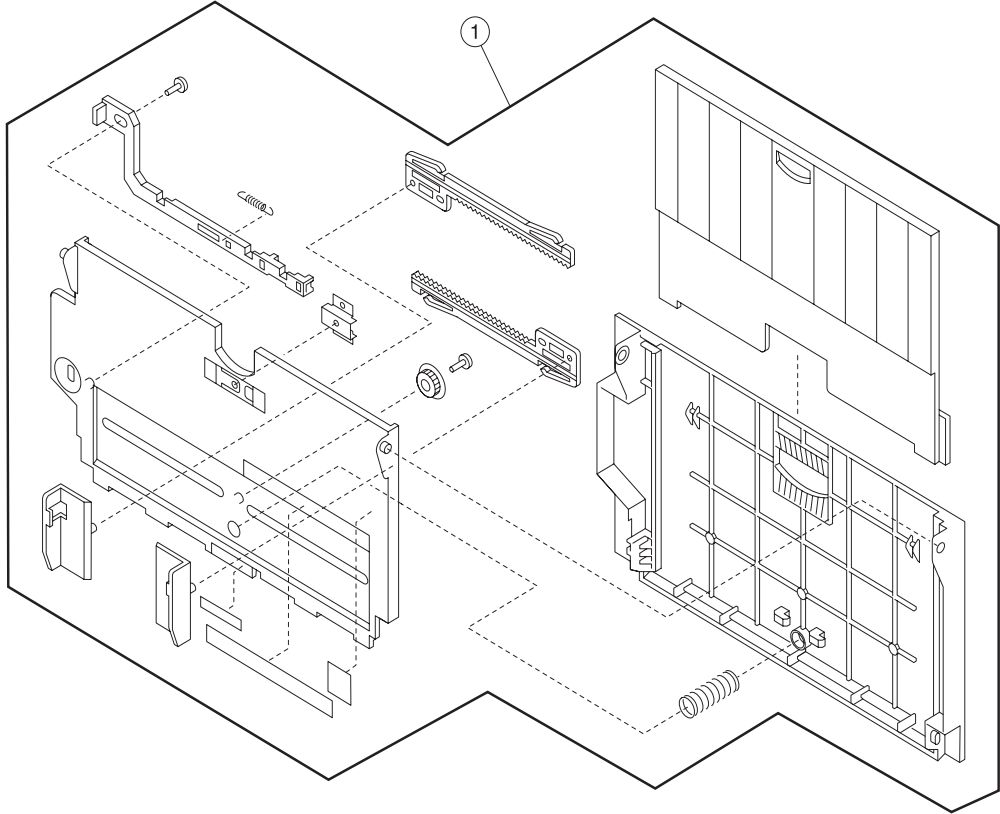

Index	P/N	Units	Description
5 —1	40X1135	1	Feeder assembly, multipurpose

Assembly 6: Upper unit

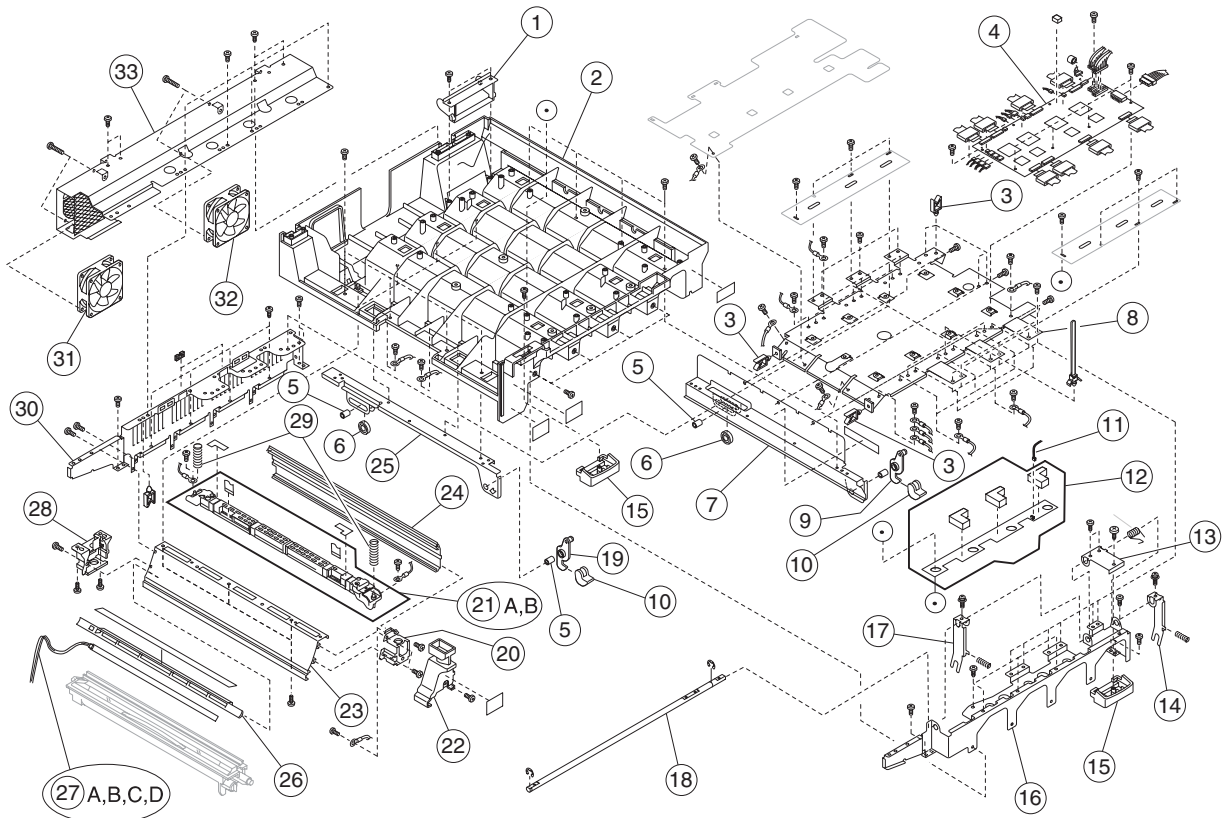

Assembly 6: Upper unit

Index	P/N	Units	Description
6-1	56P9632	1	Shroud, cable
6-2	56P9591	1	Frame, upper
6-3	56P9638	4	Holder, cable
6-4	40X1220	1	Board, printhead controller
6-5	56P9628	2	Pivot, color link
6-6	56P9627	2	Bearing, roller
6-7	56P9624	1	Link, frame
6-8	40X1149	1	Frame, printhead controller
6-9	56P9625	1	Hook, right link
6-10	56P9626	2	Cover, hook
6-11	40X1118	1	Cable, RFID
6-12	40X1117	1	Assembly, RFID
6-13	40X1145	1	Hook, middle
6-14	40X1147	1	Hook, right
6-15	40X1257	1	Handle, up opening
6-16	40X1143	1	Bracket, front upper
6-17	40X1146	1	Hook, left
6-18	40X1144	1	Rod, interlocking
6-19	56P9630	1	Hook, left link
6-20	40X1142	4	Holder, front hsp
6-21A	40X1133	1	Assembly, LED printhead (K)
6-21B	40X1134	3	Assembly, LED printhead (C)
6-22	56P9611	4	Holder, front printhead
6-23	56P9592	4	Rail, left side
6-24	56P9610	4	Rail, right side
6-25	56P9629	1	Link, frame
6-26	56P9594	4	Cover, eraser
6-27A	40X1028	1	Lamp, M erase
6-27B	40X1029	1	Lamp, C erase
6-27C	40X1030	1	Lamp, Y erase
6-27D	40X1031	1	Lamp, K erase
6-28	56P9593	4	Holder, rear printhead
6-29	56P9609	8	Spring, printhead
6-30	40X1148	1	Bracket, rear upper
6-31	40X1032	1	Fan, upper right
6-32	40X1033	1	Fan, upper left
6-33	56P9621	1	Bracket, fan holder
NS	56P9993	4	Shield, light (used on p/n 56P9594)
NS	40X1263		Parts packet

Assembly 7: Paper feed

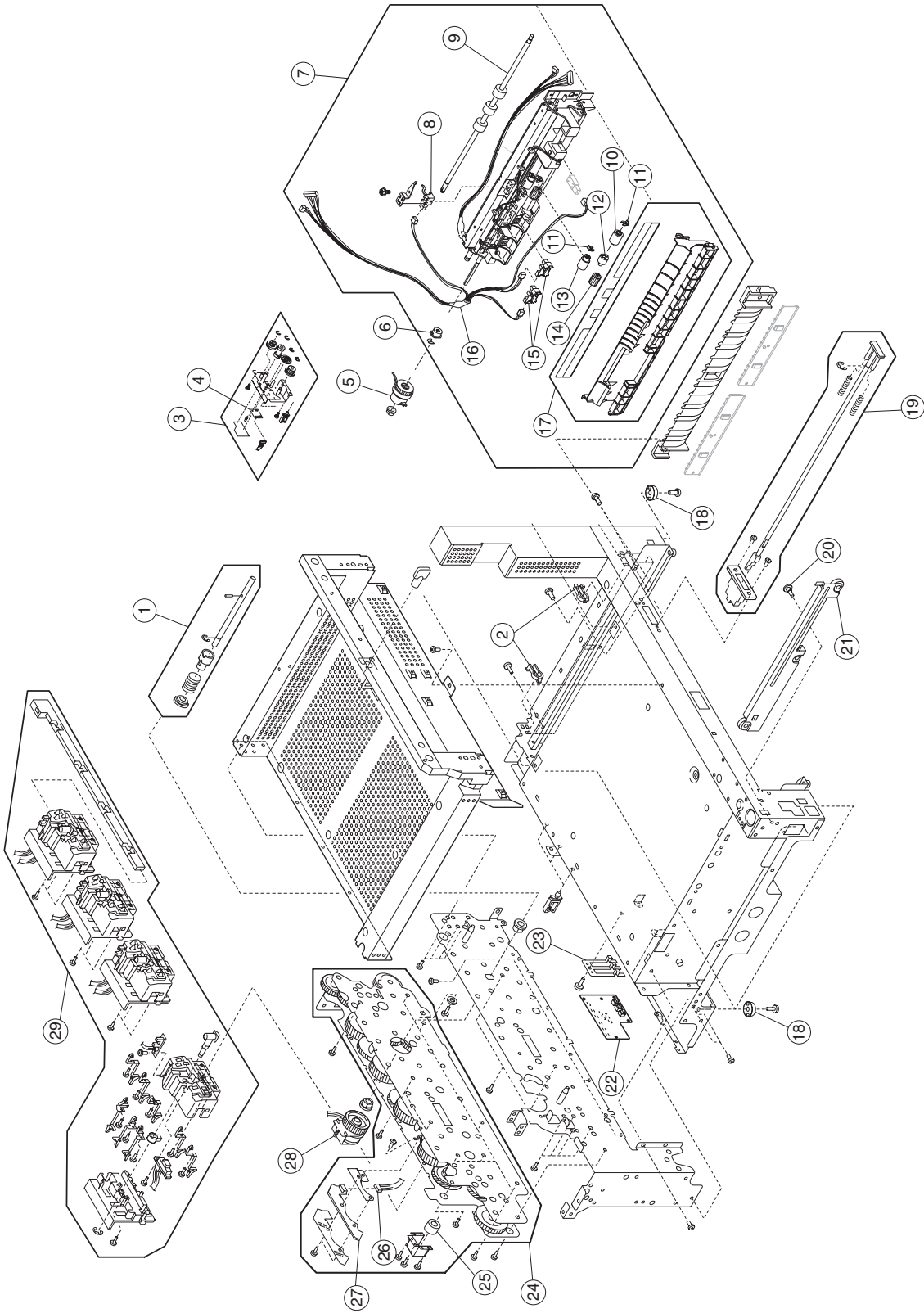

Assembly 7: Paper feed

Index	P/N	Units	Description
7—1	40X1119	1	Shaft, changing
7—2	40X1103	2	Bushing, turn guide
7—3	40X1112	1	Assembly, drive link
7—4	40X1247	1	Sensor, humidity (not included in 7-3)
7—5	40X1082	1	Clutch, paper feed
7—6	40X1081	1	Clutch, roller 6 x 10 x 14
7—7	40X1075	1	Assembly, paper-feed base
7—8	40X1107	1	Sensor, relay
7—9	40X1108	1	Roller, relay
7—10	40X1079	1	Roller, separator
7—11	40X1106	1	Clip, paper-feed shaft
7—12	40X1080	1	Clutch, friction (torque limiter)
7—13	40X1078	1	Roller, paper feed
7—14	40X1077	1	Roller, pickup
7—15	40X1173	2	Interrupt, photo
7—16	40X1098	1	Cable asm, paper-feed type 1
7—17	40X1076	1	Plate, guide rocking
7—18	56P9503	4	Foot, rubber
7—19	56P9641	1	Actuator, front cover open switch
7—20	56P9524	1	Screw, slide rail
7—21	40X1034	1	Rail, base left side
7—22	40X1083	1	Board, CK2 daughter board/sensor
7—23	56P9521	1	Lever, size sense
7—24	40X1035	1	Unit, drive 120V
7—24	40X1036	1	Unit, drive 230V
7—25	40X1150	1	Clutch, drive unit
7—26	56P9644	1	Cable asm, drive unit sensor
7—27	56P9645	1	Sensor, drive unit
7—28	40X1037	1	Clutch, belt up/down
7—29	40X1038	1	Frame, sub
NS	40X1264	-	Parts packet (See “Parts packets” on page 7-58 for contents)

Assembly 8: Base 2

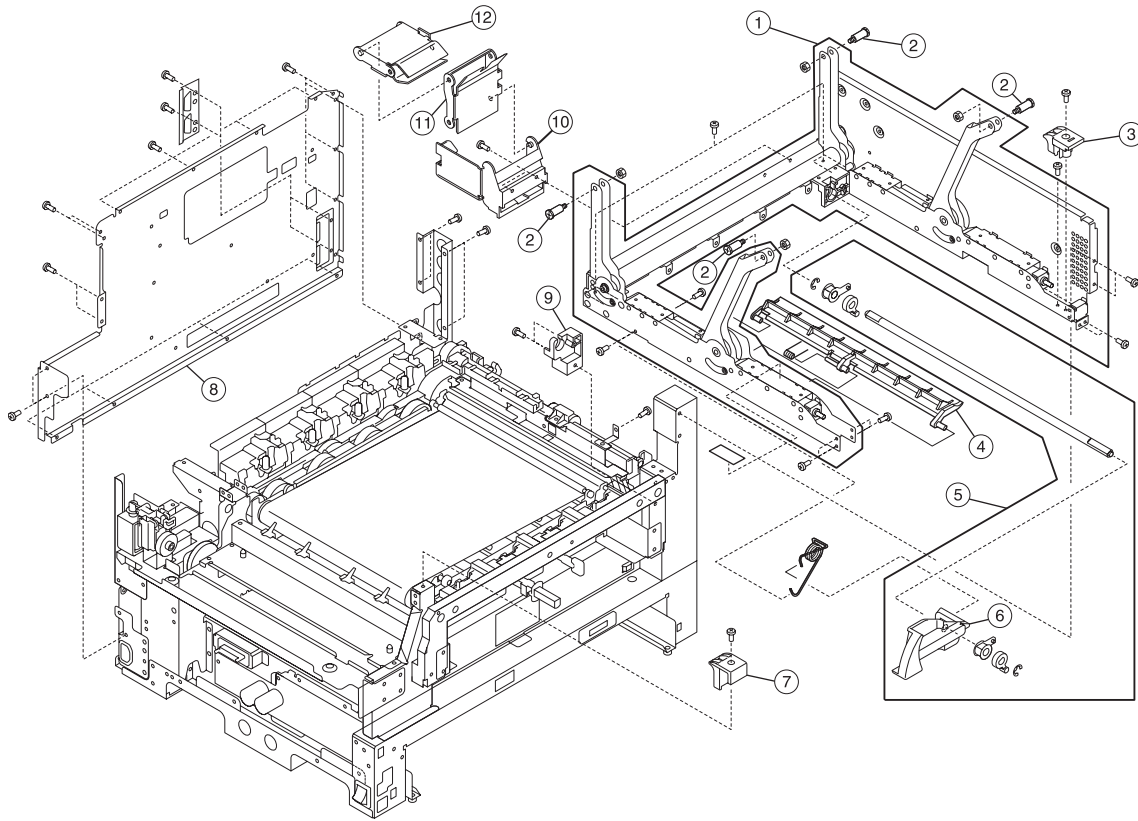

Assembly 8: Base 2

Index	P/N	Units	Description
8 —1	40X1207	1	Support assembly, upper unit
2	56P9667	4	Pin, upper unit support
3	40X2776	1	Stop, right
4	40X2779	1	Cover, black photodeveloper
5	40X1208	1	Handle assembly, lock
6	56P9669	1	Handle, lock
7	40X2778	1	Stop, left
8	40X1151	1	Cover, electronic
9	40X2777	1	Guide, lock
10	56P9670	1	Shroud, cable
11	56P9672	1	Guide, cable
12	56P9671	1	Guide, cable
NS	40X1265	1	Parts packet

Assembly 9: Base 3

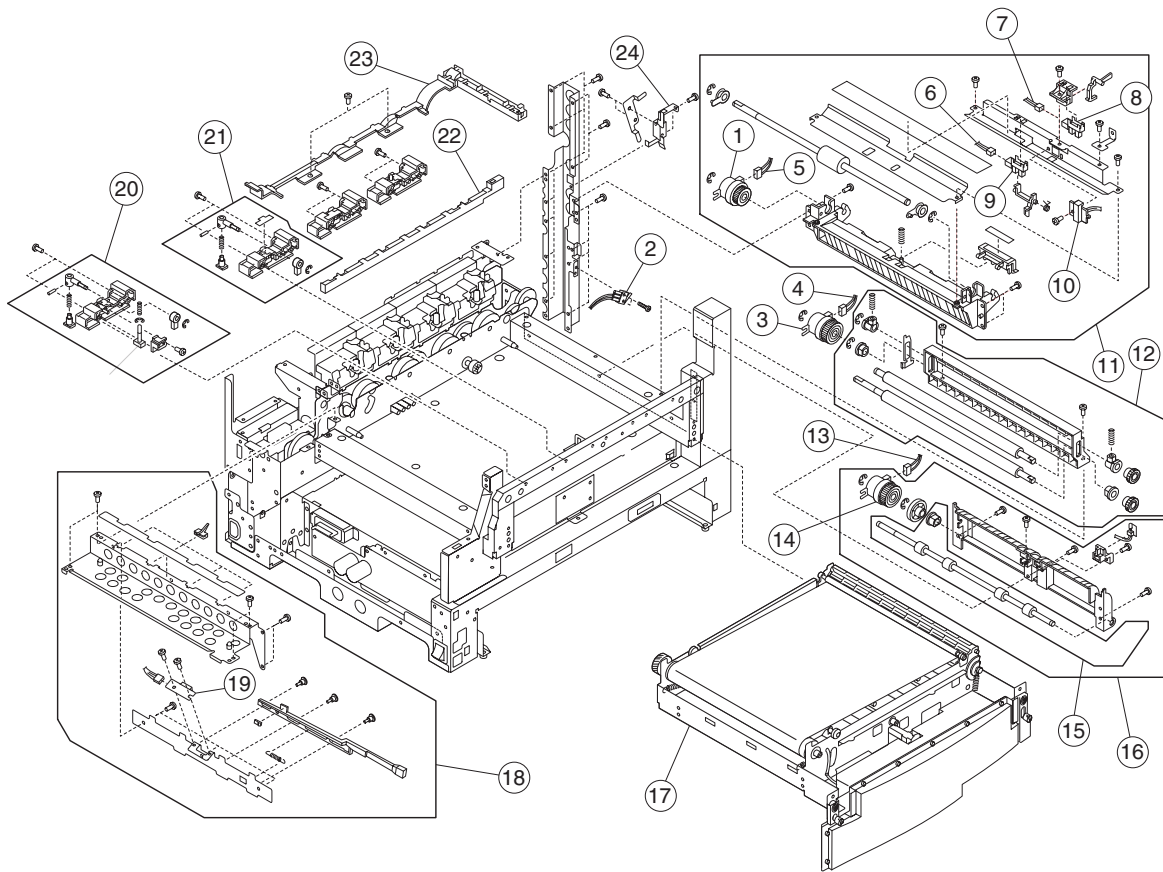

Assembly 9: Base 3

Index	P/N	Units	Description
9—1	40X1067	1	Clutch, MPF
9—2	40X1085	1	Switch, turn guide
9—3	40X1040	1	Clutch, registration
9—4	40X1113	1	Cable, registration clutch
9—5	40X1116	1	Cable, MPF clutch
9—6	40X1115	1	Cable, registration sensor
9—7	40X1115	1	Cable, registration sensor
9—8	40X1137	1	Photo interruptor
9—9	40X1136	1	Photo interruptor
9—10	40X1211	1	Sensor, upper OHP
9—11	40X1039	1	Frame assembly, MPF
9—12	40X1154	1	Frame assembly, registration
9—13	40X1114	1	Cable, carrying clutch
9—14	40X1040	1	Clutch, registration (used on carrying frame)
9—15	56P9683	1	Roller assembly, carrying
9—16	40X1025	1	Frame assembly, carrying
9—17	40X1041	1	Unit, transfer belt
9—18	40X1209	1	Guide assembly, fuser entry
9—19	40X1152	1	Sensor, density
9—20	40X1155	2	Frame assembly, F1 sub
9—21	56P9685	2	Frame assembly, F2 sub
9—22	56P9686	1	Rod, lock
9—23	56P9687	1	Cover, gear
9—24	40X1156	1	Stopper, clutch
NS	56P9697	1	Bushing
NS	40X1266		Parts packet

Assembly 10: Electrical A

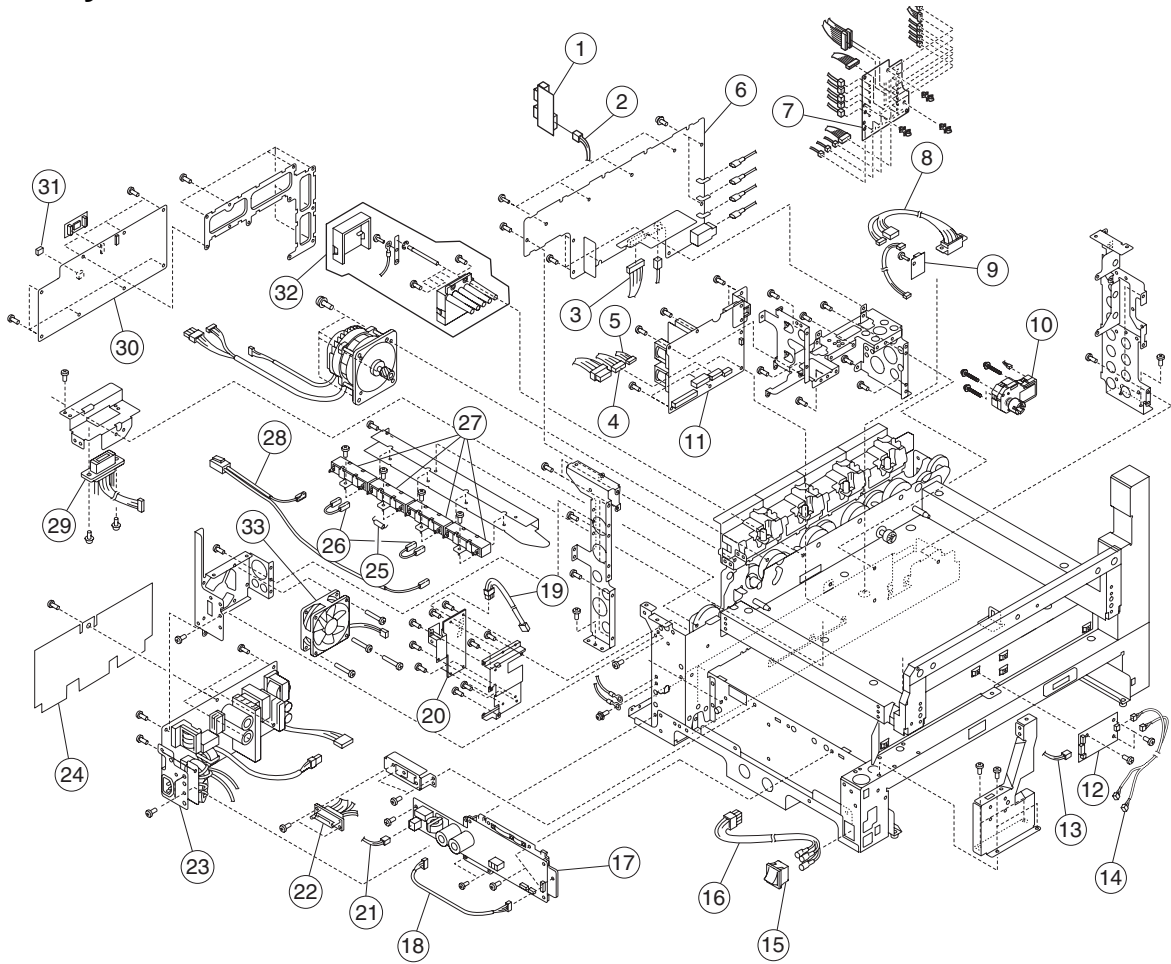

Assembly 10: Electrical A

Index	P/N	Units	Description
10 —1	40X1101	1	Asm, HCF/FIN D-Sub
10 —2	40X1102	1	Cable asm, finisher
10 —3	56P9715	1	Cable asm, HVU
10 —4	56P9727	1	Cable asm, printer controller power 2
10 —5	40X1053	1	Cable asm, printer controller power 1
10 —6	40X1159	1	Supply, high voltage
10 —7	40X1084	1	Card, CK1 Daughter
10 —8	40X1042	1	Cable asm, feeder
10 —9	40X1247	1	Sensor, humidity
10 —10	40X1097	1	Motor, paper tray lift
10 —11	40X1162	1	Supply, 120V power 2
10 —11	40X1163	1	Supply, 230V power 2
10 —12	40X1043	1	Board, sensor
10 —13	40X1044	1	Cable asm, sensor board
10 —14	40X1120	1	Cable, belt relay
10 —15	40X1158	1	Switch, power
10 —16	40X1157	1	Cable, power switch
10 —17	40X1045	1	Board, 120V motor driver
10 —17	40X1046	1	Board, 230V motor driver
10 —18	40X1055	1	Cable asm, MIF
10 —19	40X1205	1	Cable asm, conditioning printer controller
10 —20	40X1164	1	Card, conditioning (230V only)
10 —21	56P9747	1	Cable, motor driver power
10 —22	40X1048	1	Cable asm, duplex connector
10 —23	40X1160	1	Supply, 120V power 1
10 —23	40X1161	1	Supply, 230V power 1
10 —24	56P9737	1	Sheet, insulation
10 —25	40X1517	1	Fuse, thermal (230V only)
10 —26	56P9738	1	Cable, conditioning joint (230V only)
10 —27	56P9741	1	Resistor, conditioning (230V only)
10 —28	56P9740	1	Cable, conditioning resistor (230V only)
10 —29	40X1049	1	Cable, fuser drawer
10 —29	40X1050	1	Cable, fuser drawer (230V only)
10 —30	40X1051	1	Board, printer controller
10 —31	56P9729	1	EEPROM, printer controller
10 —32	40X1052	1	Belt, power supply
10 —33	40X1047	1	Fan, power supply
NS	40X0269		Cord (8ft right angle) , US, Canada, ET AL
NS	40X0270		Cord (8ft 15A straight), Japan
NS	40X0286		Cord (6ft straight), England, France, Germany, Spain, Belgium
NS	40X0272		Cord (8ft right angle), Argentina, Paraguay, Uruguay
NS	40X0273		Cord (8ft straight), Italy
NS	40X0274		Cord (6ft straight), Switzerland
NS	40X0271		Cord (8ft straight), UK

Assembly 10 (continued): Electrical A

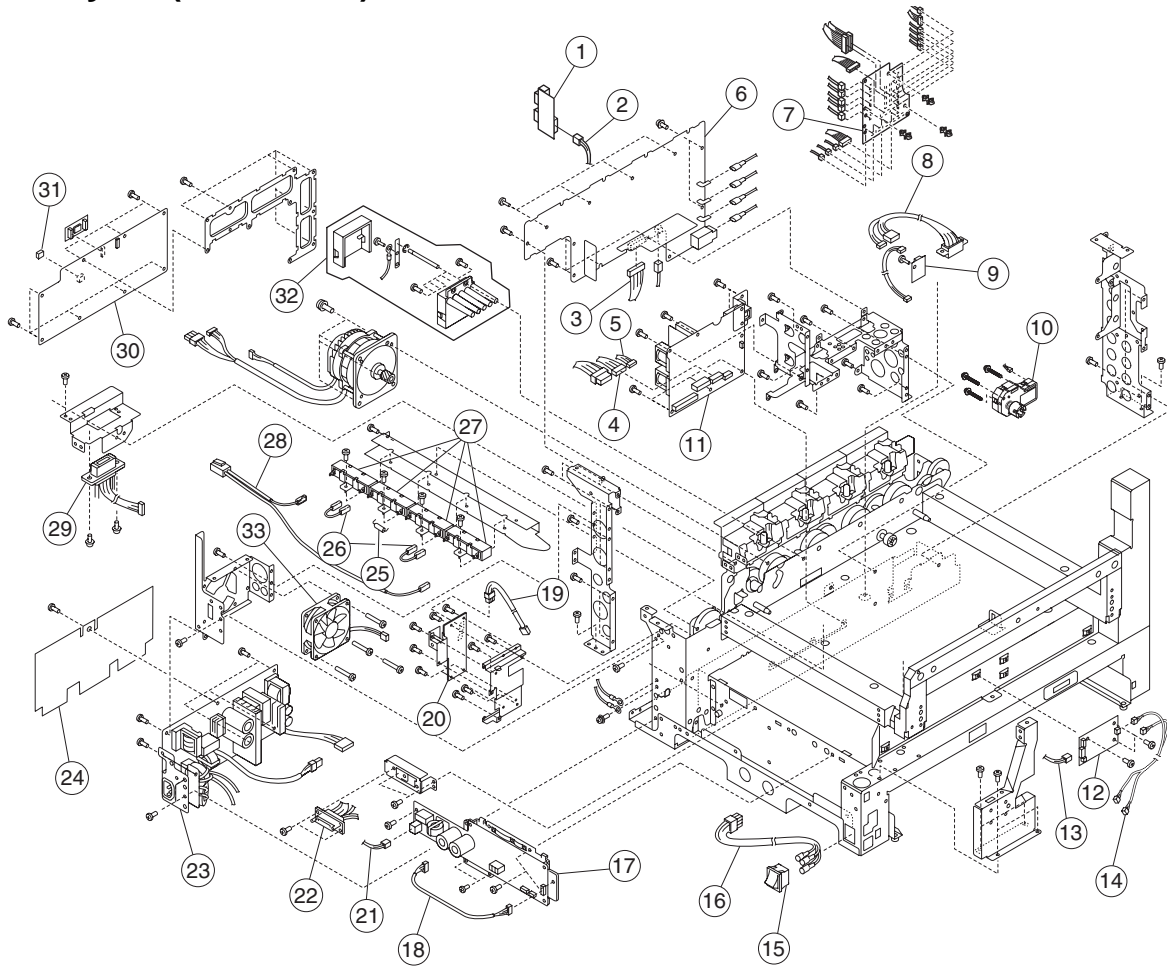

Assembly 10 (continued): Electrical A

Index	P/N	Units	Description
NS	40X0275		Cord (6ft straight), Israel
NS	40X0276		Cord (6ft straight), South Africa
NS	40X0277		Cord (6ft high amp straight), Brazil (HV, LV)
NS	40X0278		Cord (HV 6ft straight), Austria, Russia
NS	40X0279		Cord (6ft straight), Denmark, Finland, Norway, Sweden
NS	40X0280		Cord (10A 3 cond. 6ft straight) , Korea
NS	40X0281		Cord (13A 3 cond. 6ft straight), Taiwan
NS	40X0282		Cord (1.77M straight), People's Republic of China
NS	40X0296		Cord (6ft straight), Australia
NS	40X1104		Interruptor, photo (paper low sensor)
NS	40X1267		Parts packet
NS	56P9964		Transformer (Japan Only)

Assembly 11: Electrical B

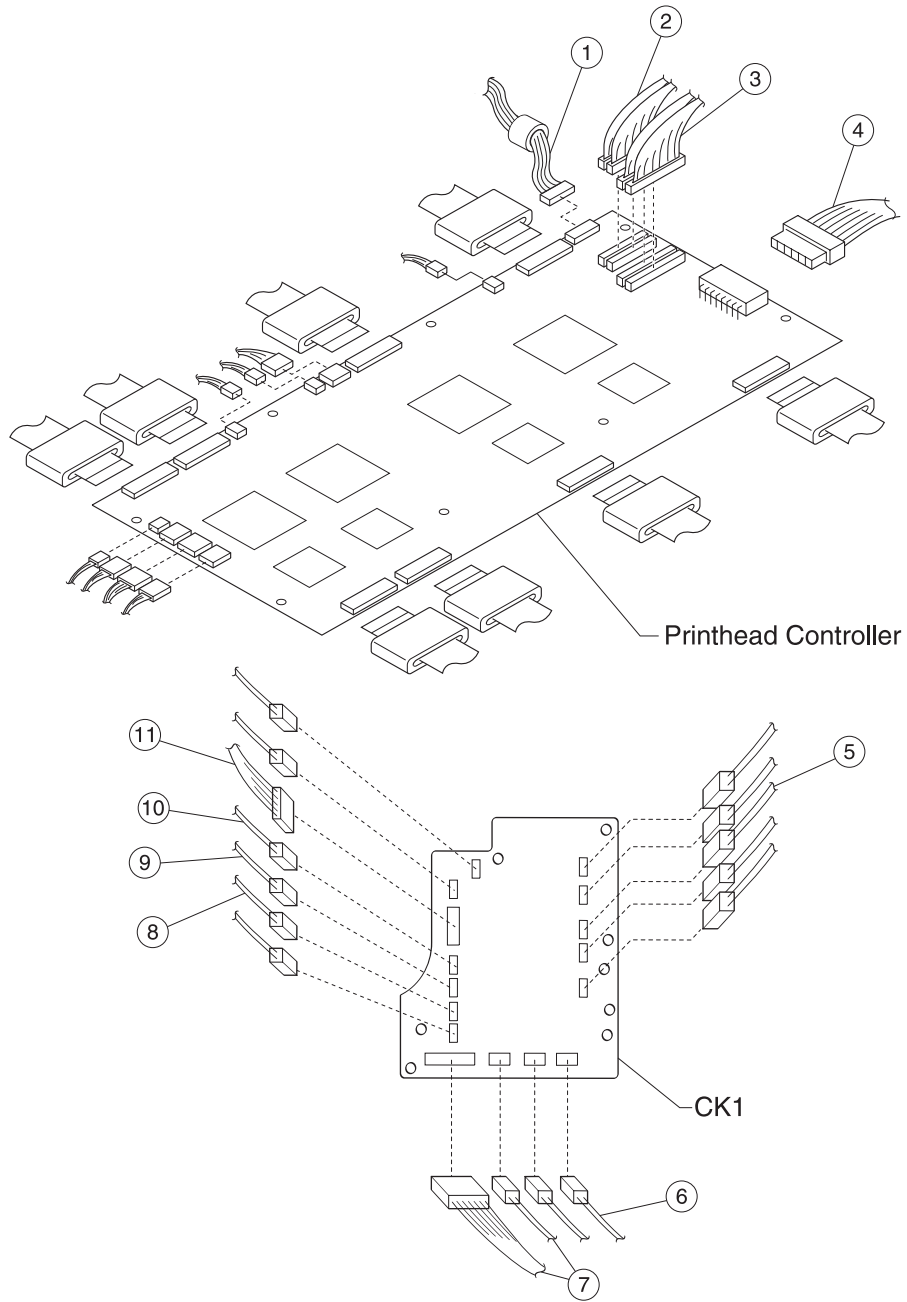

Assembly 11: Electrical B

Index	P/N	Units	Description
11-4	40X1068	1	Cable assembly, 8 pin PH controller
2	40X1074	1	Cable assembly, 30 pin RIP harness
3	40X1073	1	Cable assembly, 36 pin RIP harness
4	56P9720	1	Cable assembly, printhead controller power
5	40X1099	1	Cable assembly, paper tray lift motor
6	40X1100	1	Cable assembly, cassette bottom sensor
7	40X1098	1	Cable assembly, paper feed type 1
8	40X1114	1	Cable assembly, carrying clutch
9	40X1116	1	Cable assembly, MPF clutch
10	40X1113	1	Cable assembly, registration clutch
11	40X1115	1	Cable assembly, registration sensor
NS	40X1267	1	Parts packet

Assembly 12: RIP board

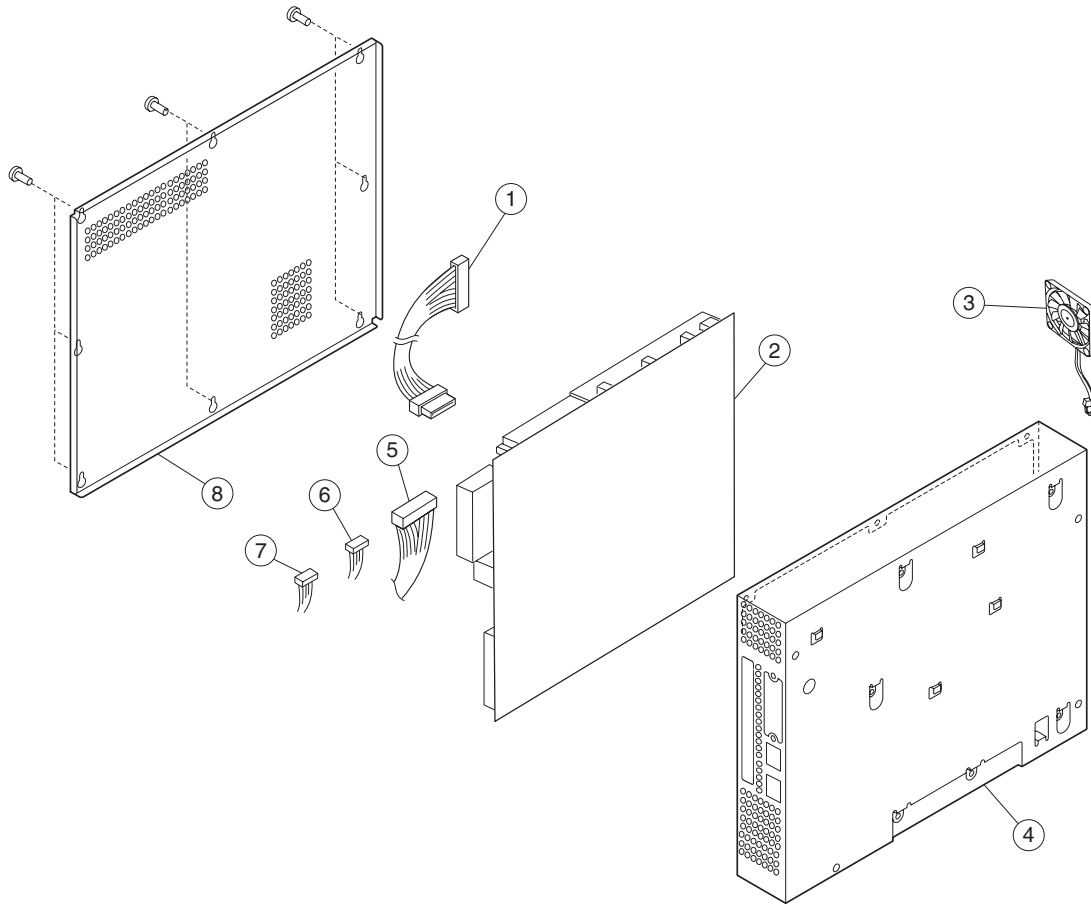

Index	P/N	Units	Description
12-4	56P9749	1	Cable assembly, power RIP
2	40X2644	1	Card assembly, RIP
3	40X1520	1	Fan, RIP box
4	40X1165	1	Box, RIP
5	40X1054	1	Cable assembly, 26 pin RIP printer controller
6	40X1255	1	Cable, USB
7	40X1256	1	Cable, operator panel
8	40X1166	1	Cover, RIP box
NS	40X1268	1	Parts packet

Assembly 13: Fuser unit

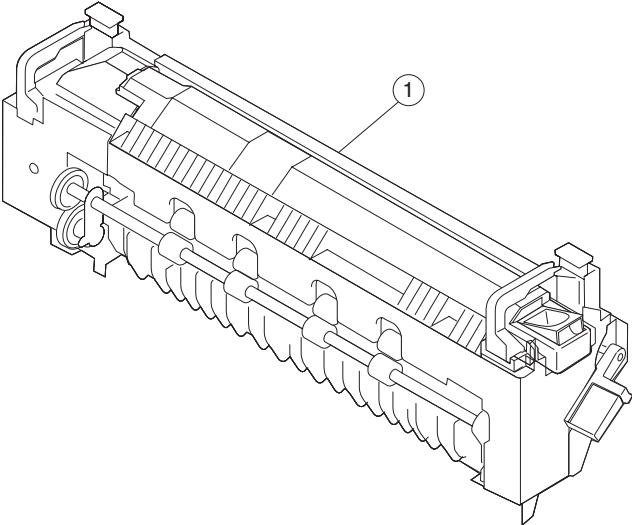

Index	P/N	Units	Description
13-4	40X1056	1	Fuser, 120V
1	40X1057	1	Fuser, 230V

Assembly 14: Cassette

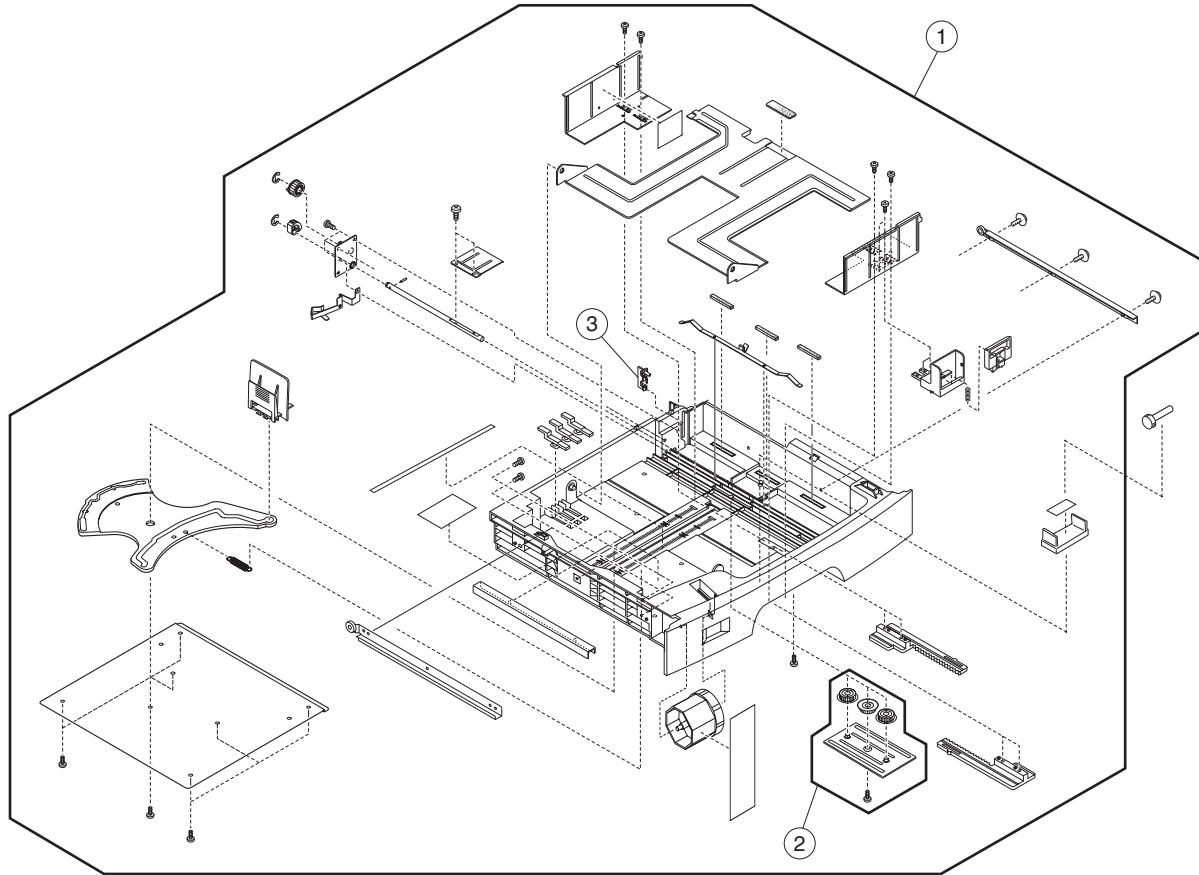

Assembly 14: Cassette

Index	P/N	Units	Description
14-4	40X1058	1	Cassette, paper feed
2	40X1501	1	Kit, rack guard holder
3	40X1105	1	Flag, bottom sense

Assembly 15: Expansion feeder 1

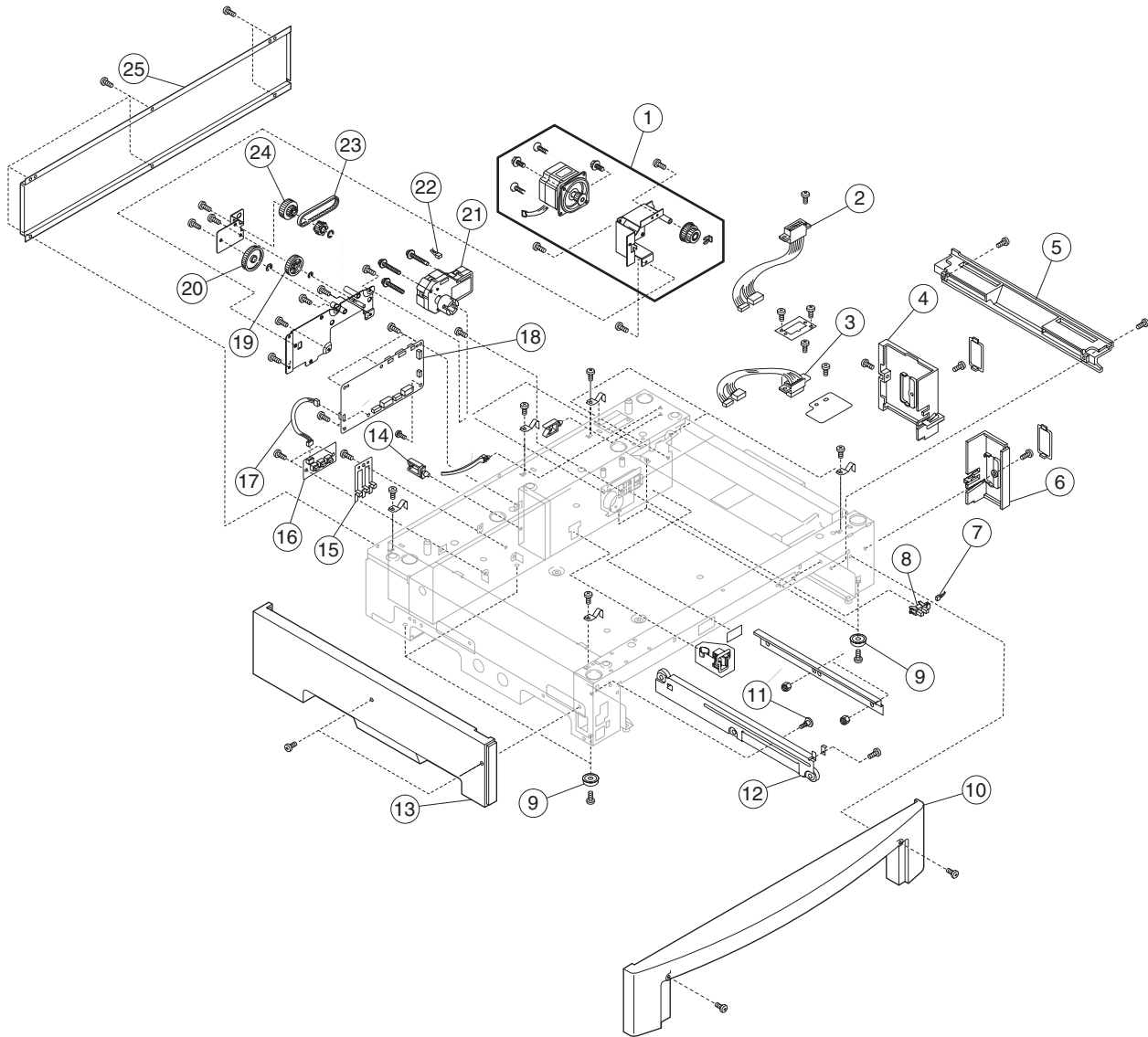

Assembly 15: Expansion feeder 1

Index	P/N	Units	Description
	56P4024	—	Assembly, expansion feeder
15-4	40X1090	1	Motor asm, stepping
2	56P9777	1	Cable asm, upper optional drawer
3	56P9778	1	Cable asm, lower optional drawer
4	40X1204	1	Cover, right side C
5	40X1203	1	Cover, right side B
6	40X1202	1	Cover, right side A
7	40X1091	1	Cable asm, expansion paper level
8	40X1173	1	Interrupt, photo
9	56P9503	4	Foot, rubber
10	40X1200	1	Cover, front feed
11	56P9524	1	Screw, slide rail
12	40X1034	1	Rail, base left side
13	40X1201	1	Cover, left side
14	11G0199	2	Guide, wire
15	56P9521	1	Lever, size sense
16	40X3482	1	Card, size sense
17	56P9775	1	Cable asm, size sense
18	40X1059	1	Board, expansion feeder controller
19	40X1096	1	Gear, Z30
20	40X1093	1	Gear, IDS 38
21	40X1097	1	Motor, paper tray lift
22	40X1092	1	Cable asm, expansion lift motor
23	40X1095	1	Belt, timing S3M:177
24	40X1246	1	Gear, Z28:20T
25	40X1167	1	Cover, rear
NS	11G0399	4	Plate, ground
NS	40X1094	1	Pulley, timing 20t
NS	40X1269	1	Parts packet

Assembly 16: Expansion feeder 2

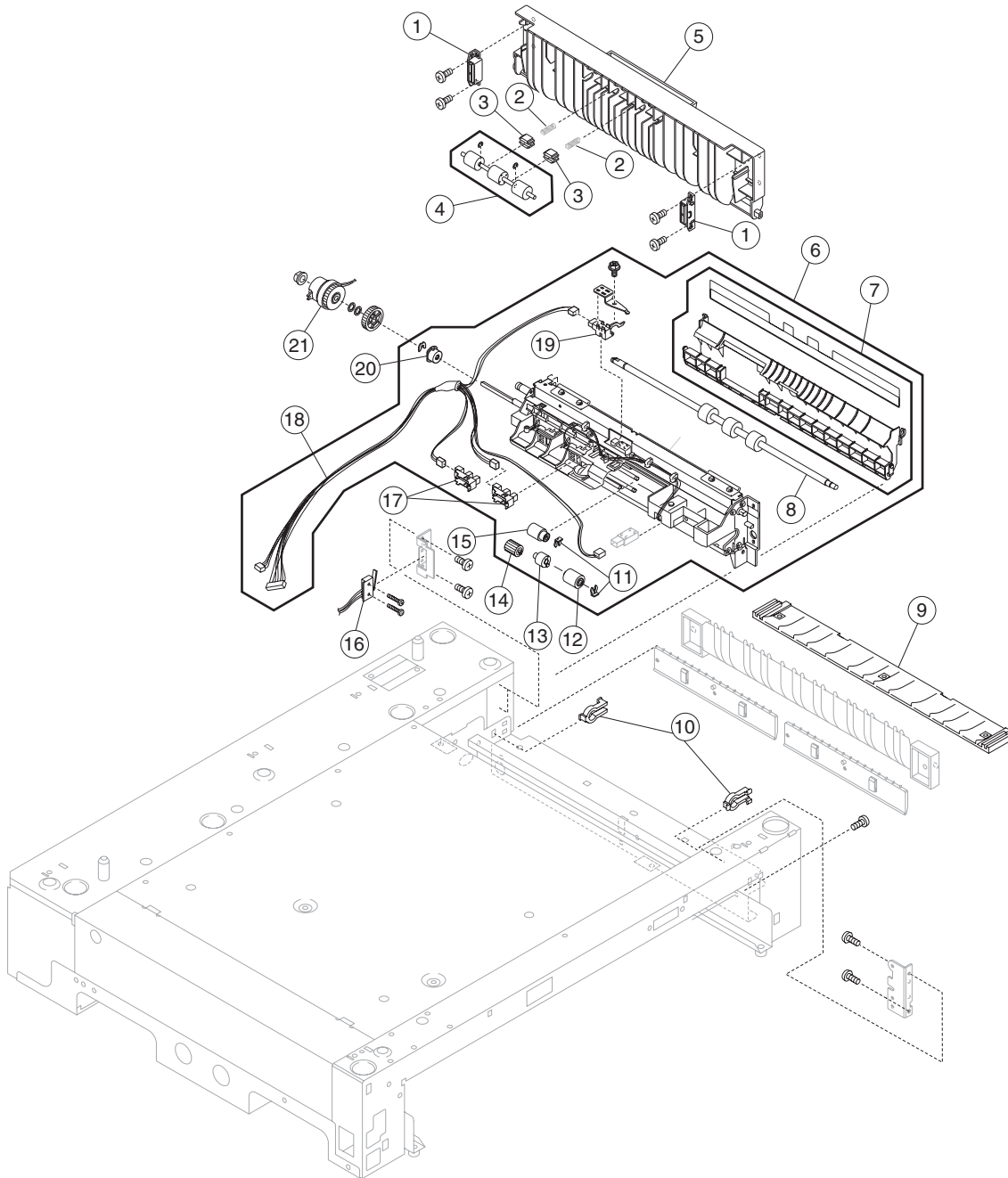

Assembly 16: Expansion feeder 2

Index	P/N	Units	Description
16-4	40X1140	2	Magnet, front cover latch
2	40X1071	2	Spring, paper carry 2
3	40X1070	2	Bushing, pressure
4	40X1072	1	Roller, follow up
5	40X1069	1	Guide assembly, expansion turn guide
6	40X1086	2	Assembly, paper feed expansion
7	40X1076	1	Plate, guide rocking
8	40X1111	1	Roller, relay expansion feed
9	40X3484	1	Guide, HCPF
10	40X1103	1	Bushing, turn guide
11	40X1106	2	Clip, paper feed shaft
12	40X1079	2	Roller, separator
13	40X1080	1	Clutch, friction
14	40X1077	1	Roller, pickup
15	40X1078	1	Roller, paper feed
16	40X1088	1	Assembly, turn guide switch option
17	40X1173	1	Interrupt, photo
18	40X1089	1	Cable asm, paper feed type 2
19	40X1107	1	Sensor, relay
20	40X1081	1	Clutch, roller 6 x 10 x 14
21	40X1087	1	Clutch, paper feed
NS	40X1270		Parts packet

Assembly 17: Duplex unit 1

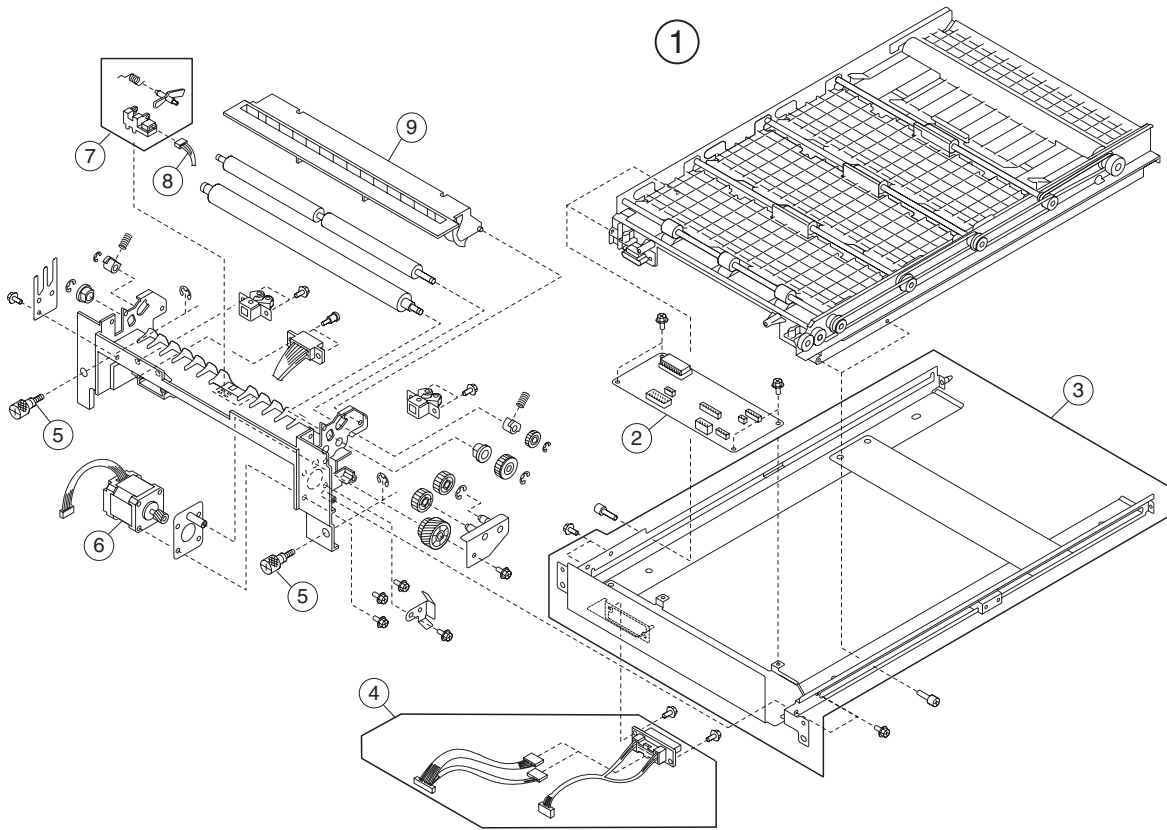

Assembly 17: Duplex Unit 1

Index	P/N	Units	Description
17-4	40X1252	1	Duplex assembly
2	40X1060	1	Board, duplex interface
3	40X1168	1	Frame, duplex
4	40X1172	1	Cable assembly, duplex connection
5	40X1169	2	Screw, duplex mounting
6	40X1170	1	Motor, duplex stepping
7	40X1171	1	Interrupter, photo
8	56P9806	1	Cable assembly, paper detection
9	56P9994	1	Plate, duplex guide
NS	56P9807	1	Cable assembly, duplex interface
NS	40X1271		Parts packet

Assembly 18: Duplex unit 2

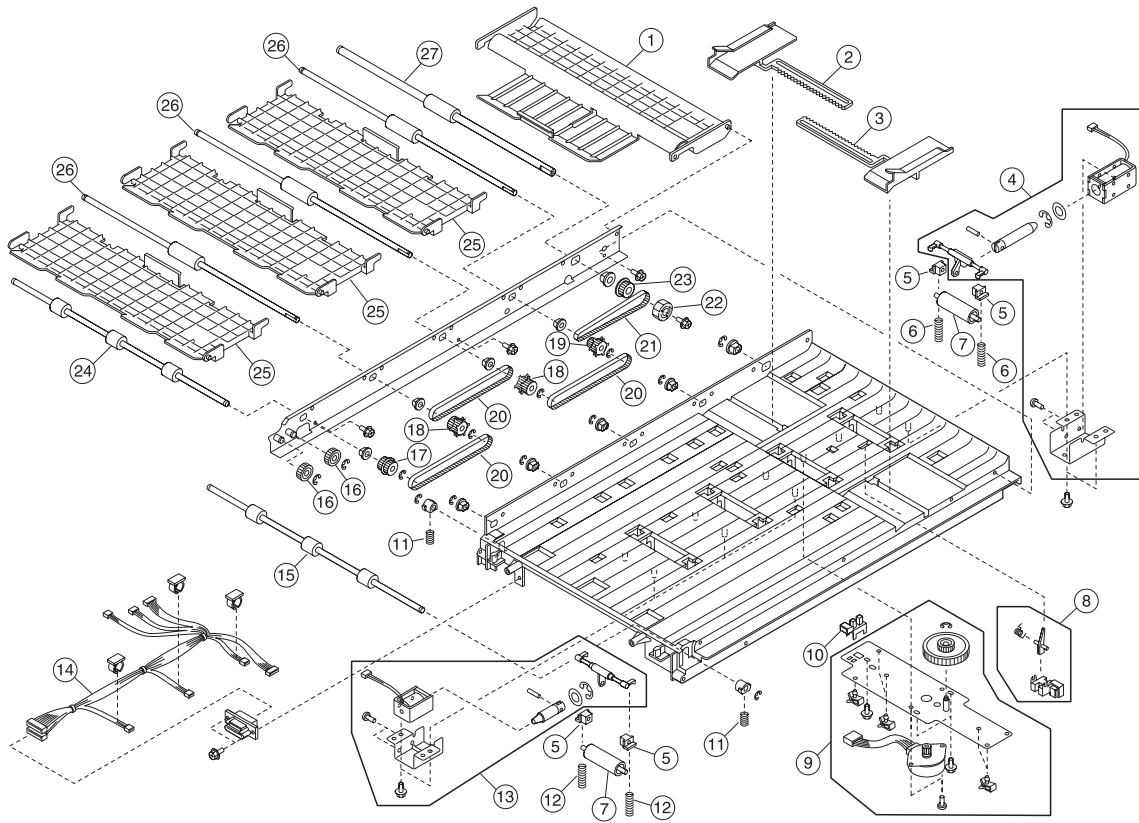

Assembly 18: Duplex unit 2

Index	P/N	Units	Description
18-4	56P9825	1	Plate, paper re-feed drawer
2	56P9827	1	Guide, rear side
3	56P9826	1	Guide, front side
4	40X1179	1	Solenoid assembly, paper re-feed
5	56P9814	8	Bearing, release
6	56P9816	2	Spring, re-feed roller
7	56P9813	4	Roll, release
8	40X1171	1	Interrupter, photo
9	56P9828	1	Motor assembly, paper guide
10	40X1173	1	Interrupter, photo
11	56P9526	2	Spring, feed roller
12	56P9815	6	Spring, reed roller
13	40X1178	3	Solenoid assembly, feed roller
14	40X1180	1	Cable assembly, duplex drawer
15	40X1175	1	Roller, follow-up feed
16	56P9527	2	Gear, idler
17	56P9817	1	Gear, carrying roller
18	56P9818	2	Pulley, carrying roller timing
19	56P9819	1	Pulley, feed roller
20	56P9822	3	Belt, timing
21	56P9823	1	Belt, timing
22	56P9821	1	Knob, paper re-feed
23	56P9820	1	Pulley, re-feed roller
24	40X1174	1	Roller, drive feed
25	56P9824	3	Plate, paper carrying drawer
26	40X1176	3	Roller, middle feed
27	40X1177	1	Roller, re-feed
NS	40X1271	1	Parts packet

Assembly 19: High-capacity feeder 1

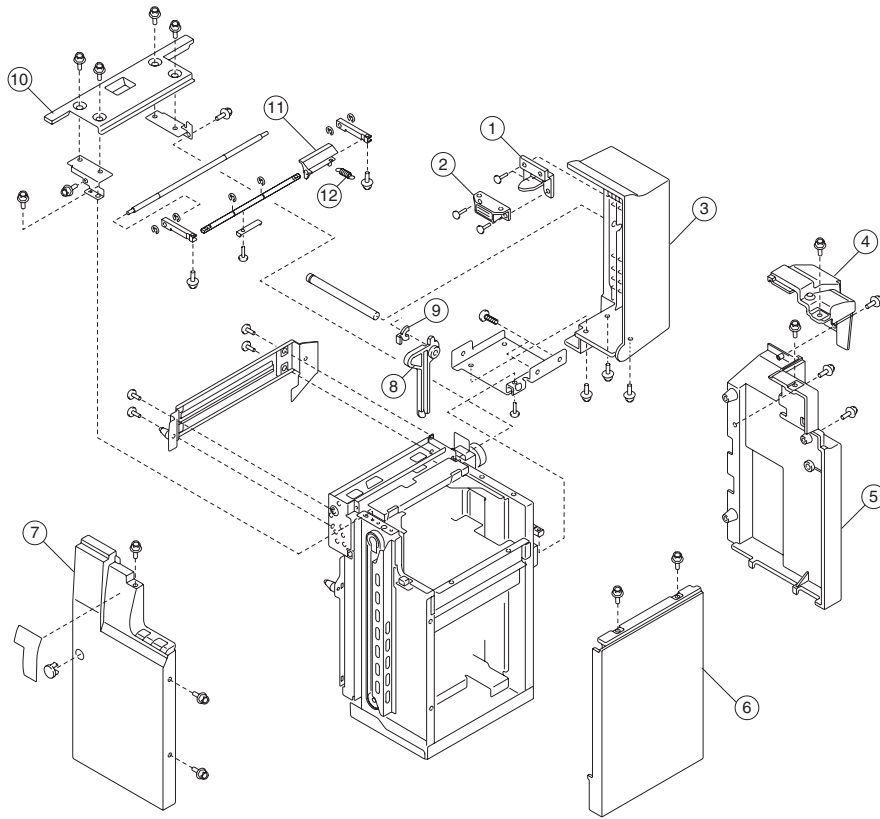

Assembly 19: High-capacity feeder 1

Index	P/N	Units	Description
19-4	40X1182	1	Catch, door
2	40X1181	1	Magnet, latch
3	40X1215	1	Cover, upper
4	40X1214	1	Cover, upper rear
5	40X1218	1	Cover, lower rear
6	40X1245	1	Cover, right
7	40X1213	1	Cover, front
8	56P9836	1	Fence, end
9	56P9940	1	Ring, snap
10	40X1217	1	Cover assembly, upper
11	40X1216	1	Lever, vertical transport
12	56P9842	1	Spring, tension
NS	40X1272	1	Parts packet

Assembly 20: High-capacity feeder 2

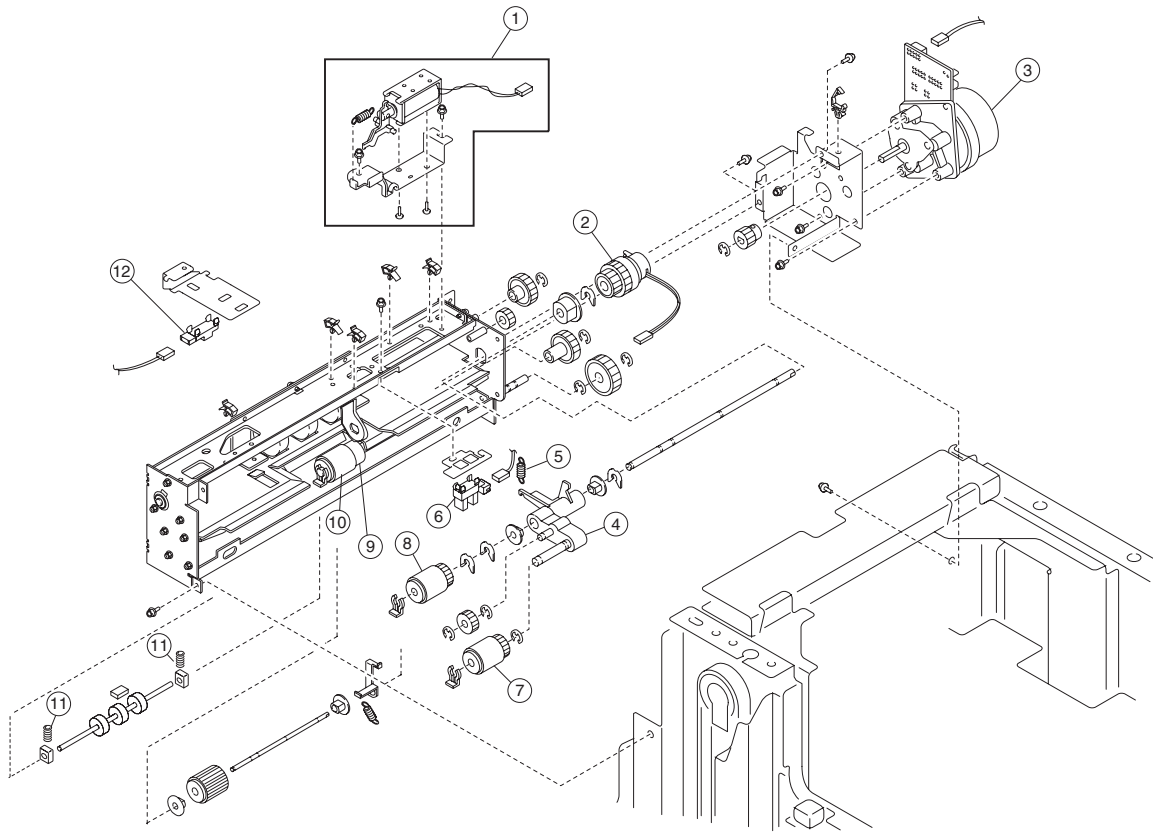

Assembly 20: High-capacity feeder 3

Index	P/N	Units	Description
20-4	40X1185	1	Solenoid assembly, paper pickup
2	40X1153	1	Clutch, paper feed
3	40X1183	1	Motor assembly, transport
4	56P9941	1	Arm, pick-up
5	56P9501	1	Spring, pressure
6	40X1184	1	Interrupter, photo
7	56P9849	1	Roller, manual feed pickup
8	56P9850	1	Roller, manual feed
9	56P9852	1	Limiter, torque
10	56P9851	1	Roller, manual feed separate
11	56P9847	2	Spring, compression
12	56P9845	1	Sensor assembly, paper feed
NS	40X1273	1	Parts packet

Assembly 21: High-capacity feeder 3

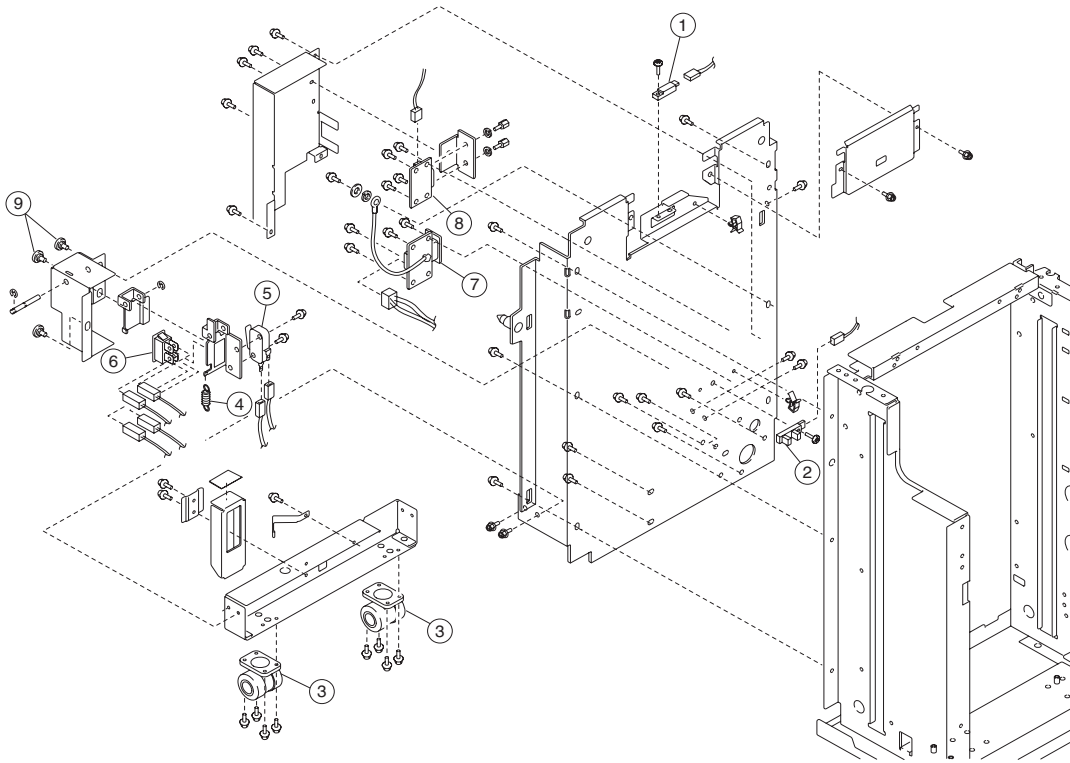

Assembly 21: High-capacity feeder 3

Index	P/N	Units	Description
21-4	40X1244	1	Sensor assembly, photo
2	40X1186	1	Interrupter, photo
3	56P9529	4	Caster, HCF
4	56P9856	1	Spring, tension
5	40X1188	1	Switch, micro
6	40X1187	1	Switch, push
7	40X1190	1	Connector, inlet
8	40X1189	1	Connector, I/F
9	56P9853	3	Screw, shoulder
NS	40X1274	1	Parts packet

Assembly 22: High-capacity feeder 4

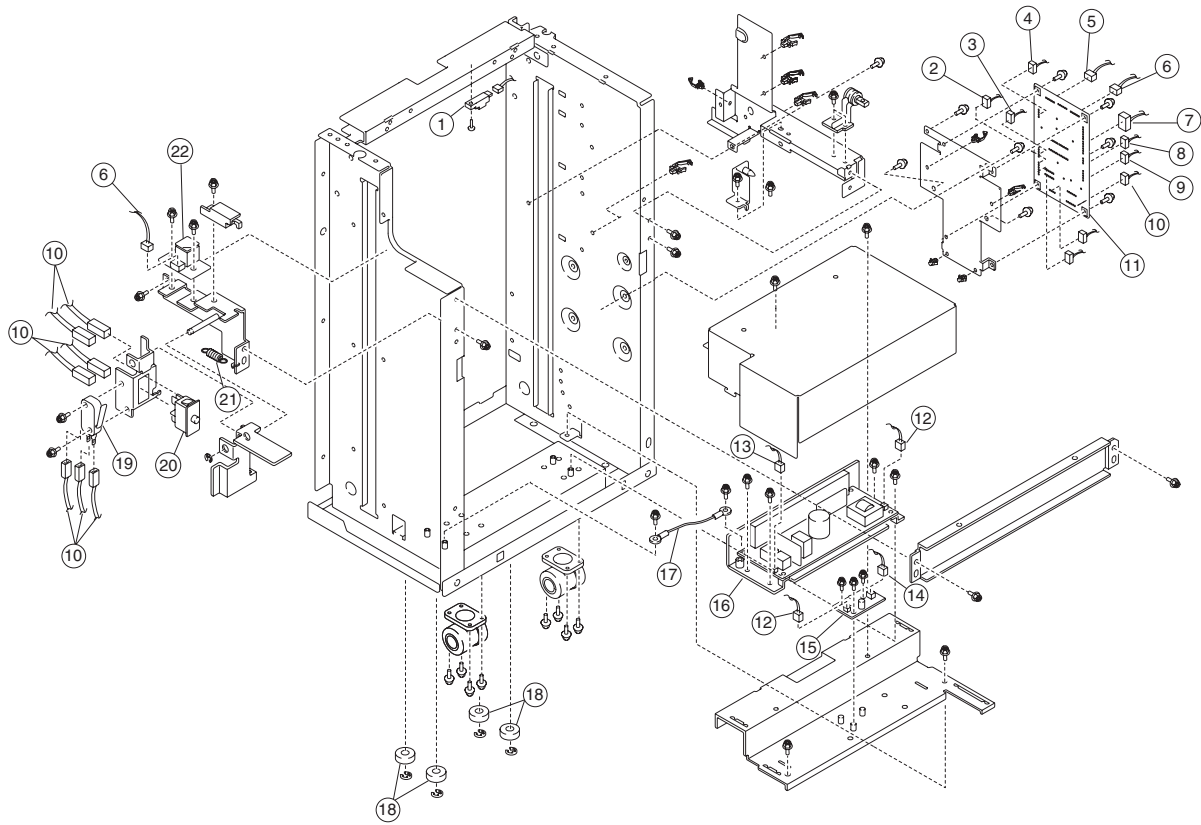

Assembly 22: High-capacity feeder 4

Index	P/N	Units	Description
22-4	40X1192	1	Sensor, resistor
2	40X3490	1	Cable assembly, safety switch
3	40X3486	1	Cable assembly, HCF motor
4	40X3489	1	Cable assembly, I/F
5	40X3487	1	Cable assembly, paper feed sensor
6	40X3495	1	Cable, up/down switch
7	40X3494	1	Cable, paper volume
8	40X3493	1	Cable assembly, sensor
9	40X9432	1	Cable assembly, paper size sensor
10	40X3491	1	Cable assembly, lift motor
11	40X1219	1	Board, high-capacity feed
12	40X1061	1	Cable assembly, power supply out
13	40X1194	1	Cable assembly, power supply in
14	40X1195	1	Cable assembly, power supply
15	40X1193	1	Converter, DC/DC
16	40X1062	1	Power supply, HCF
17	40X3488	1	Cable assembly, drawer ground
18	56P9861	4	Roller, track
19	40X3485	1	Switch, micro
20	40X1187	1	Switch, push
21	56P9501	1	Spring, pressure pickup
22	40X1191	1	Switch, HCF push
NS	40X1275	1	Parts packet

Assembly 23: High-capacity feeder 5

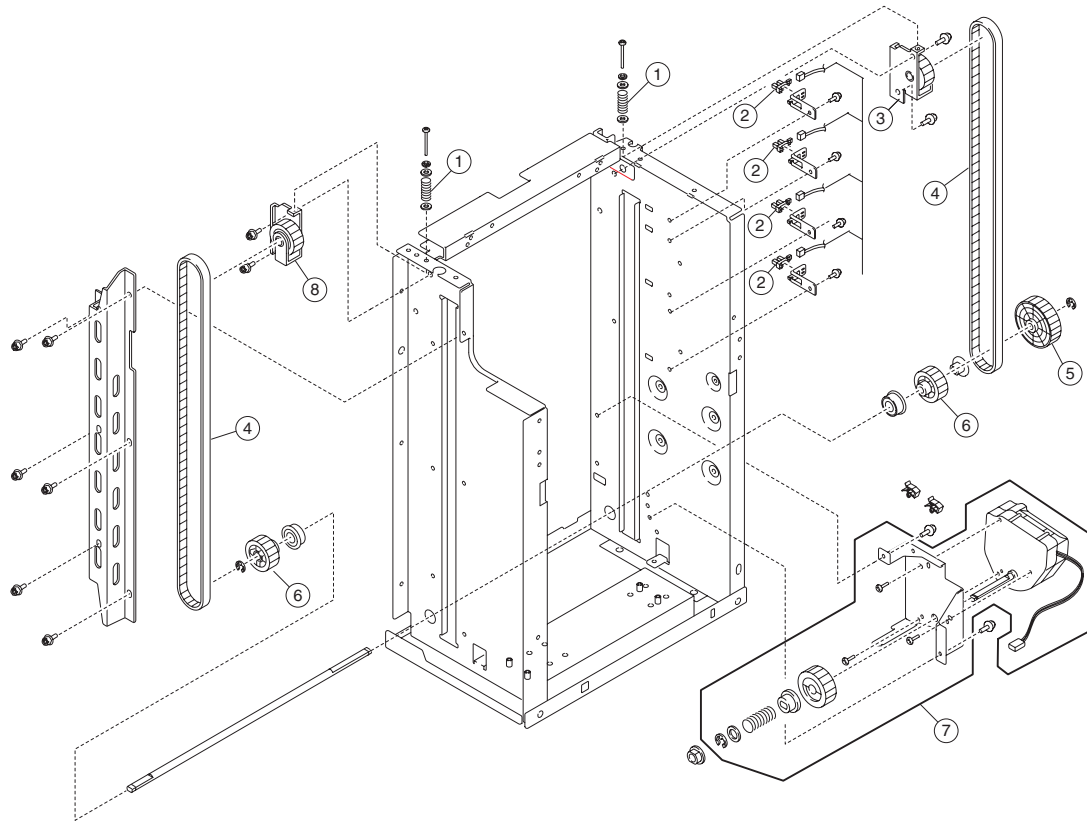

Assembly 23: High-capacity feeder 5

Index	P/N	Units	Description
23-4	56P9883	2	Spring, pressure
2	40X1184	4	Interrupter, photo
3	40X1198	1	Bracket, rear idler
4	56P9884	2	Belt, timing
5	56P9886	1	Gear, drive
6	56P9885	2	Pulley, timing
7	40X1196	1	Motor, HCF DC
8	40X1197	1	Bracket, front idler
NS	40X1521	1	Parts packet

Assembly 24: High-capacity feeder 6

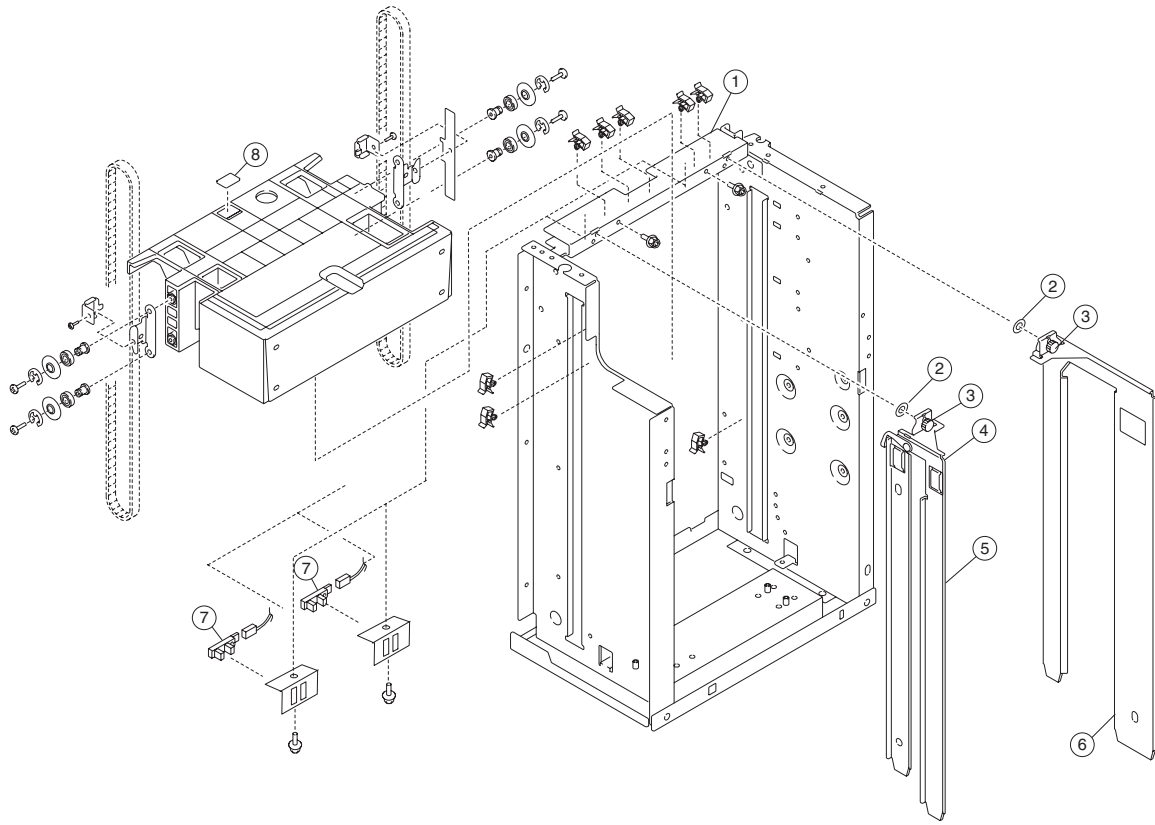

Assembly 24: High-capacity feeder 6

Index	P/N	Units	Description
24-1	40X1199	1	Plate, upper side fence
2	56P9893	2	Knob, stopper
3	56P9891	2	Knob, tray
4	56P9890	2	Plate, paper adhesion
5	56P9915	1	Fence assembly, front side
6	56P9894	1	Fence assembly, rear side
7	40X1184	2	Interrupter, photo
8	56P9889	1	Pad, friction
NS	40X1522	1	Parts packet

Assembly 25: Finisher covers

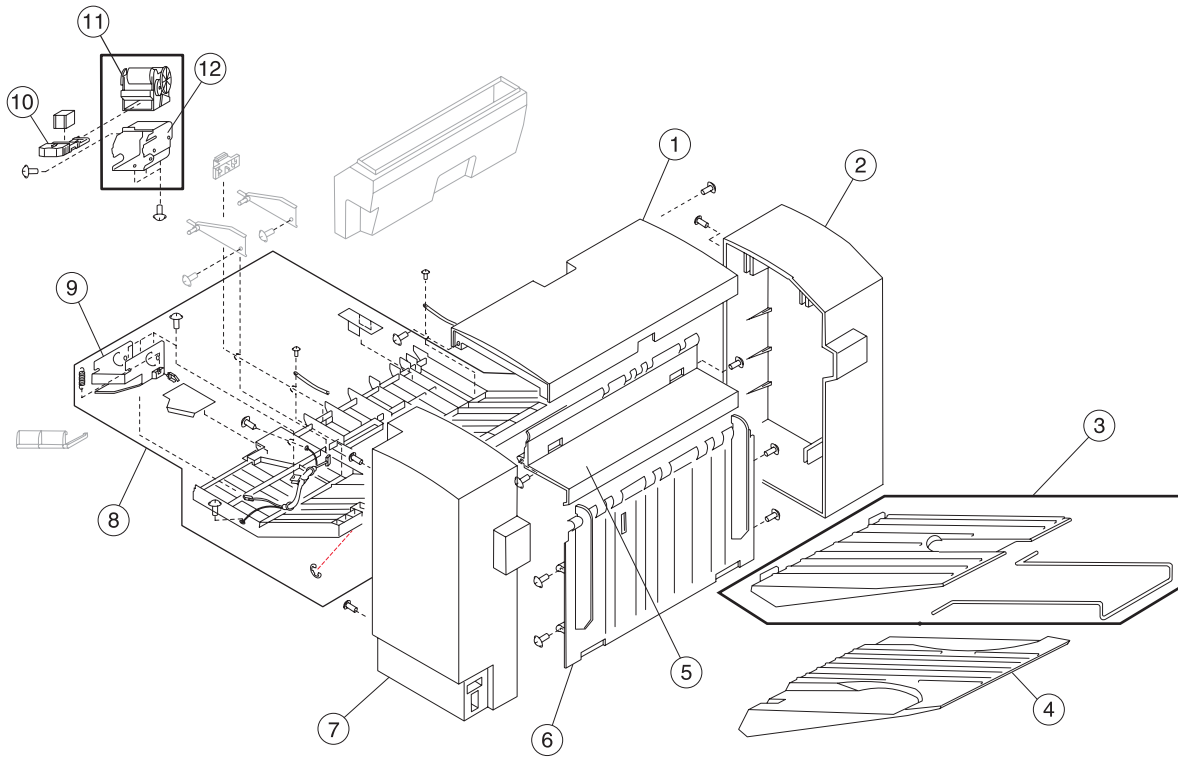

Assembly 25: Finisher covers

Index	P/N	Units	Description
25-1	56P4064	1	Cover, top
2	56P4065	1	Cover, front
3	56P4067	1	Tray, upper
4	56P4068	1	Tray, lower
5	56P4062	1	Panel, left upper
6	40X1227	1	Assembly, lower left panel
7	56P4066	1	Cover, rear
8	56P4063	1	Assembly, staple cover
9	56P9365	1	Cover, staple A
10	56P9367	1	Cartridge, staple
11	40X2622	1	Stapler
12	56P9364	1	Cover, staple B

Assembly 26: Finisher frame

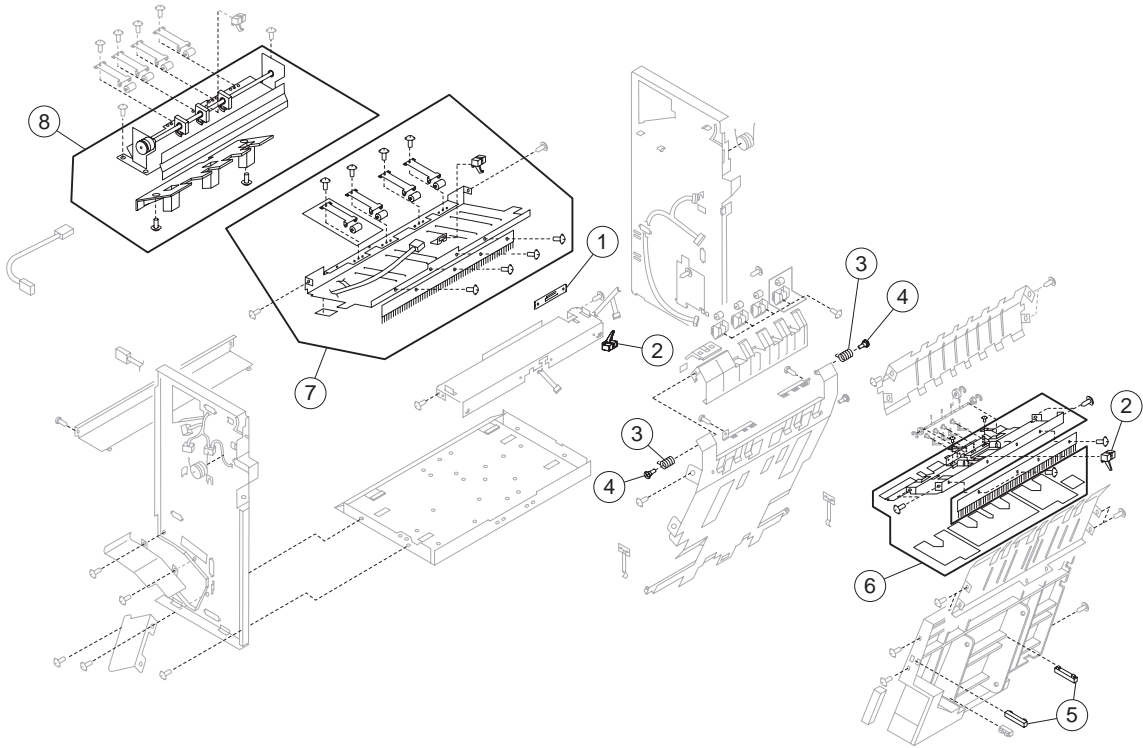

Assembly 26: Finisher frame

Index	P/N	Units	Description
26-1	56P4069	1	Handle
2	40X2628	2	Sensor, photo
3	56P9386	2	Spring
4	40X2626	2	Screw, M4
5	40X2607	1	Assembly, exit guide inverter
6	56P9399	2	Sensor, photo
7	40X1223	1	Assembly, exit guide straight
8	40X2608	1	Unit, 3 hole punch (U.S. only)
8	40X2609	1	Unit, 4 hole punch (non U.S.)
NS	56P4072	1	Kit, punch speed up

Assembly 27: Finisher feed 1

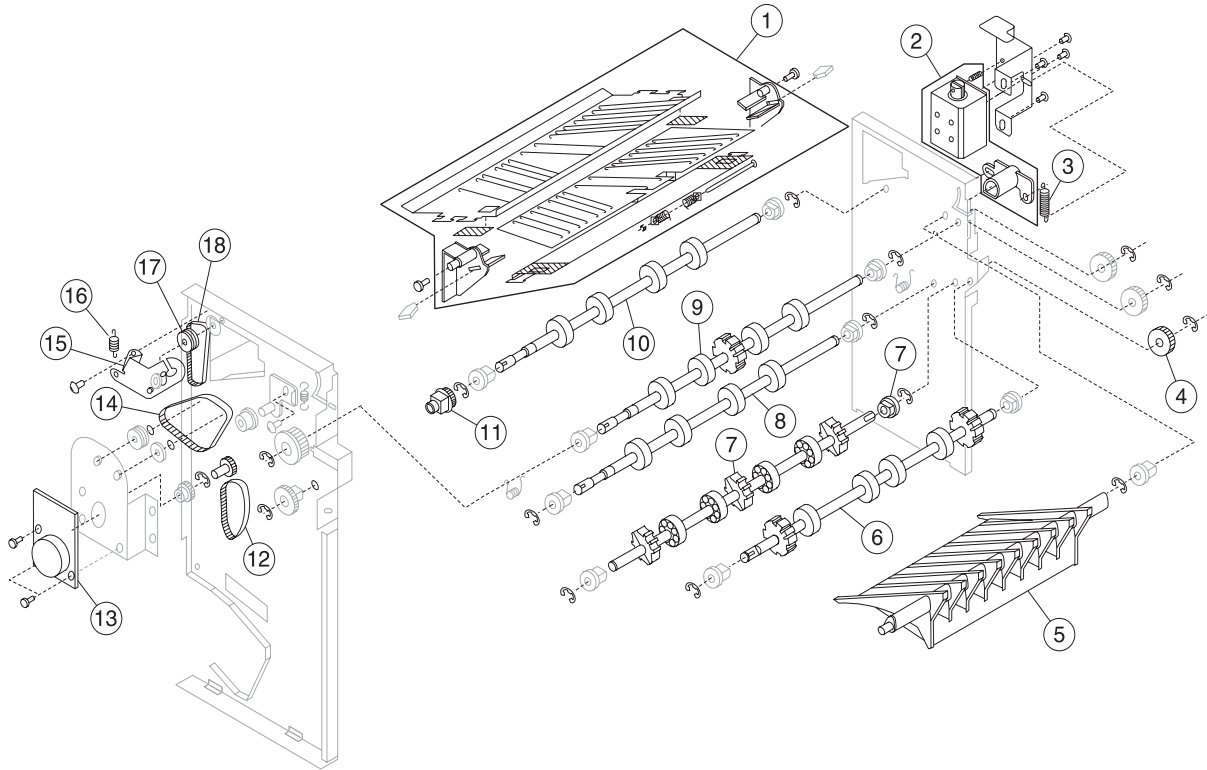

Assembly 27: Finisher feed 1

Index	P/N	Units	Description
27-1	40X2640	1	Assembly, guide plate
2	40X2615	1	Assembly, solenoid
3	56P9396	1	Spring, H
4	56P9398	1	Gear, Z19
5	56P9310	1	Gate
6	56P9400	1	Roller
7	56P9361	1	Roller, patting
8	56P9401	2	Roller, I
9	56P9312	1	Roller, F
10	56P9405	1	Roller, G
11	40X2616	1	Clutch, registration
12	56P9407	1	Belt, timing 60S2M184
13	40X2617	1	Assembly, feed motor
14	56P9339	1	Belt, timing 60S2M334
15	56P4060	1	Assembly, punch drive
16	56P9318	1	Spring, B
17	56P4070	1	Pulley gear Z36/T24
18	56P4061	1	Belt

Assembly 28: Finisher feed 2

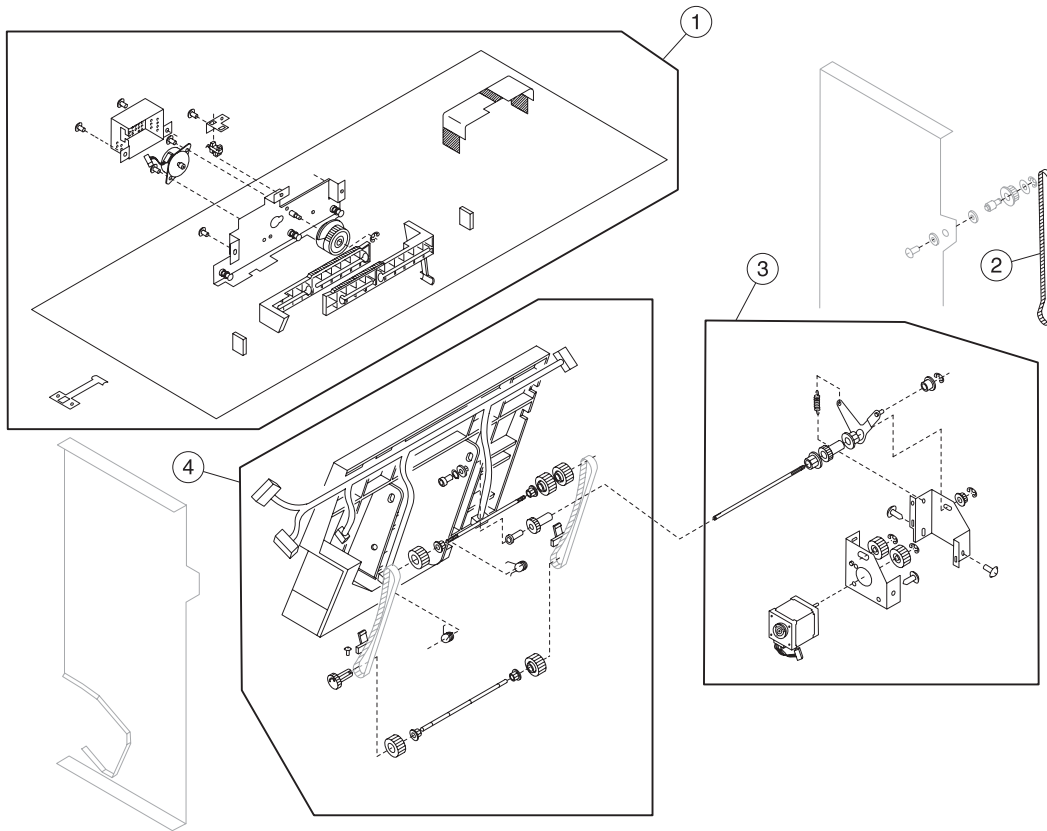

Index	P/N	Units	Description
28-1	40X2600	1	Assembly, jogging unit
2	56P9333	1	Belt, timing 60S3M408
3	40X2612	1	Assembly, tractor motor
4	40X2601	1	Assembly, guide stack

Assembly 29: Finisher elevator

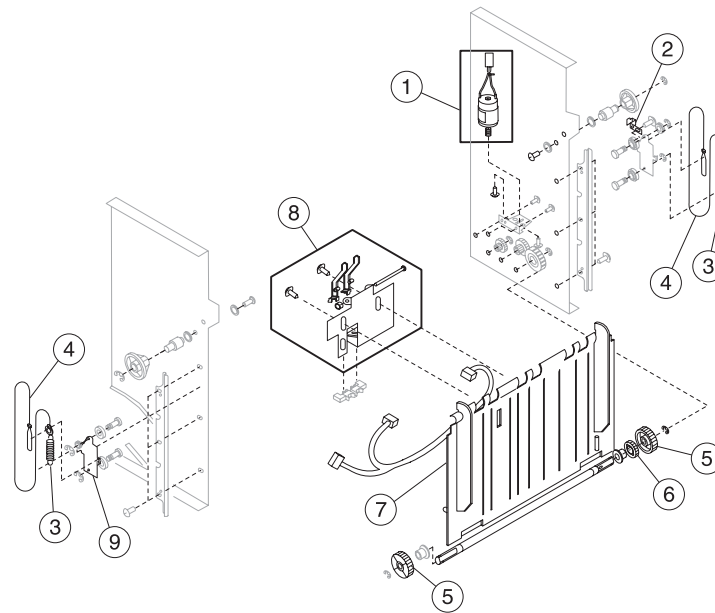

Index	P/N	Units	Description
29-1	40X2606	1	Assembly, elevator motor
2	56P9451	1	Shutter
3	56P9332	2	Spring, C
4	40X2614	2	Wire
5	56P9459	2	Drum, wire
6	56P9460	1	Gear, Z30
7	56P4073	1	Panel, lower left
8	40X2639	1	Assembly, sensor
9	40X2605	1	Assembly, hook rear

Assembly 30: Finisher electronics

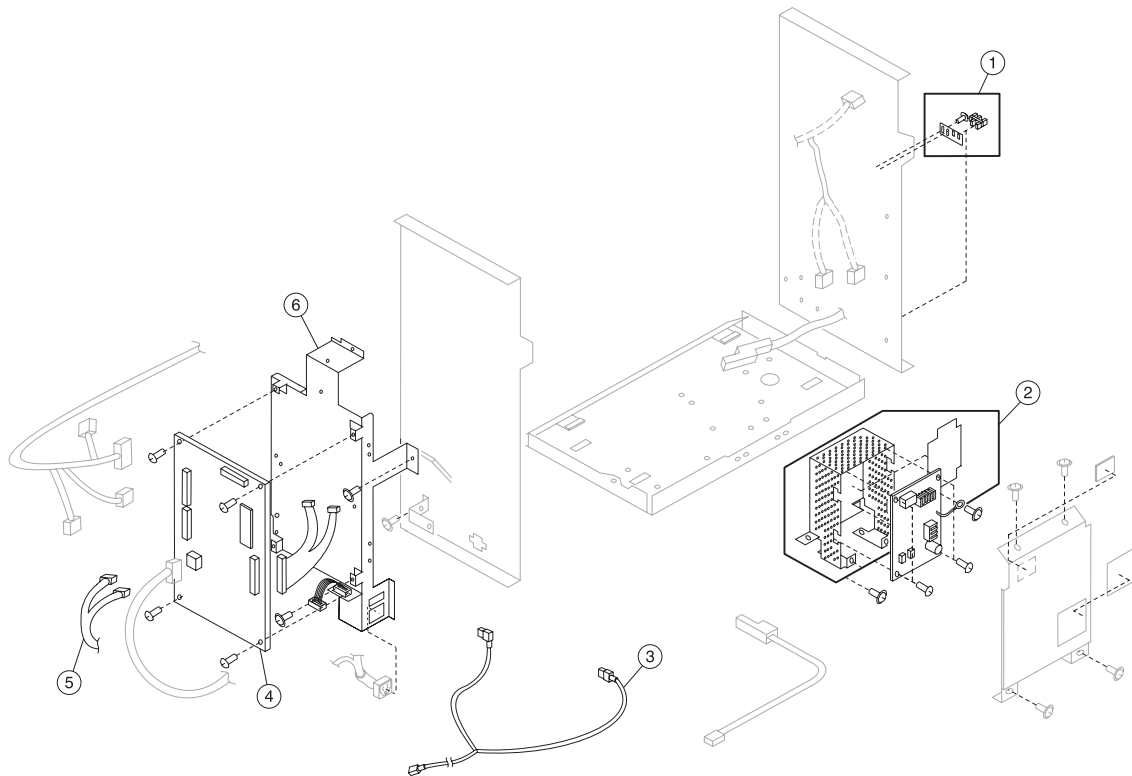

Index	P/N	Units	Description
30-1	40X2604	1	Assembly, upper limit sensor
2	40X2603	1	Supply, power
3	56P9358	1	Cord, Y power
3	56P9368	1	Cord, Y power (230 V only)
4	40X1225	1	Board, finisher control
5	56P9410	1	Cable
6	40X2618	1	Bracket, finisher control board
NS	56P9357	1	Cable, interface

Assembly 31: Finisher docking 1

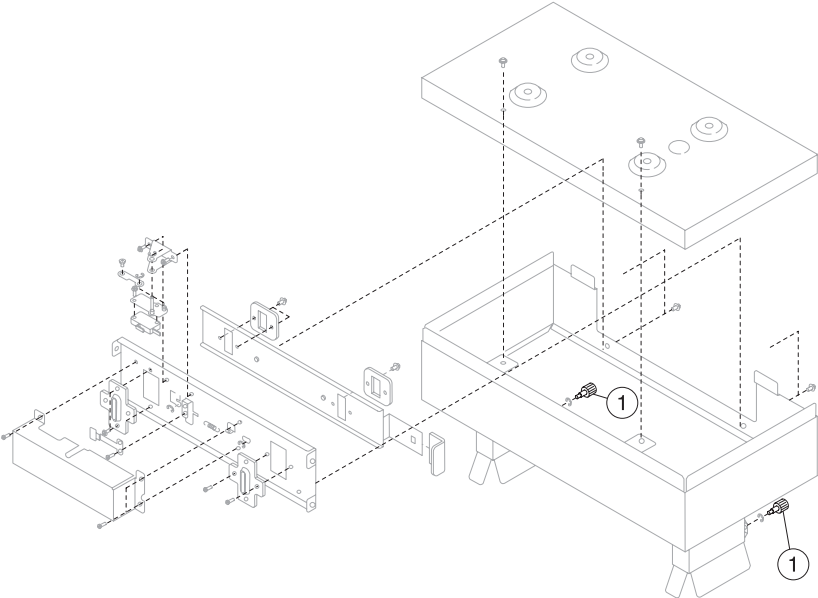

Index	P/N	Units	Description
31-1	56P9467	2	Screw, thumb

Assembly 32: Finisher docking 2

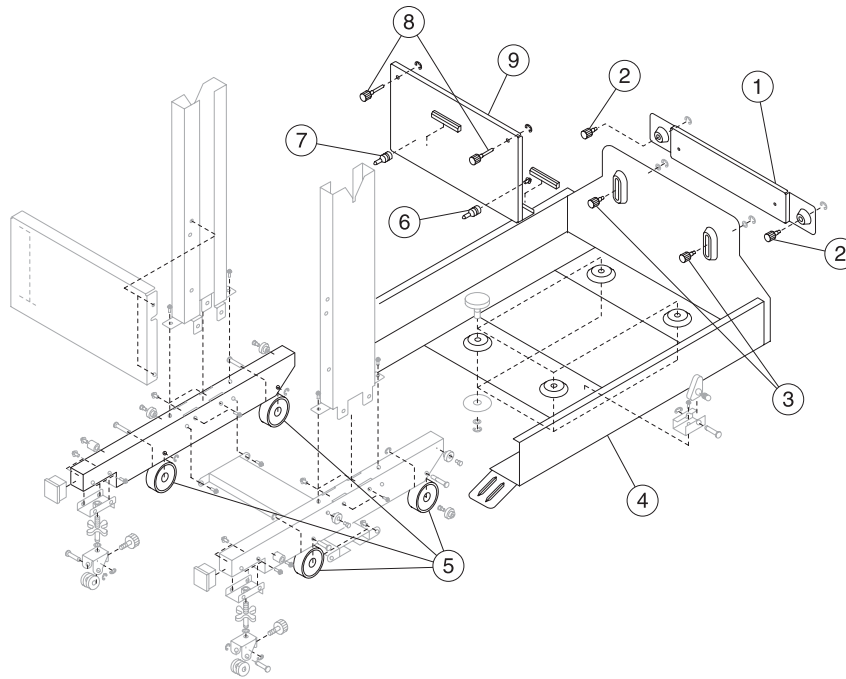

Index	P/N	Units	Description
32-1	40X1237	1	Bracket, rail
2	56P9472	2	Screw, lock
3	40X1238	1	Screw, rail
4	40X1239	1	Chassis, rail
5	56P9474	4	Roller
6	40X1241	1	Stud, lock-f
7	56P9473	1	Stud, lock
8	40X1240	1	Screw, lock
9	40X1254	1	Bracket, lock

Assembly 33: Miscellaneous/options

Index	P/N	Units	Description
NS	40X1508	1	Card assembly, 128MB SDRAM memory
NS	40X1509	1	Card assembly, 256MB SDRAM memory
NS	40X1510	1	Card assembly, 512MB SDRAM memory
NS	40X1512	1	Kit, Japanese font
NS	40X1564	1	Card asm, 32 MB flash memory
NS	40X1455	1	Card asm, 64 MB flash memory
NS	40X1513	1	Kit, Simplified Chinese font
NS	40X1514	1	Kit, Traditional Chinese font
NS	40X1515	1	Kit, Korean font
NS	40X1503	1	Card, bar code
NS	7374460	1	Kit, C920 dtn printer relocation
NS	40X1511	1	Kit, C920 net printer relocation
NS	40X1502	1	Card, IPDS
NS	40X1504	1	Card, Prescribe
NS	40X1505	1	Card, PrintCryptio TM
NS	40X1507	1	Card, forms (Double byte)
NS	40X2610	1	Drive assembly, hard file 40 gb (w/mounting kit)
NS	40X1375	1	Adapter, MarkNet TM N8000 10/100
NS	40X1376	1	Adapter, MarkNet N8020 10/1000
NS	40X1377	1	Adapter, MarkNet N8030 Fiber
NS	40X1378	1	Adapter, MarkNet N8050 Americas
NS	40X1562	1	Adapter, MarkNet N8050 Europe
NS	40X1561	1	Antenna, external
NS	40X0179	1	Grease, Nyogel 744
NS	40X1109	1	Kit, paperpath maintainence
NS	40X3483	1	Cable, hi cap feeder interface
NS	40X0290	1	Card, RS 232 serial interface
NS	40X0291	1	Card, 1284-B parallel interface

Assembly 34: Parts packets

Index	P/N	Units	Description
NS	40X1262	1	Parts packet, containing: <ul style="list-style-type: none"> • 5 Bind S-tight screws, 3x6, Zn-3R • 5 Bind S-tight screws, 3x15, Zn-3K • 5 Bind P-tight screws, 3x8, Zn-3K • 5 Bind P-tight screws, 3x10, Zn-3K • 5 Bind P-tight screws, 3x6, Zn-3K • 5 Bind P-tight screws, 3x8, Ni-3 • 5 Bind screws, M3x6, Ni-3
NS	40X1263	1	Parts packet, including: <ul style="list-style-type: none"> • 5 Bind S-tight screws, 3x6, Zn-3R • 5 Bind P-tight screws, 3x8, Zn-3K • 5 Bind P-tight screws, 3x10, Zn-3K • 5 Bind screws, M3x4, Zn-3K • 5 Bind screws, M3x8, Zn-3K • 5 Bind screws, M3x6, Ni-3 • 5 Screws with washers, M3x30, Zn-3K • 5 E-rings, ES-6, ACP
NS	40X1264	1	Parts packet, including: <ul style="list-style-type: none"> • 5 Bind S-tight screws, 3x6, Zn-3R • 5 Bind P-tight screws, 3x6, Zn-3K • 5 Bind P-tight screws, 3x8, Zn-3K • 5 Bind screws, M3x4, Zn-3K • 5 Bind screws, M3x6, Zn-3K • 5 Bind screws, M3x8, Zn-3K • 5 Pans with flange P-tight screws, 3x8, Zn-3K • 5 E-rings, ES-5, ACP • 5 E-rings, ES-6, ACP • 5 Spring pins, 2x10, ACP
NS	40X1265	1	Parts packet, including <ul style="list-style-type: none"> • 5 Bind S-tight screws, 3x6, Zn-3R • 5 Bind S-tight screws, 3x8, Zn-3R • 5 Bind P-tight screws, 3x8, Zn-3K • 5 E-rings, ES-4, ACP

Assembly 34: Parts packets (continued)

Index	P/N	Units	Description
NS	40X1266	1	Parts packet, including: <ul style="list-style-type: none"> • 5 Bind S-tight screws, 3x6, Zn-3R • 5 Bind P-tight screws, 3x6, Zn-3K • 5 Bind P-tight screws, 3x8, Zn-3K • 5 E-rings, ES-3, ACP • 5 E-rings, ES-5, ACP • 5 E-rings, ES-6, ACP • 5 Spring pins, 2x10, ACP • 5 Bind screws, M3x8, Zn-3K • 5 Bind screws M2x8, Ni-3
NS	40X1267	1	Parts packet, including: <ul style="list-style-type: none"> • 5 Bind S-tight screws, 3x6, Zn-3R • 5 Bind S-tight screws, 3x8, Zn-3R • 5 Bind S-tight screws, 3x12, Zn-3R • 5 Bind P-tight screws, 3x8, Zn-3K • 5 Bind screws, M3x4, Zn-3K • 5 Bind screws, M3x6, Zn-3K • 5 Bind screws, M3x12, Zn-3K • 5 Pans with flange P-tight screws, 3x10, Zn-3K • 5 Screws with washers, M3x30, Zn-3K • 5 Screws with washers, M4x8, Zn-3K • 5 Screws with washers, M4x12, Zn-3K • 5 Screws with washers, M3x6, Ni-3(BS) • 5 Screws with washers, M4x8, Ni-3(BS) • 5 Screws with spring-washers, M3x8, Ni-3(BS) • 5 Screws with spring-washers, M4x8, Ni-3(BS) • 5 Natt with flange sereit, M3, Ni-3 • 5 E-rings, ES-2.5, ACP • 5 Spring pins, 3x10, ACP
NS	40X1268	1	Parts packet, including: <ul style="list-style-type: none"> • 5 Bind S-tight screws, 3x6, Zn-3R • 5 Bind screws, M3x6, Zn-3K • 5 Bind screws, M3x10, Zn-3K • 5 Bind screws, M3x6, Ni-3
NS	40X1269	1	Parts packet, including: <ul style="list-style-type: none"> • 50 Bind S-tight screws, 3x6, Zn-3R • 50 Bind screws, M3x6, Zn-3K • 50 Bind screws, M3x8, Ni-3 • 50 E-rings, ES-5, ACP



















Assembly 34: Parts packets (continued)

Index	P/N	Units	Description
NS	40X1270	1	Parts packet, including: <ul style="list-style-type: none"> • 5 Bind S-tight screws, 3x6, Zn-3R • 5 Bind S-tight screws, 3x8, Zn-3R • 5 Bind P-tight screws, 3x6, Zn-3K • 5 Bind P-tight screws, 3x8, Zn-3K • 5 Bind screws, M3x4, Zn-3K • 5 Bind screws, M3x6, Zn-3K • 5 E-rings, ES-5, ACP • 5 E-rings, ES-6, ACP • 5 Spring pins, 2x10, ACP • 5 Spring pins, 3x10, ACP
NS	40X1271	1	Parts packet, including: <ul style="list-style-type: none"> • 5 E-rings, ES-3, ACP • 5 E-rings, ES-4, ACP • 5 E-rings, ES-6, ACP • 5 R-screws, M3x6 • 5 R-screws, M3x8 • 5 R-screws, M4x6 • 5 Pans S-tight screws, M3x6 • 5 RP-tight screws, M3x8,
NS	40X1272	1	Parts packet, including: <ul style="list-style-type: none"> • 5 Bind S-tight screws, 3x6, Zn-3R • 5 Bind P-tight screws, 4x8, Zn-3R • 5 Pan screws, M4x6 Zn-3R • 5 Pan screws, M4x12, Zn-3R • 5 E-rings, ES-6, ACP • 5 RP-tight screws, M4x12 • 5 RS-tight screws, M4x6 • 5 RS-tight screws, M4x8 • 5 RS-tight screws, M4x12
NS	40X1273	1	Parts packet, including: <ul style="list-style-type: none"> • 5 E-rings, ES-3, ACP • 5 E-rings, ES-4, ACP • 5 E-rings, ES-6, ACP • 5 RS-set screw cp, M3x3, Zn-3K • 5 RS-tight screws, M4x6 • 5 RS-tight screws, M4x8

Assembly 34: Parts packets (continued)

Index	P/N	Units	Description
NS	40X1274	1	Parts packet, including: <ul style="list-style-type: none"> • 5 Bind S-tight screws, 3x10, Zn-3R • 5 E-rings, ES-4, ACP • 5 RS-tight screws, M3x14 • 5 RS-tight screws, M4x6 • 5 RS-tight screws, M4x8 • 5 RS-tight round top screws, M3x6
NS	40X1275	1	Parts packet, including: <ul style="list-style-type: none"> • 5 E-rings, ES-4, ACP • 5 RS-tight screws, M3x8 • 5 RS-tight screws, M3x14 • 5 RS-tight screws, M4x6 • 5 RS-tight screws, M4x8
NS	40X1521	1	Parts packet, including: <ul style="list-style-type: none"> • 5 ZM 3R screws 4x30 • 5 E-rings, ES-5, ACP • 5 ZN 3R washers • 5 RS-tight screws, M4x6
NS	40X1522	1	Parts packet, including: <ul style="list-style-type: none"> • 5 Bind S screws, 3x8 • 5 Bind S screws, 4x6 • 5 Pan screws 4x20 • 5 RS-tight screws, M4x6 • 5 RS tight round top screws • 5 E-rings, ES-6, ACP

Assembly 35: Finisher parts packet P/N 402623

Pin		Retaining Ring -E Type	
Screw		Spring Pin	
Screw		Screw	
Tapping Screw		Spring Lock Washer	
Tapping Screw		Toothed Lock Washer	
Tapping Screw		Resin Ring	
Tapping Screw		Nut	
Set Screw		Tapping Screw	
Plain Washer		Tapping Screw	
		Screw	