

KONICA MINOLTA

# *PARTS GUIDE MANUAL*

---

*JUNE 2005*

*bizhub C351*

*bizhub C450*

## INFORMATION FOR PARTS GUIDE MANUAL

To find correct Parts No., refer to the "HOW TO MAKE THE BEST USE OF THIS MANUAL" in the following page.

### HOW TO MAKE THE BEST USE OF THIS MANUAL

- 1 When you order, please check the proper figures beforehand that are on Our Parts Guide Manual, and order with the appropriate figures.
- 2 For screws, Nuts, Washers, retaining rings and Pins which are used in this model, one letter is shown on the Standard parts column of Parts list and exploded diagrams.
- 3 In order to maintain safety of the product, some specific parts composed of this product are set up as "essential safety parts".
- 4 The assigned parts number for the "essential safety parts" is indicated as "SP00-\*\*\*\*".  
When replacing these parts, follow precautions for disassembling and installing which are listed in the Service Manual.  
Do not use any parts that are not set up as
- 5 ♣ means that there are exclusive parts for each destination.  
Please check the appropriate destination when you order.
- 6 Revision Mark  
Marked as ▲ on the illustration shows that the revision has been made.
- 7 All rights reserved. (any reprints or quotations are prohibited.)  
Use of this parts guide manual should be strictly supervised to avoid disclosure of confidential information.

## パーツガイドマニュアルのご案内

サービス部品をご発注の際には、下記に示す“パーツガイドマニュアルの活用にあたって”をご参照の上、正しい部品番号にてお願い致します。

### パーツガイドマニュアルの活用にあたって

- 1 部品発注の際には、掲載されている部品番号の桁数を確認し、掲載されている桁数で発注願います。
- 2 この製品に使用されているネジ、ナット、ワッシャー、止め輪、ピンなどは、リストの右側の Standard parts 欄に a,b,c,……で表示し、イラストにも a,b,c,……表示してあります。
- 3 製品の安全性を維持する為に、製品に使用される特定の部品を「重要保安部品」として設定しています。
- 4 重要保安部品の部品番号は、“SP00-\*\*\*\*”と記載されていますので、部品交換時は、サービスマニュアル記載の分解・組み立ての注意事項に従って作業をして下さい。  
また、指定以外の部品は一切使用しないで下さい。
- 5 本文に ♣ が表示されている部品は、仕向け地毎に専用部品がある事を意味しています。  
オーダーされる時は、仕向け地を確認して下さい。
- 6 改訂記号について  
イラスト上に ▲ 印が表示されている部分は、改訂された事を表します。
- 7 著作権所有（無断転載及び無断引用の禁止）  
本パーツガイドマニュアルについては、機密保持等その扱いには十分注意して下さい。万一取り扱いを誤った場合には、法律で処罰されることがあります。

# SYSTEM OUTLINE

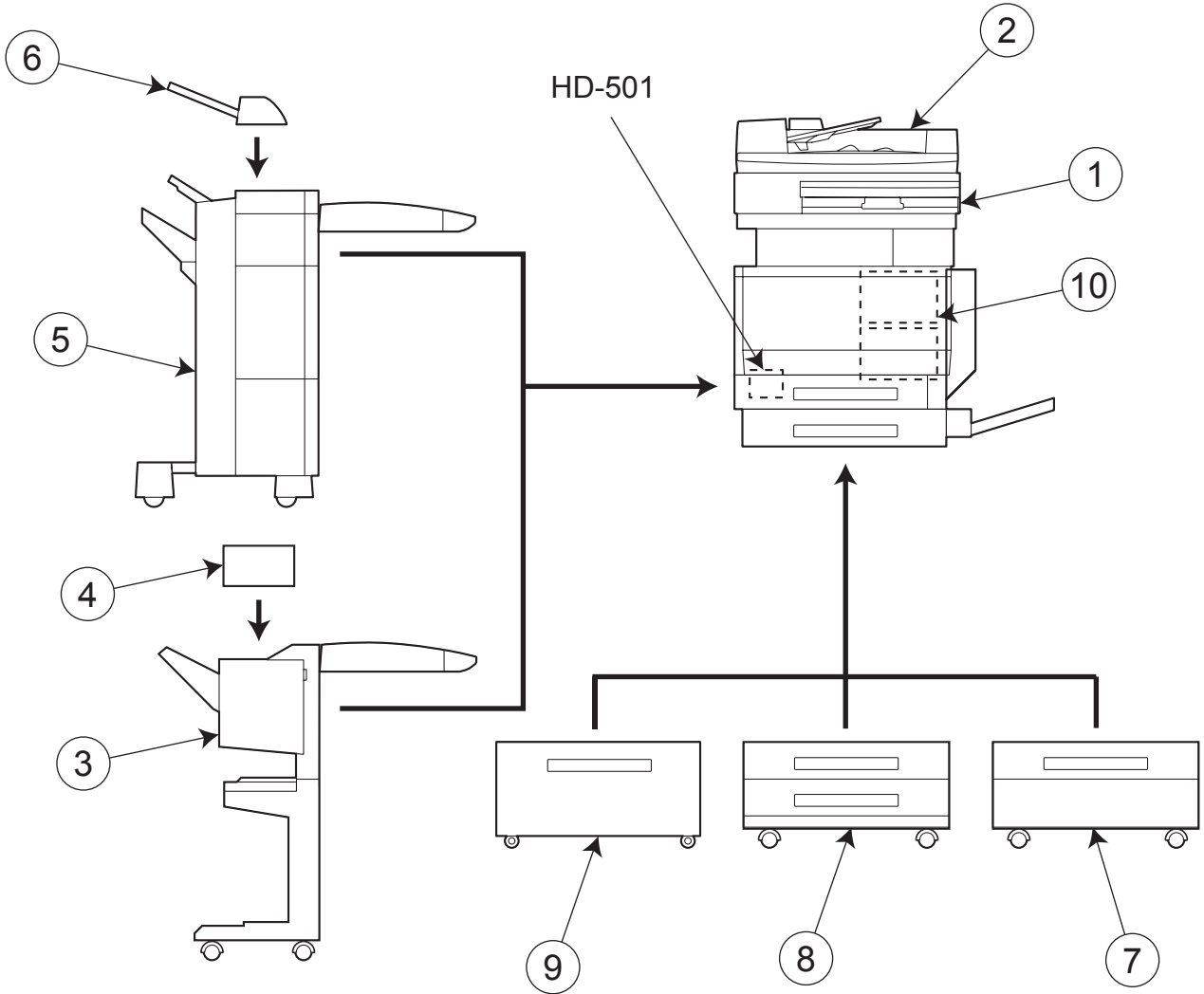

# GENERAL CONTENTS

<b>No.</b>	<b>Description</b>	<b>Model</b>
1	DIGITAL MFP COLOR	bizhub C351/bizhub C450
2	DOCUMENT FEEDER	DF-601
3	SORTER/FINISHER	FS-603
4	PUNCH UNIT	PK-501/PK-4/PK131
5	SORTER/FINISHER	FS-507
6	STACKER	JS-601
7	PAPER FEEDER	PC-102
8	PAPER FEEDER	PC-202
9	PAPER FEEDER	PC-402
10	FAX CONTROLLER	FK-502

# DIAGRAMS OF MAIN PARTS SECTION

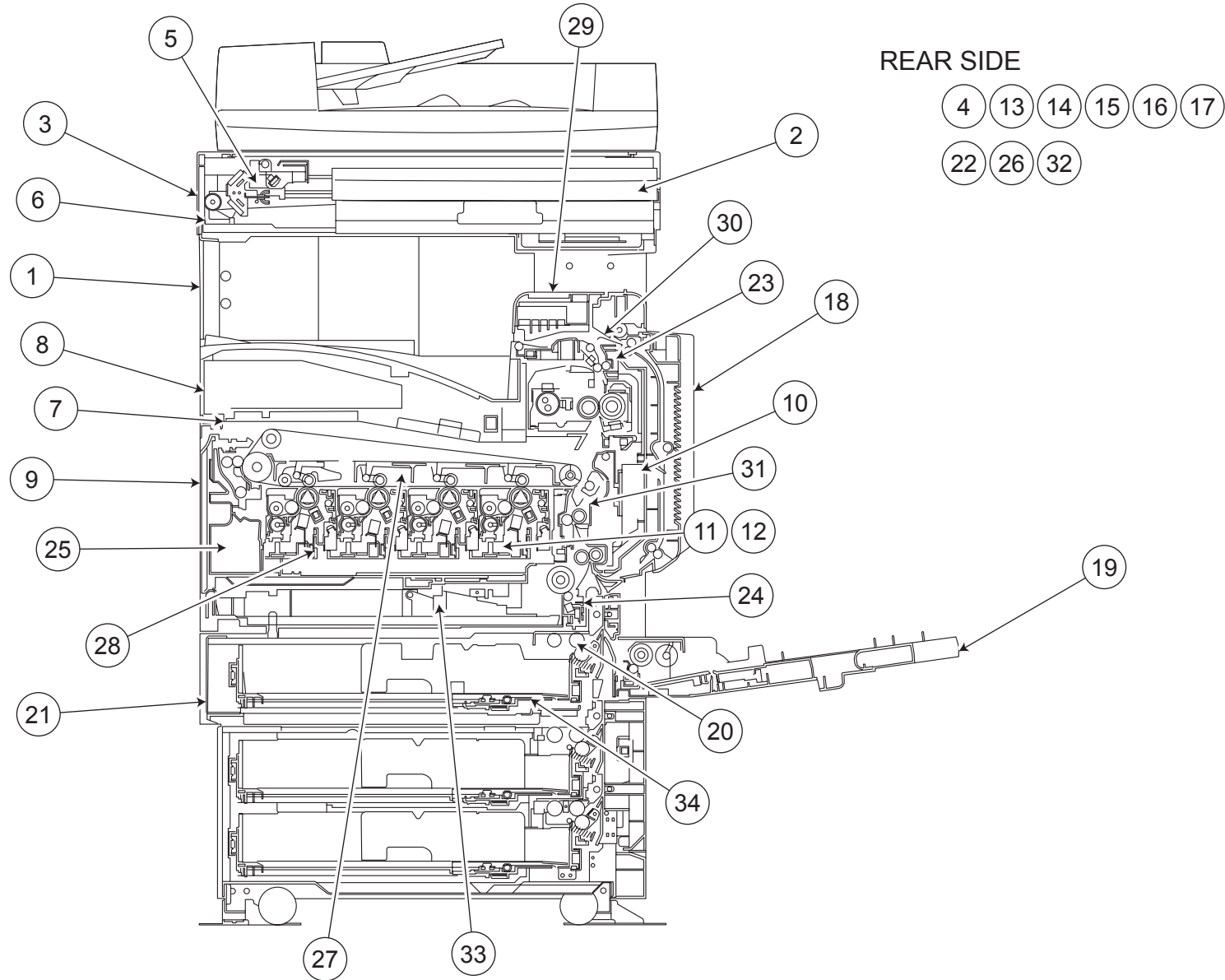

# CONTENTS

No.	DESCRIPTION	名称	PAGE No.
1	EXTERNAL PARTS	外装	P1
2	CONTROL PANEL	操作パネル	P2
3	IR COVER	I R カバー	P3
4	SCANNER DRIVE SECTION	スキャナ駆動	P4 P5
5	OPTICAL SECTION	光学部	P6
6	IR FRAME	I R フレーム	P7
7	MAIN FRAME	メインフレーム	P8
8	POWER UNIT	電源ユニット	P9
9	LEFT SIDE DOOR	右側扉	P10
10	MAIN SWITCH SECTION	メインスイッチ	P11
11	PAPER SELECT SWITCH & LED LOCK	L E D ロック	P12
12	HOPPER SECTION	ホッパー	P13 P14
13	OZONE FAN SECTION	オゾンファン	P15
14	PC DRIVE SECTION	P C 駆動	P16
15	DRIVE SECTION	駆動	P17
16	YMC DRIVE SECTION	Y M C 駆動	P18
17	FUSING DRIVE SECTION	定着駆動	P19 P20
18	DUPLEX UNIT	両面ユニット	P21 P22
19	MULTI MANUAL FEED SECTION	手差し給紙	P23 P24 P25
20	PAPER TAKE-UP SECTION	給紙	P26 P27 P28
21	CASSETTE FRAME	カセットフレーム	P29
22	CASSETTE DRIVE SECTION	カセット駆動	P30
23	FUSING SECTION	定着	P31
24	PAPER DETECT SECTION	給紙検出	P32 P33
25	TRANSFER SECTION	トナー搬送	P34
26	TRANSFER FRAME	搬送フレーム	P35
27	TRANSFER BELT UNIT	転写ベルトユニット	P36
28	LED UNIT	L E D ユニット	P37 P38 P39
29	FUSING COOL SECTION	定着排気	P40
30	PAPER EXIT DRIVE SECTION	排紙駆動	P41
31	PAPER TRANSPORT SECTION	転写・搬送	P42 P43 P44 P45 P46 P47
32	ELECTRICAL COMPONENTS	電装	P48
33	MULTIPURPOSE CASSETTE	マルチパーパスカセット	P49 P50
34	UNIVERSAL CASSETTE	ユニバーサルカセット	P51 P52
35	WIRING	束線	P53 P54 P55 P56 P57
36	WIRING ACCESSORIES AND JIGS	配線部品・治具	P58
37	ACCESSORY PARTS	同梱部品	P59

# INDEX

Parts No.	Page No.
0990 6304 02	11-3
0992 3014 01	52-18
0996 3055 01	8-9
0996 3055 01	29-10
1050 4805 01	58-22
1052 4301 01	58-23
1053 4812 01	58-14
1065 3086 01	26-21
1065 5872 02	58-15
1067 2501 01	26-18
1067 2502 01	25-5
1079 2219 01	37-5
1129 7303 01	5-26
1129 7303 01	17-45
1129 7303 01	32-16
1129 7303 01	34-21
1129 7303 01	39-7
1139 1612 01	5-17
1144 3097 03	50-16
1144 5336 02	14-22
1154 4670 01	17-38
1154 4670 01	29-29
1154 4670 01	48-33
1154 5158 01	36-2
1156 1371 01	4-2
1156 7501 01	59-1
1164 0108 02	32-14
1164 2046 01	31-16
1164 2047 03	31-14
1164 2080 01	32-13
1164 3003 01	50-18
1164 3004 03	50-22
1164 3005 02	50-23
1164 3009 01	49-9
1164 3020 03	32-17
1164 3022 02	32-19
1164 3027 01	32-11
1164 3045 01	49-31
1164 3053 12	32-5
1164 3054 01	32-24

Parts No.	Page No.
1164 3061 01	49-12
1164 3062 01	49-13
1164 3064 01	49-2
1164 3065 01	50-9
1164 3066 01	50-5
1164 3504 03	44-14
1164 3508 01	45-6
1164 3509 01	45-15
1164 3527 02	44-15
1171 1321 01	2-3
1174 7901 01	58-30
1200 1342 05	19-13
1200 1342 05	25-23
1200 1462 01	50-2
1200 1462 01	52-24
1200 1462 03	50-3
1200 1646 03	41-20
1200 2105 05	8-5
1200 2105 05	11-8
1200 2105 07	31-26
1200 3120 02	19-25
1200 3120 03	20-17
1200 3121 09	43-19
1200 3131 08	17-14
1200 3131 08	20-7
1200 3221 04	41-29
1200 5211 05	8-8
1200 5211 05	11-5
1200 5211 08	31-24
1200 5212 04	23-3
1274 2611 01	22-4
1274 2611 01	25-11
1274 2611 01	41-10
1274 2611 01	46-10
1274 3603 01	52-26
1300 3322 17	25-17
1300 4342 07	17-3
1300 4342 07	19-11
1483 0751 00	18-21
1483 0757 00	1-22

Parts No.	Page No.
1483 0762 00	44-20
1483 0769 00	32-10
1484 0751 00	22-11
1500 2320 02	9-19
1500 2640 04	14-13
1500 2660 13	50-4
1500 2660 13	52-25
4002 1422 02	5-14
4002 1423 01	5-12
4002 1456 01	5-5
4002 1458 01	4-14
4002 1480 01	5-16
4002 1591 01	7-2
4002 2581 01	29-3
4002 2581 01	30-17
4002 3108 01	52-22
4002 3110 01	30-24
4002 3131 01	30-25
4002 7306 01	52-3
4004 0105 05	39-13
4004 0207 01	16-4
4004 1012 02	10-24
4004 1014 01	10-20
4004 1017 01	14-15
4004 1030 01	14-19
4004 1031 03	1-14
4004 1041 01	14-17
4004 1066 03	10-23
4004 1067 02	10-10
4004 1069 02	9-10
4004 1071 01	12-19
4004 1072 01	10-9
4004 1712 01	38-15
4004 1719 01	38-14
4004 1805 01	12-15
4004 1805 01	38-13
4004 1807 01	38-5
4004 1819 02	38-19
4004 1822 01	12-5
4004 1823 01	12-12

Parts No.	Page No.
4004 1826 03	12-3
4004 1829 02	12-16
4004 1831 01	12-10
4004 1832 01	12-11
4004 1833 03	12-7
4004 1834 02	12-6
4004 1835 02	12-9
4004 1836 02	12-17
4004 1838 02	12-13
4004 1842 01	12-14
4004 2021 03	11-6
4004 2025 01	8-4
4004 2025 01	11-7
4004 2026 01	8-6
4004 2026 01	11-9
4004 2141 01	15-16
4004 2142 01	15-15
4004 2143 01	32-12
4004 2144 01	37-24
4004 2148 01	15-18
4004 2155 01	37-33
4004 2203 01	48-13
4004 2209 05	16-17
4004 2222 01	37-18
4004 2227 03	37-23
4004 2230 03	15-14
4004 2234 01	37-2
4004 2239 03	10-5
4004 2248 02	20-19
4004 2253 02	16-18
4004 2254 01	10-6
4004 2255 02	10-3
4004 2257 01	9-8
4004 2258 01	9-7
4004 2266 01	21-13
4004 2317 01	35-4
4004 2317 01	37-29
4004 2317 01	39-6
4004 2401 01	39-8
4004 2503 01	17-21

Parts No.	Page No.
4004 2503 01	18-8
4004 2509 01	17-18
4004 2509 01	18-11
4004 2540 01	17-1
4004 2545 01	17-9
4004 2546 01	17-11
4004 2547 01	17-4
4004 2569 01	20-14
4004 2570 02	20-13
4004 2571 12	20-12
4004 2582 01	16-9
4004 2582 01	20-3
4004 3001 02	50-6
4004 3003 02	50-12
4004 3004 01	50-15
4004 3005 01	50-8
4004 3006 03	50-17
4004 3008 01	49-16
4004 3011 01	32-22
4004 3012 01	32-23
4004 3023 01	49-28
4004 3024 01	49-11
4004 3029 01	32-3
4004 3030 01	49-33
4004 3031 01	49-25
4004 3032 01	49-27
4004 3033 01	49-14
4004 3038 01	49-15
4004 3040 02	49-10
4004 3042 01	49-30
4004 3051 02	49-24
4004 3052 01	32-20
4004 3503 02	45-4
4004 3504 02	45-5
4004 3512 02	31-11
4004 3516 02	31-13
4004 3521 02	42-14
4004 3524 04	44-24
4004 3525 01	35-10
4004 3538 01	35-9

Parts No.	Page No.
4004 3547 01	42-20
4004 3549 03	44-13
4004 3581 01	42-5
4004 3582 01	42-24
4004 4527 02	36-20
4004 4532 01	16-6
4004 4533 01	16-5
4004 4544 02	34-10
4004 4546 02	34-7
4004 4553 01	34-12
4004 4555 02	34-24
4004 4710 02	43-18
4004 4711 02	43-22
4004 4722 02	43-8
4004 4723 01	43-5
4004 4724 02	43-17
4004 5282 01	39-11
4004 5283 01	39-2
4004 5287 01	39-12
4004 5337 01	14-26
4004 5338 01	14-25
4004 5339 01	14-23
4004 5339 01	41-26
4004 5353 02	14-6
4004 5354 01	14-4
4004 5356 01	14-7
4004 5601 02	34-1
4004 5604 01	34-6
4004 5605 01	34-5
4004 5607 02	34-3
4004 5609 01	34-17
4004 5610 01	34-16
4004 5611 01	34-19
4004 5613 01	34-18
4004 5903 01	41-14
4004 5905 02	46-17
4004 5909 02	46-15
4004 5911 02	46-19
4004 5918 02	41-7
4004 5928 12	46-25

Parts No.	Page No.
4004 5933 01	41-17
4004 5935 01	41-18
4004 5948 01	41-27
4004 5950 01	46-16
4004 5974 02	46-20
4004 5975 01	41-3
4004 5979 01	40-6
4004 5987 01	46-12
4004 5992 02	41-6
4004 6831 01	32-9
4004 6832 01	32-15
4004 6854 01	37-12
4004 6854 01	38-6
4004 7318 01	44-22
4004 7324 01	49-36
4004 7502 01	58-27
4004 7503 12	58-28
4005 0201 01	5-2
4005 0203 01	5-20
4005 1464 01	5-3
4011 0111 01	30-13
4011 0111 01	32-18
4011 3011 01	49-6
4011 3012 01	30-14
4021 3012 01	50-7
4021 3036 01	49-29
4025 0221 01	45-18
4025 0225 01	44-7
4025 0901 01	44-19
4025 1011 01	1-26
4025 1012 01	10-22
4025 1018 01	1-11
4025 1019 01	10-19
4025 1702 03	38-16
4025 1703 01	38-21
4025 1716 01	38-18
4025 1720 02	38-24
4025 1812 01	37-27
4025 1813 02	38-20
4025 1840 01	37-9

Parts No.	Page No.
4025 1841 01	37-11
4025 2147 01	37-25
4025 2150 01	37-26
4025 2151 01	38-10
4025 2152 01	38-17
4025 2171 01	38-9
4025 2172 02	38-7
4025 2175 01	38-2
4025 2221 01	37-17
4025 2228 01	37-19
4025 2250 01	37-21
4025 2272 01	37-16
4025 2273 01	37-15
4025 2274 01	37-20
4025 2285 02	1-19
4025 2285 02	3-17
4025 2287 01	48-2
4025 2294 01	15-2
4025 2294 01	48-23
4025 2422 01	39-1
4025 2458 01	15-6
4025 2465 01	15-29
4025 2466 01	15-8
4025 2468 01	15-10
4025 3502 01	45-10
4025 3522 02	43-14
4025 3523 01	44-16
4025 3527 01	45-2
4025 3533 02	33-6
4025 3534 01	42-4
4025 3548 01	44-2
4025 3551 01	44-3
4025 3556 01	33-22
4025 3558 01	33-5
4025 3567 01	44-26
4025 3568 01	44-27
4025 3572 01	45-3
4025 3575 01	44-25
4025 3577 02	32-1
4025 3609 01	45-12

Parts No.	Page No.
4025 3610 01	42-25
4025 3612 01	44-18
4025 3616 01	42-12
4025 3621 01	45-8
4025 3622 01	45-9
4025 3623 01	45-14
4025 3625 01	45-16
4025 3626 01	45-19
4025 3627 01	45-17
4025 3631 02	45-7
4025 3642 01	33-17
4025 3674 02	33-4
4025 3676 01	33-7
4025 3677 01	43-15
4025 3679 01	43-11
4025 3680 01	43-12
4025 4709 02	43-2
4025 4714 01	43-1
4025 4717 02	43-9
4025 4719 02	43-21
4025 4720 01	43-23
4025 4721 01	44-23
4025 4725 01	43-10
4025 4900 01	44-10
4025 4906 01	44-9
4025 4907 01	44-5
4025 4908 01	44-8
4025 4909 01	43-4
4025 4910 01	44-6
4025 5290 01	37-3
4025 5294 01	37-4
4025 5307 01	14-28
4025 5331 01	14-21
4025 5332 01	14-20
4025 5333 01	14-27
4025 5335 01	14-24
4025 5351 01	14-11
4025 5352 01	14-5
4025 5362 01	14-3
4025 5363 01	14-1

Parts No.	Page No.
4025 5365 01	14-2
4025 5412 01	13-4
4025 5417 01	13-12
4025 5420 01	13-10
4025 5421 01	13-8
4025 5422 01	13-6
4025 5441 02	14-8
4025 5442 02	13-21
4025 5614 01	34-15
4025 5901 01	41-16
4025 5904 01	46-21
4025 5915 01	46-13
4025 5939 01	41-19
4025 5940 01	41-8
4025 5962 01	41-21
4025 5984 01	41-15
4025 6805 01	9-6
4025 6805 01	9-21
4025 6814 01	10-2
4025 7323 01	44-21
4025 7901 01	58-31
4030 0151 01	28-10
4030 0216 03	23-17
4030 1034 02	59-3
4030 1041 01	3-2
4030 1041 01	59-4
4030 2080 01	29-21
4030 3002 02	26-12
4030 3003 01	26-16
4030 3005 01	26-11
4030 3008 01	26-17
4030 3010 02	26-5
4030 3011 02	26-22
4030 3012 01	26-23
4030 3013 01	28-13
4030 3014 01	28-15
4030 3016 12	26-4
4030 3017 02	28-14
4030 3020 01	26-19
4030 3025 02	28-6



Parts No.	Page No.	Parts No.	Page No.	Parts No.	Page No.	Parts No.	Page No.	Parts No.	Page No.
4030 3030 01	26-20	4030 3226 01	51-10	4030 3459 02	23-10	4036 0213 01	36-19	4036 1387 02	2-12
4030 3034 01	26-10	4030 3227 01	52-10	4030 3460 02	23-18	4036 0215 01	32-8	4036 1388 01	2-10
4030 3036 01	26-14	4030 3228 01	52-9	4030 3461 01	23-8	4036 0217 01	19-8	4036 1390 01	2-9
4030 3037 01	28-5	4030 3229 02	51-1	4030 3464 01	25-7	4036 0218 01	46-27	4036 1391 03	3-12
4030 3039 01	28-16	4030 3401 13	24-24	4030 3465 01	25-10	4036 0235 01	29-14	4036 1392 02	3-6
4030 3046 03	30-11	4030 3402 01	24-28	4030 3466 02	23-1	4036 0236 01	29-27	4036 1394 02	3-18
4030 3047 02	30-23	4030 3403 01	24-29	4030 3467 01	25-20	4036 0238 02	26-26	4036 1395 07	3-1
4030 3048 02	30-8	4030 3404 01	24-22	4030 3472 01	23-31	4036 0239 01	27-15	4036 1396 03	3-14
4030 3049 01	30-9	4030 3408 03	23-12	4030 3473 02	23-16	4036 0240 01	24-32	4036 1397 01	3-23
4030 3077 01	28-9	4030 3409 14	24-4	4030 3474 01	24-20	4036 0563 01	38-1	4036 1399 03	2-5
4030 3078 01	28-11	4030 3410 03	23-23	4030 3475 01	24-21	4036 0564 01	38-1	4036 1402 02	3-3
4030 3079 01	28-12	4030 3411 03	23-27	4030 3476 01	24-5	4036 1003 03	1-4	4036 1403 01	7-1
4030 3081 01	30-5	4030 3412 01	23-19	4030 3477 01	24-7	4036 1005 03	10-12	4036 1404 03	3-11
4030 3083 01	30-7	4030 3414 01	23-4	4030 3478 02	25-21	4036 1010 02	10-11	4036 1408 01	59-5
4030 3091 01	30-22	4030 3415 01	23-5	4030 3479 01	25-2	4036 1011 01	10-13	4036 1410 01	3-9
4030 3095 01	26-13	4030 3416 01	25-6	4030 3481 01	24-16	4036 1013 01	10-21	4036 1425 01	5-15
4030 3115 01	27-23	4030 3417 01	25-4	4030 3484 01	24-6	4036 1015 01	10-15	4036 1451 02	5-6
4030 3116 01	27-8	4030 3422 01	25-24	4030 3486 01	23-26	4036 1024 02	1-3	4036 1453 01	5-4
4030 3122 01	27-4	4030 3423 03	23-9	4030 3487 01	23-28	4036 1025 02	11-4	4036 1454 01	5-1
4030 3125 01	28-4	4030 3424 01	24-13	4030 3489 01	24-19	4036 1026 01	1-13	4036 1500 02	7-7
4030 3129 03	28-3	4030 3425 01	24-10	4030 3492 01	24-25	4036 1028 03	1-1	4036 1501 03	7-11
4030 3201 03	52-17	4030 3427 01	24-23	4030 3495 01	25-14	4036 1032 01	14-14	4036 1502 02	7-9
4030 3202 02	51-4	4030 3428 01	24-14	4030 3754 01	24-3	4036 1033 01	1-20	4036 1503 02	7-3
4030 3203 01	51-9	4030 3429 02	25-3	4030 6814 03	23-29	4036 1034 02	1-5	4036 1504 02	7-8
4030 3205 01	52-27	4030 3430 01	24-11	4030 6818 01	53-1	4036 1035 01	1-7	4036 1505 02	7-4
4030 3206 01	52-28	4030 3432 04	24-12	4030 7301 02	49-21	4036 1039 01	10-16	4036 1506 01	7-5
4030 3207 01	52-23	4030 3434 01	25-13	4030 7301 02	51-6	4036 1040 01	10-17	4036 1509 01	7-6
4030 3208 02	30-10	4030 3435 01	23-15	4030 7303 02	51-5	4036 1042 01	10-14	4036 1582 01	6-1
4030 3211 02	52-16	4030 3436 01	23-30	4030 7305 01	23-11	4036 1048 01	1-25	4036 1611 01	3-21
4030 3212 01	52-1	4030 3437 01	23-14	4030 7309 02	23-11	4036 1051 01	11-13	4036 1620 01	3-7
4030 3214 01	52-5	4030 3438 01	24-18	4030 7312 01	59-2	4036 1052 03	11-1	4036 1630 01	4-11
4030 3215 01	52-6	4030 3443 02	24-30	4030 7500 01	1-10	4036 1054 01	11-14	4036 1631 01	4-8
4030 3216 01	52-20	4030 3444 01	25-8	4034 0151 01	24-27	4036 1328 01	4-9	4036 1632 02	4-7
4030 3217 01	52-8	4030 3445 01	25-9	4034 0151 01	50-10	4036 1366 01	6-2	4036 1633 01	6-11
4030 3218 01	52-21	4030 3446 01	23-6	4036 0105 02	37-8	4036 1374 02	6-10	4036 1701 01	38-12
4030 3221 01	51-2	4030 3447 01	24-2	4036 0132 02	30-21	4036 1380 02	2-7	4036 1704 01	38-4
4030 3222 03	51-13	4030 3448 01	24-17	4036 0153 01	19-20	4036 1381 03	2-17	4036 1705 01	38-22
4030 3223 02	51-12	4030 3455 02	23-20	4036 0207 01	18-4	4036 1383 02	2-14	4036 1720 01	4-12
4030 3224 01	30-4	4030 3456 01	24-9	4036 0208 01	17-23	4036 1385 01	2-6	4036 1814 01	38-23
4030 3224 01	51-3	4030 3457 03	24-15	4036 0209 01	19-23	4036 1386 02	2-15	4036 1815 01	38-3

Parts No.	Page No.
4036 1821 01	12-4
4036 1837 01	12-18
4036 1845 02	12-24
4036 1846 01	12-26
4036 1847 02	12-25
4036 2007 01	12-20
4036 2008 01	31-6
4036 2009 01	31-1
4036 2023 01	8-7
4036 2024 01	10-7
4036 2070 01	31-4
4036 2071 01	31-18
4036 2101 02	10-8
4036 2102 02	32-2
4036 2146 02	15-17
4036 2176 01	38-11
4036 2204 04	8-3
4036 2210 01	16-23
4036 2211 03	9-1
4036 2212 02	11-2
4036 2214 02	11-12
4036 2215 01	16-16
4036 2216 02	9-4
4036 2223 01	39-14
4036 2224 02	37-1
4036 2226 01	37-22
4036 2237 01	17-43
4036 2238 01	16-20
4036 2241 01	20-18
4036 2245 01	11-10
4036 2252 01	20-15
4036 2257 01	10-4
4036 2257 01	14-16
4036 2258 01	20-20
4036 2301 02	35-1
4036 2303 01	35-2
4036 2304 01	35-3
4036 2305 01	35-13
4036 2306 01	35-14
4036 2307 01	35-16

Parts No.	Page No.
4036 2308 01	35-15
4036 2309 01	35-19
4036 2311 01	12-23
4036 2311 01	35-5
4036 2311 01	36-13
4036 2404 01	39-9
4036 2405 01	39-10
4036 2406 01	39-4
4036 2424 01	39-3
4036 2425 01	37-28
4036 2425 01	39-5
4036 2426 01	37-31
4036 2459 02	15-1
4036 2480 01	16-2
4036 2481 01	16-1
4036 2482 01	16-24
4036 2485 01	15-26
4036 2487 01	15-20
4036 2487 01	48-24
4036 2511 01	17-36
4036 2512 01	17-8
4036 2513 01	17-7
4036 2514 01	17-15
4036 2515 01	17-12
4036 2517 01	17-29
4036 2519 01	17-34
4036 2520 01	17-22
4036 2521 01	17-31
4036 2531 01	17-24
4036 2537 01	17-28
4036 2538 01	17-10
4036 2541 01	17-5
4036 2543 01	17-27
4036 2544 01	17-26
4036 2552 01	20-1
4036 2553 01	20-4
4036 2555 01	19-10
4036 2557 01	20-2
4036 2559 01	19-12
4036 2560 01	19-3

Parts No.	Page No.
4036 2561 01	19-1
4036 2563 01	19-5
4036 2564 01	19-9
4036 2565 01	19-6
4036 2567 01	19-2
4036 2574 01	20-10
4036 2577 01	20-8
4036 2581 01	20-6
4036 2583 01	20-5
4036 2585 01	19-7
4036 2586 01	20-22
4036 2595 01	16-13
4036 2596 01	16-8
4036 2597 01	16-10
4036 2598 01	16-11
4036 2599 01	16-12
4036 2751 01	18-7
4036 2752 01	17-30
4036 2752 01	18-12
4036 2753 01	18-16
4036 2754 02	17-2
4036 2754 02	18-1
4036 2757 01	18-17
4036 2758 01	18-3
4036 2760 01	18-14
4036 2761 01	18-13
4036 2762 01	17-39
4036 2764 01	17-32
4036 2766 02	17-16
4036 2766 02	18-6
4036 2767 01	17-6
4036 2767 01	18-2
4036 2768 01	17-37
4036 2768 01	18-15
4036 2769 01	17-13
4036 2769 01	18-5
4036 2772 02	17-41
4036 2774 01	17-20
4036 2774 01	18-9
4036 2775 01	17-19

Parts No.	Page No.
4036 2775 01	18-10
4036 3008 01	49-4
4036 3014 01	50-21
4036 3016 01	32-4
4036 3018 01	50-20
4036 3019 01	49-8
4036 3020 02	49-19
4036 3021 02	49-18
4036 3022 01	49-1
4036 3025 01	49-22
4036 3025 01	51-7
4036 3028 01	49-37
4036 3040 01	50-19
4036 3063 01	50-1
4036 3071 01	12-1
4036 3075 01	5-25
4036 3075 01	12-2
4036 3086 01	49-5
4036 3505 03	42-1
4036 3506 01	44-17
4036 3507 04	33-9
4036 3511 01	31-10
4036 3517 01	20-9
4036 3518 02	31-8
4036 3519 01	42-11
4036 3520 01	42-23
4036 3526 01	35-8
4036 3528 01	42-17
4036 3530 02	31-9
4036 3531 01	33-3
4036 3540 01	33-13
4036 3542 01	42-10
4036 3550 01	42-26
4036 3555 01	33-1
4036 3557 01	33-21
4036 3570 03	44-1
4036 3576 01	32-25
4036 3583 01	31-7
4036 3587 01	33-10
4036 3590 02	42-13

Parts No.	Page No.
4036 3597 01	42-2
4036 3608 01	45-11
4036 3630 01	43-20
4036 3641 02	33-16
4036 3643 01	33-2
4036 3645 01	33-19
4036 3649 01	33-20
4036 3653 01	42-9
4036 3654 02	32-6
4036 3655 01	32-7
4036 3656 01	31-5
4036 3658 01	31-15
4036 3659 01	42-3
4036 3661 02	31-23
4036 3662 02	31-25
4036 3663 02	31-19
4036 3664 01	31-22
4036 3665 01	42-16
4036 3666 01	42-15
4036 3667 02	31-2
4036 3668 01	31-21
4036 3671 01	33-11
4036 3672 01	34-23
4036 3673 01	33-8
4036 3675 01	43-13
4036 3681 01	31-17
4036 3682 01	31-12
4036 3683 01	42-7
4036 3684 01	44-12
4036 3801 02	29-26
4036 3802 01	29-5
4036 3803 02	29-1
4036 3805 02	29-19
4036 3806 03	29-23
4036 3807 01	29-20
4036 3808 01	29-6
4036 3809 01	29-25
4036 3810 01	29-30
4036 3811 01	29-24
4036 3814 01	29-15

Parts No.	Page No.	Parts No.	Page No.	Parts No.	Page No.	Parts No.	Page No.	Parts No.	Page No.
4036 3815 01	30-15	4036 4560 01	35-12	4036 5902 02	40-4	4036 5990 01	46-22	4036 7315 01	13-14
4036 3816 12	26-7	4036 4617 03	36-11	4036 5906 02	46-24	4036 5995 02	41-11	4036 7316 01	13-13
4036 3818 01	27-12	4036 4618 02	36-12	4036 5907 01	46-1	4036 6062 01	38-8	4036 7317 02	13-11
4036 3819 12	27-11	4036 4621 01	36-10	4036 5908 01	47-5	4036 6805 03	53-2	4036 7318 01	13-9
4036 3820 12	28-2	4036 4622 01	36-8	4036 5910 01	46-23	4036 6809 02	42-22	4036 7319 01	13-7
4036 3821 01	28-1	4036 4626 01	36-5	4036 5912 01	46-6	4036 6810 02	53-3	4036 7330 01	1-29
4036 3822 01	27-1	4036 4635 01	36-9	4036 5913 01	46-5	4036 6811 01	35-22	4036 7331 01	40-3
4036 3823 01	27-6	4036 4636 01	36-6	4036 5914 01	46-7	4036 6812 01	35-24	4036 7340 02	1-18
4036 3825 01	27-24	4036 4679 02	36-4	4036 5916 02	40-2	4036 6813 01	35-26	4036 7341 01	23-25
4036 3827 01	27-2	4036 4680 15	36-14	4036 5917 03	41-9	4036 6814 01	35-27	4036 7342 01	3-10
4036 3828 01	29-16	4036 4692 01	36-7	4036 5920 01	41-31	4036 6815 02	35-23	4036 7343 01	3-10
4036 3830 01	26-1	4036 4712 01	43-7	4036 5921 01	41-5	4036 6816 02	35-25	4037 0105 01	37-8
4036 3831 01	27-19	4036 4713 01	43-6	4036 5925 01	41-23	4036 6818 01	35-28	4037 0113 01	6-6
4036 3832 01	27-7	4036 4845 12	36-16	4036 5926 01	41-4	4036 6820 01	35-7	4037 0115 02	4-4
4036 3833 01	27-5	4036 4846 01	36-17	4036 5927 01	41-28	4036 6821 01	35-20	4037 0130 04	48-17
4036 3834 01	27-22	4036 4847 01	36-18	4036 5929 01	41-2	4036 6822 01	35-21	4037 0131 04	48-18
4036 3835 01	26-28	4036 4849 12	36-15	4036 5931 01	41-30	4036 6824 02	26-25	4037 0132 04	48-20
4036 3837 02	27-10	4036 4901 01	12-22	4036 5932 02	41-1	4036 6825 02	30-20	4037 0133 04	48-41
4036 3838 01	28-8	4036 4902 01	35-17	4036 5937 01	46-26	4036 6826 01	30-18	4037 0134 04	48-12
4036 3839 01	27-17	4036 4903 01	35-18	4036 5942 01	41-13	4036 6827 02	9-5	4037 0560 01	37-34
4036 3841 02	27-18	4036 4904 01	34-8	4036 5943 02	40-1	4036 6828 01	35-6	4037 0561 01	37-34
4036 3843 01	29-9	4036 4909 01	34-25	4036 5944 02	47-1	4036 6829 01	30-19	4037 0561 01	37-34
4036 3845 01	29-22	4036 4911 01	43-3	4036 5945 01	46-14	4036 6831 01	48-36	4037 0751 01	58-29
4036 3846 01	28-7	4036 5288 01	37-32	4036 5958 01	41-25	4036 6835 01	37-7	4037 0751 01	58-29
4036 3849 01	29-13	4036 5291 01	37-30	4036 5959 01	41-24	4036 6857 01	6-12	4037 0752 00	3-19
4036 3853 01	25-18	4036 5301 03	13-20	4036 5961 01	41-22	4036 6858 01	6-8	4037 0754 00	6-19
4036 3855 01	25-15	4036 5302 01	14-29	4036 5966 01	1-15	4036 6859 01	5-24	4037 0755 00	5-9
4036 3856 02	23-32	4036 5325 02	13-15	4036 5966 01	34-11	4036 6860 01	4-18	4037 0756 00	49-38
4036 3857 01	24-1	4036 5347 01	13-16	4036 5966 01	40-8	4036 6861 01	48-9	4037 0758 00	13-22
4036 3860 02	23-13	4036 5348 01	13-17	4036 5966 01	41-12	4036 6862 01	2-11	4037 0759 00	13-22
4036 3861 01	26-27	4036 5349 02	13-18	4036 5968 02	46-2	4036 6862 01	6-3	4037 0760 00	13-22
4036 4510 01	36-1	4036 5411 01	13-3	4036 5969 02	46-3	4036 6870 01	48-22	4037 0761 00	42-27
4036 4515 01	36-3	4036 5413 01	13-1	4036 5971 01	46-9	4036 7302 01	1-2	4037 0763 00	37-34
4036 4541 01	34-14	4036 5414 01	13-19	4036 5972 01	40-5	4036 7303 01	10-25	4037 0764 00	37-34
4036 4542 01	34-20	4036 5419 01	13-2	4036 5973 01	47-3	4036 7304 01	42-8	4037 0764 00	37-34
4036 4543 01	34-9	4036 5606 01	34-4	4036 5976 01	46-18	4036 7307 01	49-20	4037 0765 00	38-1
4036 4545 01	34-26	4036 5612 01	34-2	4036 5977 01	46-4	4036 7311 01	23-24	4037 0766 00	38-1
4036 4549 01	35-11	4036 5615 01	34-22	4036 5985 01	47-7	4036 7312 01	23-24	4037 0767 00	44-4
4036 4550 01	34-13	4036 5785 01	42-19	4036 5987 01	47-6	4036 7313 01	49-32	4037 0768 00	20-21
4036 4551 01	12-21	4036 5900 02	46-11	4036 5988 01	47-4	4036 7314 01	49-35	4037 0901 01	16-15

Parts No.	Page No.
4037 0901 01	37-13
4037 0902 01	26-2
4037 0903 01	4-10
4037 0903 01	14-9
4037 0903 01	17-40
4037 0903 01	18-20
4037 0903 01	20-11
4037 0903 01	21-10
4037 0903 01	31-3
4037 0903 01	44-11
4037 0904 01	32-21
4037 0905 01	46-8
4037 0906 01	23-2
4037 0906 01	24-31
4037 0906 01	25-1
4037 0906 01	26-8
4037 0906 01	27-20
4037 0906 01	30-6
4037 1001 01	1-12
4037 1002 04	1-6
4037 1004 04	1-8
4037 1006 01	1-27
4037 1007 02	1-23
4037 1008 02	1-28
4037 1009 03	1-21
4037 1027 02	1-17
4037 1393 01	3-4
4037 1398 01	2-4
4037 1405 02	3-16
4037 1406 02	7-10
4037 1590 01	6-14
4037 1721 02	4-13
4037 2010 01	31-20
4037 2201 03	48-15
4037 2202 03	48-40
4037 2205 01	9-11
4037 2206 02	48-28
4037 2207 03	48-1
4037 2208 02	9-16
4037 2217 02	48-10

Parts No.	Page No.
4037 2219 02	48-43
4037 2220 02	48-7
4037 2231 02	9-18
4037 2234 01	48-25
4037 2239 01	9-15
4037 2240 01	48-8
4037 2242 01	48-4
4037 2244 01	48-29
4037 2246 02	48-34
4037 2247 01	48-6
4037 2256 01	9-12
4037 2260 02	48-16
4037 2283 01	48-19
4037 2452 02	15-3
4037 2453 03	15-9
4037 2454 03	8-2
4037 2463 02	15-5
4037 2483 04	15-23
4037 2484 01	15-22
4037 2486 01	15-19
4037 2488 03	15-27
4037 2489 02	15-28
4037 2490 02	15-12
4037 2491 01	15-11
4037 2492 01	15-25
4037 2493 02	15-13
4037 2494 01	15-24
4037 2542 01	17-17
4037 3072 01	12-8
4037 3204 01	52-15
4037 3210 01	49-7
4037 3213 01	52-11
4037 3223 01	49-28
4037 3226 01	49-26
4037 3227 01	49-34
4037 3501 01	45-13
4037 3678 01	43-16
4037 3685 01	45-21
4037 3750 01	21-22
4037 6051 03	2-1

Parts No.	Page No.
4037 6052 03	2-1
4037 6053 03	2-1
4037 6058 01	2-1
4037 6059 01	2-1
4037 6061 01	38-8
4037 6076 01	48-26
4037 6081 01	48-27
4037 6095 01	48-21
4037 6201 01	16-22
4037 6202 01	16-19
4037 6211 02	9-2
4037 6212 02	9-2
4037 6751 01	9-9
4037 6776 01	48-5
4037 6777 01	48-42
4037 6778 02	48-44
4037 6779 01	48-39
4037 6801 03	54-1
4037 6802 04	55-1
4037 6803 01	56-1
4037 6804 02	56-2
4037 6805 01	56-1
4037 6809 01	54-1
4037 6810 01	56-2
4037 6812 01	15-30
4037 6813 01	33-14
4037 6814 02	57-1
4037 6823 01	37-10
4037 6831 01	48-31
4037 6852 03	57-3
4037 6853 01	57-4
4037 6854 01	6-18
4037 6899 01	23-21
4037 7305 01	42-21
4037 7306 12	49-17
4037 7310 01	59-2
4037 7320 01	47-2
4037 7321 01	1-9
4037 7322 01	1-9
4037 7403 01	3-15

Parts No.	Page No.
4037 7406 01	1-24
4037 7407 01	3-15
4037 7803 01	48-37
4037 7804 01	48-37
4040 0156 01	51-14
4040 7304 01	51-8
4049 111	34-27
4049 212	36-22
4049 311	36-21
4049 411	45-22
4049 521	31-27
4049 522	31-27
4049 523	31-27
4049 524	31-27
4049 611	44-28
4053 0151 01	15-4
4110 2311 01	48-3
4120 4614 01	15-7
4128 3823 01	52-14
4131 2571 01	19-4
4131 2575 01	19-22
4131 2576 01	19-17
4131 2577 01	19-16
4131 2578 01	19-21
4131 2579 03	19-18
4131 2590 01	19-14
4131 2591 01	19-15
4131 3001 01	25-12
4131 3003 01	26-6
4131 3053 02	24-26
4131 4623 03	23-22
4134 3106 01	49-3
4134 3579 03	10-18
4163 5293 01	27-9
4163 5293 01	49-23
4348 0202 01	30-2
4348 2016 01	29-2
4348 2021 01	29-12
4348 2037 02	29-7
4348 2038 02	29-8

Parts No.	Page No.
4348 2040 01	29-28
4348 2041 02	29-18
4348 2042 01	29-4
4348 2044 01	29-17
4348 3011 03	27-13
4348 3028 01	27-21
4348 3029 01	26-29
4348 3030 01	30-3
4348 3031 01	27-16
4348 3032 01	25-16
4348 3047 01	26-24
4348 3048 01	27-14
4348 3049 01	26-3
4348 3071 01	27-3
4425 3013 01	26-9
4425 3016 01	26-15
4497 3106 03	22-2
4497 3109 02	22-21
4497 3114 01	22-13
4497 3116 01	22-20
4498 3469 01	51-11
4498 3825 01	52-13
4498 3826 01	52-12
4498 3834 01	52-19
4535 0201 01	21-23
4535 3105 01	22-1
4535 3702 01	22-22
4535 3703 02	22-12
4535 3704 02	21-20
4535 3705 03	21-1
4535 3706 01	22-18
4535 3707 01	22-19
4535 3709 01	59-6
4535 3710 01	22-10
4535 3711 01	22-6
4535 3724 01	22-17
4535 3729 01	22-7
4535 3731 01	22-15
4535 3732 01	21-11
4535 3752 01	21-2

Parts No.	Page No.
4537 0901 01	23-2
4537 0901 01	24-31
4537 0901 01	25-1
4537 0901 01	26-8
4537 0901 01	27-20
4537 0901 01	30-6
4581 1316 01	58-33
4581 1318 01	3-8
4581 1320 01	4-20
4581 1379 01	2-8
4581 1382 01	2-16
4581 1389 01	2-13
4581 1421 01	5-19
4581 1427 01	5-13
4581 1428 01	5-21
4581 1429 01	5-22
4581 1452 01	5-7
4581 1455 01	5-8
4581 1457 01	4-3
4581 1579 01	6-4
4581 1605 03	3-22
4581 1610 01	3-20
4581 1621 02	3-13
4581 1625 01	4-6
4581 1627 01	4-5
4581 1640 02	5-18
4581 2269 02	6-13
4581 2269 02	48-11
4581 3806 01	5-23
4581 7901 02	58-32
4643 4605 01	42-6
4657 0101 01	21-19
4657 0202 01	22-9
4657 3708 02	22-16
4657 3709 01	22-5
4657 3714 01	22-8
4657 3721 01	21-16
4657 3722 01	21-5
4657 3723 02	21-24
4657 3730 02	21-6

Parts No.	Page No.
4657 3734 01	21-7
4657 3735 01	22-14
4657 3736 01	22-3
4657 3743 01	21-9
4657 3745 01	21-3
4657 3746 01	21-4
4657 3747 01	21-8
4657 3749 01	21-15
4657 3750 01	21-21
4657 6801 02	57-2
4658 3012 01	52-7
4658 3035 02	50-11
4658 3040 01	50-13
4658 3047 01	50-14
4658 3048 01	52-2
4658 3049 01	52-4
4658 3140 02	29-11
4658 3517 01	25-22
4687 3281 01	24-8
9312 1200 31	30-12
9313 1000 61	9-20
9313 1000 72	15-21
9313 1300 12	15-32
9313 1300 41	1-16
9313 1300 41	4-19
9313 1300 41	8-1
9313 1300 41	40-7
9313 1400 31	48-30
9313 1400 41	15-31
9313 1910 61	42-18
9314 1001 01	21-14
9314 1100 71	16-3
9314 1100 81	4-1
9314 1300 21	14-12
9314 1300 31	45-1
9314 1300 61	30-1
9314 2300 21	18-19
9314 2300 31	16-14
9314 2300 31	17-44
9314 2300 31	19-26

Parts No.	Page No.
9314 2300 41	18-18
9314 2400 21	17-42
9321 2400 51	19-19
9321 2400 71	25-25
9322 1200 31	25-19
9322 1300 31	17-25
9322 1300 41	17-33
9322 1400 11	45-20
9325 4400 21	5-11
9326 1000 61	48-14
9326 1001 11	2-2
9326 1001 11	6-7
9326 1001 11	6-9
9326 1200 21	37-6
9326 1200 61	4-16
9326 1200 61	6-5
9326 1200 61	23-7
9326 1200 61	48-38
9326 1410 31	21-12
9326 1810 21	4-17
9326 1810 21	6-15
9326 1810 21	9-13
9326 1810 21	48-35
9331 2200 21	10-1
9331 2200 21	14-18
9331 2200 21	20-16
9332 1710 41	11-11
9332 1910 21	37-14
9334 2610 11	3-5
9335 1400 81	6-16
9335 1400 81	6-17
9335 1400 81	6-17
9335 1401 01	14-10
9335 1401 21	13-5
9351 3300 11	5-10
9372 1300 12	33-12
9372 5400 11	33-15
9381 4101 31	59-8
9381 4300 31	59-8
9381 4300 41	59-8

Parts No.	Page No.
9381 4300 91	59-8
9381 4400 11	59-8
9383 2510 21	9-14
9383 5000 11	9-17
9384 1000 51	58-1
9384 1100 21	58-13
9384 1100 31	58-26
9384 1100 91	58-2
9384 1110 61	58-7
9384 1211 01	58-6
9384 1300 51	58-16
9384 1300 61	58-17
9384 1300 71	58-3
9384 1310 11	58-9
9384 1310 81	58-10
9384 1311 01	58-8
9384 1311 11	58-25
9384 1521 51	58-24
9384 1610 11	48-32
9384 1621 21	16-7
9384 1621 21	17-35
9384 1621 21	19-24
9384 1621 21	21-18
9384 1621 21	30-16
9384 1700 24	59-7
9384 1811 01	58-18
9384 1820 31	58-11
9384 1900 55	16-21
9384 1900 56	21-17
9384 1900 57	4-15
9384 1921 01	58-4
9384 1921 11	58-12
9384 1921 21	58-5
9384 2010 21	58-21
9384 2910 21	58-19
9384 2910 31	58-20
9450 1806 01	9-3
9454 4076 02	33-18

# EXTERNAL PARTS

改訂版 REVISED EDITION	日付 DATE
▲	MAY 2005

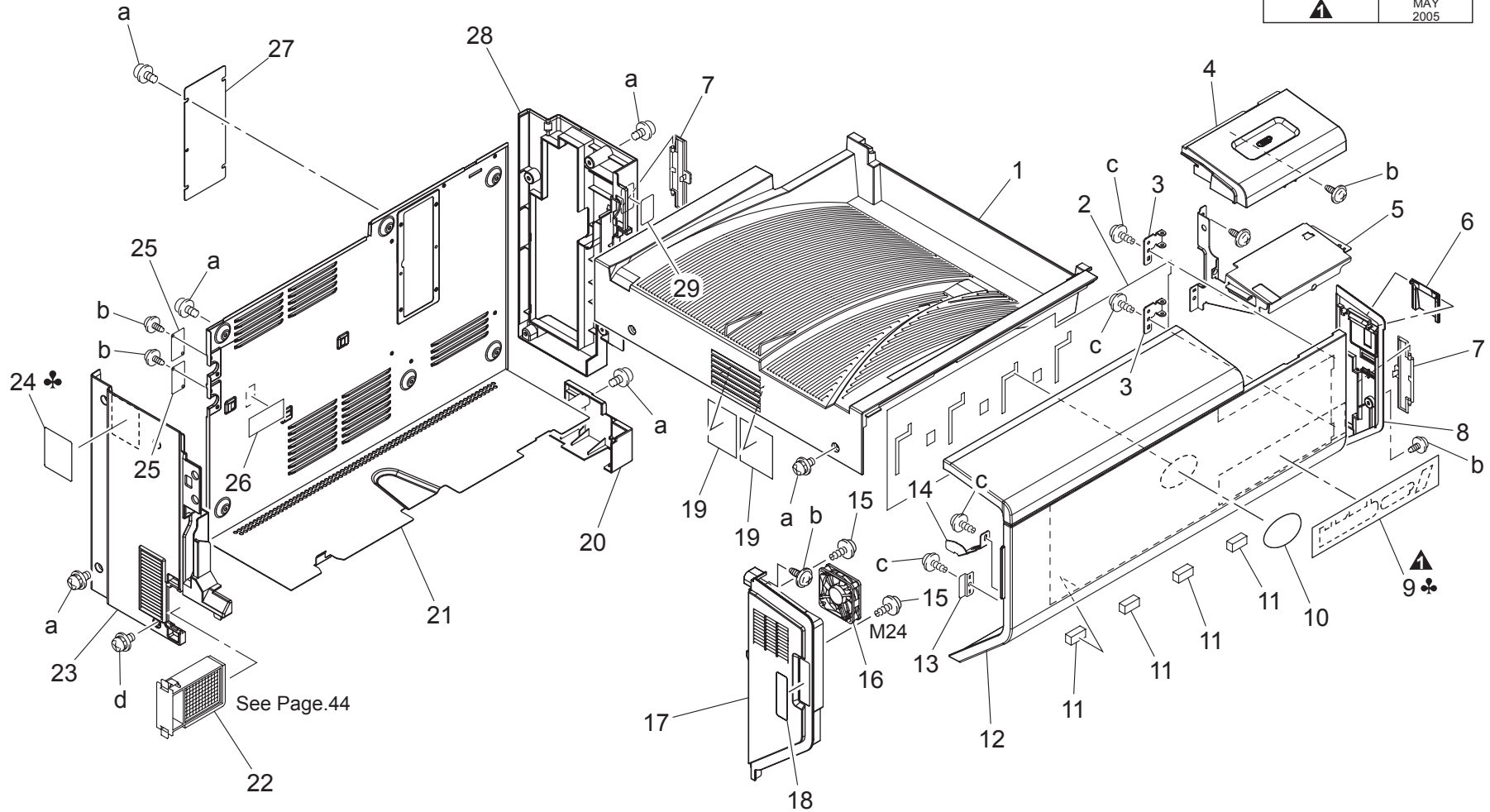

EXTERNAL PARTS

Key	Part No.	Description	Destinations	Class	QTY	Standard parts
1	4036 1028 03	TOP COVER		C	1	a-9646 0308 14 b-9735 0308 14 c-9739 0408 14 d-9646 0408 14
2	4036 7302 01	LABEL TC.IC CLEAN		C	1	
3	4036 1024 02	HINGE		C	2	
4	4036 1003 03	UPPER COVER		C	1	
5	4036 1034 02	BRACKET		D	1	
6	4037 1002 04	COVER		C	1	
7	4036 1035 01	LID		C	2	
8	4037 1004 04	RIGHT COVER F		C	1	
9	4037 7321 01	LABEL bizhub C450	(bizhub C450)	D	1	
9	4037 7322 01	LABEL bizhub C351	(bizhub C351)	D	1	
10	4030 7500 01	LABEL LOGO MARK		C	1	
11	4025 1018 01	SEAL		C	4	
12	4037 1001 01	FRONT COVER		D	1	
13	4036 1026 01	SUCTION PLATE		D	1	
14	4004 1031 03	GUIDE PLATE		C	1	
15	4036 5966 01	SCREW		C	2	
16	9313 1300 41	FAN MOTOR		C	1	
17	4037 1027 02	LEFT COVER F		C	1	
18	4036 7340 02	LABEL TONER		C	1	
19	4025 2285 02	FILTER		C	2	
20	4036 1033 01	RIGHT COVER LOWER		C	1	
21	4037 1009 03	REAR COVER		D	1	
22	1483 0757 00	OZONE FILTER		C	1	
23	4037 1007 02	LEFT COVER REAR		C	1	
24	4037 7406 01	LABEL EARTH CAUTION	C,D,F2,G1,I,K	D	1	
25	4036 1048 01	COVER		C	2	
26	4025 1011 01	FILM		D	1	
27	4037 1006 01	COVER		D	1	
28	4037 1008 02	RIGHT COVER REAR		C	1	
29	4036 7330 01	LABEL M3		C	1	

CONTROL PANEL

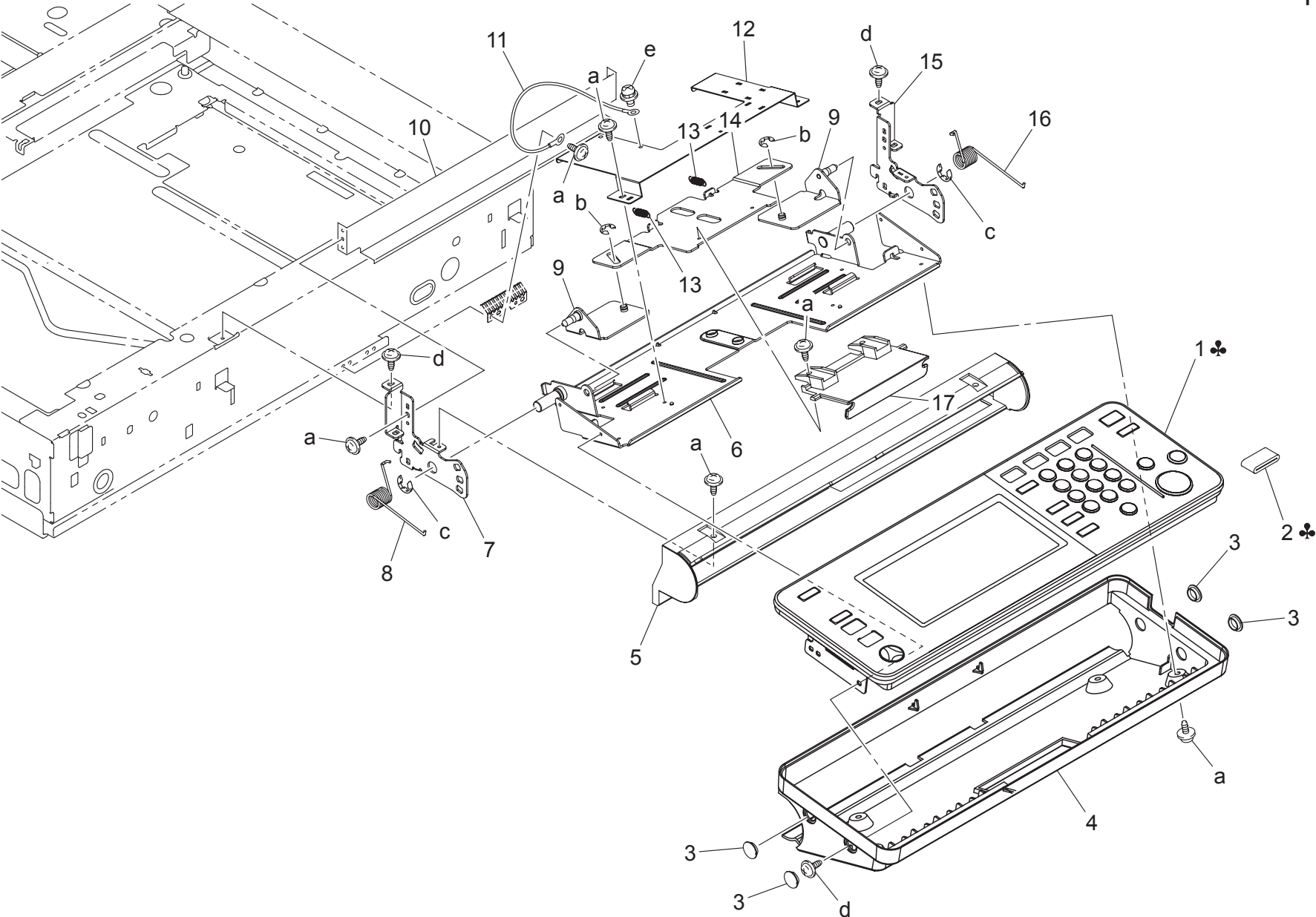



# CONTROL PANEL

Key	Part No.	Description	Destinations	Class	QTY	Standard parts
1	4037 6051 03	CONTROL PANEL ASSY	操作パネル ASSY	A	1	a-9735 0308 14 b-9721 0400 01 c-9721 0800 01 d-9735 0306 14 e-9646 0306 14
1	4037 6052 03	CONTROL PANEL ASSY	操作パネル ASSY	D,F2,G1,I,K,B,G2,F1	1	
1	4037 6053 03	CONTROL PANEL ASSY	操作パネル ASSY	C	1	
1	4037 6058 01	CONTROL PANEL ASSY	操作パネル ASSY	J	1	
1	4037 6059 01	CONTROL PANEL ASSY	操作パネル ASSY	H	1	
2	9326 1001 11	FERRITE CORE	フェライトコア	C,J,D,F2,G1,I,K,H	1	
3	1171 1321 01	CAP	キャップ		4	
4	4037 1398 01	COVER PANEL LOWER	下カバー 操作パネル		1	
5	4036 1399 03	COVER	カバー		1	
6	4036 1385 01	BRACKET	取付板		1	
7	4036 1380 02	HOLD PLATE	保持板		1	
8	4581 1379 01	TORSION SPRING	ねじりコイルばね		1	
9	4036 1390 01	POSITIONING PLATE	位置決め板		2	
10	4036 1388 01	BRACKET	取付板		1	
11	4036 6862 01	WIRE HARNESS ASSY	ハーネス ASSY		1	
12	4036 1387 02	BRACKET	取付板		1	
13	4581 1389 01	TENSION SPRING	引張コイルばね		2	
14	4036 1383 02	COUPLING	連結板		1	
15	4036 1386 02	HOLD PLATE	保持板		1	
16	4581 1382 01	TORSION SPRING	ねじりコイルばね		1	
17	4036 1381 03	LEVER	レバー		1	

# IR COVER

改訂版 REVISED EDITION	日付 DATE
	MAY 2005

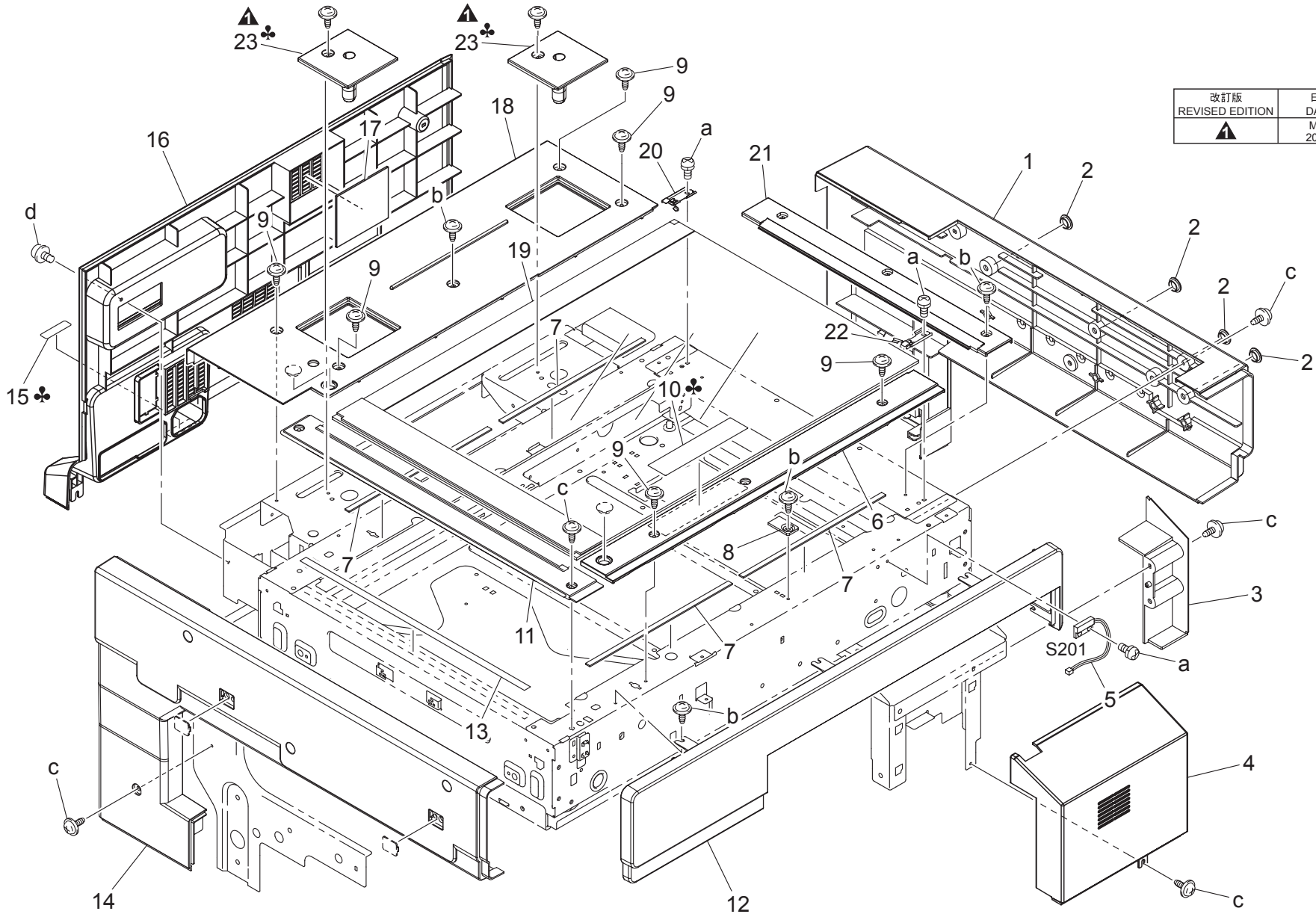

IR COVER

Key	Part No.	Description	Destinations	Class	QTY	Standard parts
1	4036 1395 07	COVER		C	1	a-9644 0306 14 b-9735 0306 14 c-9735 0308 14 d-9646 0306 14
2	4030 1041 01	CAP		C	4	
3	4036 1402 02	INNER COVER		D	1	
4	4037 1393 01	HOLD COVER F IR		C	1	
5	9334 2610 11	REED SWITCH		C	1	
6	4036 1392 02	COVER		C	1	
7	4036 1620 01	SEAL		C	4	
8	4581 1318 01	REGULATING PLATE		D	1	
9	4036 1410 01	SHOULDER SCREW		C	6	
10	4036 7342 01	LABEL	A	D	1	
10	4036 7343 01	LABEL DON'COPY	B,G2	C	1	
11	4036 1404 03	COVER		C	1	
12	4036 1391 03	FRONT COVER IR		C	1	
13	4581 1621 02	SEAL		C	1	
14	4036 1396 03	LEFT COVER IR		C	1	
15	4037 7403 01	LABEL GROUND	A,B,G2,H,F1,G2	C	1	
15	4037 7407 01	LABEL OUTLET	C,J,D,F2,G1,I,K	C	1	
16	4037 1405 02	COVER		C	1	
17	4025 2285 02	FILTER		C	1	
18	4036 1394 02	UPPER COVER IR		C	1	
19	4037 0752 00	ORIGINAL GLASS		C	1	
20	4581 1610 01	SET PLATE		C	1	
21	4036 1611 01	GUIDE		C	1	
22	4581 1605 03	SET PLATE		C	1	
23	4036 1397 01	COVER	(bizhub C351)	D	2	

SCANNER DRIVE SECTION

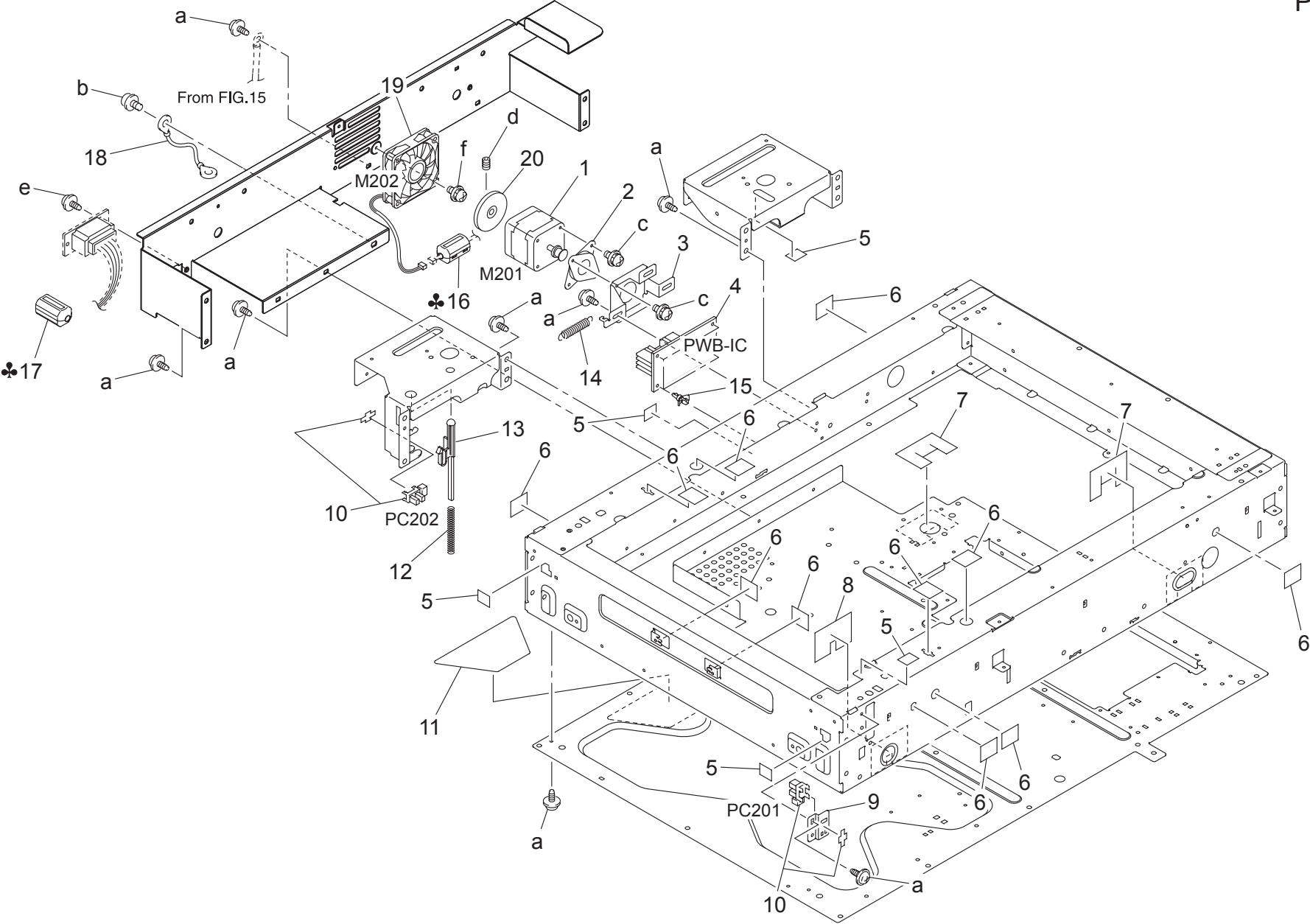



SCANNER DRIVE SECTION

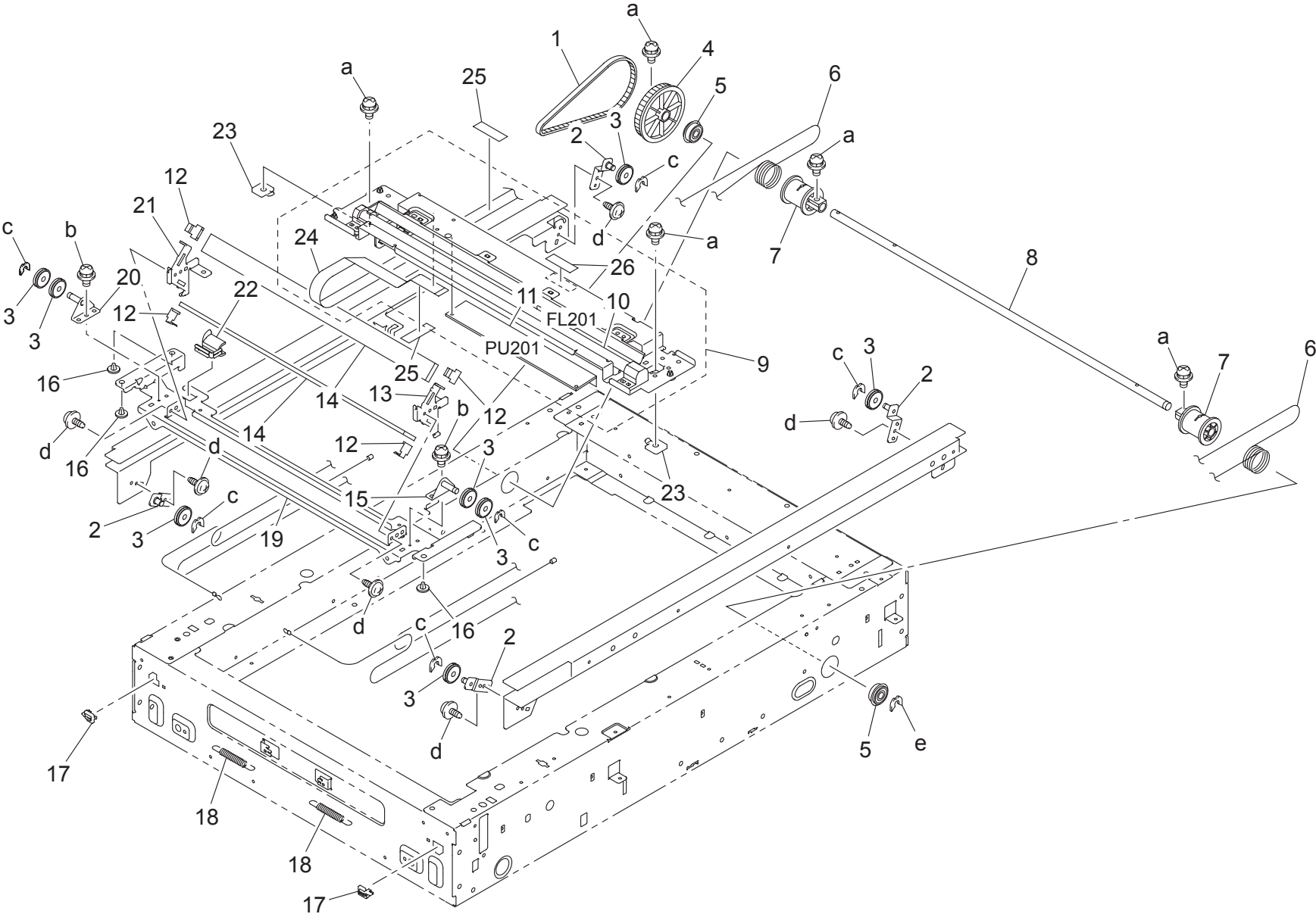



OPTICAL SECTION

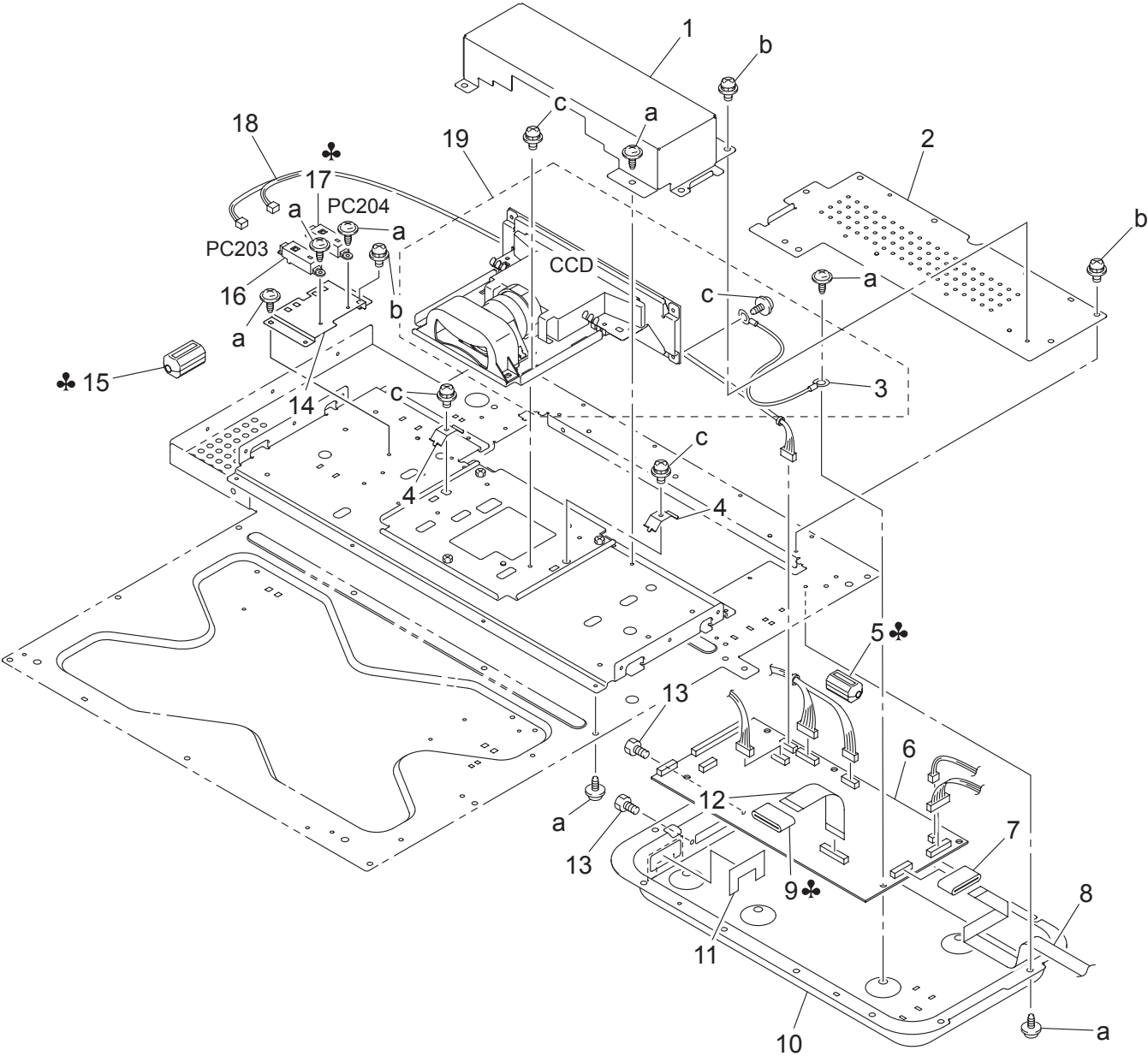



OPTICAL SECTION

Key	Part No.	Description	Destinations	Class	QTY	Standard parts
1	4036 1582 01	COVER		D	1	a-9735 0306 14 b-9646 0308 14 c-9646 0306 14
2	4036 1366 01	COVER		D	1	
3	4036 6862 01	WIRE HARNESS ASSY		D	1	
4	4581 1579 01	PLATE SPRING		D	2	
5	9326 1200 61	FERRITE CORE	C,J,D,F2,G1,I,K,H	D	1	
6	4037 0113 01	PWB-C		I	1	
7	9326 1001 11	FERRITE CORE		D	1	
8	4036 6858 01	WIRE HARNESS ASSY		D	1	
9	9326 1001 11	FERRITE CORE	C,J,D,F2,G1,I,K,H	D	1	
10	4036 1374 02	PLATE		D	1	
11	4036 1633 01	SEAL		D	1	
12	4036 6857 01	WIRE HARNESS ASSY		D	1	
13	4581 2269 02	SHOULDER SCREW		C	2	
14	4037 1590 01	BRACKET		D	1	
15	9326 1810 21	FERRITE CORE	C,J,D,F2,G1,I,K,H	D	1	
16	9335 1400 81	SOLID STATE SWITCH		C	1	
17	9335 1400 81	SOLID STATE SWITCH	A,C,J,B,G2,H (OPTION)	C	1	
17	9335 1400 81	SOLID STATE SWITCH	D,F2,G1,I,K,F1,G2	C	1	
18	4037 6854 01	WIRE HARNESS ASSY		D	1	
19	4037 0754 00	CCD UNIT		I	1	

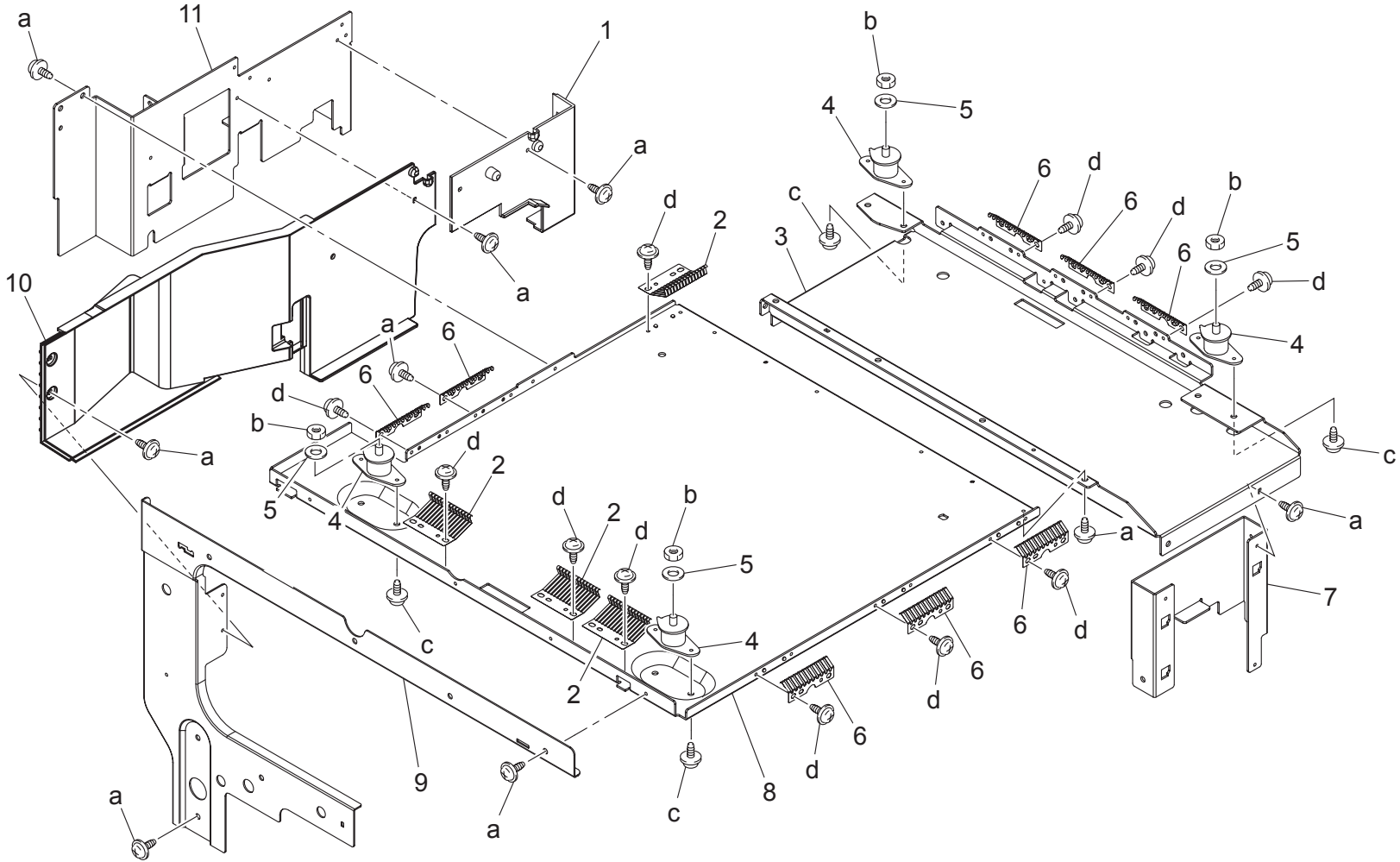



MAIN FRAME

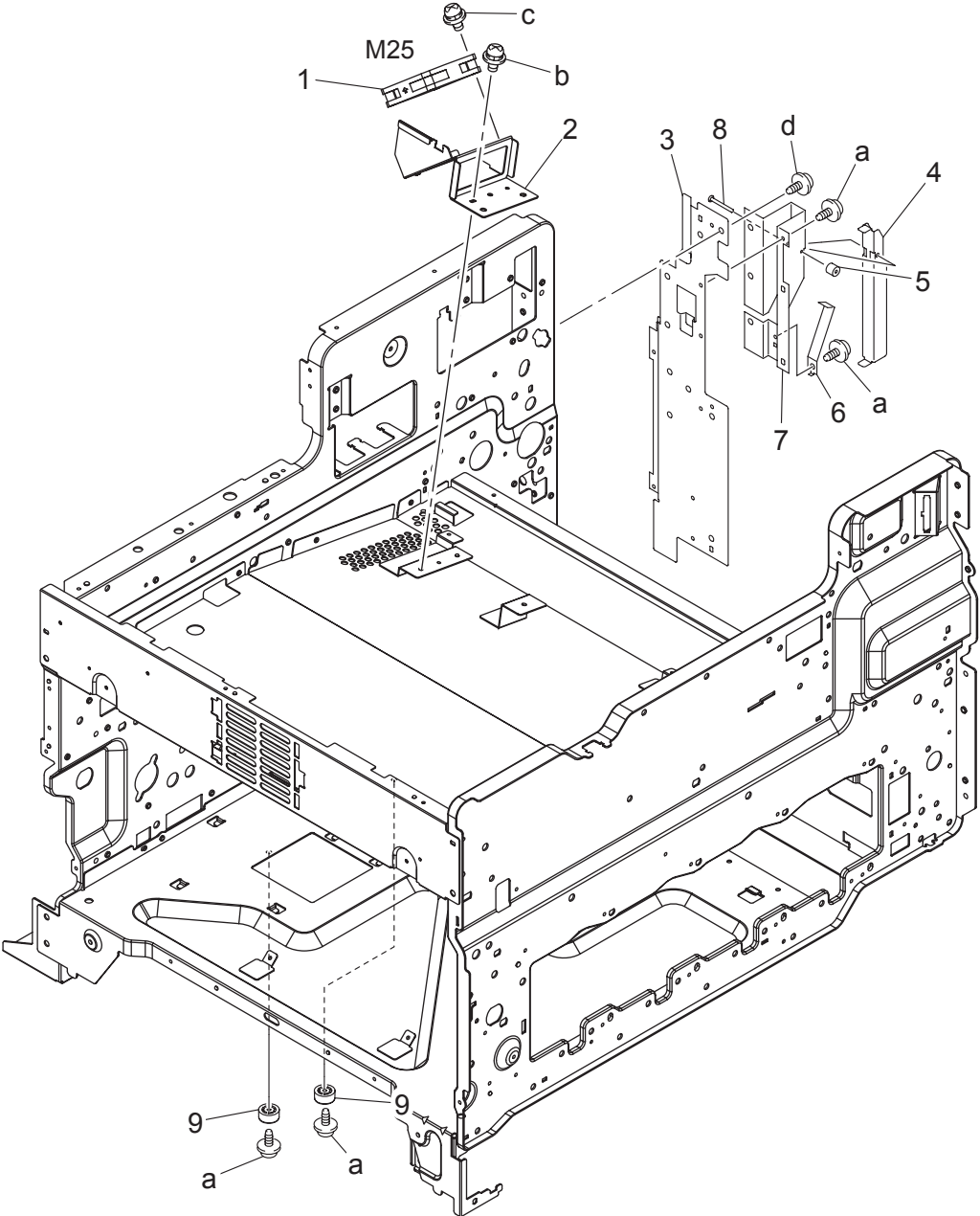

MAIN FRAME

Key	Part No.	Description	Destinations	Class	QTY	Standard parts
1	9313 1300 41	FAN MOTOR		C	1	a-9735 0308 14 b-9646 0306 14 c-9646 0320 14 d-9735 0306 14
2	4037 2454 03	BRACKET ファンモータ 取付板		D	1	
3	4036 2204 04	BRACKET 取付板		D	1	
4	4004 2025 01	HANDLE 取手		D	1	
5	1200 2105 05	COLLAR カラー		D	1	
6	4004 2026 01	PLATE SPRING 板ばね		D	1	
7	4036 2023 01	BRACKET 取付板		D	1	
8	1200 5211 05	SHAFT シャフト		D	1	
9	0996 3055 01	RUBBER FOOT コ`ムアシ		D	2	

# POWER UNIT

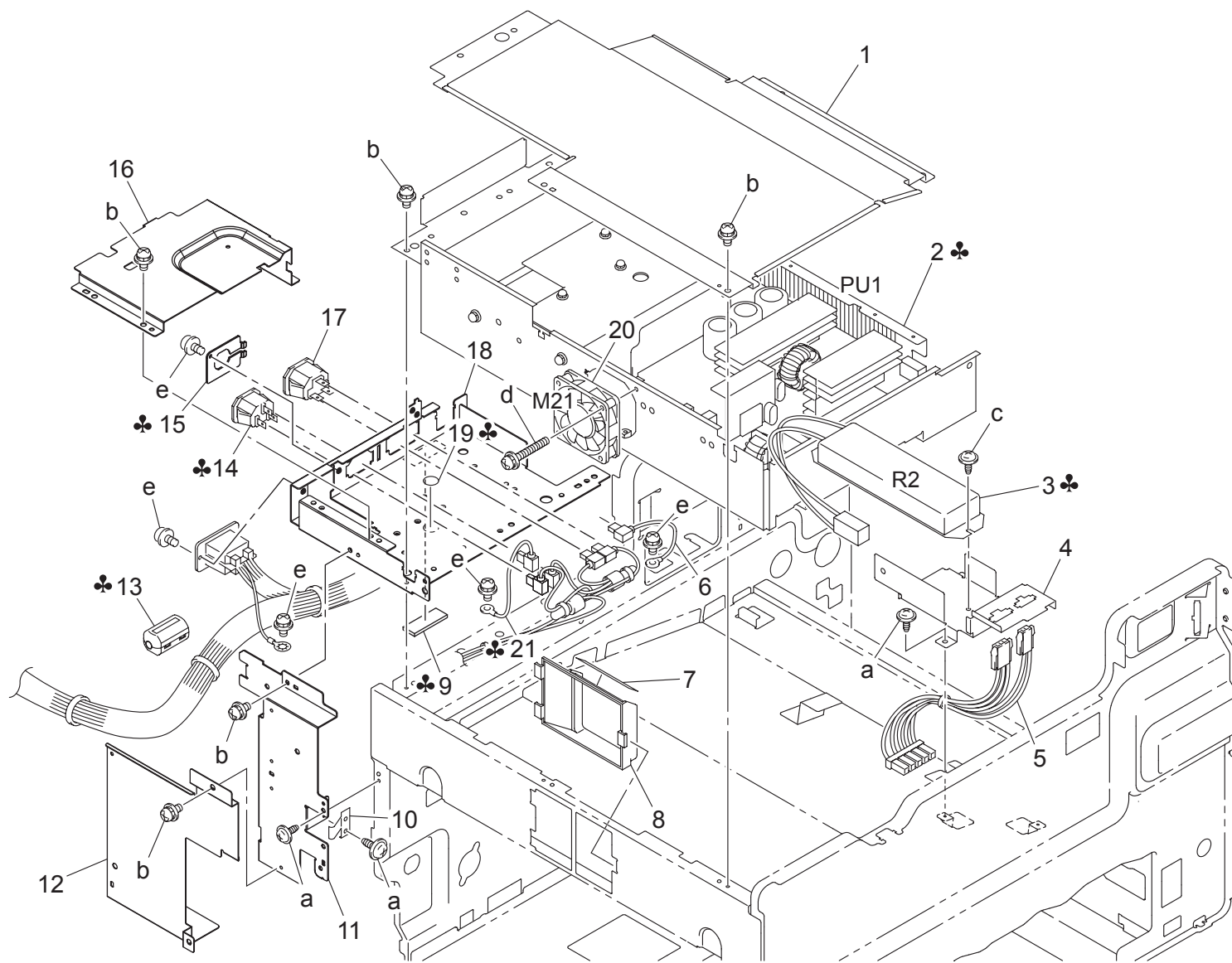

POWER UNIT

Key	Part No.	Description	Destinations	Class	QTY	Standard parts
1	4036 2211 03	SHIELD	シールド	D	1	a-9735 0308 14
2	4037 6211 02	POWER SUPPLY	直流安定化電源	I	1	b-9646 0308 14
2	4037 6212 02	POWER SUPPLY	直流安定化電源	I	1	c-9735 0408 14
3	9450 1806 01	RESISTOR	その他固定抵抗器	D	1	d-9646 0320 14
4	4036 2216 02	BRACKET	取付板	D	1	e-9646 0408 14
5	4036 6827 02	WIRE HARNESS ASSY	ハーネス ASSY	D	1	
6	4025 6805 01	WIRE HARNESS ASSY	ハーネス ASSY	D	1	
7	4004 2258 01	SEAL	シール	D	1	
8	4004 2257 01	DUCT	ダクト	D	1	
9	4037 6751 01	ELECTRICALLY CONDUCTIVE MATERIAL	導電材料	D	1	C,J,D,F2,G1,I,K,H
10	4004 1069 02	PLATE SPRING	板ばね	D	1	
11	4037 2205 01	BRACKET	取付板	D	1	
12	4037 2256 01	SHIELD	シールド	D	1	
13	9326 1810 21	FERRITE CORE	フェライトコア	D	1	C,J,D,F2,G1,I,K,H
14	9383 2510 21	HOLDER	ホルダー	D	1	C,J,D,F2,G1,I,K,B,G2,H,F1
15	4037 2239 01	BRACKET	取付板	D	1	A
16	4037 2208 02	SHIELD	シールド	D	1	
17	9383 5000 11	JACK	ジャック	D	1	
18	4037 2231 02	BRACKET	取付板	D	1	
19	1500 2320 02	LABEL EARTH	ラベル アース	D	1	A
20	9313 1000 61	FAN MOTOR	ファンモータ	C	1	
21	4025 6805 01	WIRE HARNESS ASSY	ハーネス ASSY	D	1	C,J,D,F2,G1,I,K,B,G2,H,F1

LEFT SIDE DOOR

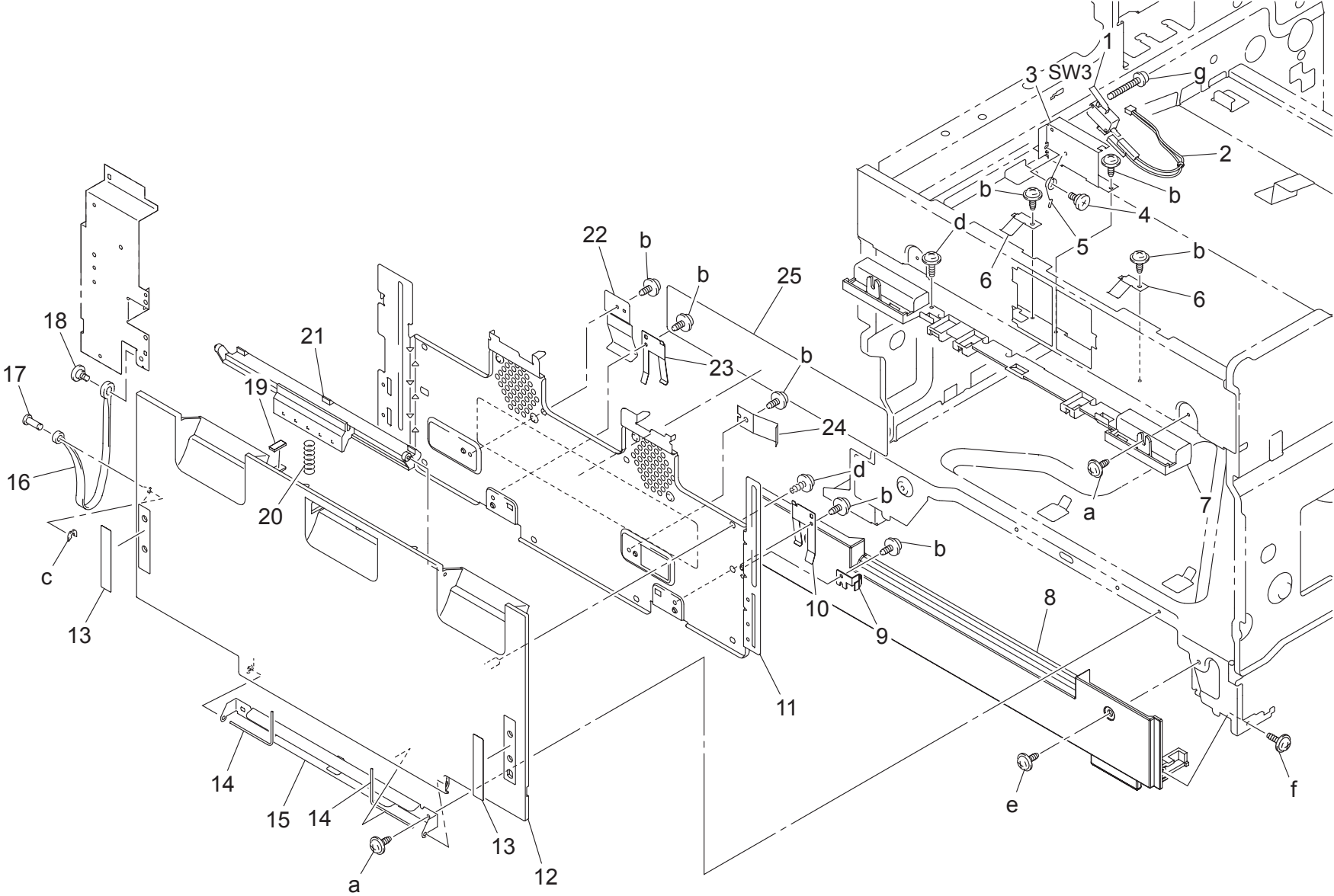



LEFT SIDE DOOR

Key	Part No.	Description	Destinations	Class	QTY	Standard parts
1	9331 2200 21	MICRO-SWITCH		C	1	a-9735 0308 14
2	4025 6814 01	WIRE HARNESS ASSY		D	1	b-9735 0306 14
3	4004 2255 02	BRACKET		D	1	c-4425 3002 01
4	4036 2257 01	SHOULDER SCREW		C	1	d-9739 0306 14
5	4004 2239 03	TORSION SPRING		C	1	e-9735 0408 14
6	4004 2254 01	PLATE SPRING		D	2	f-9739 0408 14
7	4036 2024 01	HANDLE		D	1	g-9646 0316 14
8	4036 2101 02	RAIL		D	1	
9	4004 1072 01	BRACKET		D	1	
10	4004 1067 02	PLATE SPRING		D	1	
11	4036 1010 02	REINFORCE PLATE		D	1	
12	4036 1005 03	COVER		C	1	
13	4036 1011 01	LABEL HIDE		C	2	
14	4036 1042 01	PIN		D	2	
15	4036 1015 01	BRACKET		D	1	
16	4036 1039 01	STOPPER		D	1	
17	4036 1040 01	PIN		D	1	
18	4134 3579 03	SHOULDER SCREW		C	1	
19	4025 1019 01	CUSHION		C	1	
20	4004 1014 01	PRESSURE SPRING		C	1	
21	4036 1013 01	HANDLE		C	1	
22	4025 1012 01	PLATE SPRING		D	1	
23	4004 1066 03	PLATE SPRING		D	1	
24	4004 1012 02	PLATE SPRING		D	1	
25	4036 7303 01	LABEL TONER BOX		D	1	

MAIN SWITCH SECTION

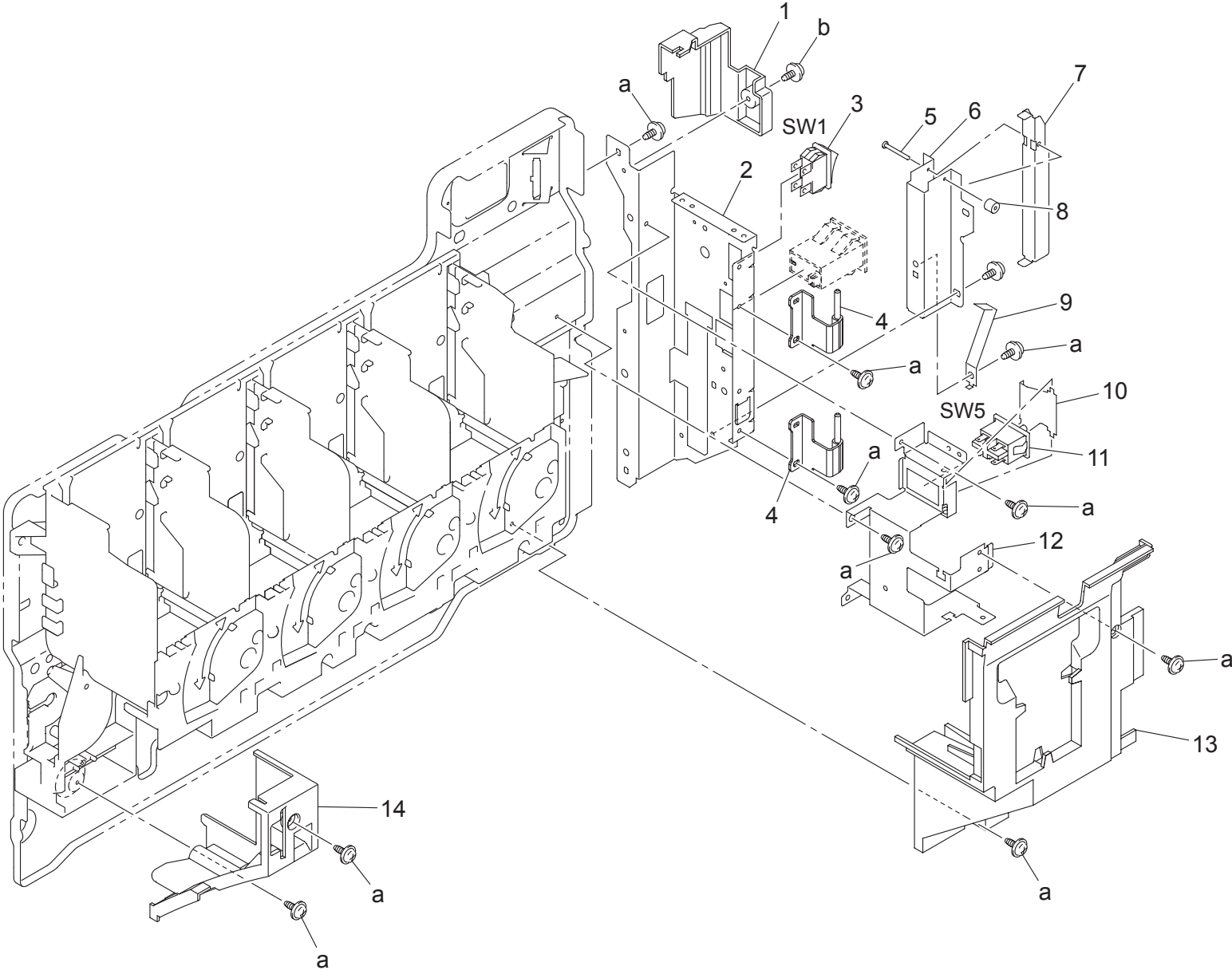

MAIN SWITCH SECTION

Key	Part No.	Description	Destinations	Class	QTY	Standard parts
1	4036 1052 03	COVER		D	1	a-9735 0308 14 b-9646 0308 14
2	4036 2212 02	BRACKET		D	1	
3	0990 6304 02	SWITCH		C	1	
4	4036 1025 02	HINGE		D	2	
5	1200 5211 05	SHAFT		D	1	
6	4004 2021 03	BRACKET		D	1	
7	4004 2025 01	HANDLE		D	1	
8	1200 2105 05	COLLAR		D	1	
9	4004 2026 01	PLATE SPRING		D	1	
10	4036 2245 01	LEVER		D	1	
11	9332 1710 41	SWITCH		C	1	
12	4036 2214 02	BRACKET		D	1	
13	4036 1051 01	COVER		D	1	
14	4036 1054 01	COVER		D	1	

PAPER SELECT SWITCH & LED LOCK

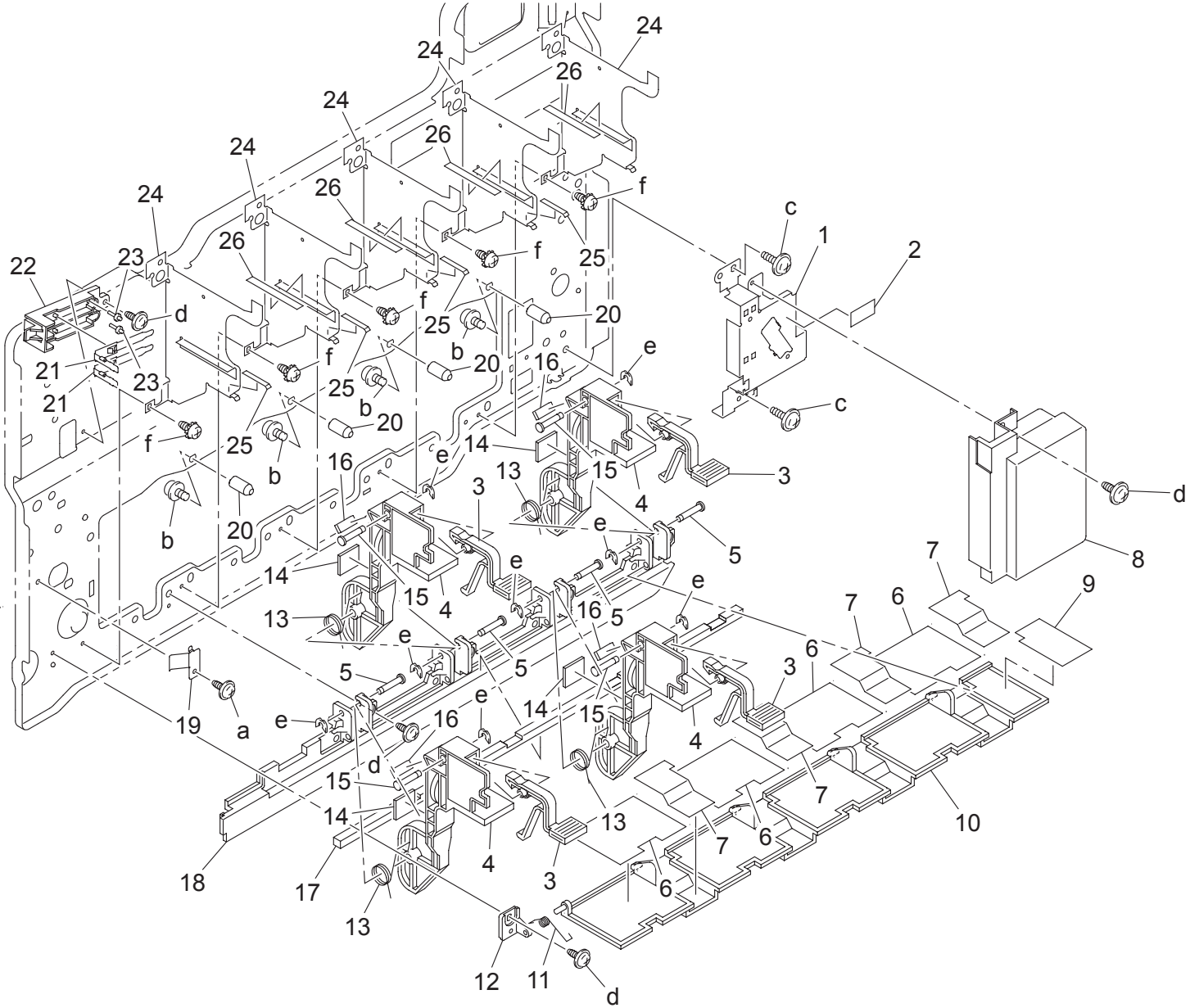



HOPPER SECTION

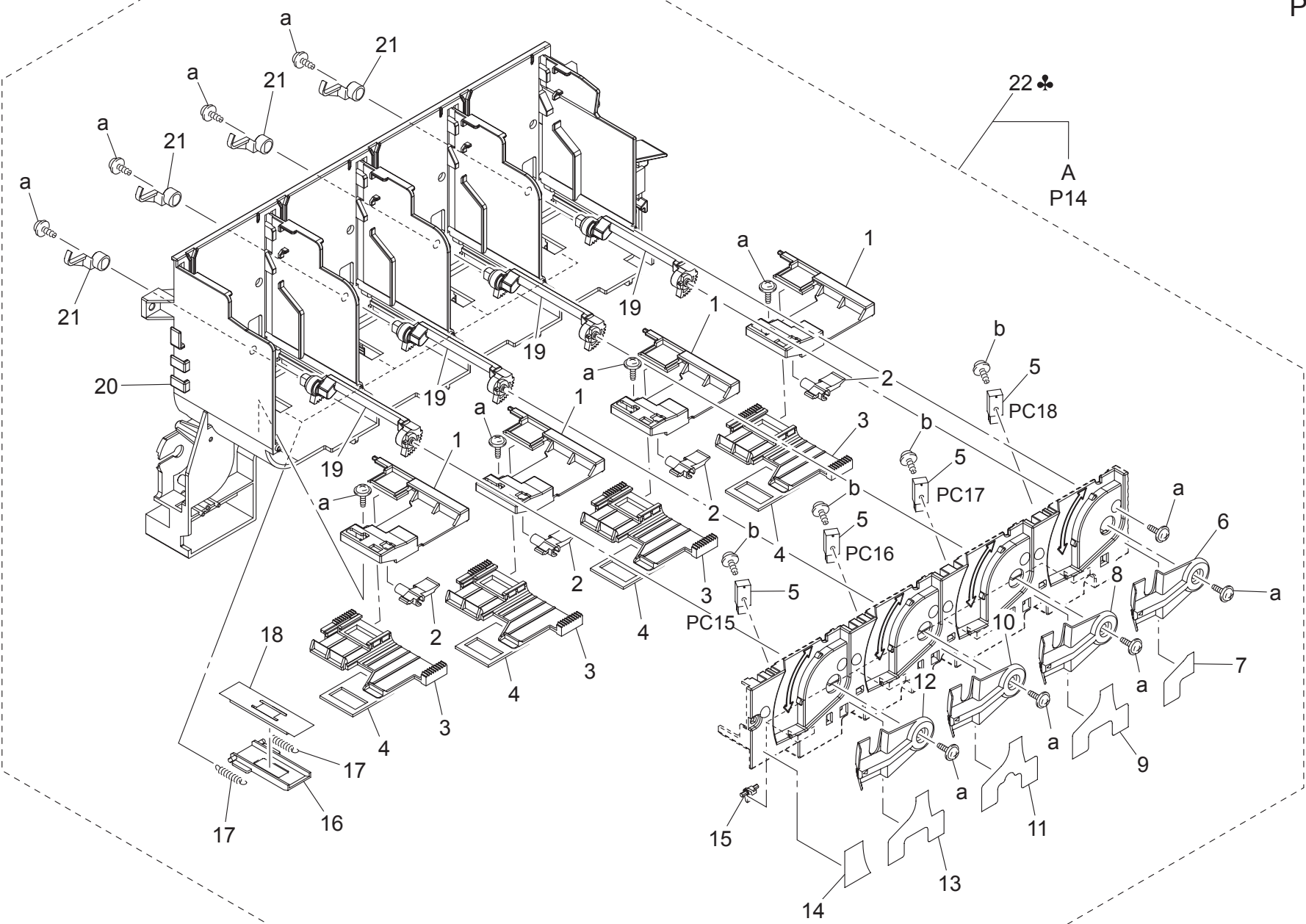

# HOPPER SECTION

Key	Part No.	Description	Destinations	Class	QTY	Standard parts
1	4036 5413 01	GUIDE		D	4	a-9739 0308 14 b-9739 0314 14
2	4036 5419 01	LEVER		D	4	
3	4036 5411 01	SHUTTER		D	4	
4	4025 5412 01	SEAL		D	4	
5	9335 1401 21	SOLID STATE SWITCH		C	4	
6	4025 5422 01	LEVER		C	1	
7	4036 7319 01	LABEL IU BLACK		D	1	
8	4025 5421 01	LEVER		C	1	
9	4036 7318 01	LABEL IU CYAN		D	1	
10	4025 5420 01	LEVER		C	1	
11	4036 7317 02	LABEL IU MAGENTA		D	1	
12	4025 5417 01	LEVER		C	1	
13	4036 7316 01	LABEL IU YELLOW		D	1	
14	4036 7315 01	LABEL LOCK RELEASE		D	1	
15	4036 5325 02	PAWL		D	4	
16	4036 5347 01	SHUTTER		D	4	
17	4036 5348 01	TENSION SPRING		C	8	
18	4036 5349 02	SEAL		D	4	
19	4036 5414 01	SHAFT		D	4	
20	4036 5301 03	HOUSING		D	1	
21	4025 5442 02	LEVER		D	4	
22	4037 0758 00	HOPPER	A	S	1	
22	4037 0759 00	HOPPER	B,G2	S	1	
22	4037 0760 00	HOPPER	C,J,D,F2,G1,I,K,H,F1,G2	S	1	

HOPPER SECTION

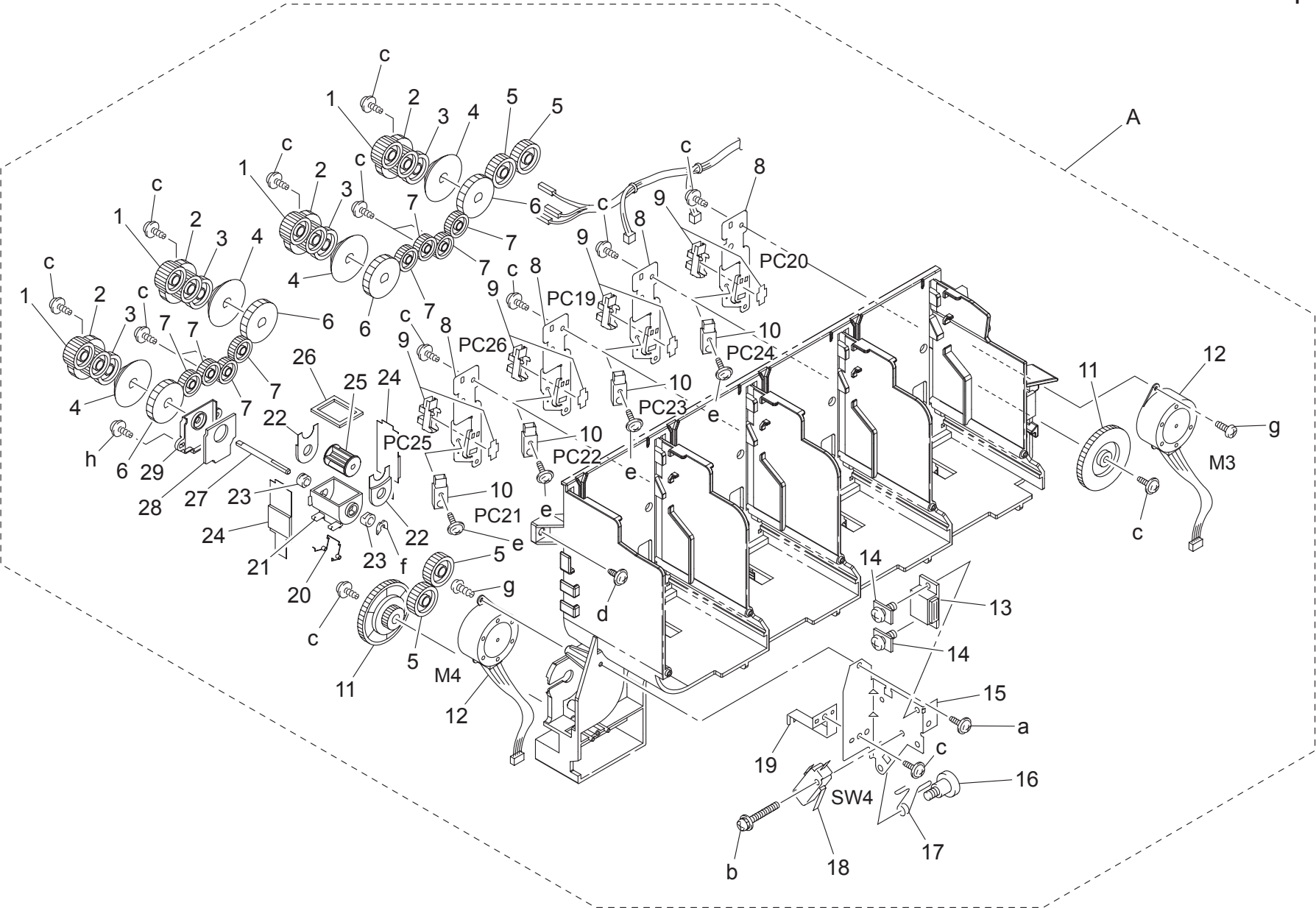



# HOPPER SECTION

Key	Part No.	Description	Destinations	Class	QTY	Standard parts
1	4025 5363 01	GEAR 16T		D	4	a-9739 0408 14
2	4025 5365 01	GEAR 14/28T		D	4	b-9646 0316 14
3	4025 5362 01	GEAR 14/22T		D	4	c-9739 0308 14
4	4004 5354 01	GEAR 19T		D	4	d-9735 0310 14
5	4025 5352 01	GEAR 30T		D	4	e-9735 0312 14
6	4004 5353 02	GEAR 40T		D	4	f-4425 3002 01
7	4004 5356 01	GEAR 22T		D	8	g-9732 0308 14
8	4025 5441 02	BRACKET		D	4	h-9739 0310 14
9	4037 0903 01	PHOTO INTERRUPTER		B	4	
10	9335 1401 01	SOLID STATE SWITCH		C	4	
11	4025 5351 01	GEAR 14/104T		C	2	
12	9314 1300 21	MOTOR		B	2	
13	1500 2640 04	MAGNET CATCH		D	1	
14	4036 1032 01	SCREW		D	2	
15	4004 1017 01	BRACKET		D	1	
16	4036 2257 01	SHOULDER SCREW		C	1	
17	4004 1041 01	TORSION SPRING		C	1	
18	9331 2200 21	MICRO-SWITCH		C	1	
19	4004 1030 01	CONTACT		D	1	
20	4025 5332 01	TORSION SPRING		C	4	
21	4025 5331 01	HOLDER		D	4	
22	1144 5336 02	SEAL		C	8	
23	4004 5339 01	BUSHING		C	8	
24	4025 5335 01	SEAL		D	8	
25	4004 5338 01	ROLLER		D	4	
26	4004 5337 01	SEAL		D	4	
27	4025 5333 01	SHAFT		D	4	
28	4025 5307 01	SEAL		D	4	
29	4036 5302 01	COVER		D	4	

OZONE FAN SECTION

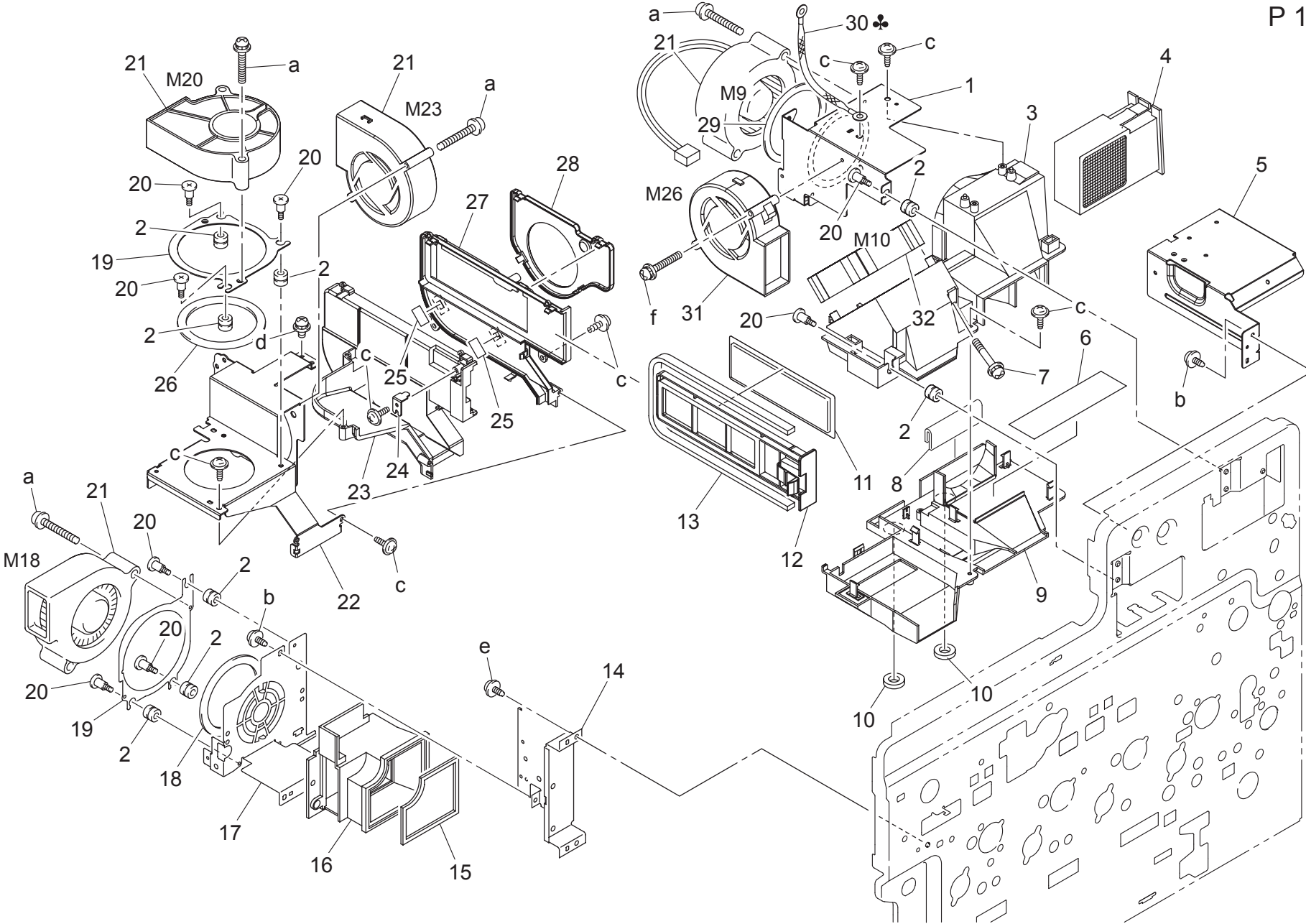

OZONE FAN SECTION

Key	Part No.	Description	Destinations	Class	QTY	Standard parts
1	4036 2459 02	BRACKET		D	1	a-9646 0440 14 b-9735 0308 14 c-9739 0308 14 d-9646 0308 14 e-9735 0306 14 f-9646 0320 14
2	4025 2294 01	BUSHING		C	8	
3	4037 2452 02	DUCT		D	1	
4	4053 0151 01	DEODORANT FILTER		A	1	
5	4037 2463 02	BRACKET		D	1	
6	4025 2458 01	SEAL		C	1	
7	4120 4614 01	SCREW		C	2	
8	4025 2466 01	SEAL		C	1	
9	4037 2453 03	DUCT		D	1	
10	4025 2468 01	SEAL		C	2	
11	4037 2491 01	DUST FILTER		C	1	
12	4037 2490 02	HOLDER		C	1	
13	4037 2493 02	SEAL		C	1	
14	4004 2230 03	BRACKET		D	1	
15	4004 2142 01	SEAL		C	1	
16	4004 2141 01	DUCT		D	1	
17	4036 2146 02	BRACKET		D	1	
18	4004 2148 01	SEAL		C	1	
19	4037 2486 01	BRACKET		D	2	
20	4036 2487 01	SHOULDER SCREW		C	8	
21	9313 1000 72	FAN MOTOR		C	4	
22	4037 2484 01	BRACKET		D	1	
23	4037 2483 04	DUCT		D	1	
24	4037 2494 01	GUIDE		D	1	
25	4037 2492 01	FILM		D	2	
26	4036 2485 01	SEAL		C	2	
27	4037 2488 03	DUCT		D	1	
28	4037 2489 02	DUCT		D	1	
29	4025 2465 01	SEAL		C	1	
30	4037 6812 01	WIRE HARNESS ASSY	C,J,D,F2,G1,I,K,H	D	1	
31	9313 1400 41	FAN MOTOR		C	1	
32	9313 1300 12	FAN MOTOR		B	1	

PC DRIVE SECTION

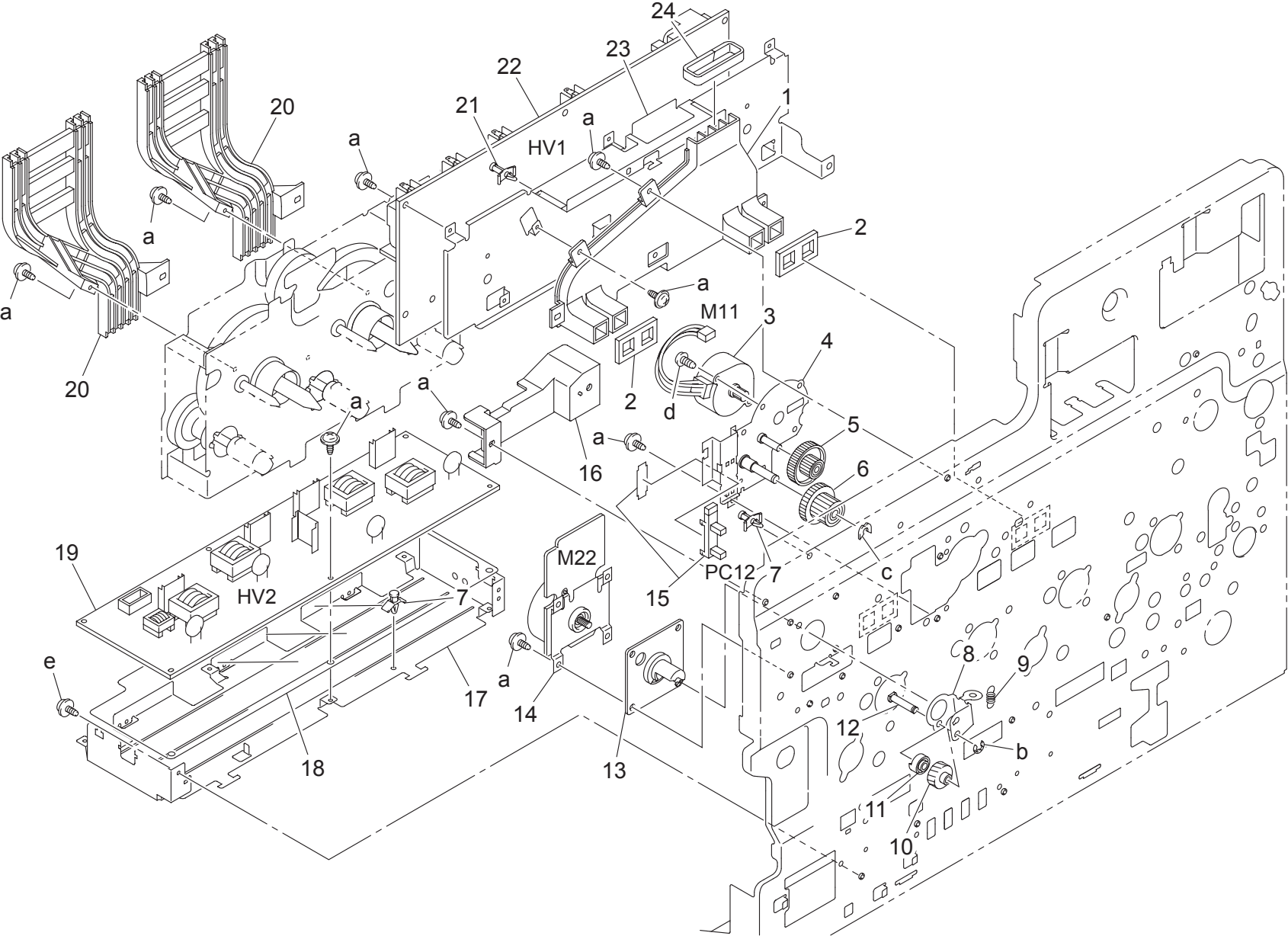





Key	Part No.	Description	Destinations	Class	QTY	Standard parts
1	4004 2540 01	GEAR 88T	ギヤ 88 T	C	1	a-9646 0306 14
2	4036 2754 02	GEAR 208T	ギヤ 208 T	C	1	b-9735 0306 14
3	1300 4342 07	BALL BEARING	ボールベアリング	C	2	c-9754 2016 08
4	4004 2547 01	PIN	ピン	D	1	d-9721 0400 01
5	4036 2541 01	SHAFT	シャフト	D	1	e-9721 0600 01
6	4036 2767 01	BUSHING	軸受	C	1	f-9752 2010 50
7	4036 2513 01	GEAR 53/83T	ギヤ 53/83 T	C	1	g-9752 2016 50
8	4036 2512 01	SHAFT	シャフト	D	1	k-9735 0308 14
9	4004 2545 01	GEAR 18/30T	ギヤ 18/30 T	C	2	m-9752 3016 50
10	4036 2538 01	GEAR 44/80T	ギヤ 44/80 T	C	1	n-9752 3012 50
11	4004 2546 01	BRACKET	取付板	D	1	p-9754 3022 08
12	4036 2515 01	GEAR 27/91T	ギヤ 27/91 T	C	1	
13	4036 2769 01	PRESSURE SPRING	圧縮コイルばね	D	1	
14	1200 3131 08	BUSHING	シムクウケ	C	6	
15	4036 2514 01	GEAR 19T	ギヤ 19 T	C	1	
16	4036 2766 02	JOINT	ジョイント	C	1	
17	4037 2542 01	GEAR	ギヤ	C	1	
18	4004 2509 01	JOINT	ジョイント	C	1	
19	4036 2775 01	CAP	キャップ	D	1	
20	4036 2774 01	JOINT	ジョイント	C	1	
21	4004 2503 01	PRESSURE SPRING	圧縮コイルばね	C	1	
22	4036 2520 01	SHAFT	シャフト	D	1	
23	4036 0208 01	BRACKET ASSY	取付板 ASSY	D	1	
24	4036 2531 01	SHAFT	シャフト	D	1	
25	9322 1300 31	CLUTCH	クラッチ	C	1	
26	4036 2544 01	GEAR 21/36T	ギヤ 21/36 T	C	1	
27	4036 2543 01	GEAR 32T	ギヤ 32 T	C	2	
28	4036 2537 01	BRACKET	取付板	D	1	
29	4036 2517 01	GEAR 52/114T	ギヤ 52/114 T	C	1	
30	4036 2752 01	HOLDER	ホルダ	D	1	
31	4036 2521 01	GEAR 40T	ギヤ 40 T	C	1	
32	4036 2764 01	SHAFT	シャフト	D	1	
33	9322 1300 41	CLUTCH	クラッチ	C	1	
34	4036 2519 01	GEAR 40T	ギヤ 40 T	C	1	
35	9384 1621 21	PWB SUPPORT 6.4H	キハンスポート	D	1	
36	4036 2511 01	FRAME	フレーム	D	1	
37	4036 2768 01	BUSHING	軸受	C	1	
38	1154 4670 01	PROTECTION	保護材	C	1	
39	4036 2762 01	BUSHING	軸受	C	1	
40	4037 0903 01	PHOTO INTERRUPTER	フォトインタラプター	B	2	
41	4036 2772 02	BRACKET	取付板	D	1	
42	9314 2400 21	MOTOR	ブラシレスモータ	B	1	
43	4036 2237 01	GUIDE	ガイド	D	1	
44	9314 2300 31	MOTOR	ブラシレスモータ	B	1	
45	1129 7303 01	LABEL HI-VOL CAUTION	ラベル 高圧注意	D	1	

# YMC DRIVE SECTION

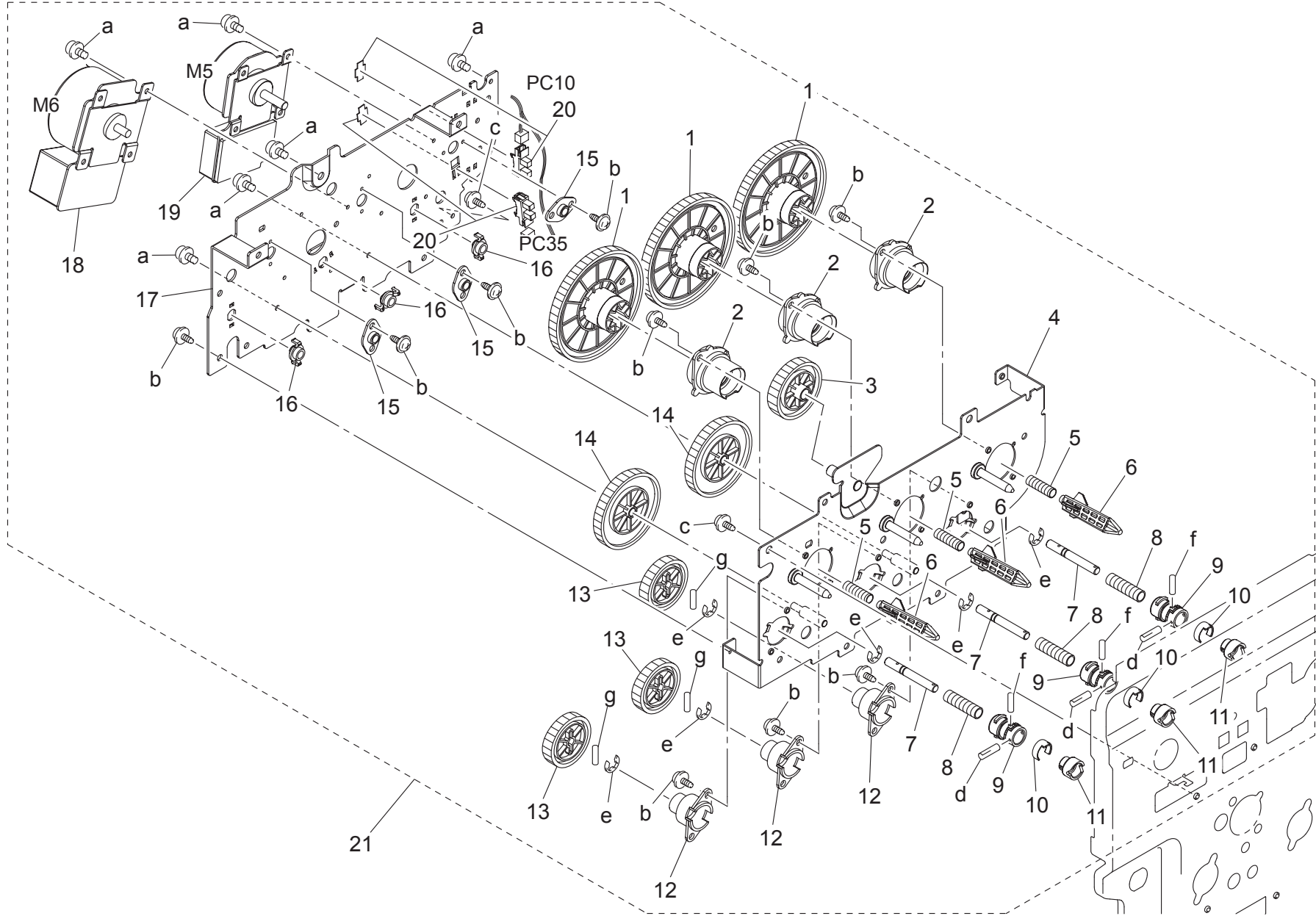





FUSING DRIVE SECTION

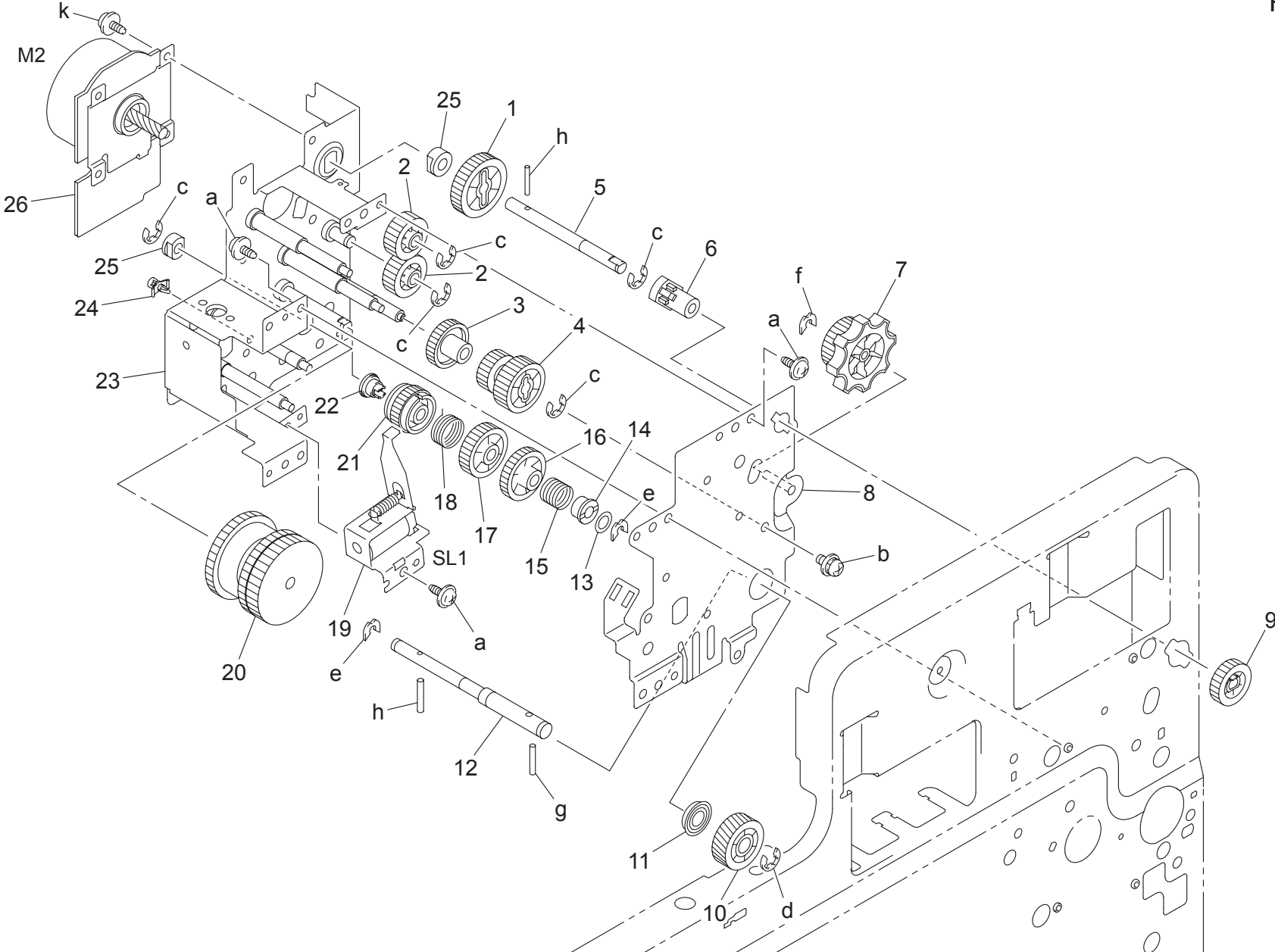

FUSING DRIVE SECTION

Key	Part No.	Description	Destinations	Class	QTY	Standard parts
1	4036 2561 01	GEAR 29T		C	1	a-9735 0308 14
2	4036 2567 01	GEAR 18T		C	2	b-9646 0308 14
3	4036 2560 01	GEAR 19T		C	1	c-9721 0400 01
4	4131 2571 01	GEAR 17/23T		C	1	d-9721 0600 01
5	4036 2563 01	SHAFT		D	1	e-4425 3001 01
6	4036 2565 01	BUSHING		C	1	f-4425 3002 01
7	4036 2585 01	KNOB		C	1	g-9752 3016 50
8	4036 0217 01	BRACKET ASSY		D	1	h-9752 2016 50
9	4036 2564 01	GEAR 26T		C	1	k-9735 0306 14
10	4036 2555 01	GEAR 23T		C	1	
11	1300 4342 07	BALL BEARING		C	1	
12	4036 2559 01	SHAFT		D	1	
13	1200 1342 05	WASHER		C	1	
14	4131 2590 01	DRUM		C	1	
15	4131 2591 01	TORSION SPRING		B	1	
16	4131 2577 01	GEAR 23T		C	1	
17	4131 2576 01	GEAR 23T		C	1	
18	4131 2579 03	TORSION SPRING		B	1	
19	9321 2400 51	SOLENOID		D	1	
20	4036 0153 01	DRIVING ASSY		C	1	
21	4131 2578 01	RATCHET		C	1	
22	4131 2575 01	DRUM		C	1	
23	4036 0209 01	BRACKET ASSY		D	1	
24	9384 1621 21	PWB SUPPORT 6.4H		D	1	
25	1200 3120 02	BUSHING		C	2	
26	9314 2300 31	MOTOR		B	1	

FUSING DRIVE SECTION

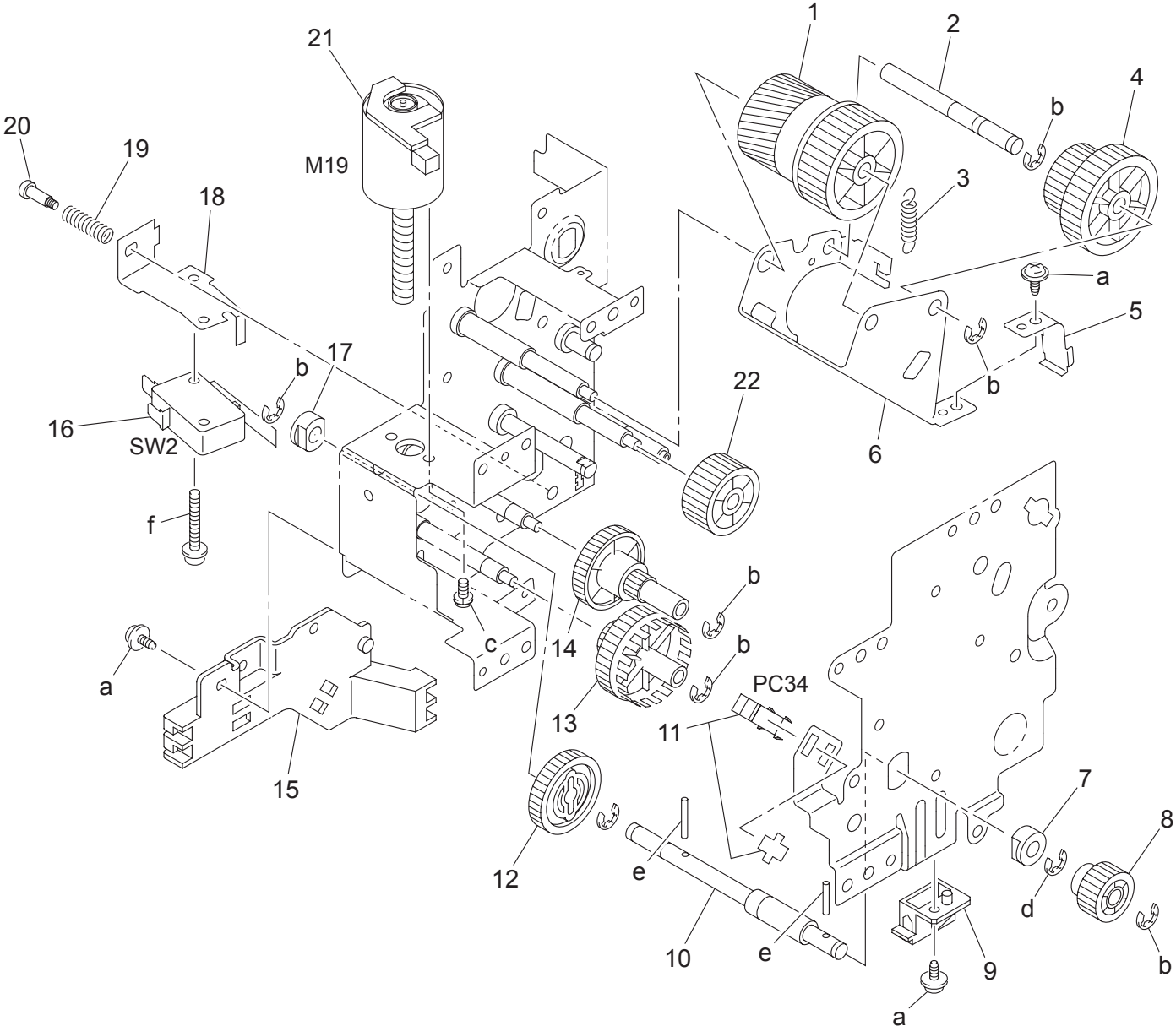



DUPLEX UNIT

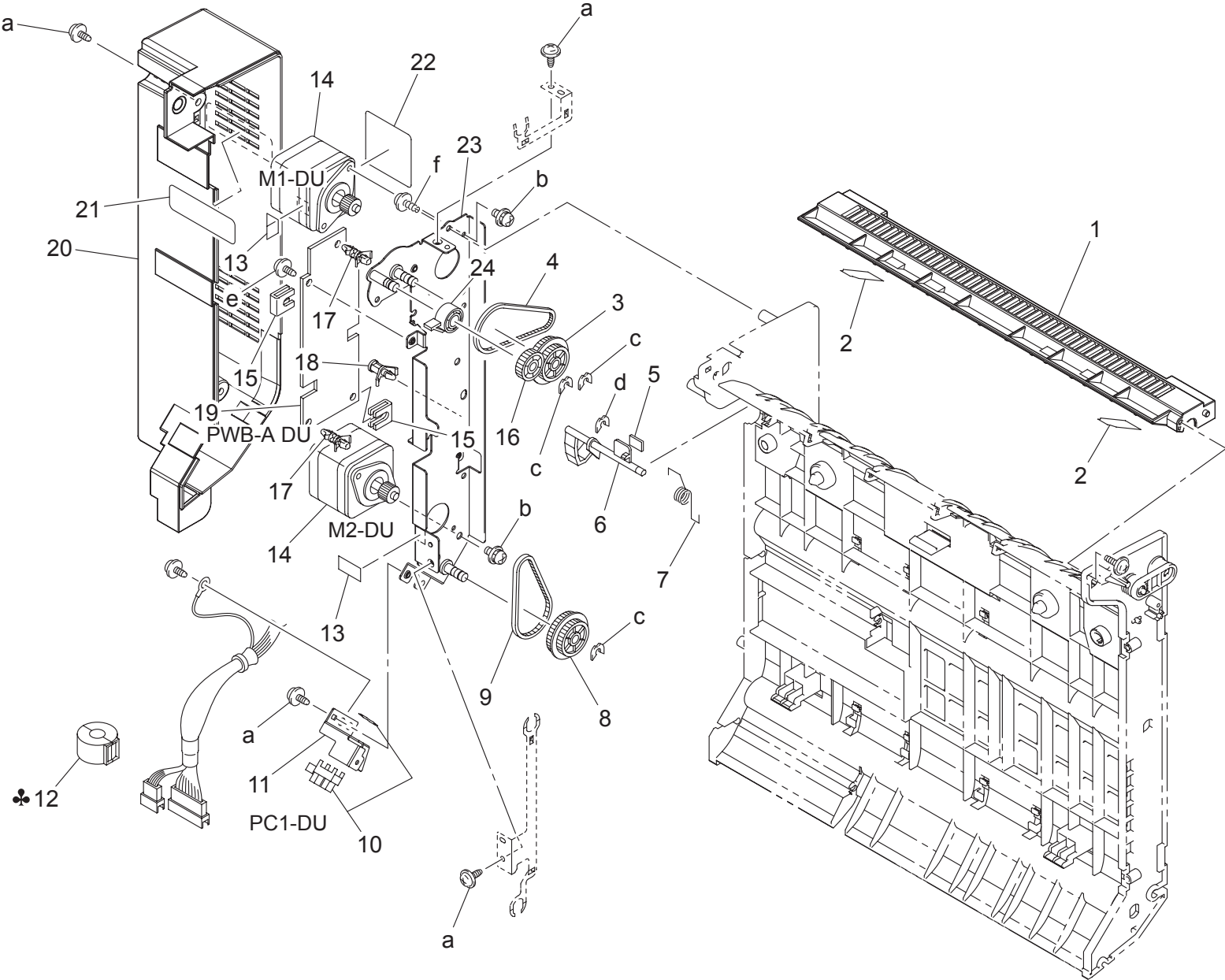

DUPLEX UNIT

Key	Part No.	Description	Destinations	Class	QTY	Standard parts
1	4535 3705 03	COVER		C	1	a-9735 0308 14 b-9646 0306 14 c-4425 3001 01 d-4425 3002 01 e-9735 0310 14 f-9739 0308 14
2	4535 3752 01	SLIDER		D	2	
3	4657 3745 01	GEAR 25/49T		C	1	
4	4657 3746 01	TIMING BELT 168L		C	1	
5	4657 3722 01	CUSHION		D	1	
6	4657 3730 02	ACTUATOR		C	1	
7	4657 3734 01	TORSION SPRING		C	1	
8	4657 3747 01	GEAR 25/33T		C	1	
9	4657 3743 01	TIMING BELT 134L		C	1	
10	4037 0903 01	PHOTO INTERRUPTER		B	1	
11	4535 3732 01	BRACKET		D	1	
12	9326 1410 31	FERRITE CORE	C,J,D,F2,G1,I,K,H	D	1	
13	4004 2266 01	TAPE		D	2	
14	9314 1001 01	MOTOR		B	2	
15	4657 3749 01	SPACER		D	2	
16	4657 3721 01	GEAR 18T		C	1	
17	9384 1900 56	PWB SUPPORT 6.35H		D	2	
18	9384 1621 21	PWB SUPPORT 6.4H		D	1	
19	4657 0101 01	PWB-A DU		I	1	
20	4535 3704 02	REAR COVER		C	1	
21	4657 3750 01	SEAL		C	1	
22	4037 3750 01	SEAL		C	1	
23	4535 0201 01	BRACKET ASSY		D	1	
24	4657 3723 02	RING		D	1	

DUPLEX UNIT

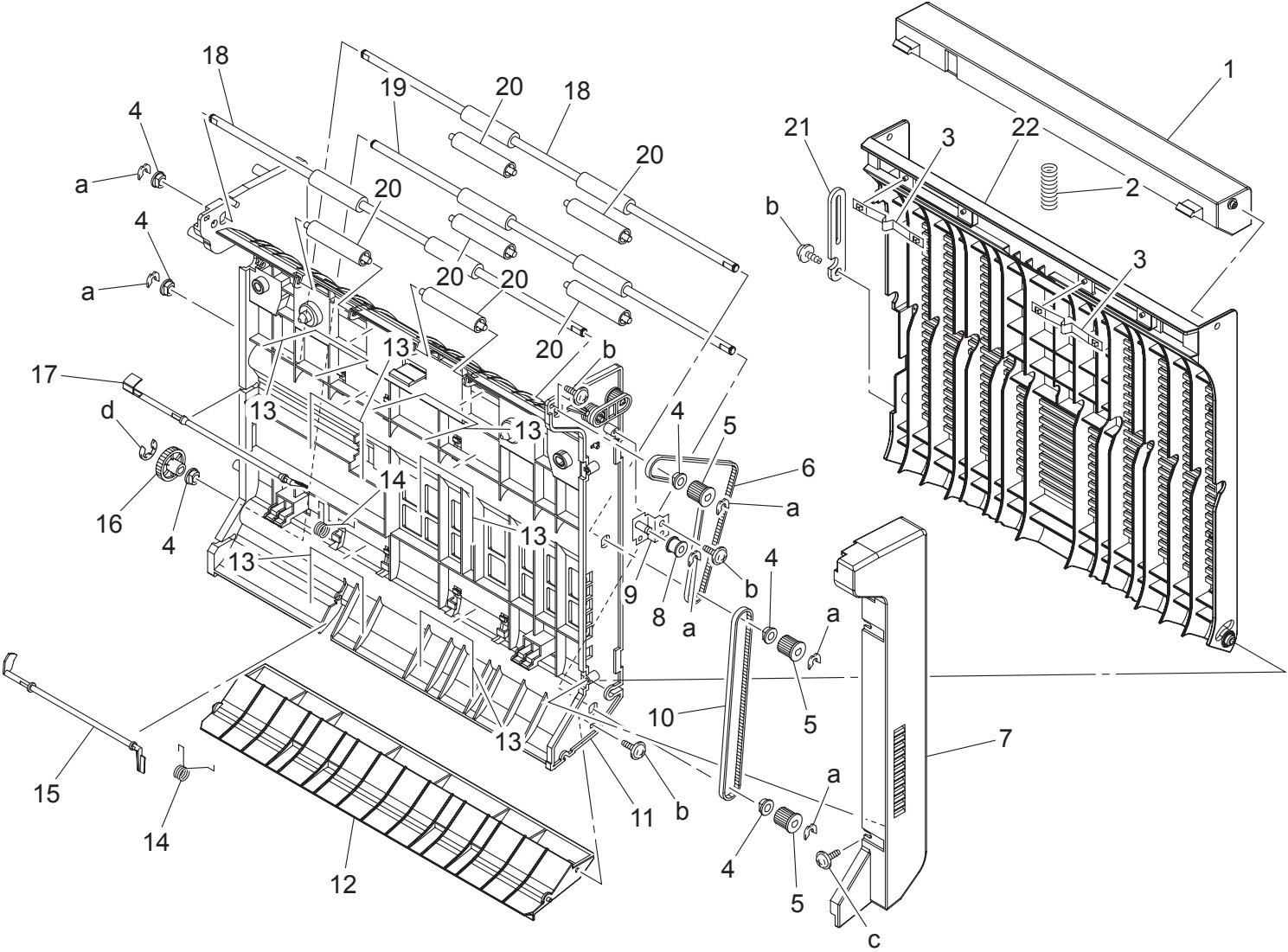



DUPLEX UNIT

Key	Part No.	Description	Destinations	Class	QTY	Standard parts
1	4535 3105 01	LEVER		C	1	a-4425 3001 01 b-9739 0308 14 c-9739 0310 14 d-9721 0400 01
2	4497 3106 03	PRESSURE SPRING		C	1	
3	4657 3736 01	PLATE SPRING		C	2	
4	1274 2611 01	BUSHING		C	6	
5	4657 3709 01	PULLEY 22T		C	3	
6	4535 3711 01	TIMING BELT 386L	タイミングベルト 386 L	C	1	
7	4535 3729 01	FRONT COVER	前カバー	C	1	
8	4657 3714 01	ROLL	ころ	C	1	
9	4657 0202 01	BRACKET ASSY	取付板 ASSY	D	1	
10	4535 3710 01	TIMING BELT 328L	タイミングベルト 328 L	C	1	
11	1484 0751 00	FRAME ASSY	フレーム ASSY	C	1	
12	4535 3703 02	COVER	カバー	C	1	
13	4497 3114 01	MEMBER	押え材	C	6	
14	4657 3735 01	TORSION SPRING	ねじりコイルばね	C	2	
15	4535 3731 01	ACTUATOR	アクチュエータ	C	1	
16	4657 3708 02	GEAR 25T	ギヤ 25 T	C	1	
17	4535 3724 01	ACTUATOR	アクチュエータ	C	1	
18	4535 3706 01	ROLLER	ローラ	C	2	
19	4535 3707 01	ROLLER	ローラ	C	1	
20	4497 3116 01	ROLL	ころ	C	6	
21	4497 3109 02	STOPPER	ストッパー	D	1	
22	4535 3702 01	COVER	カバー	D	1	



MULTI MANUAL FEED SECTION

Key	Part No.	Description	Destinations	Class	QTY	Standard parts
1	4030 3466 02	COVER		C	1	a-9735 0308 14 b-9739 0308 14 c-9735 0306 14 d-9646 0306 14
2	4037 0906 01	PHOTO INTERRUPTER		B	4	
2	4537 0901 01	PHOTO INTERRUPTER		B	4	
3	1200 5212 04	PIN		D	4	
4	4030 3414 01	BRACKET		D	4	
5	4030 3415 01	ACTUATOR		C	4	
6	4030 3446 01	TORSION SPRING		C	4	
7	9326 1200 61	FERRITE CORE	C,J,D,F2,G1,I,K,H	D	1	
8	4030 3461 01	MEMBER		D	1	
9	4030 3423 03	TRAY		C	1	
10	4030 3459 02	COVER		C	1	
11	4030 7305 01	LABEL	A	C	1	
11	4030 7309 02	LABEL TRAY CAUTION	C,J,D,F2,G1,I,K,B,G2,H,F1	C	1	
12	4030 3408 03	TRAY		C	1	
13	4036 3860 02	FRONT COVER		C	1	
14	4030 3437 01	BRACKET		D	1	
15	4030 3435 01	TORSION SPRING		C	1	
16	4030 3473 02	HOLDER		D	1	
17	4030 0216 03	BRACKET ASSY		D	1	
18	4030 3460 02	RACK		C	1	
19	4030 3412 01	GEAR 13/18T		C	1	
20	4030 3455 02	BRACKET		D	1	
21	4037 6899 01	RESISTOR		D	1	
22	4131 4623 03	CLEANING PAD		C	2	
23	4030 3410 03	REGULATING PLATE		C	1	
24	4036 7311 01	SCALE INCH	B,G2	C	1	
24	4036 7312 01	SCALE METRIC	A,C,J,D,F2,G1,I,K,H,F1,G2	C	1	
25	4036 7341 01	LABEL MANU FEED		C	1	
26	4030 3486 01	BRAKE		C	1	
27	4030 3411 03	REGULATING PLATE		C	1	
28	4030 3487 01	BRAKE		C	1	
29	4030 6814 03	WIRE HARNESS ASSY		D	1	
30	4030 3436 01	TORSION SPRING		C	1	
31	4030 3472 01	HOLDER		D	1	
32	4036 3856 02	REAR COVER		C	1	

MULTI MANUAL FEED SECTION

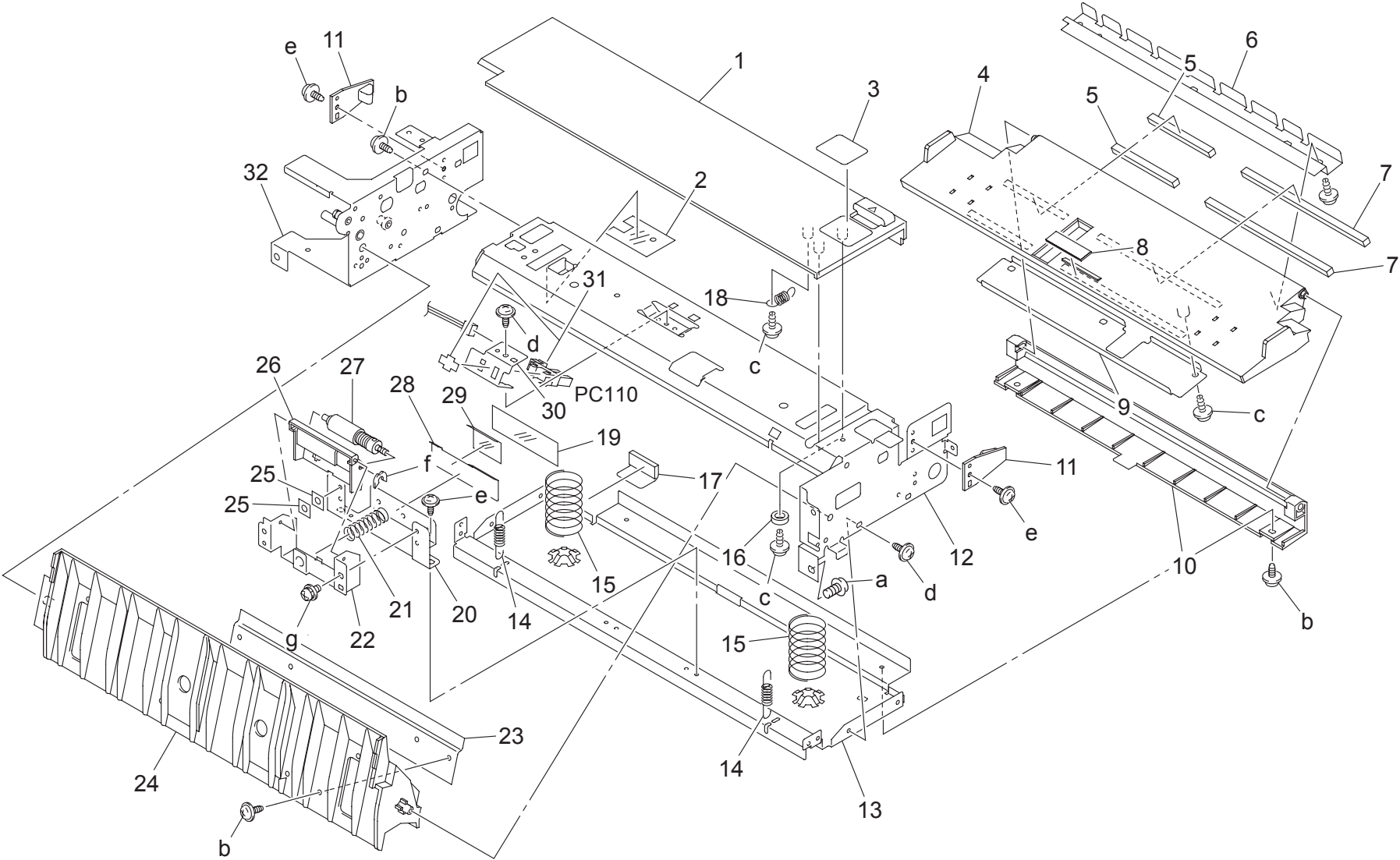

MULTI MANUAL FEED SECTION

Key	Part No.	Description	Destinations	Class	QTY	Standard parts
1	4036 3857 01	COVER		D	1	a-9743 0408 14 b-9735 0308 14 c-9739 0308 14 d-9735 0306 14 e-4154 3804 01 f-4425 3002 01 g-9646 0306 14
2	4030 3447 01	GUIDE		C	1	
3	4030 3754 01	LABEL		C	1	
4	4030 3409 14	LIFTING PLATE		D	1	
5	4030 3476 01	SEAL		C	2	
6	4030 3484 01	WEIGHT		D	1	
7	4030 3477 01	SEAL		C	2	
8	4687 3281 01	FRICTION SHEET		C	1	
9	4030 3456 01	REINFORCE PLATE		D	1	
10	4030 3425 01	HOLDER		D	1	
11	4030 3430 01	LEVER		C	2	
12	4030 3432 04	BRACKET		D	1	
13	4030 3424 01	BRACKET		D	1	
14	4030 3428 01	TENSION SPRING		C	2	
15	4030 3457 03	PRESSURE SPRING		C	2	
16	4030 3481 01	COLLAR		C	2	
17	4030 3448 01	CUSHION		C	1	
18	4030 3438 01	TENSION SPRING		C	1	
19	4030 3489 01	SEAL		C	1	
20	4030 3474 01	BRACKET		D	1	
21	4030 3475 01	PRESSURE SPRING		C	1	
22	4030 3404 01	BRACKET		D	1	
23	4030 3427 01	REINFORCE PLATE		D	1	
24	4030 3401 13	HOLDER		D	1	
25	4030 3492 01	SPACER		C	2	
26	4131 3053 02	HOLDER		D	1	
27	4034 0151 01	SEPARATION ROLLER		A	1	
28	4030 3402 01	GUIDE PLATE		C	1	
29	4030 3403 01	GUIDE		C	1	
30	4030 3443 02	BRACKET		D	1	
31	4037 0906 01	PHOTO INTERRUPTER		B	1	
31	4537 0901 01	PHOTO INTERRUPTER		B	1	
32	4036 0240 01	FRAME ASSY		D	1	

MULTI MANUAL FEED SECTION

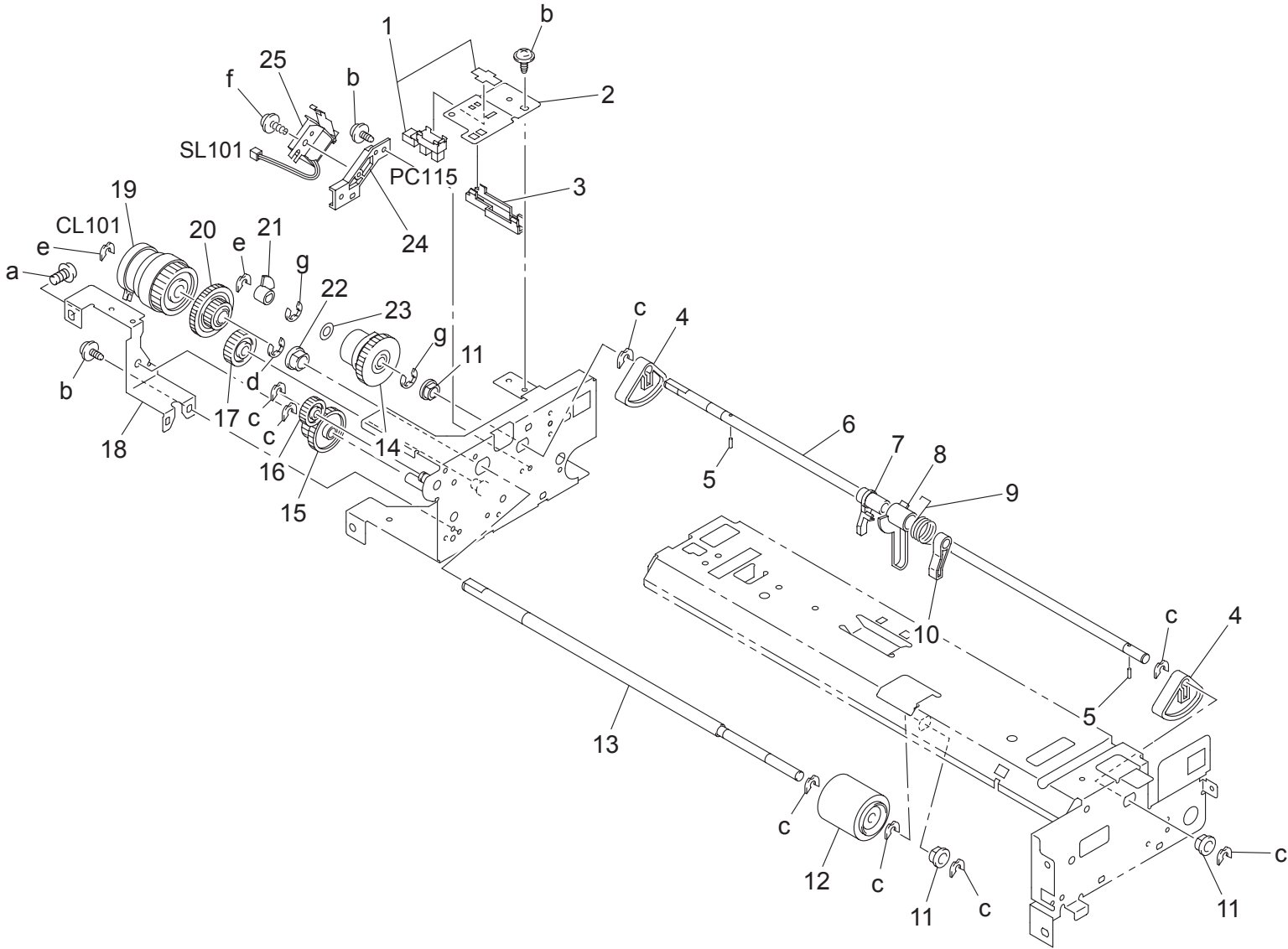



PAPER TAKE-UP SECTION

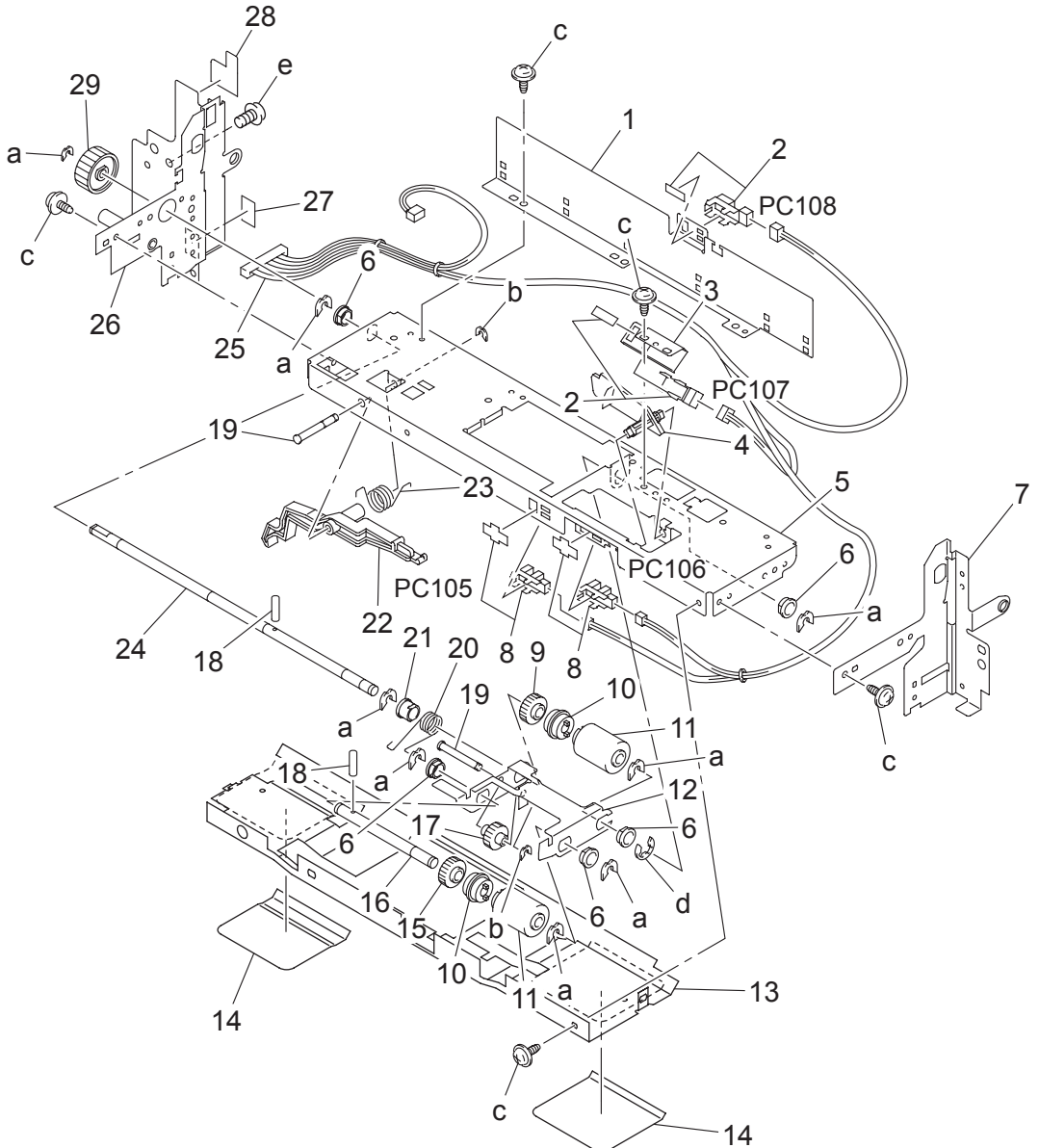



PAPER TAKE-UP SECTION

Key	Part No.	Description	Destinations	Class	QTY	Standard parts
1	4036 3830 01	BRACKET		D	1	a-4425 3001 01 b-4425 3002 01 c-9735 0306 14 d-9721 0400 01 e-9743 0408 14
2	4037 0902 01	PHOTO INTERRUPTER		B	2	
3	4348 3049 01	BRACKET		D	1	
4	4030 3016 12	ACTUATOR		C	1	
5	4030 3010 02	FRAME		D	1	
6	4131 3003 01	BUSHING		C	5	
7	4036 3816 12	FRAME		D	1	
8	4037 0906 01	PHOTO INTERRUPTER		B	2	
8	4537 0901 01	PHOTO INTERRUPTER		B	2	
9	4425 3013 01	GEAR 30T		C	1	
10	4030 3034 01	CLUTCH		C	2	
11	4030 3005 01	ROLLER		A	2	
12	4030 3002 02	HOLDER		D	1	
13	4030 3095 01	GUIDE PLATE		D	1	
14	4030 3036 01	GUIDE		C	2	
15	4425 3016 01	GEAR 32T		C	1	
16	4030 3003 01	SHAFT		D	1	
17	4030 3008 01	GEAR 29T		C	1	
18	1067 2501 01	PIN		C	2	
19	4030 3020 01	SHAFT		D	2	
20	4030 3030 01	TORSION SPRING		C	1	
21	1065 3086 01	BUSHING		C	1	
22	4030 3011 02	LEVER		C	1	
23	4030 3012 01	TORSION SPRING		C	1	
24	4348 3047 01	SHAFT		D	1	
25	4036 6824 02	WIRE HARNESS ASSY		D	1	
26	4036 0238 02	FRAME ASSY		D	1	
27	4036 3861 01	TAPE		D	1	
28	4036 3835 01	SHIELD PLATE		D	1	
29	4348 3029 01	GEAR 32T		C	1	



PAPER TAKE-UP SECTION

Key	Part No.	Description	Destinations	Class	QTY	Standard parts
1	4036 3822 01	DOOR	扉	C	1	a-9646 0306 14
2	4036 3827 01	PRESSURE SPRING	圧縮コイルばね	C	2	b-4425 3001 01
3	4348 3071 01	SHAFT	シャフト	D	1	c-9735 0306 14
4	4030 3122 01	ROLL	ころ	C	4	d-9743 0306 14
5	4036 3833 01	HANDLE	取手	D	1	e-9721 0600 01
6	4036 3823 01	LEVER	レバー	C	1	f-9721 0400 01
7	4036 3832 01	BRACKET	取付板	D	1	g-9739 0308 14
8	4030 3116 01	TENSION SPRING	引張コイルばね	C	1	h-9735 0308 14
9	4163 5293 01	SCREW	ねじ	C	3	
10	4036 3837 02	GUIDE	ガイド	D	1	
11	4036 3819 12	GUIDE PLATE	ガイド板	D	1	
12	4036 3818 01	HOLDER	ホルダ	C	2	
13	4348 3011 03	ROLLER	ローラ	C	1	
14	4348 3048 01	GEAR 19/40T	ギヤ 19 / 40 T	C	1	
15	4036 0239 01	BRACKET ASSY	取付板 ASSY	D	1	
16	4348 3031 01	GEAR 19/32T	ギヤ 19 / 32 T	C	2	
17	4036 3839 01	GEAR 31T	ギヤ 31 T	C	1	
18	4036 3841 02	BRACKET	取付板	D	1	
19	4036 3831 01	PRESSURE SPRING	圧縮コイルばね	D	1	
20	4037 0906 01	PHOTO INTERRUPTER	フォトインタラプター	B	1	
20	4537 0901 01	PHOTO INTERRUPTER	フォトインタラプター	B	1	
21	4348 3028 01	GEAR 22T	ギヤ 22 T	C	1	
22	4036 3834 01	GUIDE PLATE	ガイド板	D	1	
23	4030 3115 01	LEVER	レバー	C	1	
24	4036 3825 01	EARTH GROUND	アース	D	1	

PAPER TAKE-UP SECTION

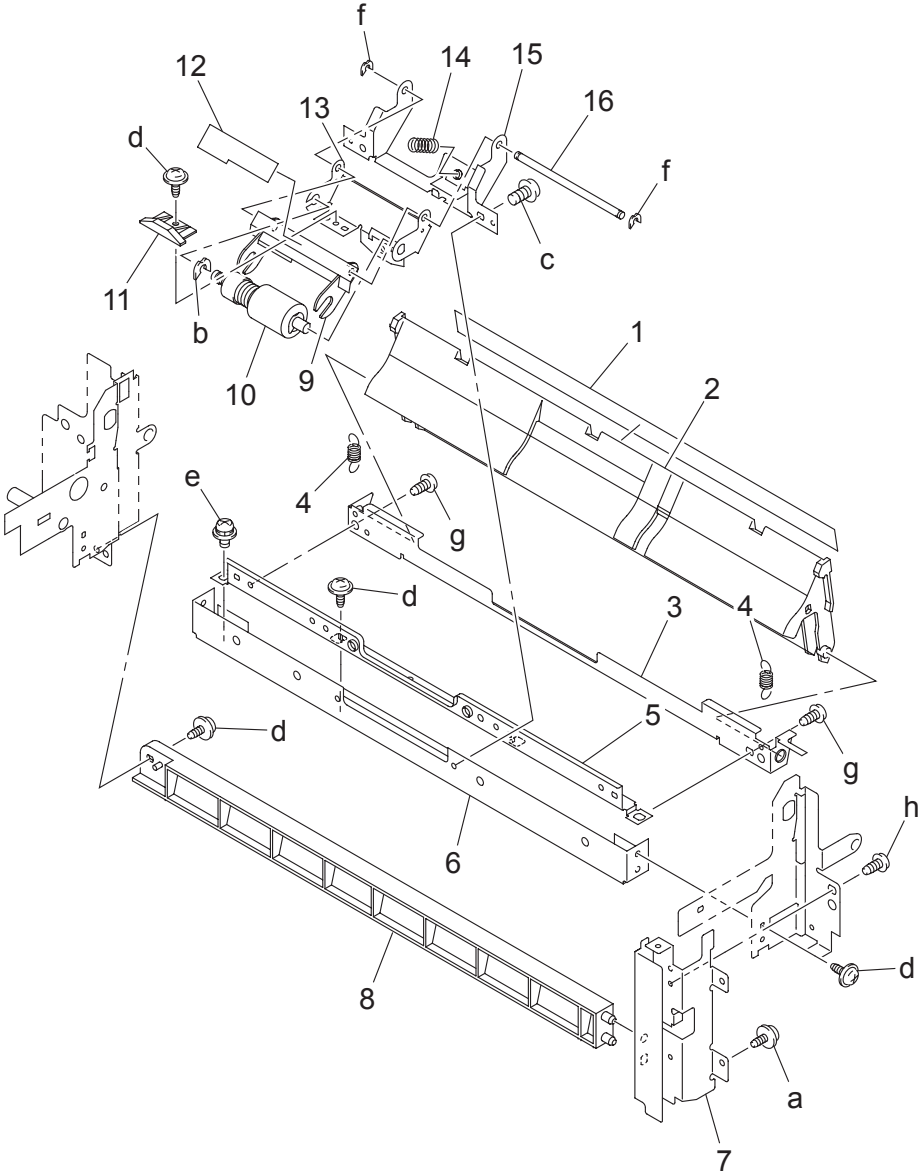



CASSETTE FRAME

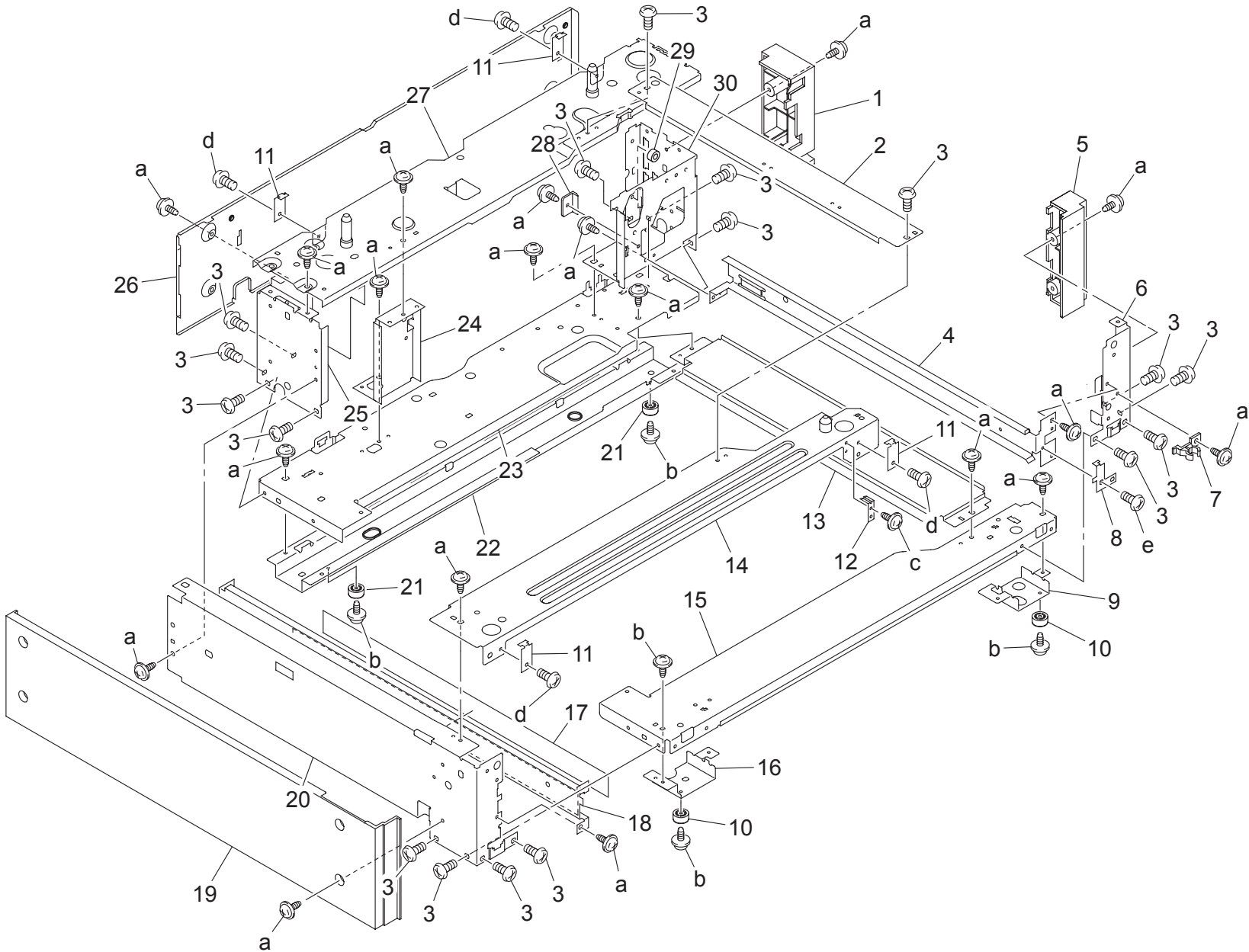



CASSETTE DRIVE SECTION

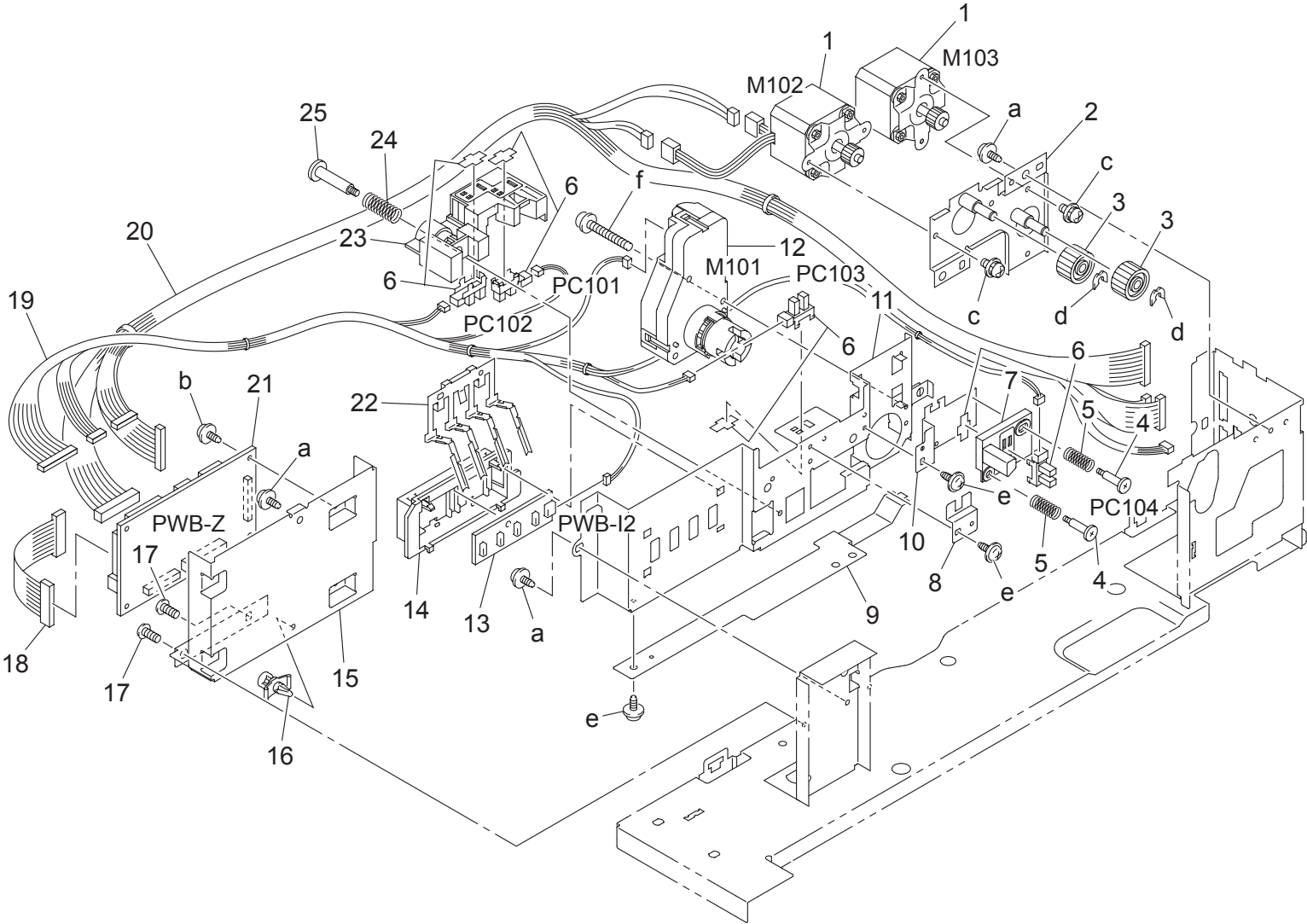



CASSETTE DRIVE SECTION

Key	Part No.	Description	Destinations	Class	QTY	Standard parts
1	9314 1300 61	MOTOR		B	2	a-9735 0408 14
2	4348 0202 01	FRAME ASSY		D	1	b-9735 0308 14
3	4348 3030 01	GEAR 27T		C	2	c-9646 0306 14
4	4030 3224 01	SHOULDER SCREW		C	2	d-4425 3001 01
5	4030 3081 01	PRESSURE SPRING		C	2	e-9735 0306 14
6	4037 0906 01	PHOTO INTERRUPTER		B	4	f-9646 0330 14
6	4537 0901 01	PHOTO INTERRUPTER		B	4	
7	4030 3083 01	HOLDER		D	1	
8	4030 3048 02	BRACKET		D	1	
9	4030 3049 01	BRACKET		D	1	
10	4030 3208 02	BRACKET		D	1	
11	4030 3046 03	BRACKET		D	1	
12	9312 1200 31	MOTOR		B	1	
13	4011 0111 01	PWB-I		C	1	
14	4011 3012 01	HOLDER		D	1	
15	4036 3815 01	BRACKET		D	1	
16	9384 1621 21	PWB SUPPORT 6.4H		D	1	
17	4002 2581 01	SCREW		C	2	
18	4036 6826 01	WIRE HARNESS ASSY		D	1	
19	4036 6829 01	WIRE HARNESS ASSY		D	1	
20	4036 6825 02	WIRE HARNESS ASSY		D	1	
21	4036 0132 02	PWB-Z		I	1	
22	4030 3091 01	LEVER		C	1	
23	4030 3047 02	HOLDER		D	1	
24	4002 3110 01	PRESSURE SPRING		C	1	
25	4002 3131 01	SHOULDER SCREW		C	1	

FUSING SECTION

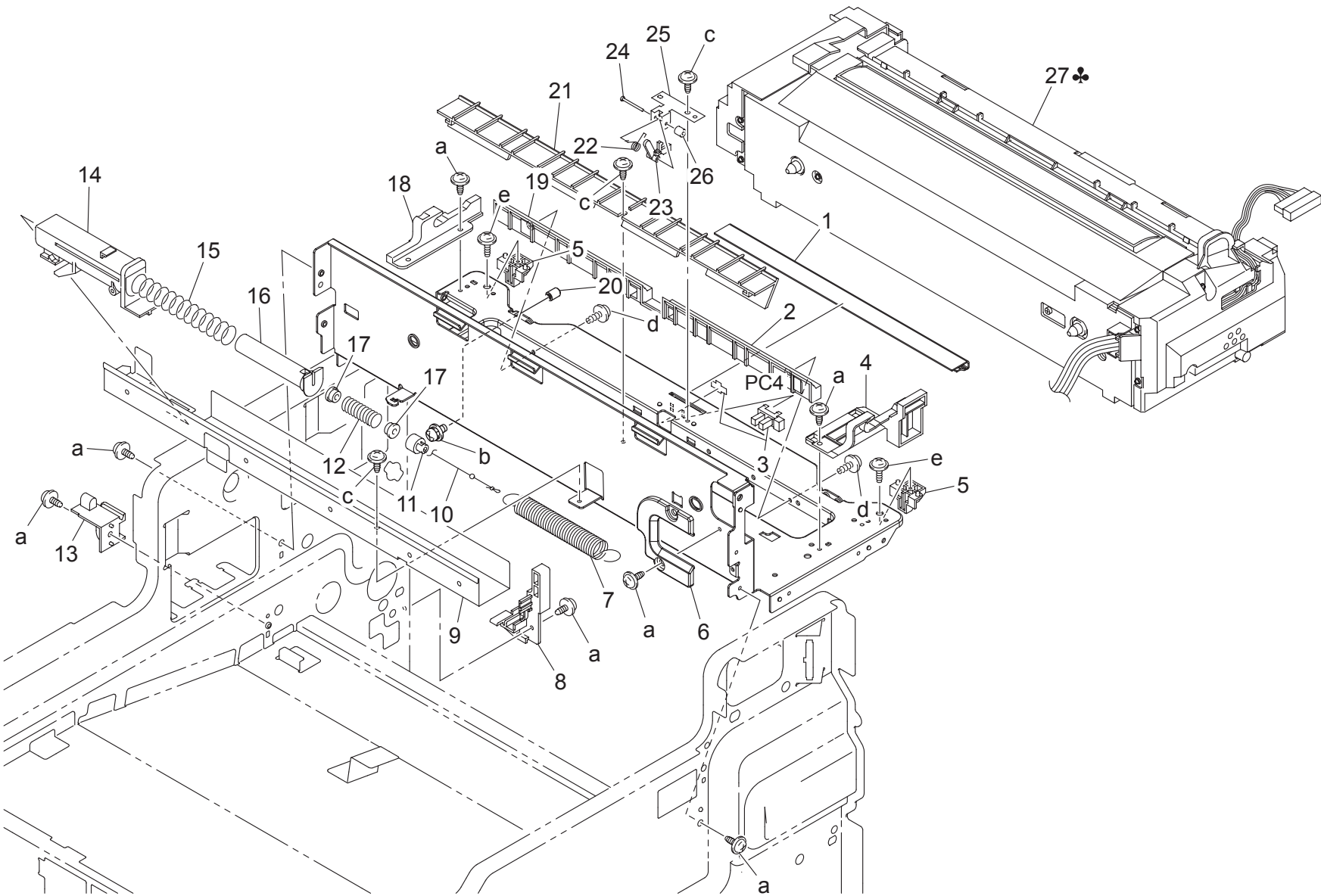

FUSING SECTION

Key	Part No.	Description	Destinations	Class	QTY	Standard parts
1	4036 2009 01	SEAL		D	1	a-9735 0308 14 b-9646 0308 14 c-9735 0306 14 d-9739 0306 14 e-9739 0308 14
2	4036 3667 02	GUIDE		D	1	
3	4037 0903 01	PHOTO INTERRUPTER		B	1	
4	4036 2070 01	GUIDE		D	1	
5	4036 3656 01	PAWL		D	2	
6	4036 2008 01	GUIDE		D	1	
7	4036 3583 01	TENSION SPRING		C	1	
8	4036 3518 02	GUIDE		D	1	
9	4036 3530 02	BRACKET		D	1	
10	4036 3511 01	WIRE		C	1	
11	4004 3512 02	FLANGE		D	1	
12	4036 3682 01	PRESSURE SPRING		D	1	
13	4004 3516 02	GUIDE		D	1	
14	1164 2047 03	FLANGE		D	1	
15	4036 3658 01	PRESSURE SPRING		D	1	
16	1164 2046 01	FLANGE		D	1	
17	4036 3681 01	COLLAR		C	2	
18	4036 2071 01	GUIDE		D	1	
19	4036 3663 02	GUIDE		D	1	
20	4037 2010 01	SHAFT		D	1	
21	4036 3668 01	GUIDE		D	1	
22	4036 3664 01	TORSION SPRING		C	1	
23	4036 3661 02	ACTUATOR		C	1	
24	1200 5211 08	PIN		D	1	
25	4036 3662 02	HOLDER		D	1	
26	1200 2105 07	COLLAR		D	1	
27	4049 521	FUSING UNIT 100V	定着ユニット 100V	A	1	
27	4049 522	FUSING UNIT 220-240V	定着ユニット 220-240V	C,J,D,F2,G1,I,K	1	
27	4049 523	FUSING UNIT 120-127V	定着ユニット 120-127V	B,G2,F1	1	
27	4049 524	FUSING UNIT 110V	定着ユニット 110V	H	1	

PAPER DETECT SECTION

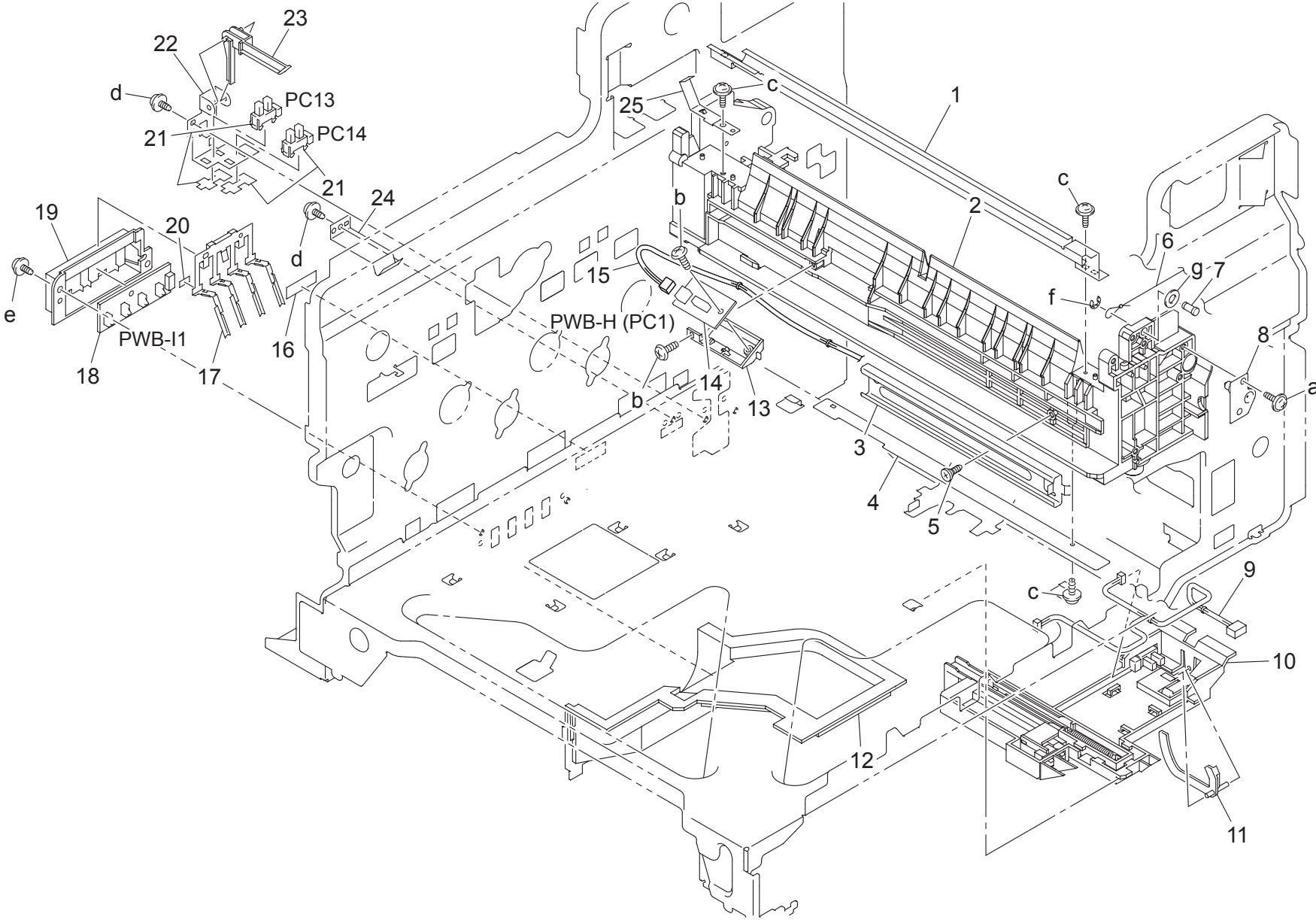



PAPER DETECT SECTION

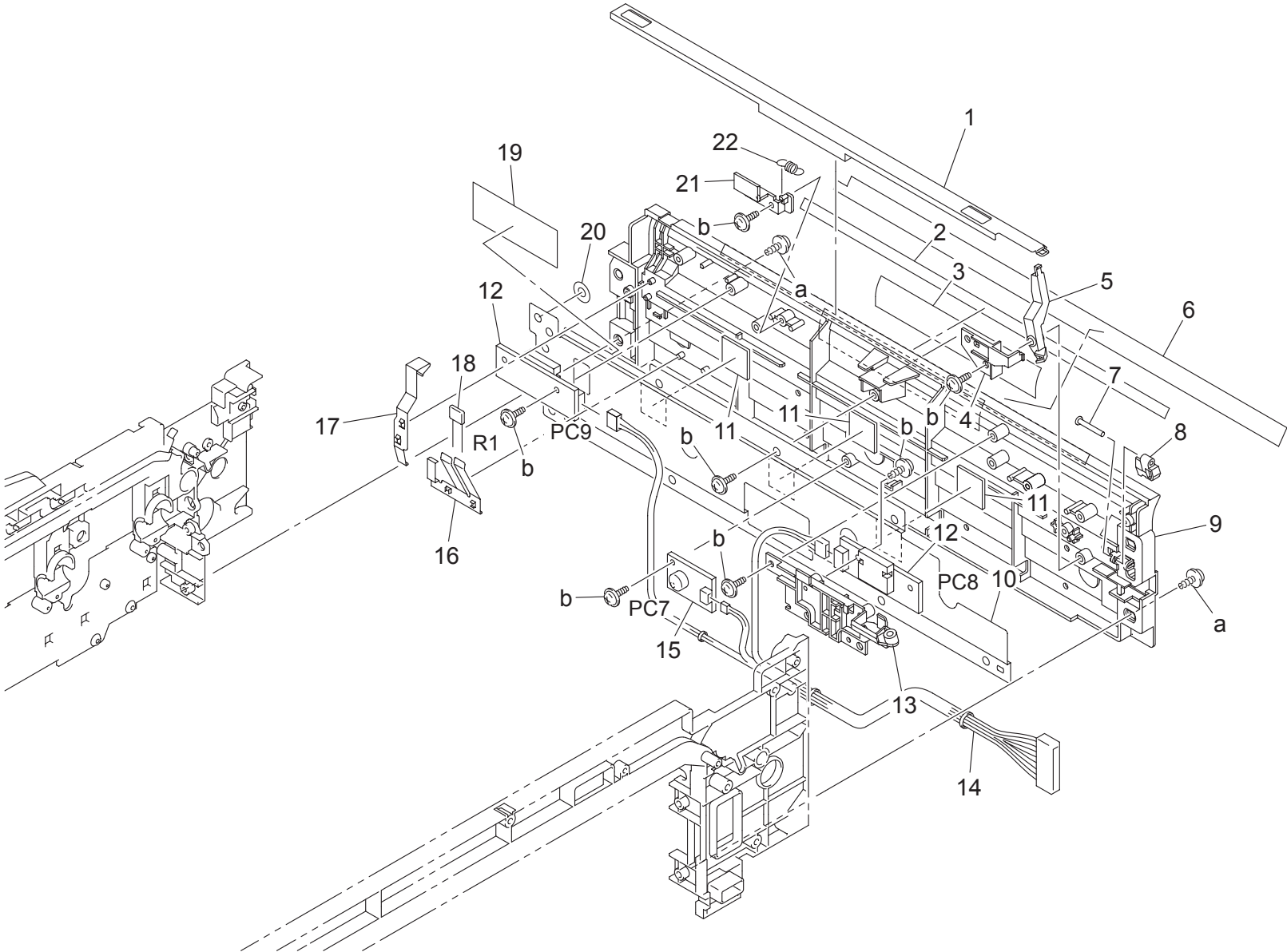

PAPER DETECT SECTION

Key	Part No.	Description	Destinations	Class	QTY	Standard parts
1	4036 3555 01	SHUTTER		D	1	a-9739 0408 14 b-9739 0308 14
2	4036 3643 01	SEAL		D	1	
3	4036 3531 01	SEAL		D	1	
4	4025 3674 02	HOLD PLATE		D	1	
5	4025 3558 01	LEVER		C	1	
6	4025 3533 02	SEAL		D	1	
7	4025 3676 01	PIN		D	1	
8	4036 3673 01	LEVER		C	1	
9	4036 3507 04	GUIDE		D	1	
10	4036 3587 01	SHIELD		D	1	
11	4036 3671 01	SPACER		D	3	a-9739 0408 14 b-9739 0308 14
12	9372 1300 12	PHOTO SENSING ELEMENT		B	2	
13	4036 3540 01	COVER		D	1	
14	4037 6813 01	WIRE HARNESS ASSY		D	1	
15	9372 5400 11	HUMIDITY CONVERSION EL.		C	1	
16	4036 3641 02	CONTACT		D	1	
17	4025 3642 01	CONTACT		C	1	
18	9454 4076 02	RESISTOR		D	1	
19	4036 3645 01	COVER		D	1	
20	4036 3649 01	SPACER		D	1	
21	4036 3557 01	STOPPER		D	1	a-9739 0408 14 b-9739 0308 14
22	4025 3556 01	TENSION SPRING		C	1	

TRANSFER SECTION

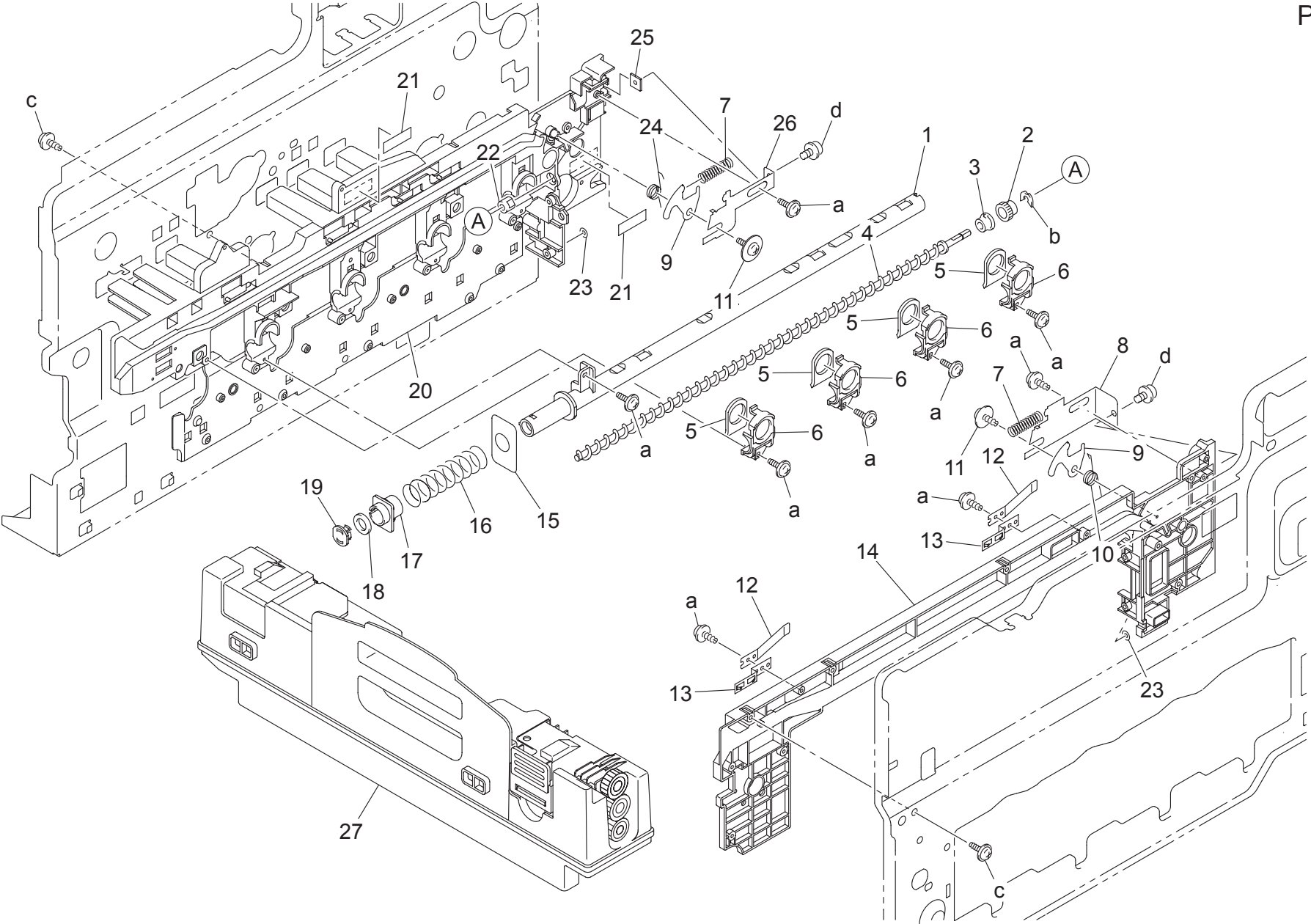



TRANSFER SECTION

Key	Part No.	Description	Destinations	Class	QTY	Standard parts
1	4004 5601 02	PIPE		D	1	a-9739 0308 14 b-4425 3001 01 c-9739 0408 14 d-9646 0408 14
2	4036 5612 01	GEAR 18T	ギヤ 18 T	C	1	
3	4004 5607 02	BUSHING	軸受	C	1	
4	4036 5606 01	SCREW	搬送羽根	D	1	
5	4004 5605 01	SEAL	シール	C	4	
6	4004 5604 01	JOINT	ジョイント	D	4	
7	4004 4546 02	PRESSURE SPRING	圧縮コイルばね	C	2	
8	4036 4904 01	BRACKET	取付板	D	1	
9	4036 4543 01	LEVER	レバー	C	2	
10	4004 4544 02	TORSION SPRING	ねじりコイルばね	C	1	
11	4036 5966 01	SCREW	ねじ	C	2	
12	4004 4553 01	PLATE SPRING	板ばね	D	2	
13	4036 4550 01	CONTACT	接点	D	2	
14	4036 4541 01	RAIL	レール	D	1	
15	4025 5614 01	SEAL	シール	C	1	
16	4004 5610 01	PRESSURE SPRING	圧縮コイルばね	C	1	
17	4004 5609 01	SHUTTER	シャッター	D	1	
18	4004 5613 01	SEAL	シール	C	1	
19	4004 5611 01	LID	蓋	D	1	
20	4036 4542 01	RAIL	レール	D	1	
21	1129 7303 01	LABEL HI-VOL CAUTION	ラベル 高圧注意	D	2	
22	4036 5615 01	BUSHING	軸受	C	1	
23	4036 3672 01	SPACER	スペーサ	D	2	
24	4004 4555 02	TORSION SPRING	ねじりコイルばね	C	1	
25	4036 4909 01	PLATE NUT	板ナット	D	1	
26	4036 4545 01	BRACKET	取付板	D	1	
27	4049 111	WASTE TONER BOTTLE	廃棄トナーボトル	A	1	

TRANSFER FRAME

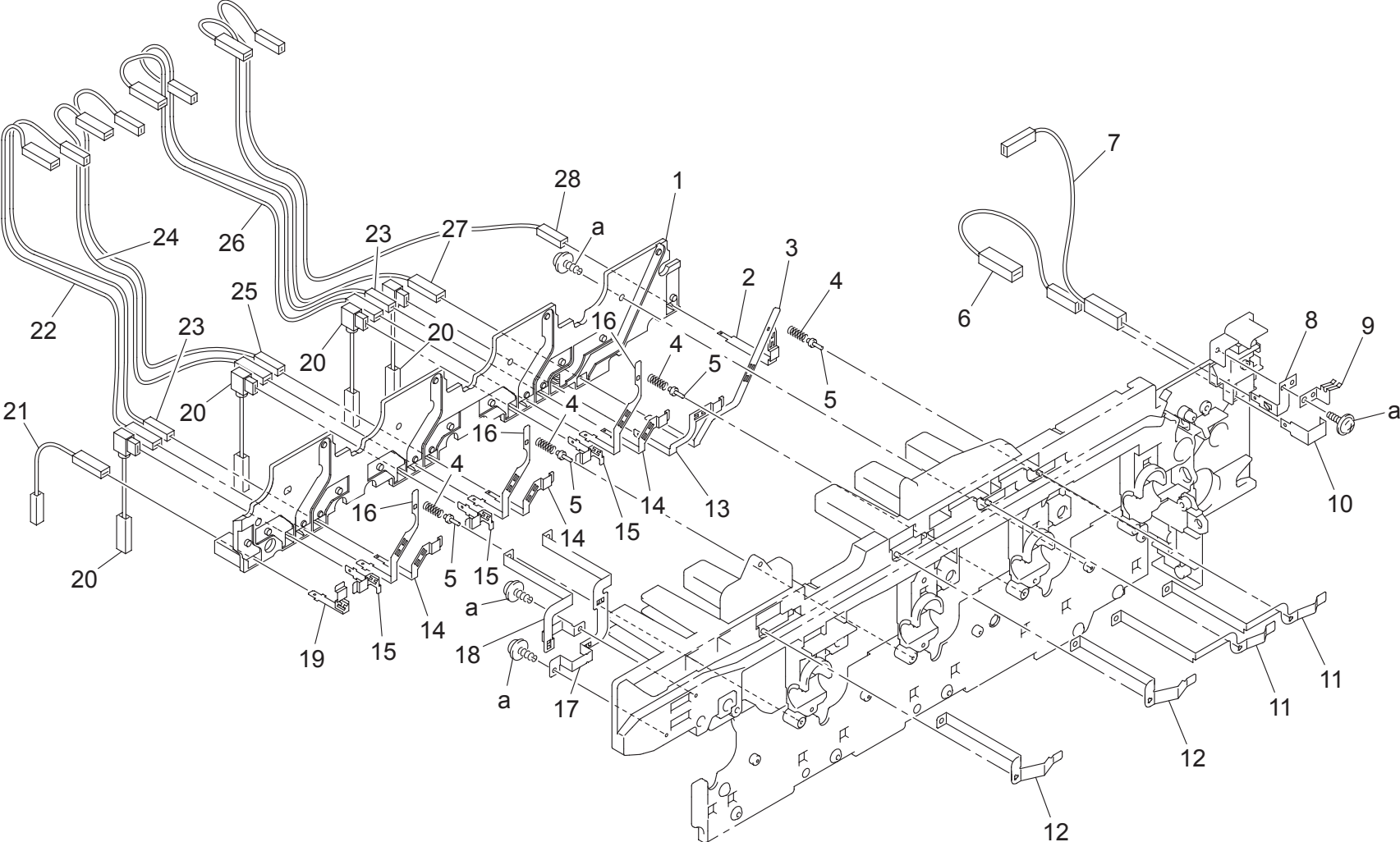



# TRANSFER BELT UNIT

改訂版 REVISED EDITION	日付 DATE
	APRIL 2005

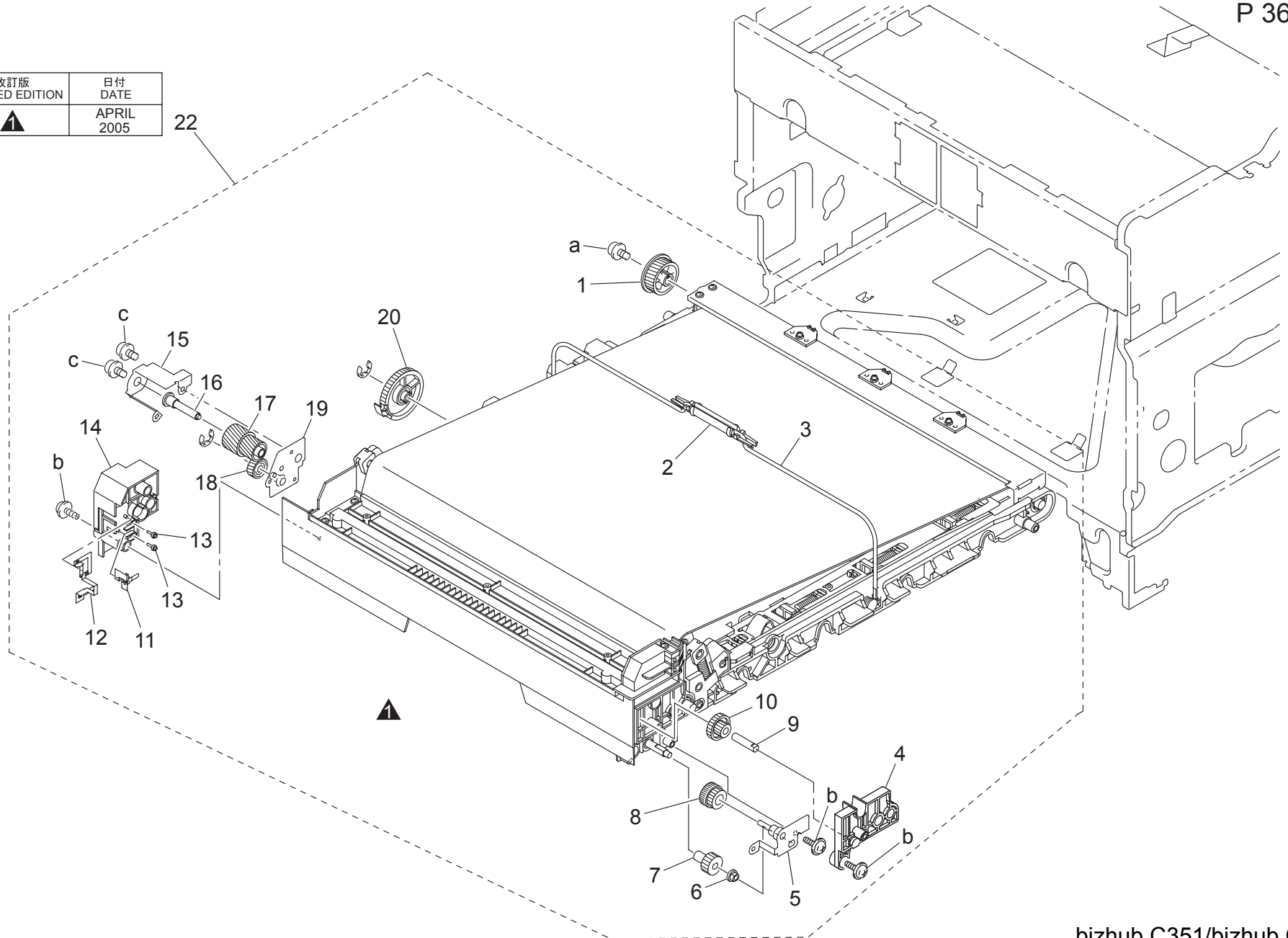



# LED UNIT

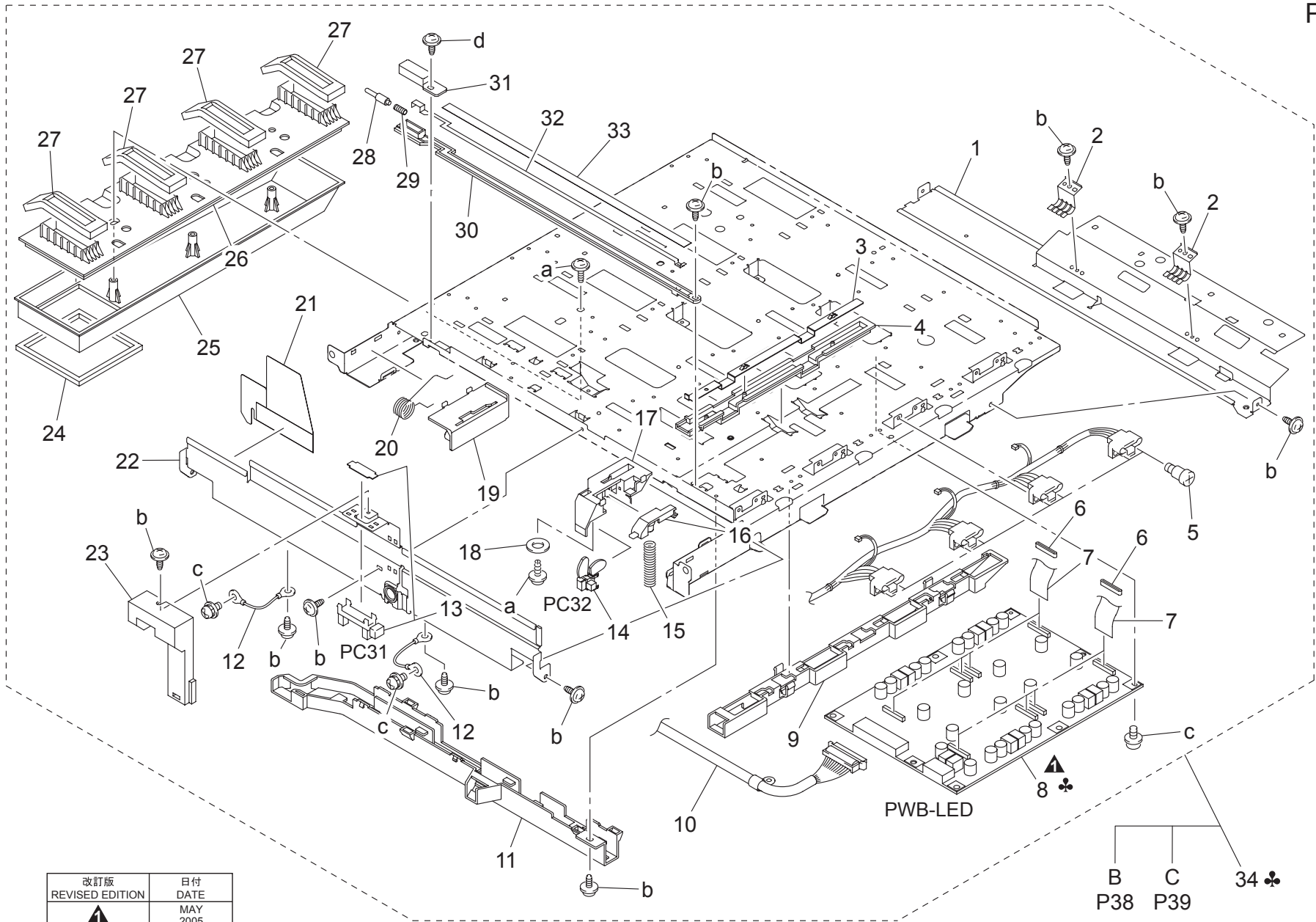

改訂版 REVISED EDITION	日付 DATE
	MAY 2005

B P38  
C P39  
34 ♣

Key	Part No.	Description	Destinations	Class	QTY	Standard parts
1	4036 2224 02	BASE FRAME	台板	D	1	a-9739 0306 14 b-9735 0306 14 c-9646 0306 14 d-9735 0308 14
2	4004 2234 01	EARTH GROUND	アース	D	2	
3	4025 5290 01	CONTACT	接点	D	1	
4	4025 5294 01	HOLDER	ホルダ	D	1	
5	1079 2219 01	SHOULDER SCREW	段ねじ	C	8	
6	9326 1200 21	FERRITE CORE	フェライトコア	D	8	
7	4036 6835 01	WIRE HARNESS ASSY	ハーネス ASSY	D	8	
8	4037 0105 01	PWB-LED	PWB-LED	C	1	
8	4036 0105 02	PWB-LED	PWB-LED	I	1	
9	4025 1840 01	GUIDE	ガイド	D	1	
10	4037 6823 01	WIRE HARNESS ASSY	ハーネス ASSY	D	1	
11	4025 1841 01	GUIDE	ガイド	D	1	
12	4004 6854 01	WIRE HARNESS ASSY	ハーネス ASSY	D	2	
13	4037 0901 01	PHOTO INTERRUPTER	フォトインタラプター	B	1	
14	9332 1910 21	PUSHBUTTON SWITCH	押釦スイッチ	C	1	
15	4025 2273 01	PRESSURE SPRING	圧縮コイルばね	C	1	
16	4025 2272 01	LIFTING PLATE	押上板	D	1	
17	4025 2221 01	COVER	カバー	D	1	
18	4004 2222 01	WASHER	ワッシャ	C	1	
19	4025 2228 01	COVER	カバー	D	1	
20	4025 2274 01	TORSION SPRING	ねじりコイルばね	D	1	
21	4025 2250 01	SEAL	シール	D	1	
22	4036 2226 01	BRACKET	取付板	D	1	
23	4004 2227 03	COVER	カバー	D	1	
24	4004 2144 01	SEAL	シール	D	1	
25	4025 2147 01	DUCT	ダクト	D	1	
26	4025 2150 01	DUCT	ダクト	D	1	
27	4025 1812 01	SEAL	シール	C	4	
28	4036 2425 01	PIN	ピン	D	1	
29	4004 2317 01	PRESSURE SPRING	圧縮コイルばね	C	1	
30	4036 5291 01	HOLDER	ホルダ	D	1	
31	4036 2426 01	HOLDER	ホルダ	D	1	
32	4036 5288 01	CONTACT	接点	D	1	
33	4004 2155 01	SEAL	シール	D	1	
34	4037 0763 00	LED UNIT	LED ユニット	A,F1(bizhub C450)	I	1
34	4037 0764 00	LED UNIT	LED ユニット	C,J,D,F2,G1,I,K,H(bizhub C450)	I	1
34	4037 0764 00	LED UNIT	LED ユニット	B,G2	I	1
34	4037 0560 01	LED UNIT	LED ユニット	A,F1(bizhub C351)	I	1
34	4037 0561 01	LED UNIT	LED ユニット	B,G2(bizhub C351)	I	1
34	4037 0561 01	LED UNIT	LED ユニット	C,J,D,F2,G1,I,K,H(bizhub C351)	I	1

# LED UNIT

改訂版 REVISED EDITION	日付 DATE
	MAY 2005

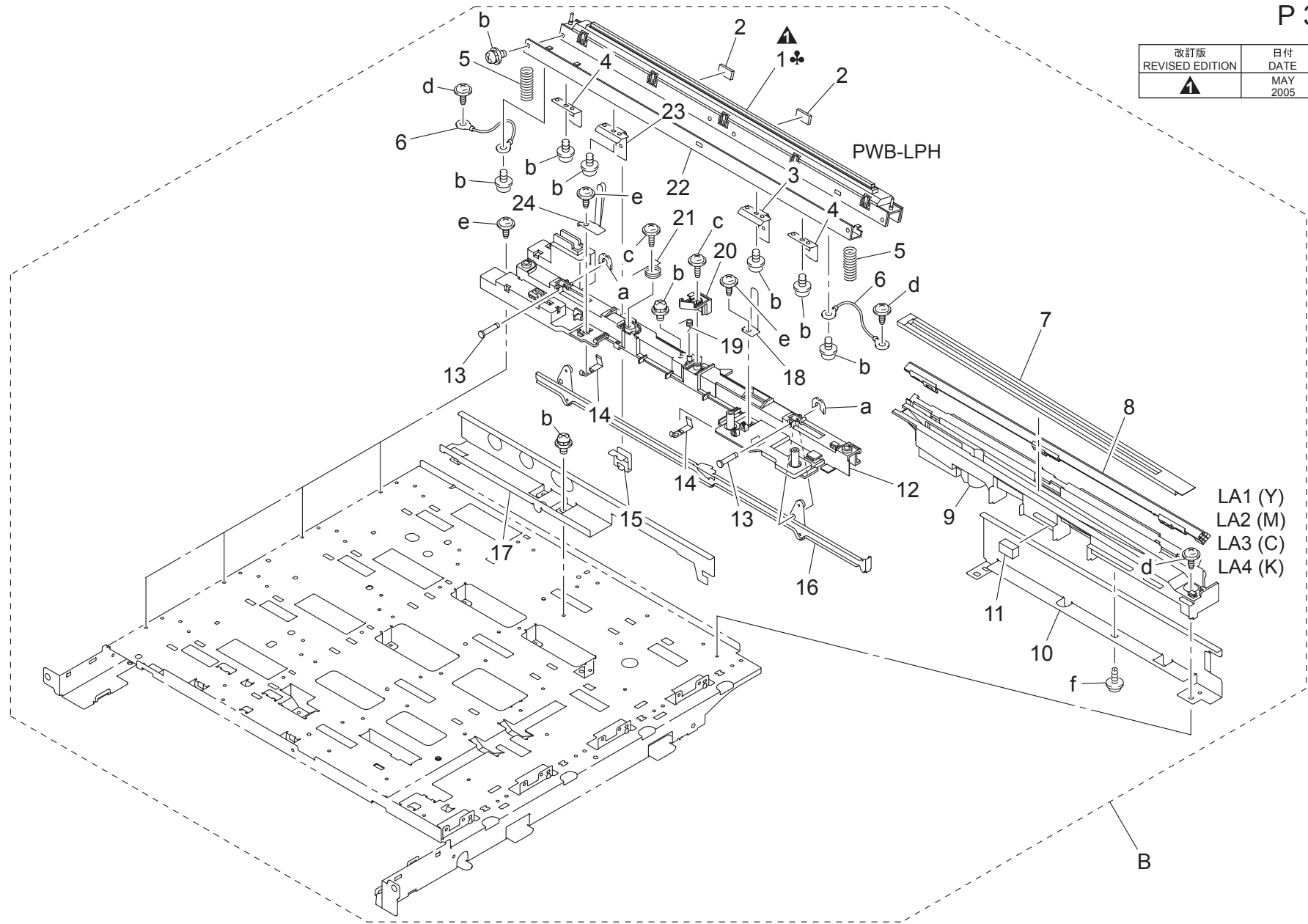



Key	Part No.	Description	Destinations	Class	QTY	Standard parts	
1	4037 0765 00	LPH-BLACK ASSY	L P H ( B K ) A S S Y	(BLACK,bizhub C450)	I	1	a-4425 3002 01
1	4037 0766 00	LPH-YMC ASSY	L P H ( Y M C ) A S S Y	(YMC,bizhub C450)	I	3	b-9646 0306 14
1	4036 0564 01	LPH-YMC ASSY	L P H ( Y M C ) A S S Y	(YMC,bizhub C351)	I	3	c-9739 0306 14
1	4036 0563 01	LPH-BLACK ASSY	L P H ( B K ) A S S Y	(BLACK,bizhub C351)	I	1	d-9735 0306 14
2	4025 2175 01	CUSHION	クッション		D	8	e-9735 0308 14
3	4036 1815 01	GUIDE	ガイド		D	4	f-9739 0308 14
4	4036 1704 01	BRACKET	取付板		D	8	
5	4004 1807 01	PRESSURE SPRING	圧縮コイルばね		C	8	
6	4004 6854 01	WIRE HARNESS ASSY	ハーネス A S S Y		D	8	
7	4025 2172 02	SEAL	シール		D	4	
8	4036 6062 01	ERASE ASSY	イレース A S S Y	(YMC)	C	3	
8	4037 6061 01	ERASE ASSY	イレース A S S Y	(BLACK)	C	1	
9	4025 2171 01	DUCT	ダクト		D	4	
10	4025 2151 01	GUIDE	ガイド		D	4	
11	4036 2176 01	CUSHION	クッション		D	4	
12	4036 1701 01	FRAME	フレーム		D	4	
13	4004 1805 01	SHAFT	シャフト		D	8	
14	4004 1719 01	PLATE SPRING	板ばね		D	8	
15	4004 1712 01	GUIDE	ガイド		D	4	
16	4025 1702 03	ARM	アーム		D	4	
17	4025 2152 01	GUIDE	ガイド		D	4	
18	4025 1716 01	PLATE SPRING	板ばね		D	4	
19	4004 1819 02	TORSION SPRING	ねじりコイルばね		D	4	
20	4025 1813 02	LEVER	レバー		D	4	
21	4025 1703 01	TORSION SPRING	ねじりコイルばね		D	4	
22	4036 1705 01	BRACKET	取付板		D	4	
23	4036 1814 01	GUIDE	ガイド		D	4	
24	4025 1720 02	PLATE SPRING	板ばね		D	8	

LED UNIT

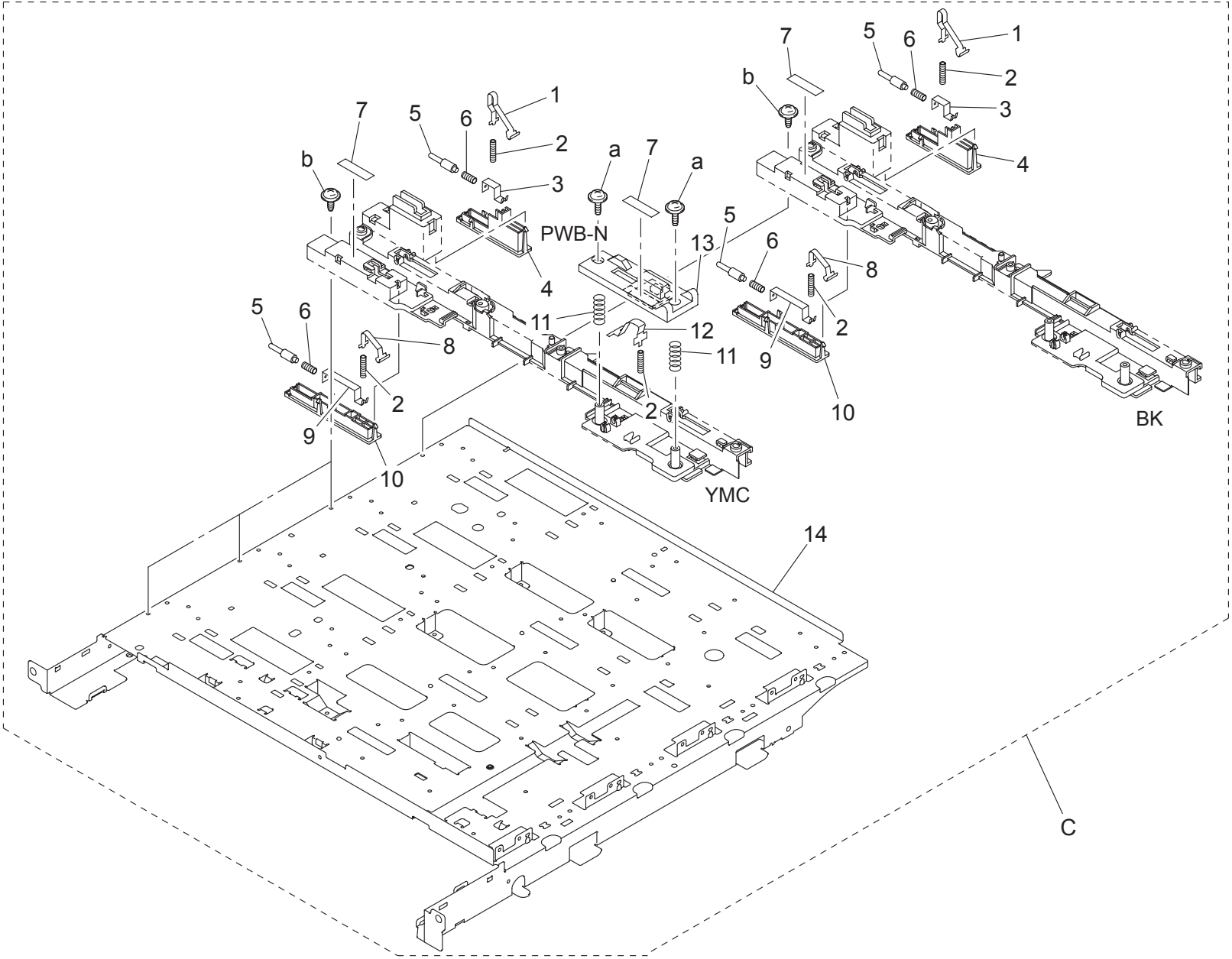

Key	Part No.	Description	Destinations	Class	QTY	Standard parts
1	4025 2422 01	CONTACT		C	4	a-9739 0306 14 b-9735 0308 14
2	4004 5283 01	PRESSURE SPRING		C	11	
3	4036 2424 01	CONTACT		D	4	
4	4036 2406 01	HOLDER		D	4	
5	4036 2425 01	PIN		D	8	
6	4004 2317 01	PRESSURE SPRING		C	8	
7	1129 7303 01	LABEL HI-VOL CAUTION		D	7	
8	4004 2401 01	CONTACT		C	4	
9	4036 2404 01	CONTACT		D	4	
10	4036 2405 01	HOLDER		D	4	
11	4004 5282 01	PRESSURE SPRING		C	6	
12	4004 5287 01	CONTACT		D	3	
13	4004 0105 05	PWB ASSY		C	3	
14	4036 2223 01	BASE FRAME		D	1	

FUSING COOL SECTION

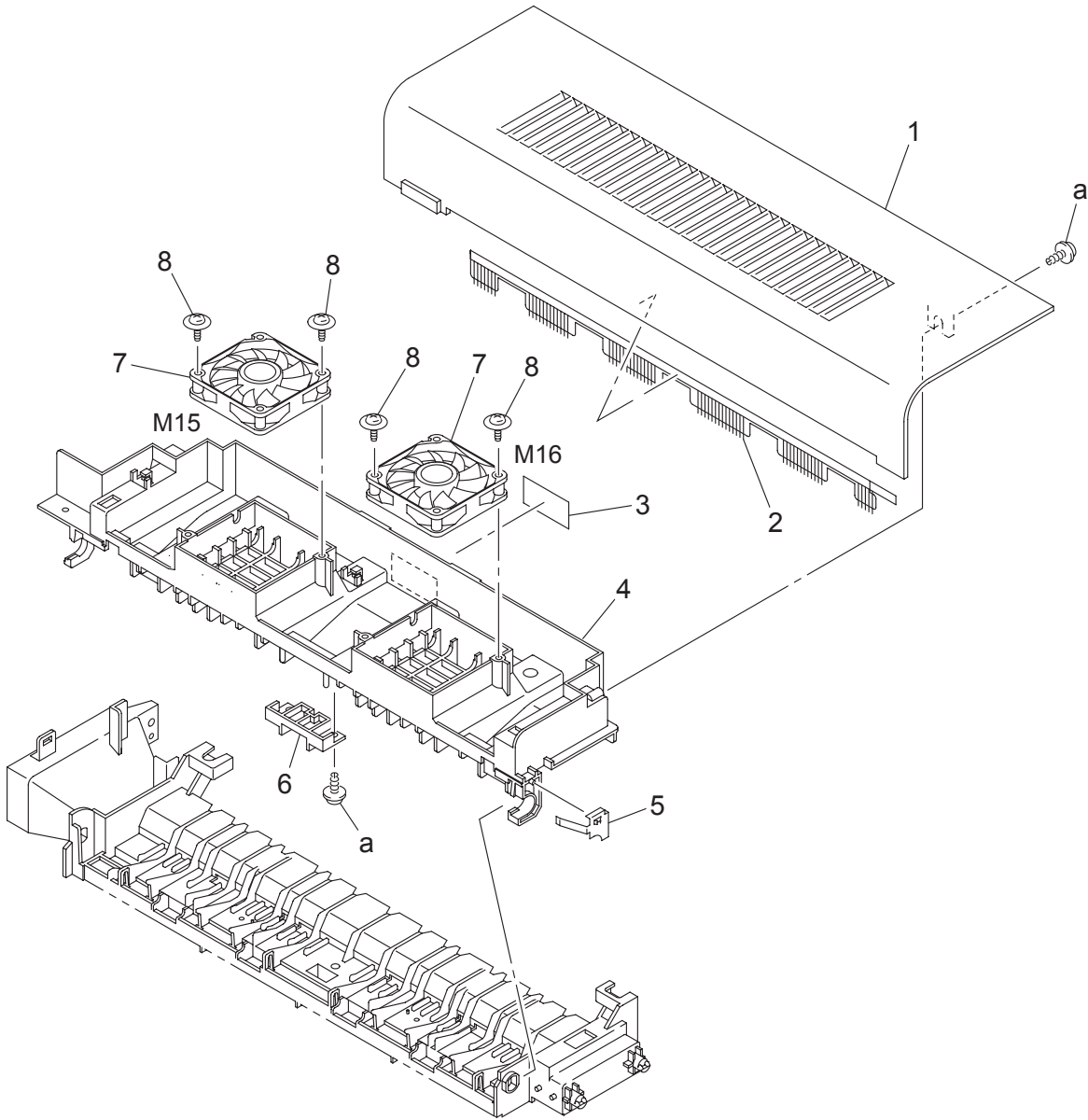



PAPER EXIT DRIVE SECTION

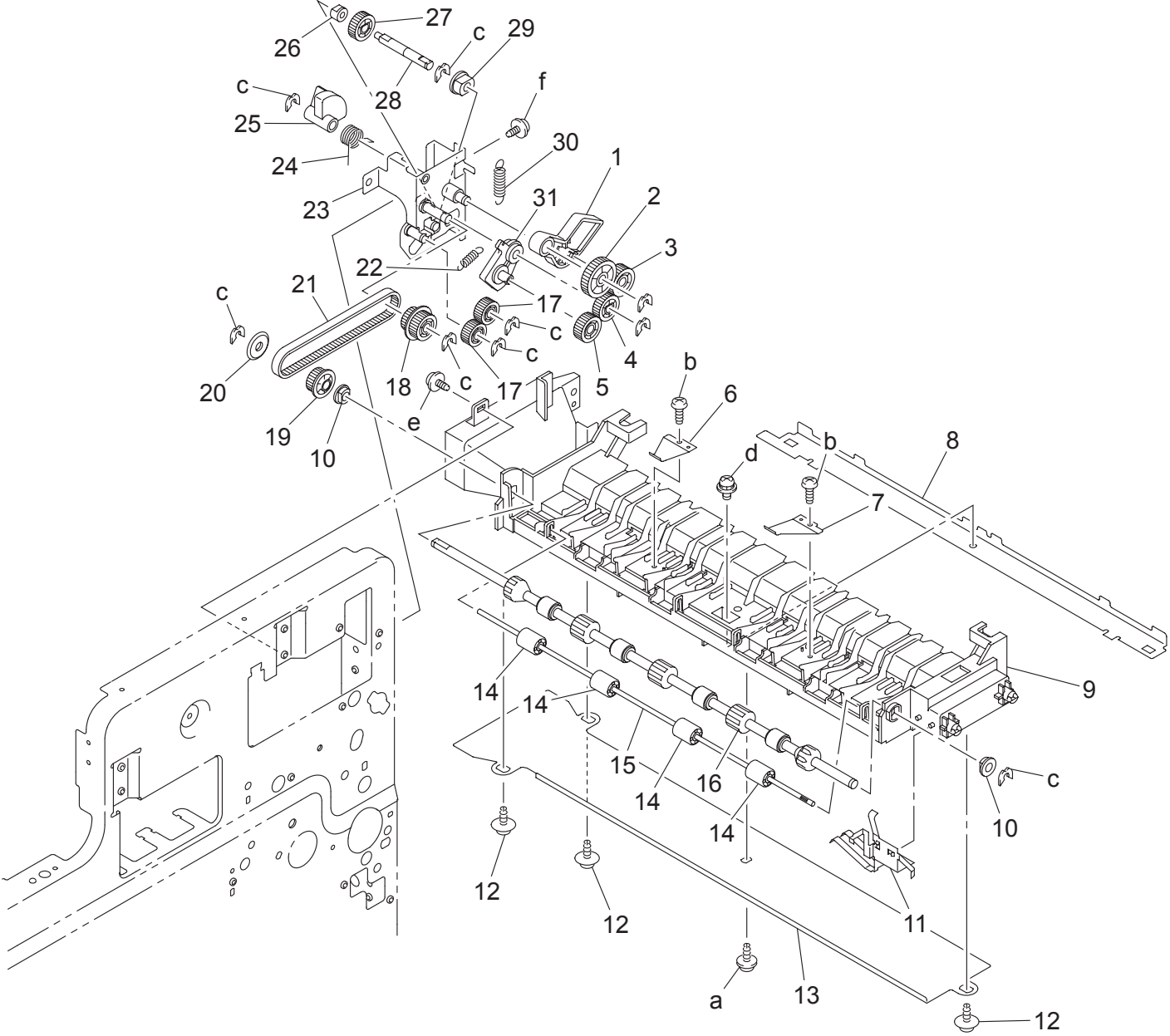



PAPER TRANSPORT SECTION

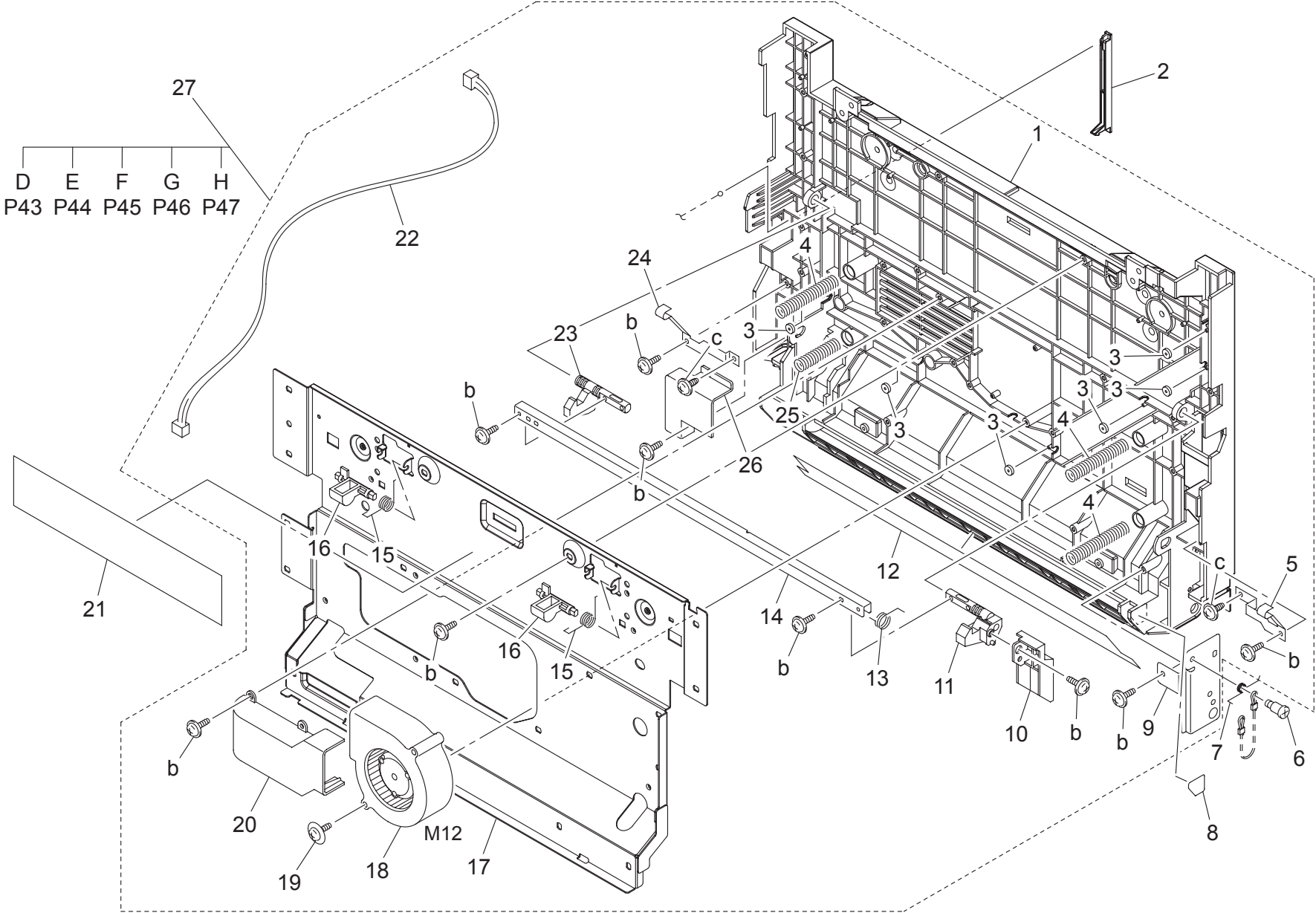





PAPER TRANSPORT SECTION

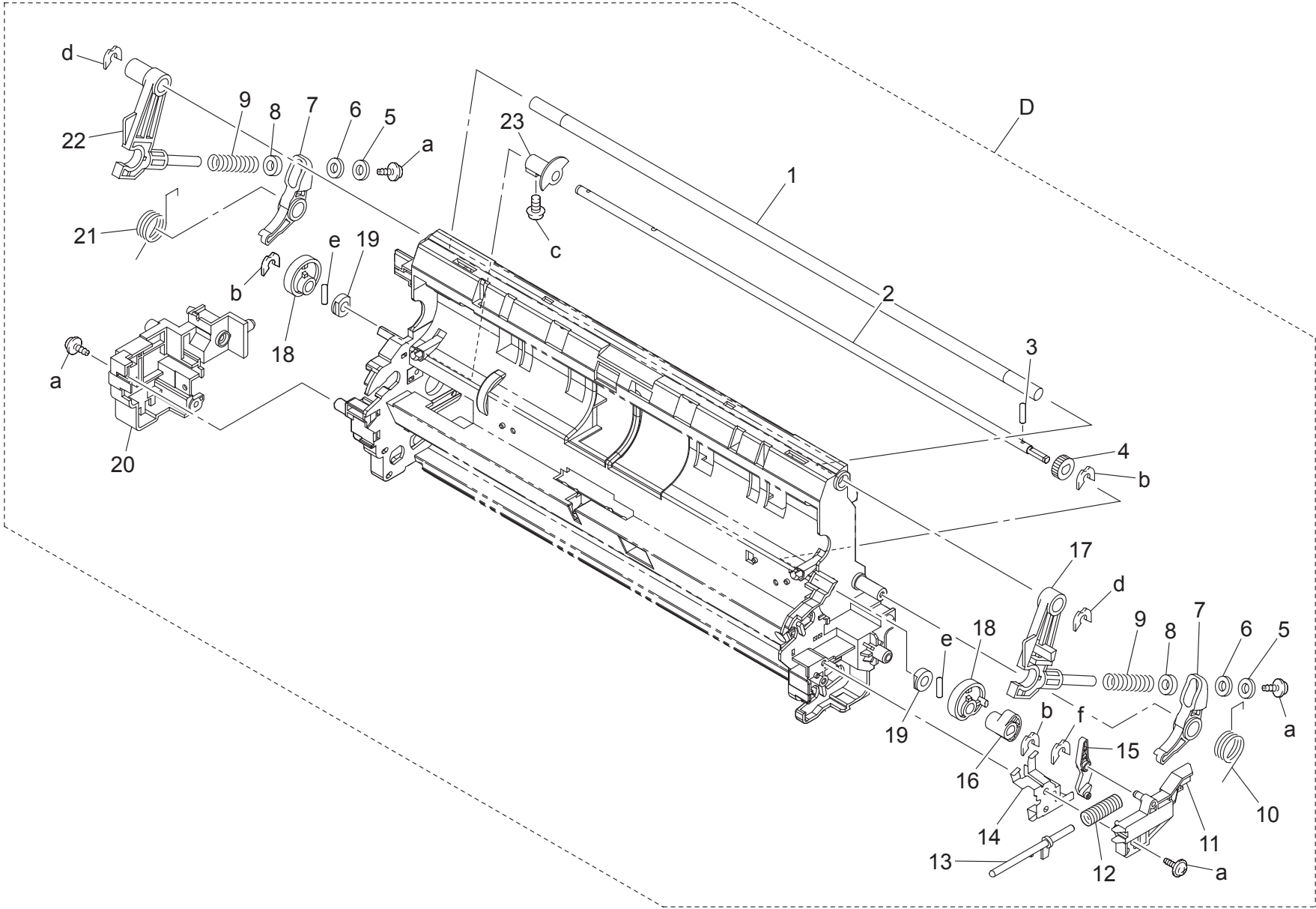



PAPER TRANSPORT SECTION

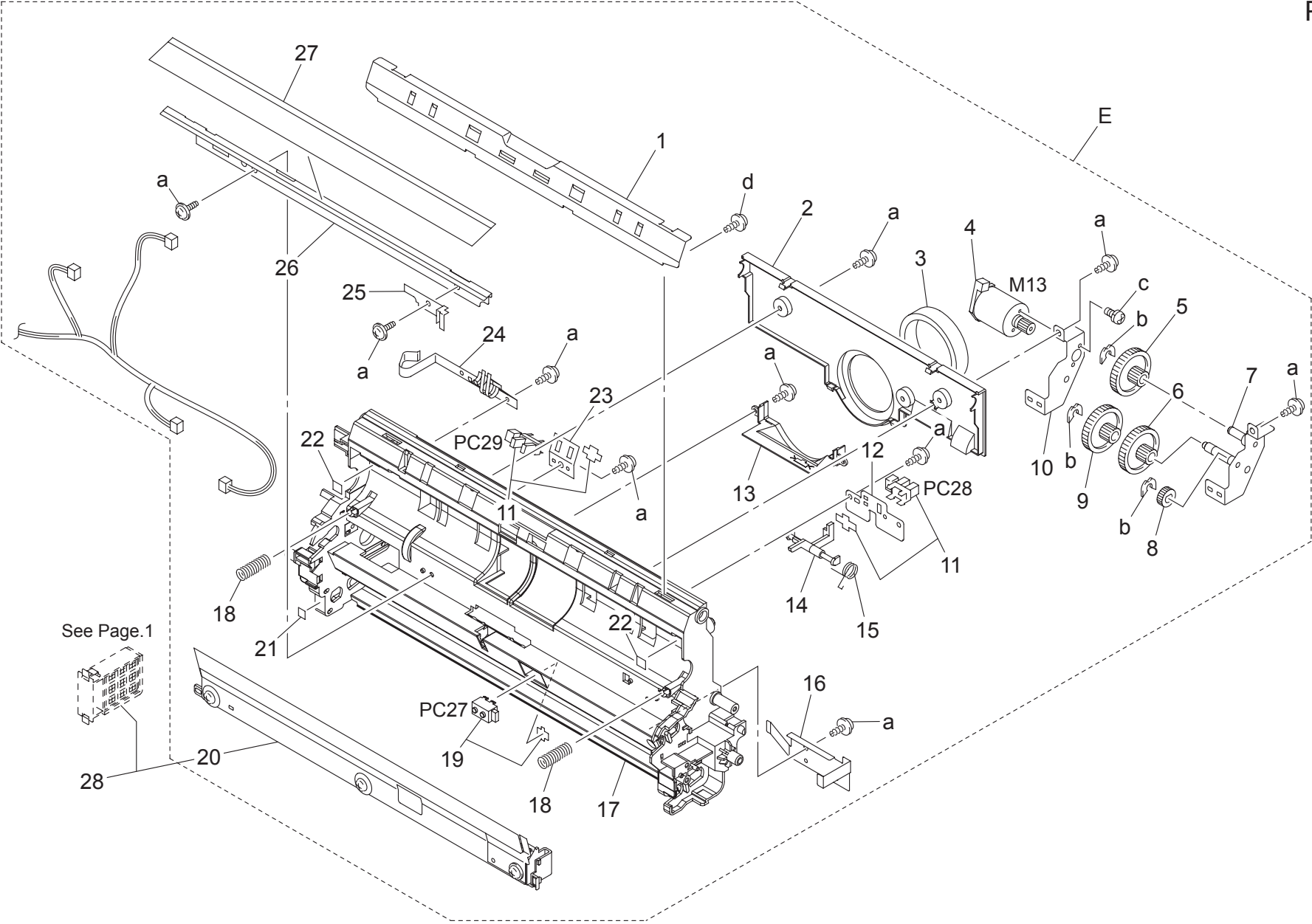



PAPER TRANSPORT SECTION

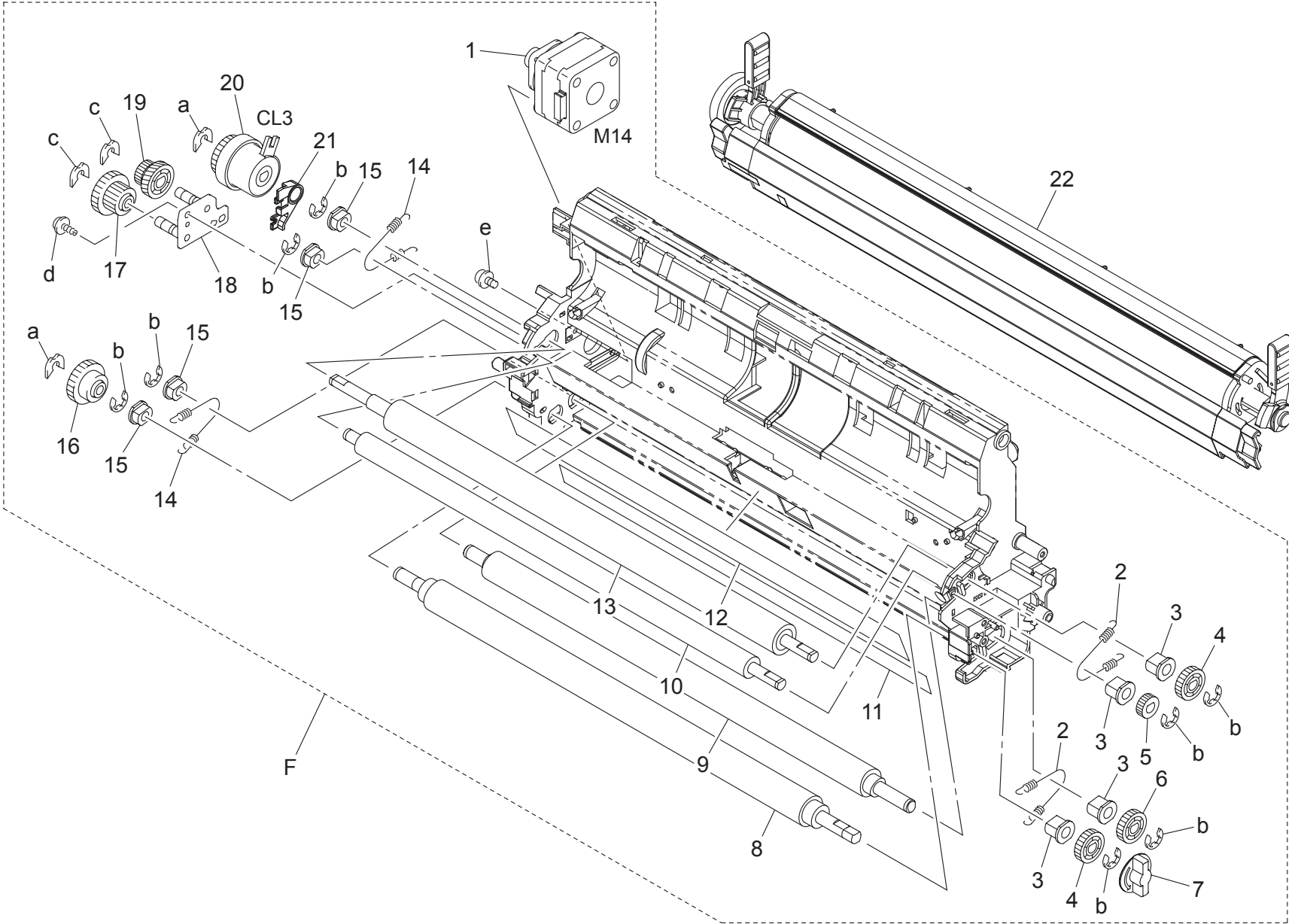

PAPER TRANSPORT SECTION

Key	Part No.	Description	Destinations	Class	QTY	Standard parts
1	9314 1300 31	MOTOR		B	1	a-1066 1151 01 b-9721 0600 01 c-4425 3001 01 d-9739 0308 14 e-9646 0306 14
2	4025 3527 01	TENSION SPRING		D	2	
3	4025 3572 01	BUSHING		D	4	
4	4004 3503 02	GEAR 20T		D	2	
5	4004 3504 02	GEAR 14T		D	1	
6	1164 3508 01	GEAR 18T		B	1	
7	4025 3631 02	KNOB		C	1	
8	4025 3621 01	ROLLER		C	1	
9	4025 3622 01	ROLLER		C	1	
10	4025 3502 01	ROLLER		C	1	
11	4036 3608 01	SEAL		D	1	
12	4025 3609 01	SEAL		C	1	
13	4037 3501 01	ROLLER		C	1	
14	4025 3623 01	TENSION SPRING		D	2	
15	1164 3509 01	BUSHING		C	4	
16	4025 3625 01	GEAR 28T		D	1	
17	4025 3627 01	GEAR 16/38T		D	1	
18	4025 0221 01	BRACKET ASSY		D	1	
19	4025 3626 01	GEAR 18/26T		D	1	
20	9322 1400 11	CLUTCH		C	1	
21	4037 3685 01	GUIDE		D	1	
22	4049 411	TRANSFER ROLLER UNIT		A	1	

PAPER TRANSPORT SECTION

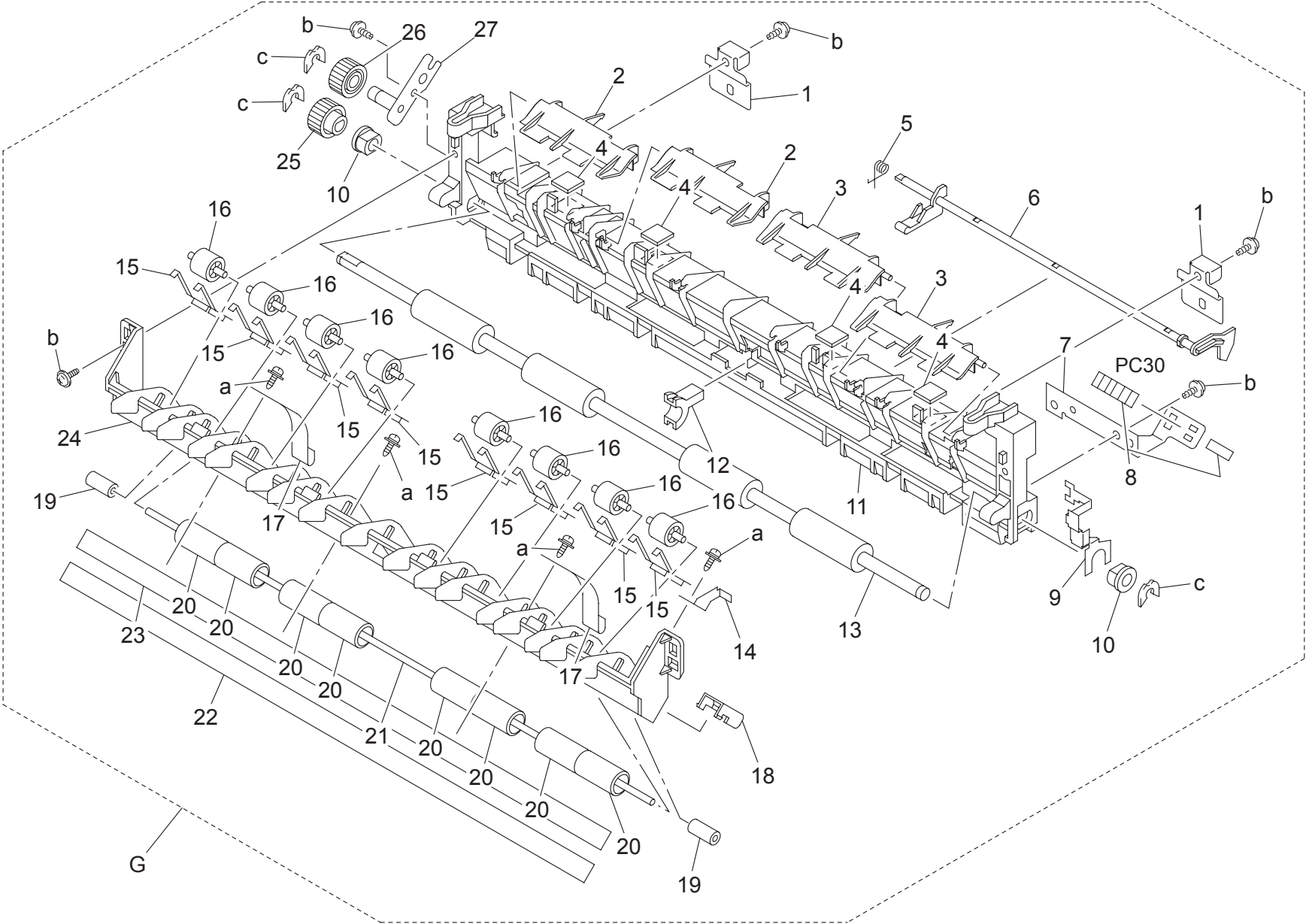





PAPER TRANSPORT SECTION

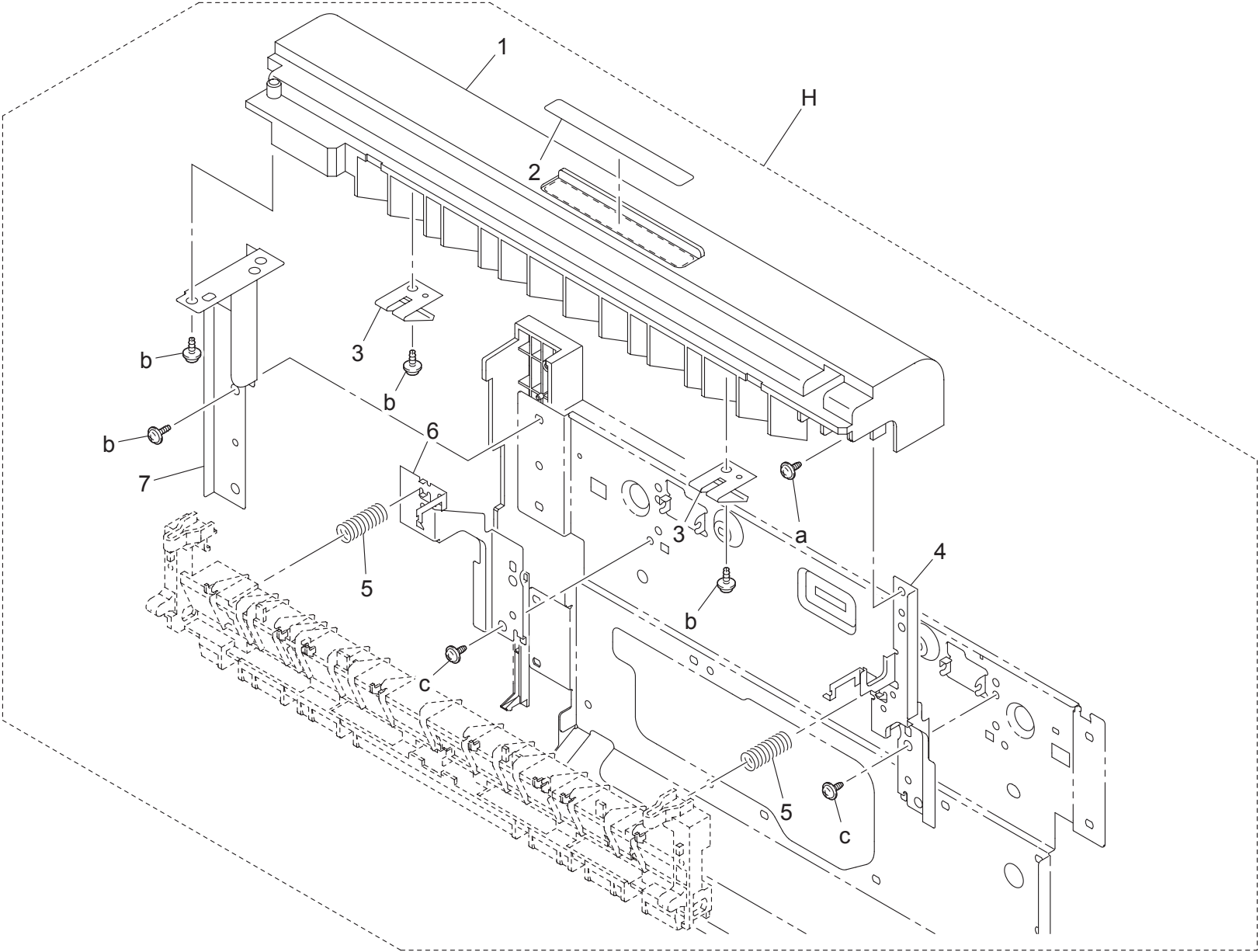



# ELECTRICAL COMPONENTS

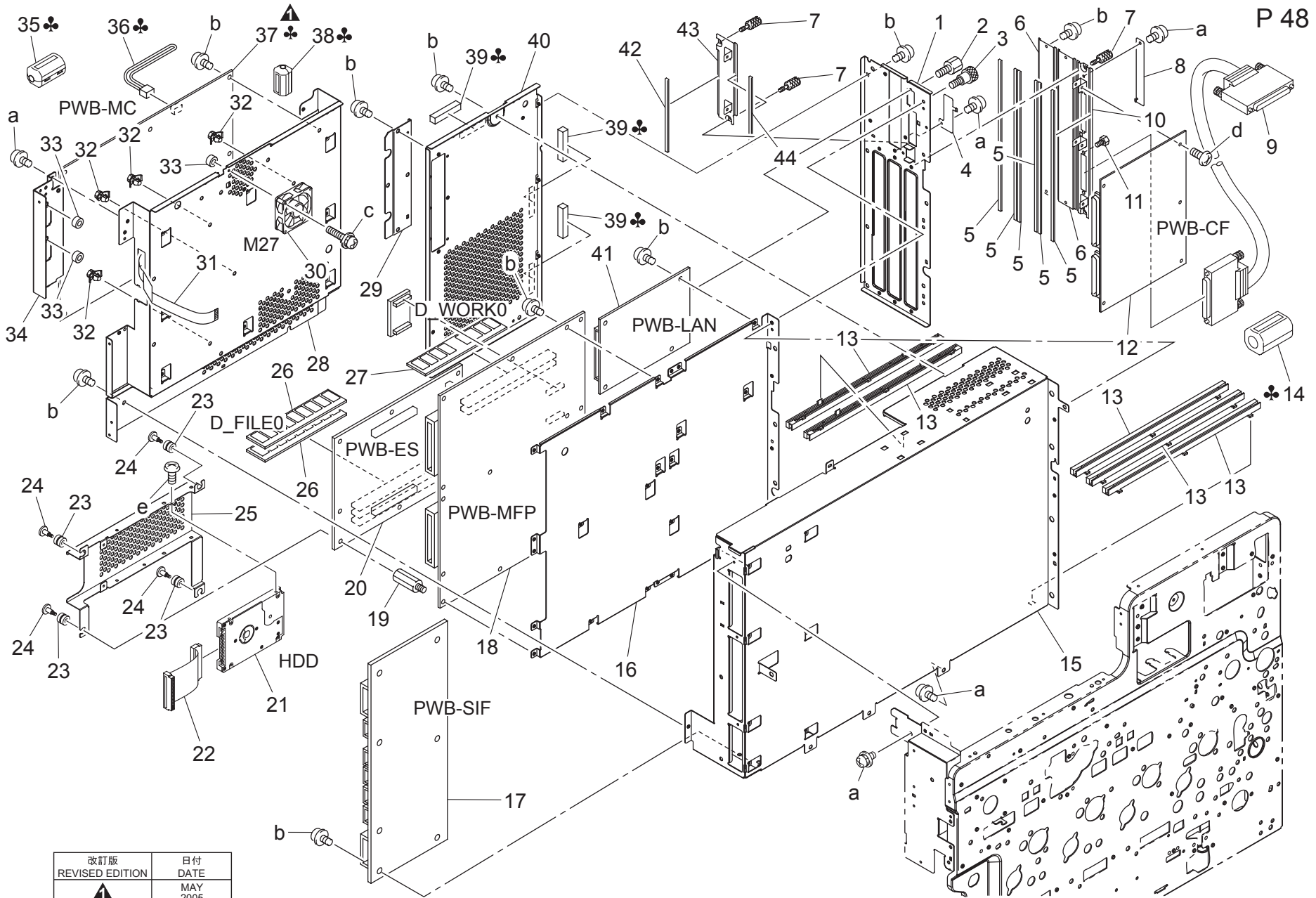

改訂版 REVISED EDITION	日付 DATE
▲	MAY 2005

ELECTRICAL COMPONENTS

Key	Part No.	Description	Destinations	Class	QTY	Standard parts
1	4037 2207 03	SHIELD BOX	シールドボックス	D	1	a-9646 0306 14 b-9646 0308 14 c-9646 0316 14 d-9654 0306 14 e-9654 0304 14
2	4025 2287 01	SCREW	ねじ	C	2	
3	4110 2311 01	SCREW	ねじ	C	4	
4	4037 2242 01	COVER	カバー	D	1	
5	4037 6776 01	ELECTRICALLY CONDUCTIVE MATERIAL	導電材料	D	6	
6	4037 2247 01	COVER	カバー	D	2	
7	4037 2220 02	SHOULDER SCREW	段ねじ	C	4	
8	4037 2240 01	COVER	カバー	D	1	
9	4036 6861 01	WIRE HARNESS ASSY	ハーネス ASSY	D	1	
10	4037 2217 02	BRACKET ASSY	取付板 ASSY	D	1	
11	4581 2269 02	SHOULDER SCREW	段ねじ	C	2	C,J,D,F2,G1,I,K,H
12	4037 0134 04	PWB-CF	PWB-CF	I	1	
13	4004 2203 01	GUIDE	ガイド	D	5	
14	9326 1000 61	FERRITE CORE	フェライトコア	D	1	
15	4037 2201 03	SHIELD BOX	シールドボックス	D	1	
16	4037 2260 02	BRACKET	取付板	D	1	
17	4037 0130 04	PWB-SIF	PWB-SIF	I	1	
18	4037 0131 04	PWB MFP	PWB-MFP	I	1	
19	4037 2283 01	SHOULDER SCREW	段ねじ	C	7	
20	4037 0132 04	PWB-ES	PWB-ES	C	1	
21	4037 6095 01	HARD DISK DRIVE	ハードディスクドライブ	I	1	
22	4036 6870 01	WIRE HARNESS ASSY	ハーネス ASSY	D	1	
23	4025 2294 01	BUSHING	ブッシュ	C	4	
24	4036 2487 01	SHOULDER SCREW	段ねじ	C	4	
25	4037 2234 01	BRACKET	取付板	D	1	
26	4037 6076 01	D_FILE0	FILE0	C	2	C,J,D,F2,G1,I,K,H
27	4037 6081 01	PWB-D_WORK0	PWB-D_WORK0	C	1	
28	4037 2206 02	BRACKET	取付板	D	1	
29	4037 2244 01	COVER	カバー	D	1	
30	9313 1400 31	FAN MOTOR	ファンモータ	C	1	
31	4037 6831 01	WIRE HARNESS ASSY	ハーネス ASSY	D	1	C,J,D,F2,G1,I,K,H
32	9384 1610 11	PWB SUPPORT	キバンサポート	D	4	
33	1154 4670 01	PROTECTION	保護材	C	3	
34	4037 2246 02	BRACKET	取付板	D	1	
35	9326 1810 21	FERRITE CORE	フェライトコア	D	1	
36	4036 6831 01	WIRE HARNESS ASSY	ハーネス ASSY	D	1	A,B,G2,H,F1 (bizhub C450) (bizhub C351)
37	4037 7803 01	PWB-MC	PWB-MC	I	1	
37	4037 7804 01	PWB-MC	PWB-MC	I	1	
38	9326 1200 61	FERRITE CORE	フェライトコア	D	1	
39	4037 6779 01	ELECTRICALLY CONDUCTIVE MATERIAL	導電材料	D	3	
40	4037 2202 03	SHIELD BOX	シールドボックス	D	1	C,J,D,F2,G1,I,K,H
41	4037 0133 04	PWB-LAN	PWB-LAN	C	1	
42	4037 6777 01	ELECTRICALLY CONDUCTIVE MATERIAL	導電材料	D	1	
43	4037 2219 02	BRACKET	取付板	D	1	
44	4037 6778 02	ELECTRICALLY CONDUCTIVE MATERIAL	導電材料	D	1	

MULTIPURPOSE CASSETTE

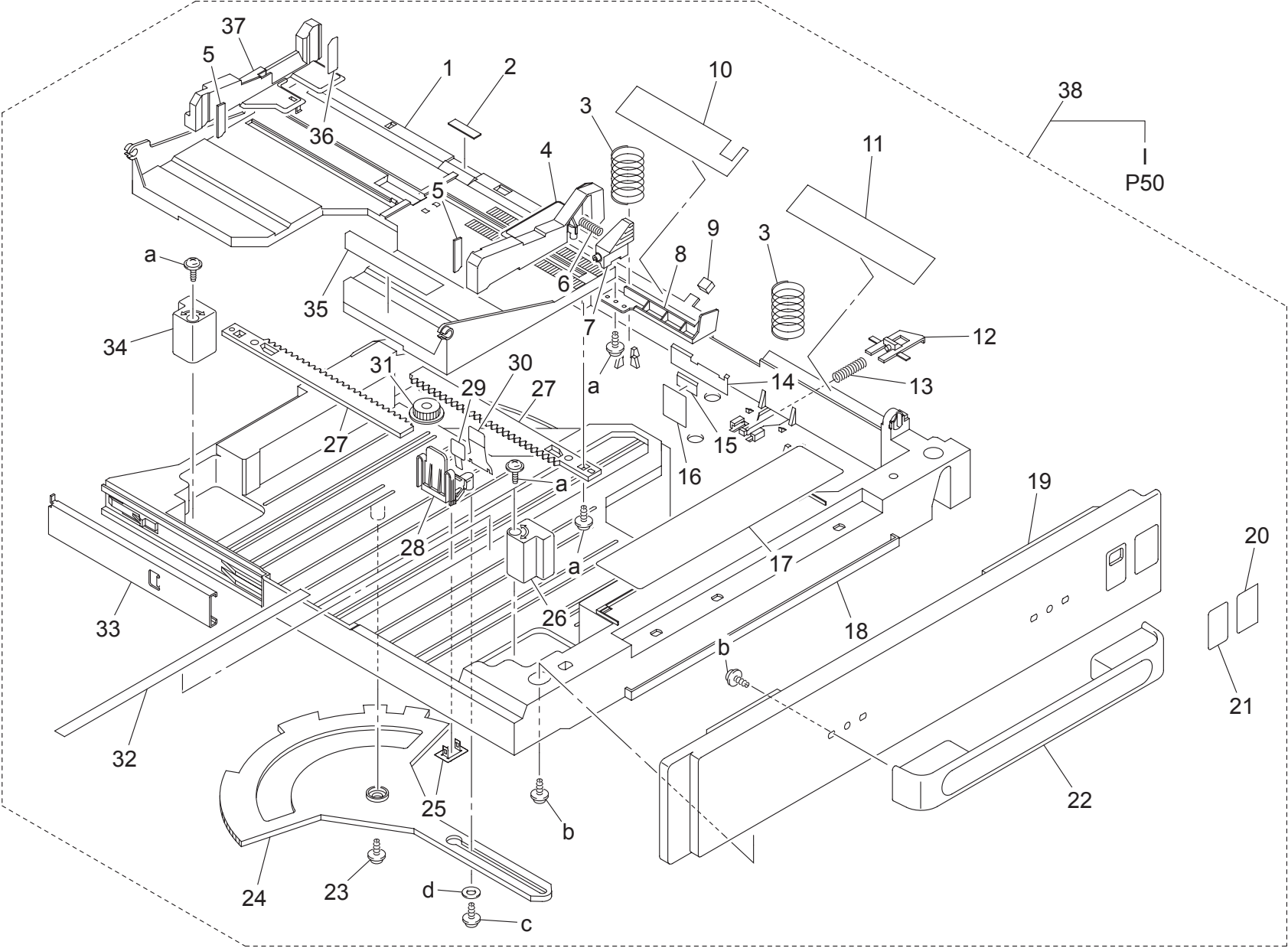

MULTIPURPOSE CASSETTE

Key	Part No.	Description	Destinations	Class	QTY	Standard parts
1	4036 3022 01	LIFTING PLATE		D	1	a-9739 0308 14 b-9739 0410 14 c-9739 0310 14 d-9716 0300 01
2	1164 3064 01	FRICITION SHEET		C	1	
3	4134 3106 01	PRESSURE SPRING		C	2	
4	4036 3008 01	REGULATING PLATE		D	1	
5	4036 3086 01	BRAKE		D	2	
6	4011 3011 01	PRESSURE SPRING		C	1	
7	4037 3210 01	LEVER		C	1	
8	4036 3019 01	LEVER		D	1	
9	1164 3009 01	CLANING MATERIAL		C	1	
10	4004 3040 02	GUIDE		C	1	
11	4004 3024 01	GUIDE		C	1	
12	1164 3061 01	LEVER		C	1	
13	1164 3062 01	PRESSURE SPRING		C	1	
14	4004 3033 01	GUIDE PLATE		D	1	
15	4004 3038 01	GUIDE		C	1	
16	4004 3008 01	SEAL		C	1	
17	4037 7306 12	LABEL		C	1	
18	4036 3021 02	CASSETTE		D	1	
19	4036 3020 02	MPC COVER		C	1	
20	4036 7307 01	LABEL CASSETTE CNT		D	1	
21	4030 7301 02	LABEL NEAR EMPTY		C	1	
22	4036 3025 01	HANDLE		C	1	
23	4163 5293 01	SCREW		C	1	
24	4004 3051 02	LEVER		C	1	
25	4004 3031 01	BRACKET		D	1	
26	4037 3226 01	SPACER		D	1	
27	4004 3032 01	RACK		C	2	
28	4004 3023 01 Old	REGULATING PLATE		D	1	
28	4037 3223 01	REGULATING PLATE		D	1	
29	4021 3036 01	GUIDE		C	1	
30	4004 3042 01	GUIDE		C	1	
31	1164 3045 01	GEAR 20T		C	1	
32	4036 7313 01	LABEL MP FD		D	1	
33	4004 3030 01	RAIL		D	1	
34	4037 3227 01	SPACER		D	1	
35	4036 7314 01	LABEL MP CD		D	1	
36	4004 7324 01	LABEL CAPACITY		D	1	
37	4036 3028 01	REGULATING PLATE		D	1	
38	4037 0756 00	MULPIPURPOSE CASSETTE		S	1	

MULTIPURPOSE CASSETTE

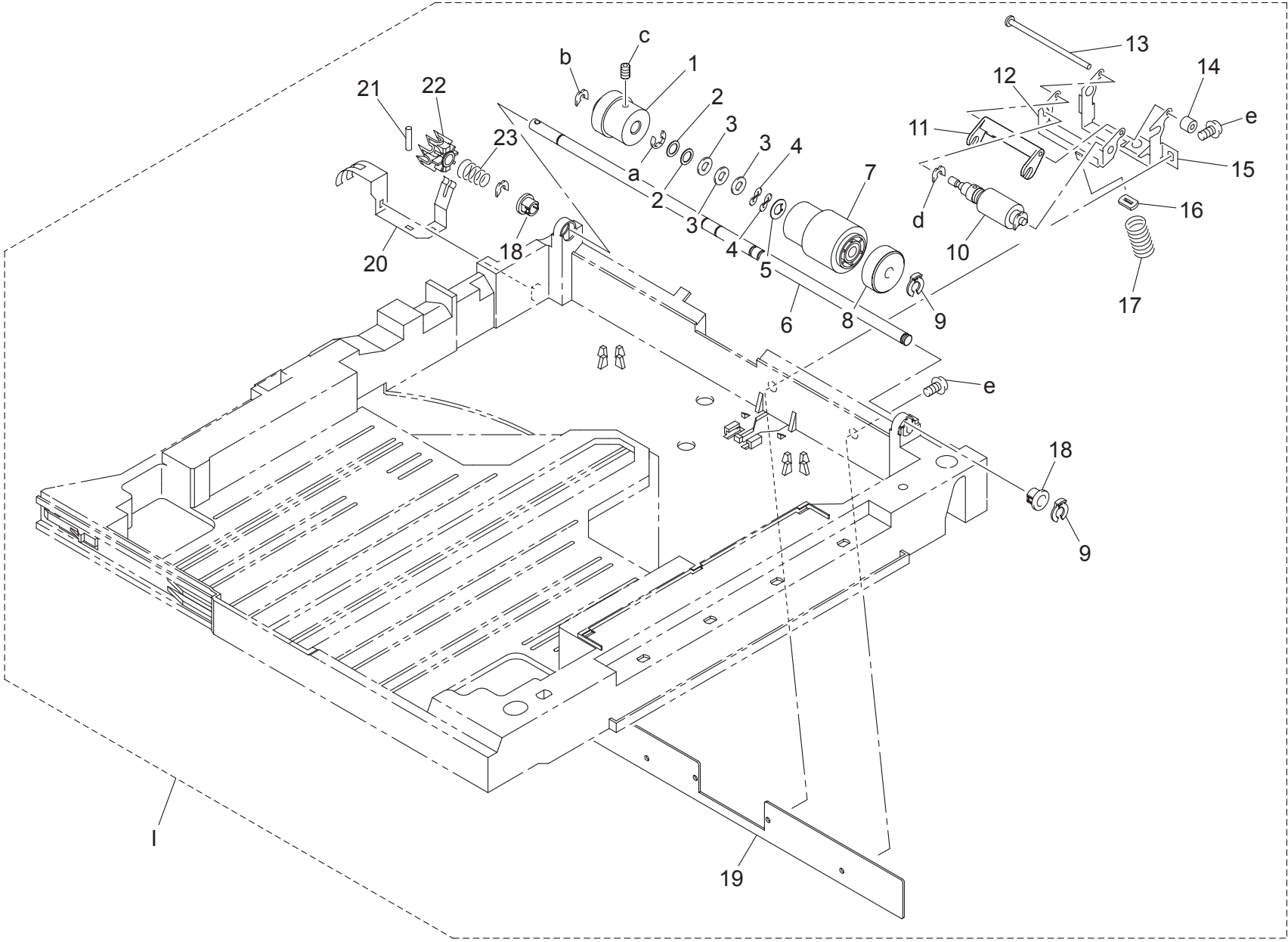



MULTIPURPOSE CASSETTE

Key	Part No.	Description	Destinations	Class	QTY	Standard parts
1	4036 3063 01	WEIGHT	重り	D	1	a-9721 0600 01 b-1066 1151 01 c-9684 0406 08 d-4425 3002 01 e-9654 0408 14
2	1200 1462 01	WASHER	ワッシャー	C	2	
3	1200 1462 03	WASHER	ワッシャー	C	3	
4	1500 2660 13	WAVE WASHER	ナミワッシャー	C	2	
5	1164 3066 01	WASHER	ワッシャ	C	1	
6	4004 3001 02	SHAFT	シャフト	D	1	
7	4021 3012 01	ROLLER	ローラ	A	1	
8	4004 3005 01	COLLAR	カラー	C	1	
9	1164 3065 01	STOPPER RING	トメリング	D	2	
10	4034 0151 01	SEPARATION ROLLER	分離ローラ	A	1	
11	4658 3035 02	GUIDE	ガイド	D	1	
12	4004 3003 02	HOLDER	ホルダ	D	1	
13	4658 3040 01	SHAFT	シャフト	D	1	
14	4658 3047 01	COLLAR	カラー	C	1	
15	4004 3004 01	BRACKET	取付板	D	1	
16	1144 3097 03	HOLDER	ホルダ	D	1	
17	4004 3006 03	PRESSURE SPRING	圧縮コイルばね	C	1	
18	1164 3003 01	BUSHING	軸受	C	2	
19	4036 3040 01	REINFORCE PLATE	補強板	D	1	
20	4036 3018 01	EARTH GROUND	アース	D	1	
21	4036 3014 01	PIN	ピン	D	1	
22	1164 3004 03	PAWL	爪	C	1	
23	1164 3005 02	PRESSURE SPRING	圧縮コイルばね	C	1	

UNIVERSAL CASSETTE

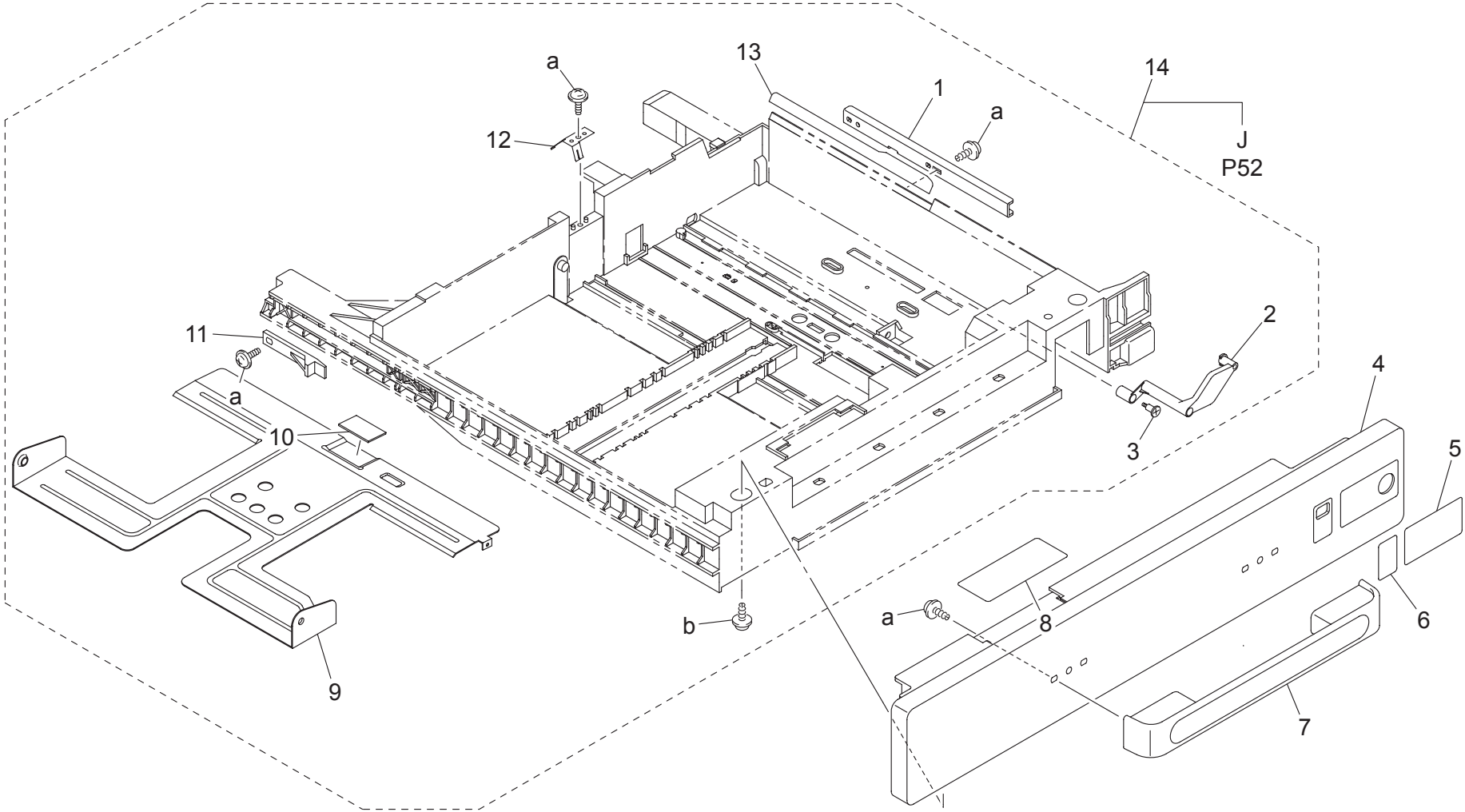

UNIVERSAL CASSETTE

Key	Part No.	Description	Destinations	Class	QTY	Standard parts
1	4030 3229 02	REINFORCE PLATE		D	1	a-9739 0308 14 b-9739 0410 14
2	4030 3221 01	LEVER		C	1	
3	4030 3224 01	SHOULDER SCREW		C	1	
4	4030 3202 02	FRONT COVER CASSETTE		C	1	
5	4030 7303 02	LABEL CASSETTE CNT 2		C	1	
6	4030 7301 02	LABEL NEAR EMPTY		C	1	
7	4036 3025 01	HANDLE		C	1	
8	4040 7304 01	LABEL PAPER SUPPLY		C	1	
9	4030 3203 01	LIFTING PLATE		D	1	
10	4030 3226 01	FRICTION SHEET		C	1	
11	4498 3469 01	STOPPER		D	1	
12	4030 3223 02	EARTH GROUND		C	1	
13	4030 3222 03	GUIDE		C	1	
14	4040 0156 01	CASSETTE ASSY		S	1	

UNIVERSAL CASSETTE

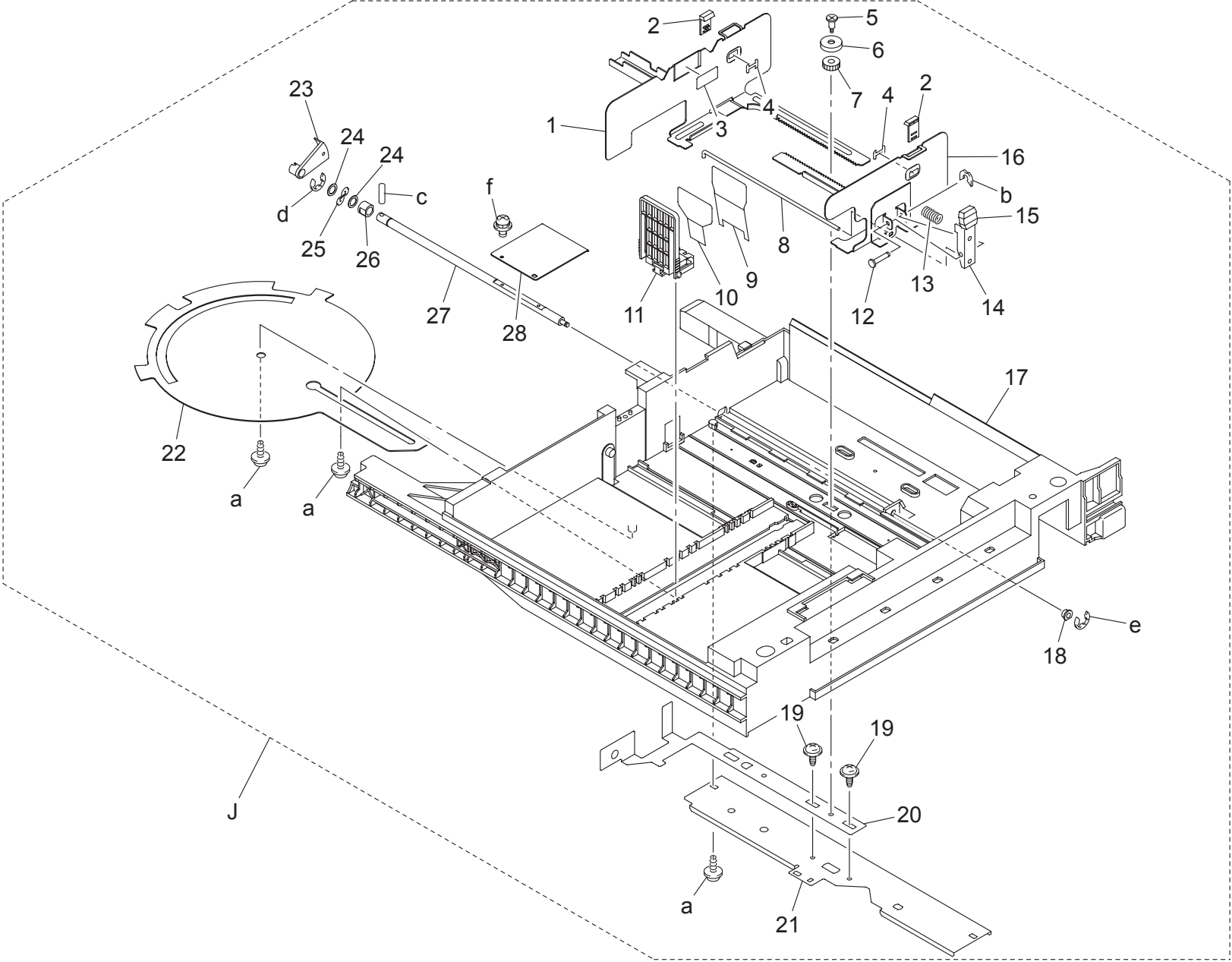

UNIVERSAL CASSETTE

Key	Part No.	Description	Destinations	Class	QTY	Standard parts
1	4030 3212 01	REGULATING PLATE		D	1	a-9739 0308 14 b-4425 3002 01 c-9754 3025 08 d-9721 0600 01 e-9721 0300 01 f-9646 0308 14
2	4658 3048 01	GUIDE		D	2	
3	4002 7306 01	LABEL CARRYING CAPACITY		D	1	
4	4658 3049 01	STOPPER		C	2	
5	4030 3214 01	SHOULDER SCREW		C	1	
6	4030 3215 01	GUIDE		D	1	
7	4658 3012 01	GEAR 14T		C	1	
8	4030 3217 01	SHAFT		D	1	
9	4030 3228 01	GUIDE		C	1	
10	4030 3227 01	GUIDE		C	1	
11	4037 3213 01	REGULATING PLATE		D	1	
12	4498 3826 01	SHAFT		D	1	
13	4498 3825 01	PRESSURE SPRING		C	1	
14	4128 3823 01	LEVER		D	1	
15	4037 3204 01	KNOB		D	1	
16	4030 3211 02	REGULATING PLATE		D	1	
17	4030 3201 03	CASSETTE		D	1	
18	0992 3014 01	BUSHING		C	1	
19	4498 3834 01	SCREW		C	2	
20	4030 3216 01	BRACKET		D	1	
21	4030 3218 01	BRACKET		D	1	
22	4002 3108 01	LEVER		C	1	
23	4030 3207 01	ACTUATOR		C	1	
24	1200 1462 01	WASHER		C	2	
25	1500 2660 13	WAVE WASHER		C	1	
26	1274 3603 01	BUSHING		C	1	
27	4030 3205 01	SHAFT		D	1	
28	4030 3206 01	LEVER		D	1	

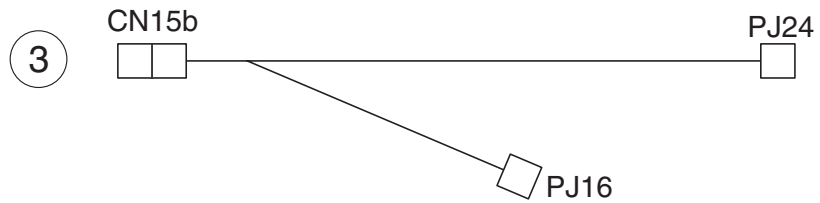
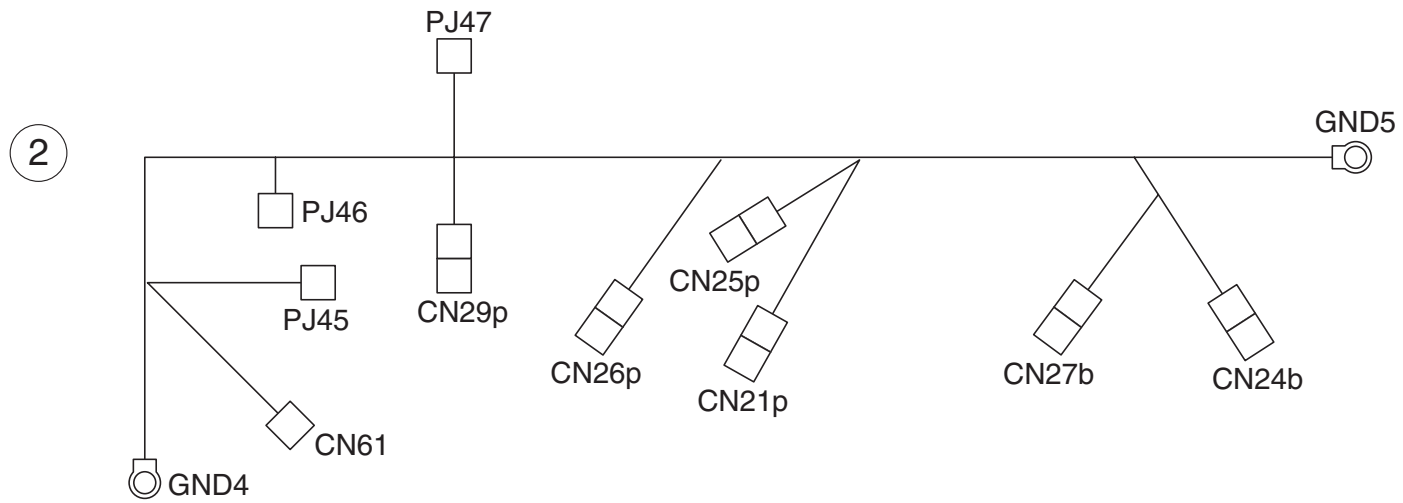



# WIRING

P 54

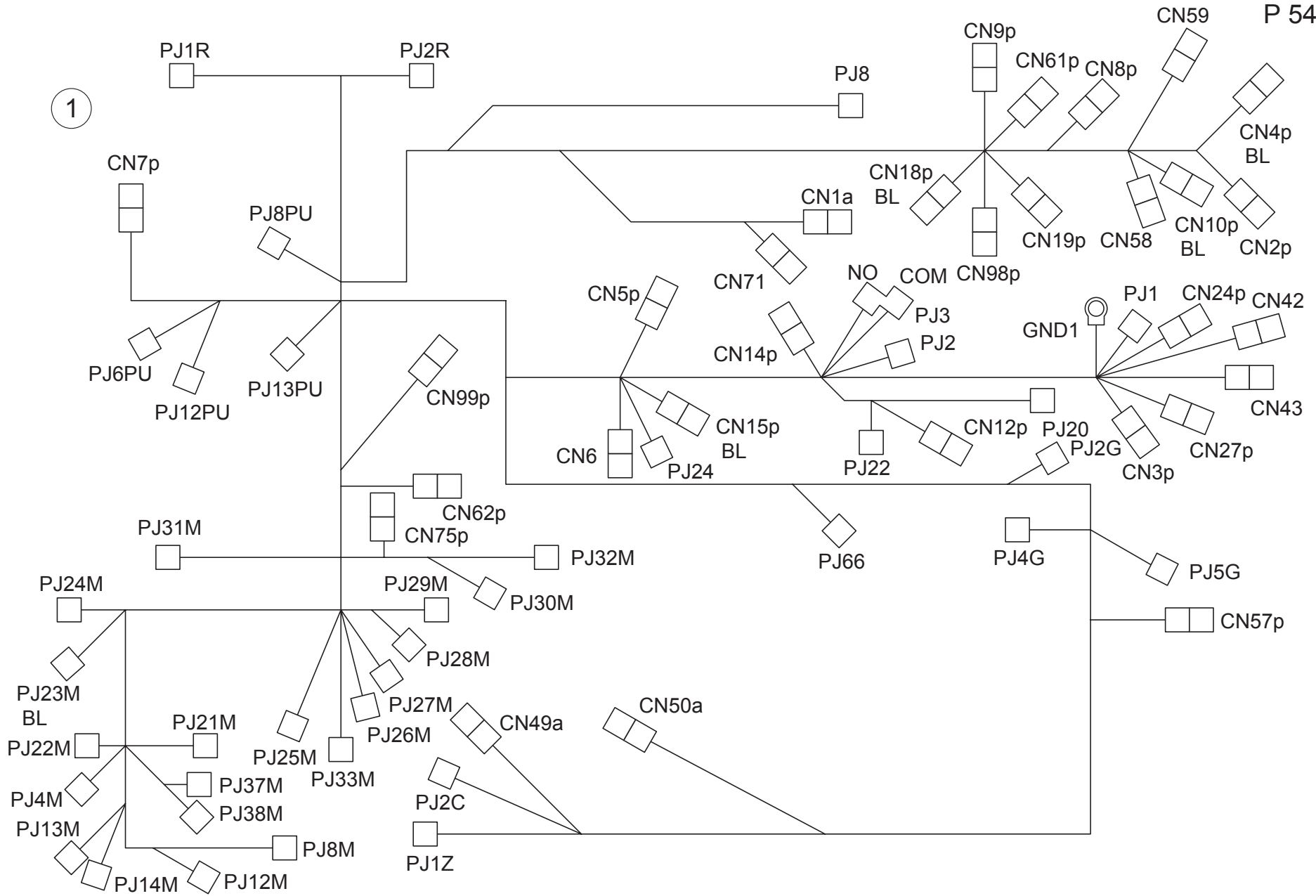



WIRING

Key	Part No.	Description	Destinations	Class	QTY	Standard parts
1	4037 6801 03	WIRE HARNESS ASSY	(bizhub C450)	D	1	
1	4037 6809 01	WIRE HARNESS ASSY	(bizhub C351)	D	1	

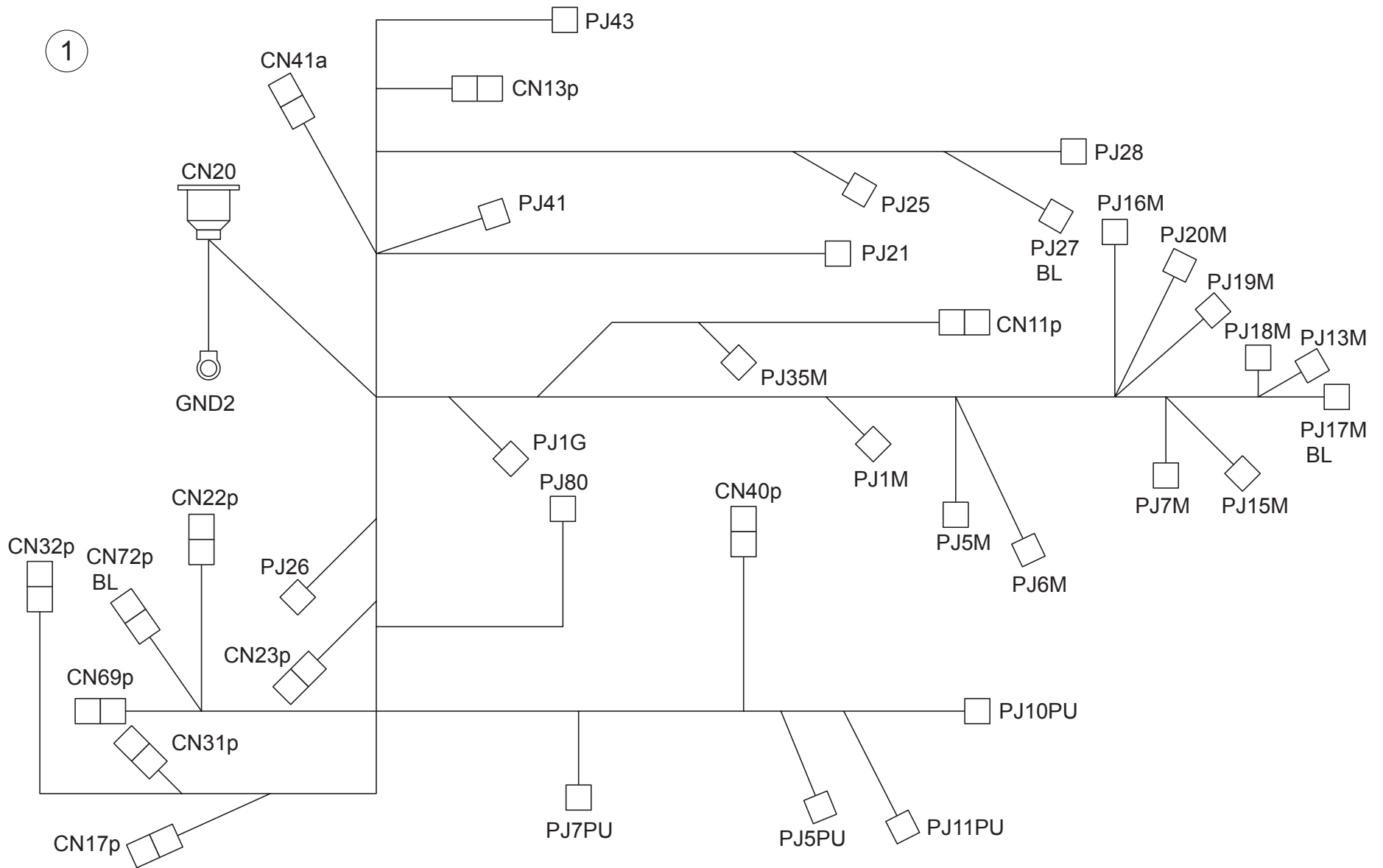



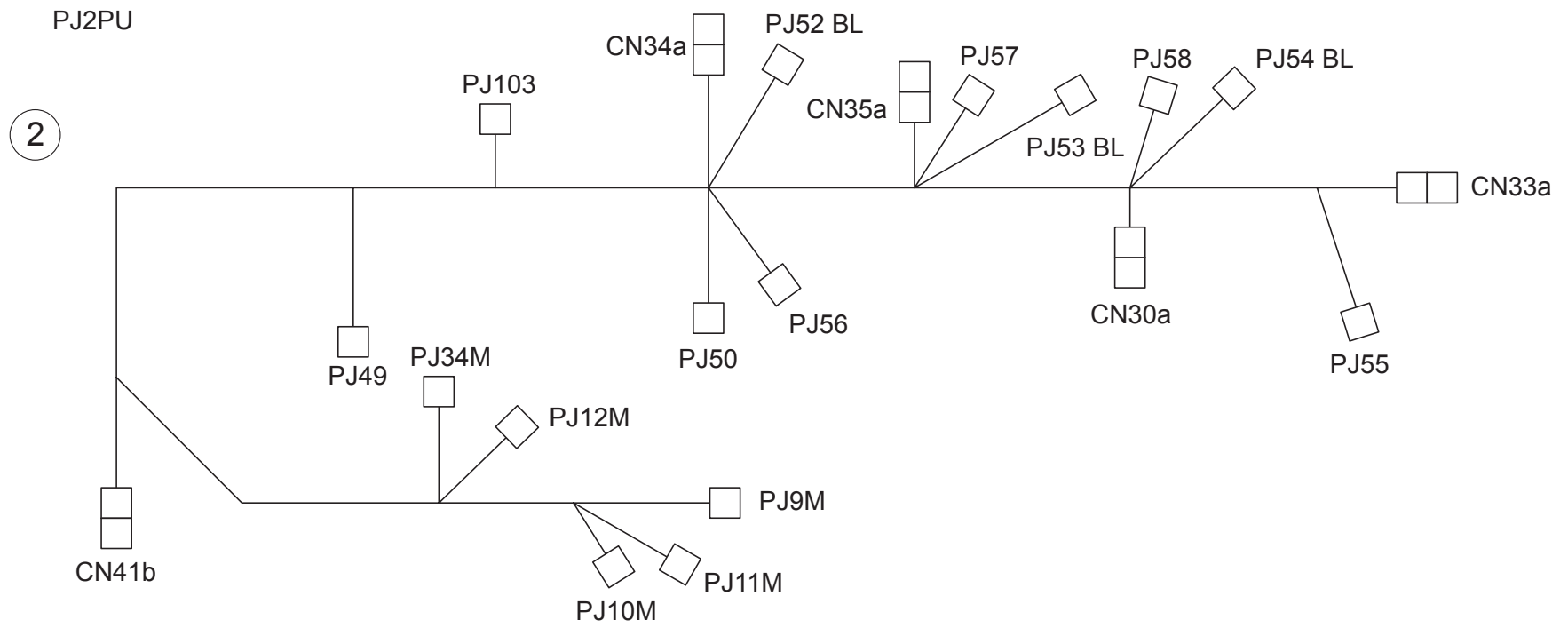
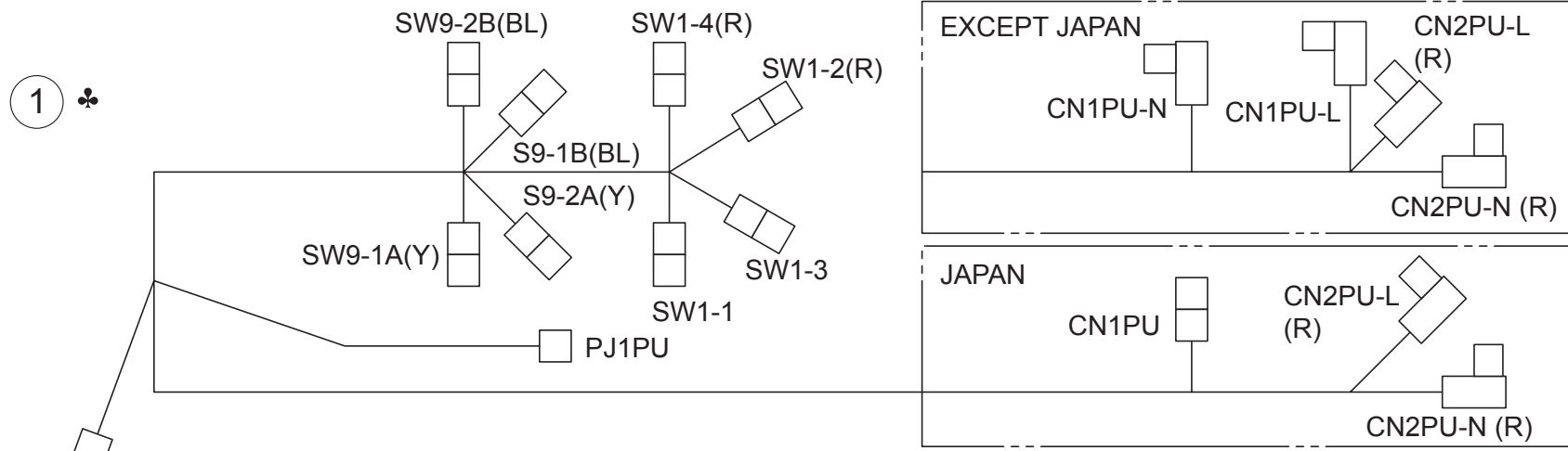



# WIRING

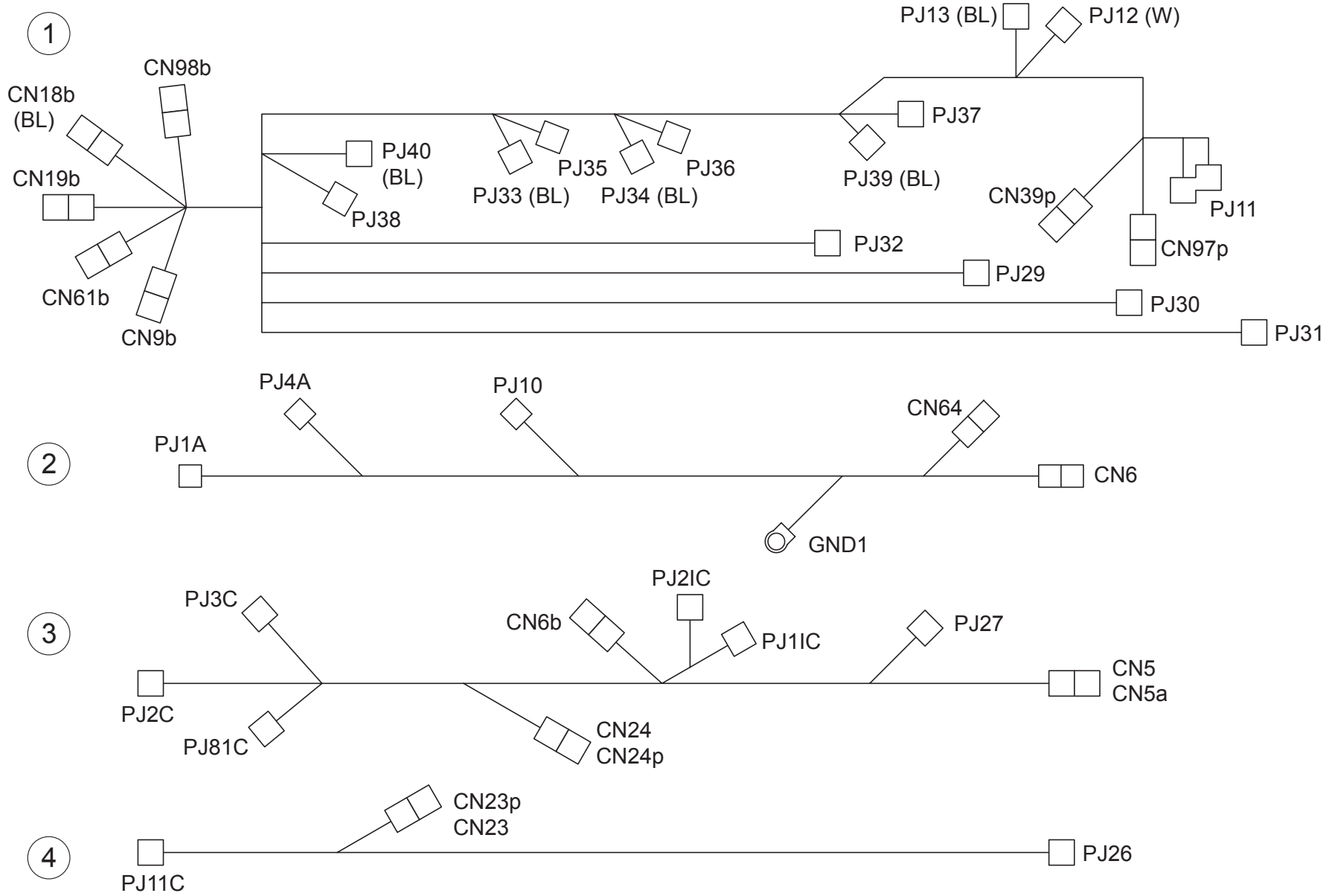



# WIRING ACCESSORIES AND JIGS

1 	6 	11♣ 	16 	21 	26 	31 	36
2 	7 	12 	17 	22 	27 	32 	37
3♣ 	8 	13 	18 	23 	28 	33 	38
4 	9 	14 	19 	24♣ 	29 	34	39
5 	10 	15 	20 	25 	30 	35	40



WIRING ACCESSORIES AND JIGS

Key	Part No.	Description	Destinations	Class	QTY	Standard parts
1	9384 1000 51	WIRING SADDLE		D	6	
2	9384 1100 91	WIRING SADDLE		D	66	
3	9384 1300 71	WIRING SADDLE		D	1	
4	9384 1921 01	WIRING SADDLE 14.4H	C,J,D,F2,G1,I,K	D	3	
5	9384 1921 21	WIRING SADDLE 15.2H		D	4	
6	9384 1211 01	WIRING SADDLE 19.2H		D	24	
7	9384 1110 61	WIRING SADDLE 21.5H		D	6	
8	9384 1311 01	WIRING SADDLE 27H		D	10	
9	9384 1310 11	WIRING SADDLE 5.2H		D	35	
10	9384 1310 81	WIRING SADDLE 6.4H		D	10	
11	9384 1820 31	WIRING SADDLE 8.0H	C,J,D,F2,G1,I,K	D	1	
12	9384 1921 11	WIRING SADDLE 9.2H		D	6	
13	9384 1100 21	WIRWG SADDLE 16H		D	3	
14	1053 4812 01	CORD CLAMP		D	2	
15	1065 5872 02	CORD CLAMP		D	8	
16	9384 1300 51	CORD CLAMP		D	1	
17	9384 1300 61	CORD CLAMP		D	3	
18	9384 1811 01	CORD CLAMP		D	1	
19	9384 2910 21	EDGE COVER		D	5	
20	9384 2910 31	EDGE COVER		D	11	
21	9384 2010 21	EDGE COVER 8.5H		D	34	
22	1050 4805 01	INSULATING MEMBER		D	2	
23	1052 4301 01	GROMMET		D	1	
24	9384 1521 51	CORD BUSHING		D	1	
25	9384 1311 11	CABLE TIE 104L	A	D	15	
26	9384 1100 31	RETAINER		D	1	
27	4004 7502 01	CLANING MATERIAL		S	1	
28	4004 7503 12	CLEANING PAD		S	1	
29	4037 0751 01	COMPACT FLASH	(bizhub C450)	S	1	
29	4037 0751 01	COMPACT FLASH	(bizhub C351)	S	1	
30	1174 7901 01	JIG		S	1	
31	4025 7901 01	JIG		S	2	
32	4581 7901 02	JIG		S	2	
33	4581 1316 01	SEAL		C	7	

# ACCESSORY PARTS

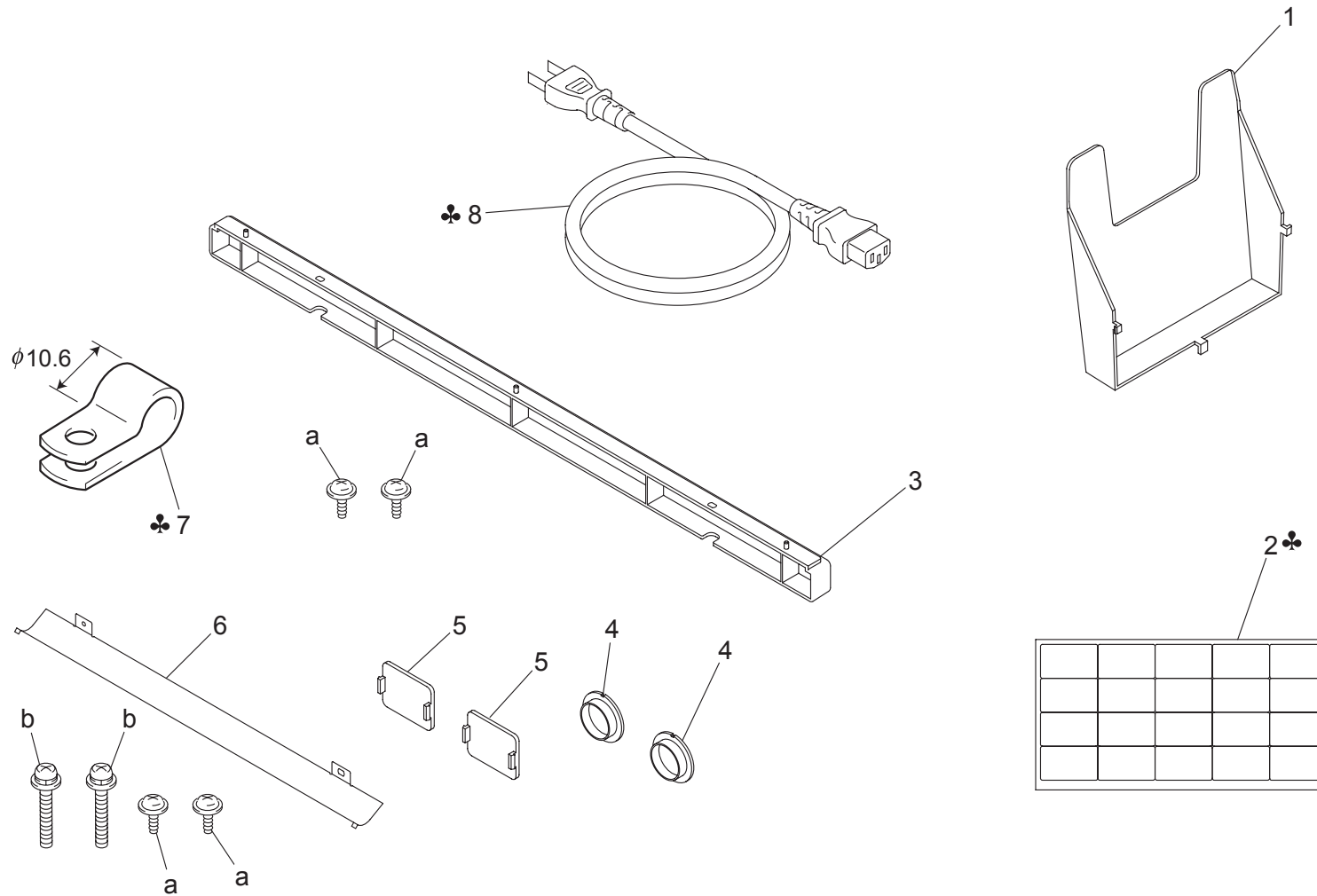



# MAINTENANCE LIST

● The items with no Page/Key numbers are not handled as spare parts.

No.	Section	PM Parts Description	Maintenance Cycle (K=1,000)		Parts No.	Destinations	Page/Key	Note
			QTY	Replace				
1	Tray 1	Paper Take-up Roller	1	200K	4021301201		P50-7	
2		Separation Roller Assy	1	200K	4034015101		P50-10	
3	Bypass	Paper Take-up Roller	1	200K	4131300101		P25-12	
4		Separation Roller Assy	1	200K	4034015101		P24-27	
5	Tray 2	Pick-up Roller	1	300K	4030300501		P26-11	
6		Paper Take-up Roller	1	300K	4030300501		P26-11	
7		Separation Roller Assy	1	300K	4030015101		P28-10	
8	Transport section	Paper Dust Remover	1	150K	1483076200		P44-20	
9		2nd Image Transfer Roller Unit	1	150K	4049411		P45-22	
10	Fusing section	Fusing Unit	1	300K	4049521	A	P31-27	
10	Fusing section	Fusing Unit	1	300K	4049522	C J D F2 G1 I K	P31-27	
10	Fusing section	Fusing Unit	1	300K	4049523	B G2 F1 G2 B	P31-27	
10	Fusing section	Fusing Unit	1	300K	4049524	H	P31-27	
11	EP section	Imaging Unit C/M/Y	1	50K	1483075700		P1-22	Dust filter *2 P.15-11
12		Imaging Unit K	1	100K				
13		Ozone Filter	1	150K				
14		Toner Cartridge (YMCK)	1	11.5K				
15	Image transfer section	Image Transfer Belt Unit	1	300K	4049212		P36-22	
16		Waste Toner Box	1	30K	4049111		P34-27	
17	ADF section	Pick-up Roller	2	200K	4582302201		P4-3(DF-601)	
18		Paper Take-up Roller	1	200K	4582301401		P4-7(DF-601)	
19		Separation Roller	1	200K	4582304701		P3-3(DF-601)	

\*1: Actual durable cycle is the Life counter value.

\*2: Also replace the Deodorant filter/2 packed in the black imaging unit at the same time when 100K is reached.

\*3: Also replace the Deodorant filter/1 packed in the black toner cartridge at the same time when 11.5K is reached.

# メンテナンスリスト

● ページ / キーナンバーのないものは、アフターサービス部品ではありません。

No.	区分	PM 部品名称	サイクル (K=1,000)		部品番号	仕向地	頁 / キー	備考
			員数	交換				
1	トレイ1	給紙ローラ	1	200K	4021301201		P50-7	
2		分離ローラ Ass y	1	200K	4034015101		P50-10	
3	手差し	給紙ローラ	1	200K	4131300101		P25-12	
4		分離ローラ Ass y	1	200K	4034015101		P24-27	
5	トレイ2	ピックアップローラ	1	300K	4030300501		P26-11	
6		給紙ローラ	1	300K	4030300501		P26-11	
7		分離ローラ Ass y	1	300K	4030015101		P28-10	
8	搬送部	紙紛除去クリーナ	1	150K	1483076200		P44-20	
9		2次転写ローラユニット	1	150K	4049411		P45-22	
10	定着部	定着ユニット	1	300K	4049521	A	P31-27	
10	定着部	定着ユニット	1	300K	4049522	C J D F2 G1 I K	P31-27	
10	定着部	定着ユニット	1	300K	4049523	B G2 F1 G2 B	P31-27	
10	定着部	定着ユニット	1	300K	4049524	H	P31-27	
11	E P 部	イメージングユニット (YMC)	1	50K				
12		イメージングユニット (K)	1	100K				防塵フィルタ *2 P.15-11
13		オゾンフィルタ	1	150K	1483075700		P1-22	
14		トナーカートリッジ (YMCK)	1	11.5K				消臭フィルタ *3 P.15-4
15	転写部	転写ベルトユニット	1	300K	4049212		P36-22	
16		廃棄トナーボックス	1	30K	4049111		P34-27	
17	A D F 部	ピックアップローラ	2	200K	4582302201		P4-3(DF-601)	
18		給紙ローラ	1	200K	4582301401		P4-7(DF-601)	
19		分離ローラ	1	200K	4582304701		P3-3(DF-601)	

\*1: 実質交換サイクルの数値は、ライフカウンタの値である。

\*2: 防塵フィルタは、黒のイメージングユニットに同梱され、100K で同時交換する。

\*3: 消臭フィルタは、黒のトナーカートリッジに同梱され、11.5K で同時交換する。

## DESTINATION

Destination No.		Destinations		V	Hz	Model No.
A	A1	JAPAN		100	50/60	4037-011 4037-021
	A2	JAPAN		200	50/60	
B		USA, CANADA		120	60	4037-311 4037-316 4037-321
C		EUROPEAN TYPE		220-240	50/60	4037-211 4037-221
D	D1	S.E ASIA TYPE	THAILAND, SRI LANKA, SINGAPORE, MALAYSIA, HONG KONG, PAKISTAN, INDIA, BANGLADESH, INDONESIA	220-240	50/60	4037-215 4037-225
	D3	OCEANIA TYPE	AUSTRALIA, NEW ZEALAND	220-240	50/60	4037-215 4037-225
E		PHILIPPINES		220-240	50/60	
F	F1	SAUDI ARABIA		127	60	4037-314
	F2	SAUDI ARABIA		220-240	50/60	4037-215 4037-225
G	G1	C.S AMERICA		220-240	50/60	4037-215 4037-225
	G2	C.S AMERICA		120	60	4037-311 4037-314 4037-321
H		TAIWAN		110	60	4037-312
I		JORDAN, LEBANON, SYRIA, SOUTH AFRICA, IRAQ, IRAN, N.YEMEN, CAMEROON, UAE, BAHRAIN, OMAN, QATAR, KUWAIT, KENYA, TUNISIA, IVORY COAST, MOROCCO		220-240	50/60	4037-215 4037-225

<b>Destination No.</b>	<b>Destinations</b>	<b>V</b>	<b>Hz</b>	<b>Model No.</b>
J	CHINA	220-240	50/60	4037-212
K	KOREA	220-240	50/60	4037-215 4037-225