

# OEL Recommended Spare Parts List

B410



Revision 7

# B410d/B410dn

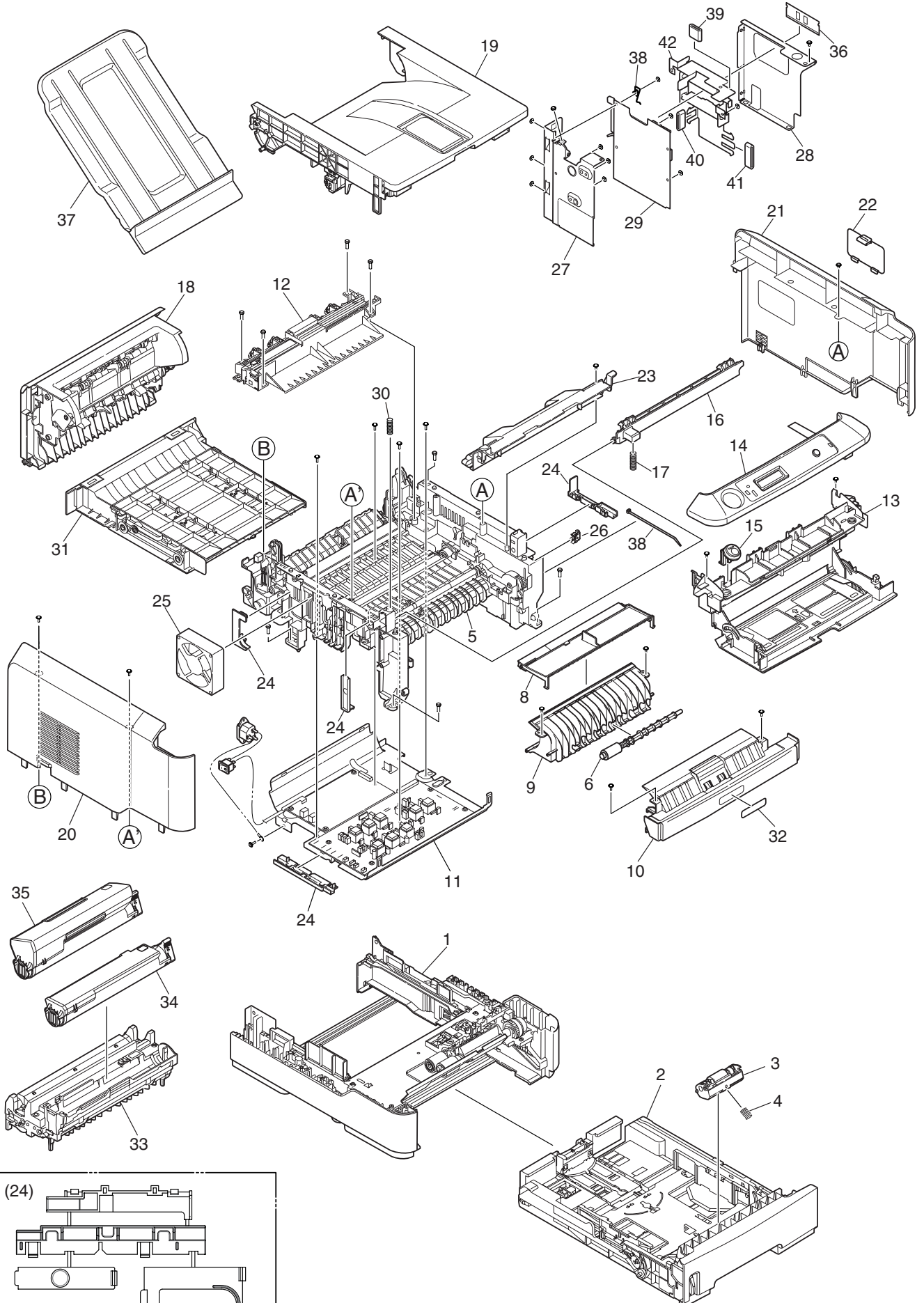

© OKI Systems (UK) Ltd.

For further information contact TCL Technology Ltd on +44 (0)1865 368232 or [spares@tcltech.co.uk](mailto:spares@tcltech.co.uk)

# Base-Assy

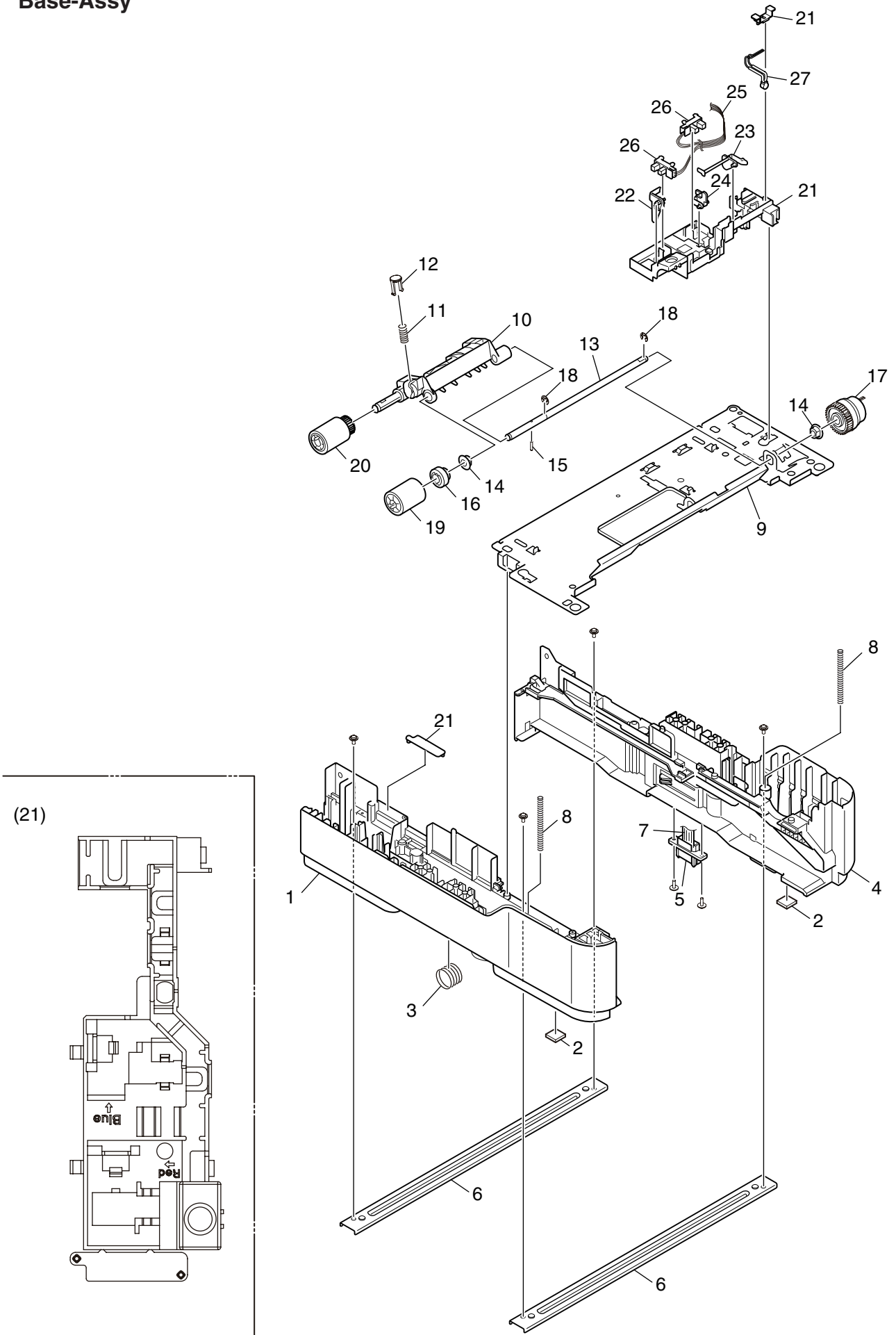

# Frame-Lower-Assy

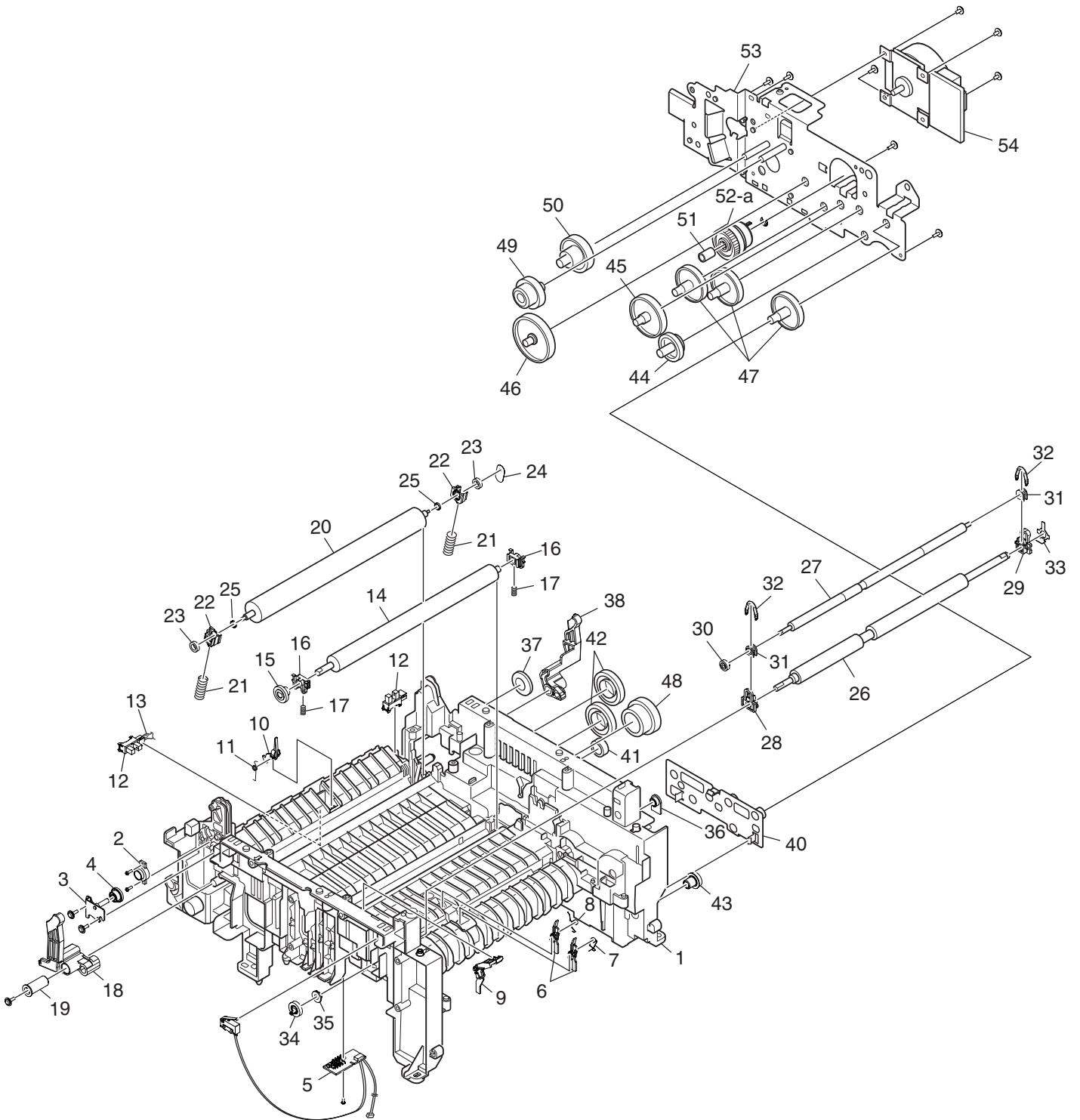

**PCB-Assy**

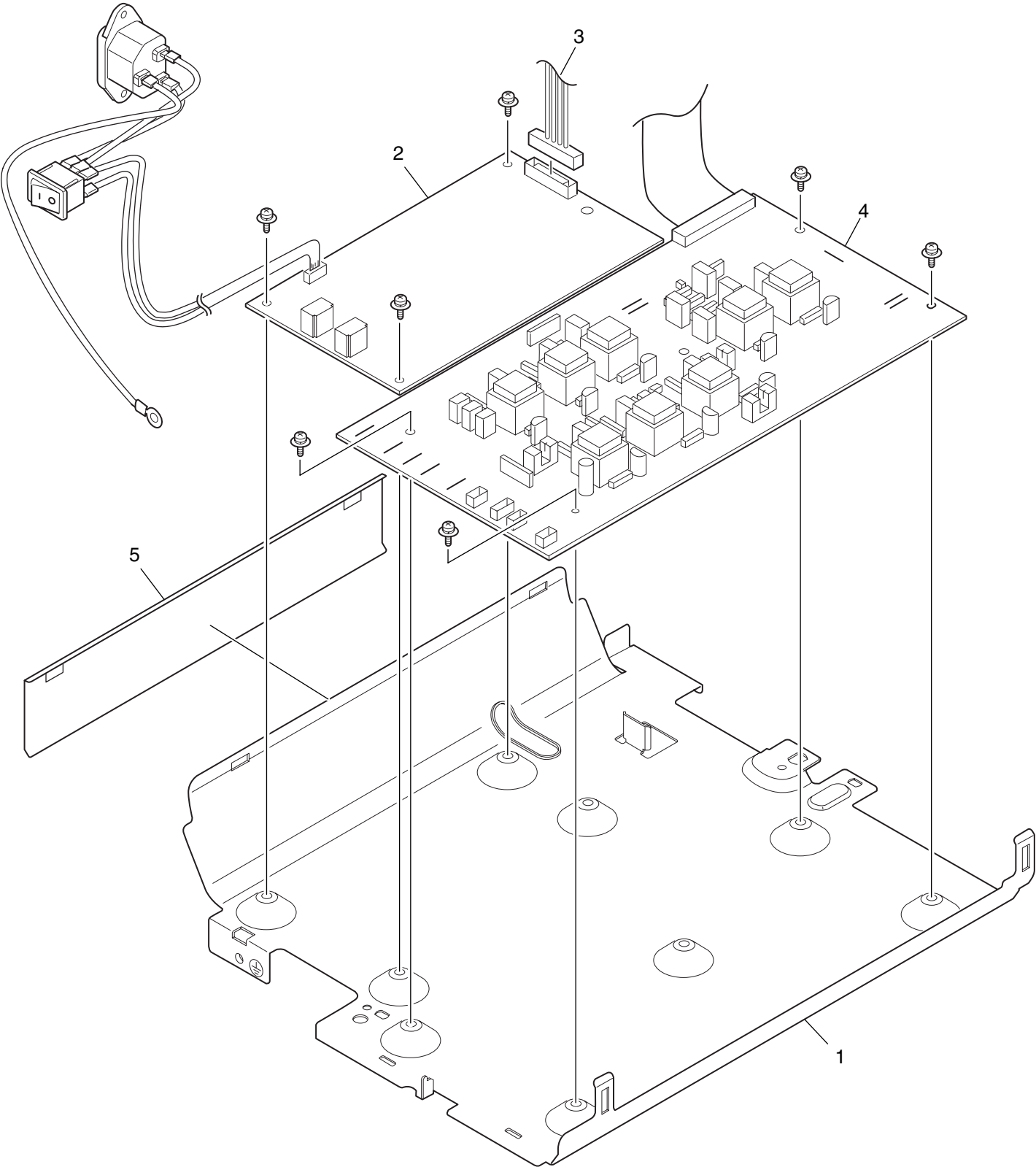

# Front-Guide-Assy

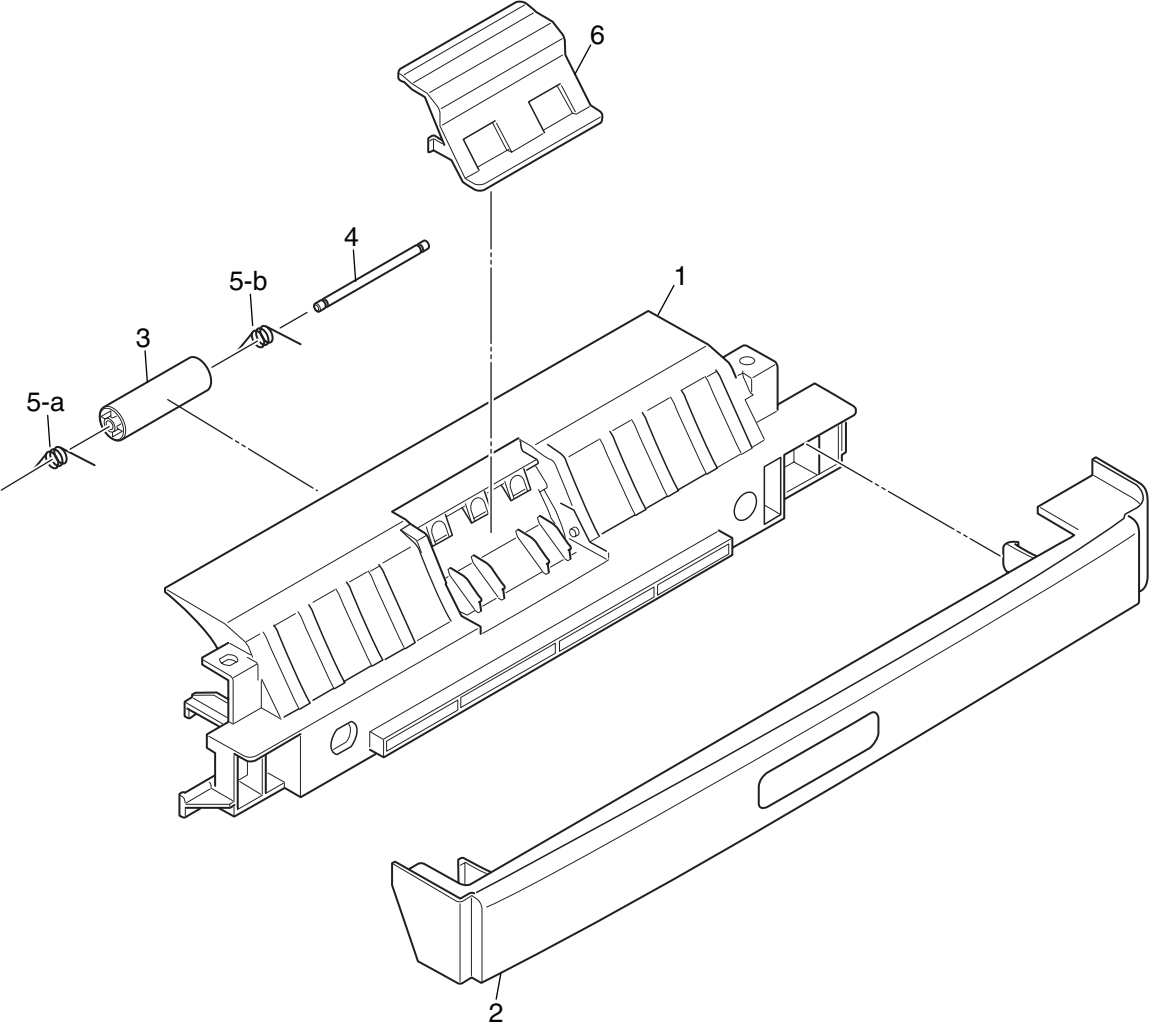

**Maunal-Assy**

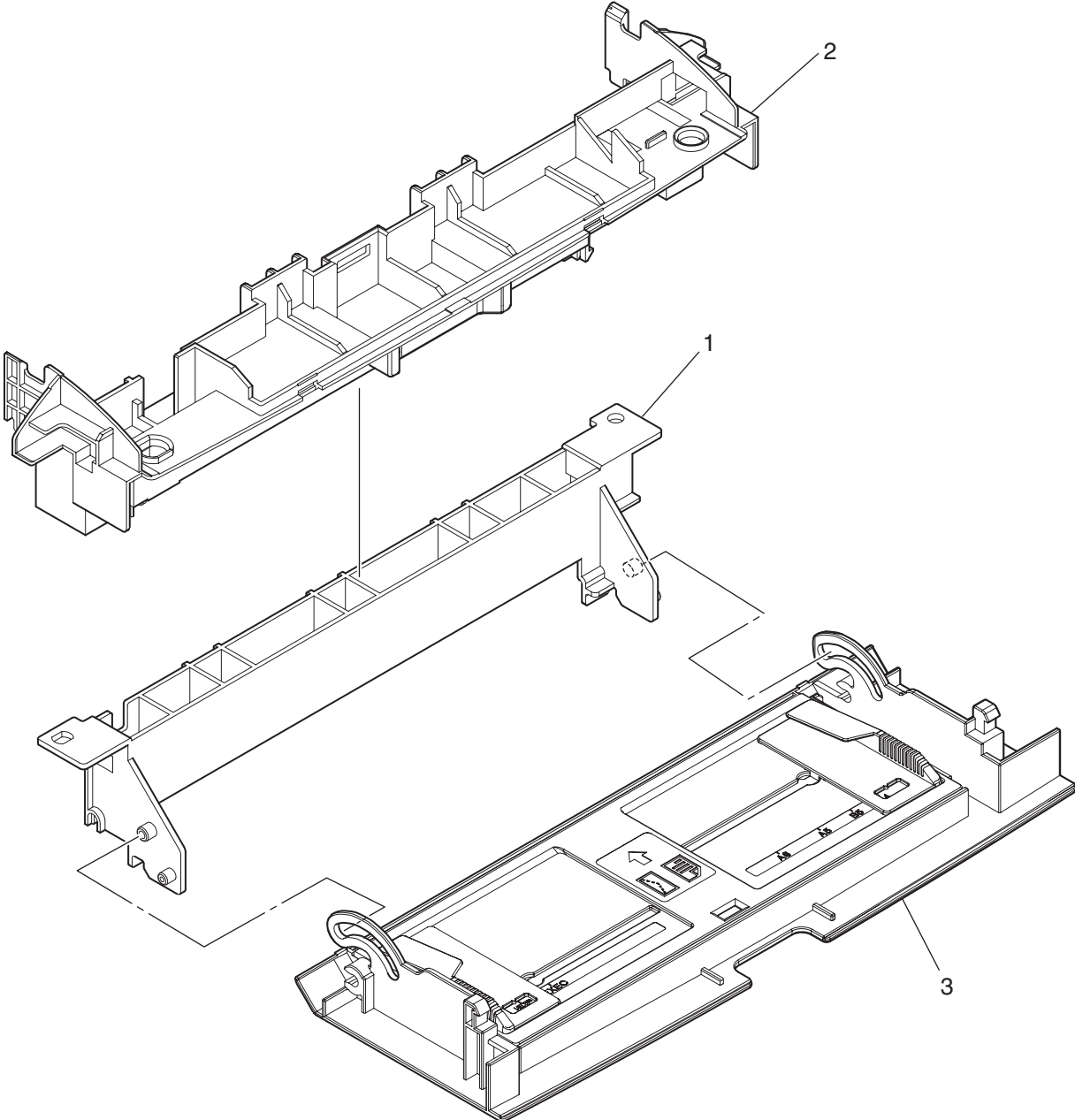

OPE-Cover-Assy

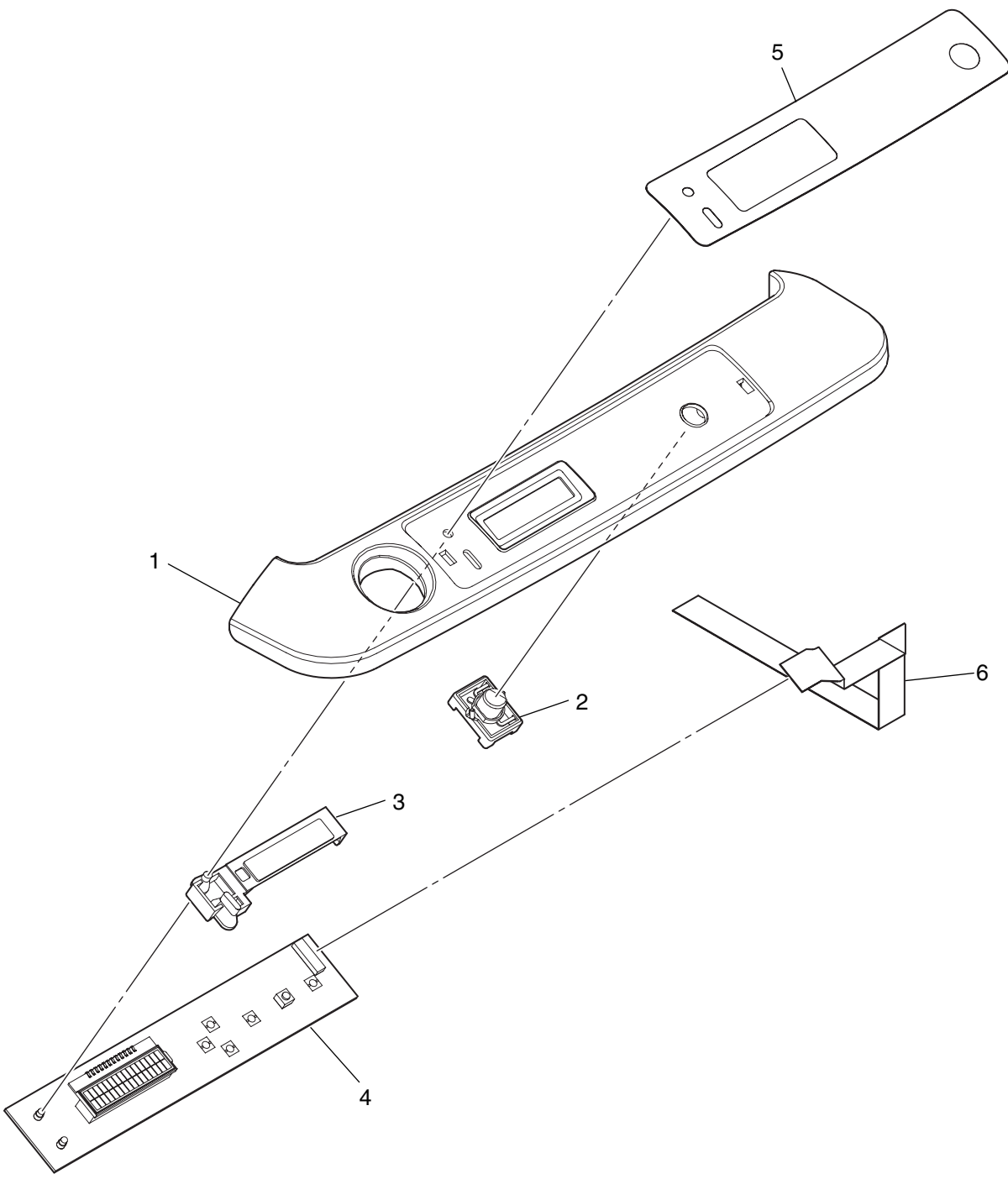



# Rear-Cover-Assy

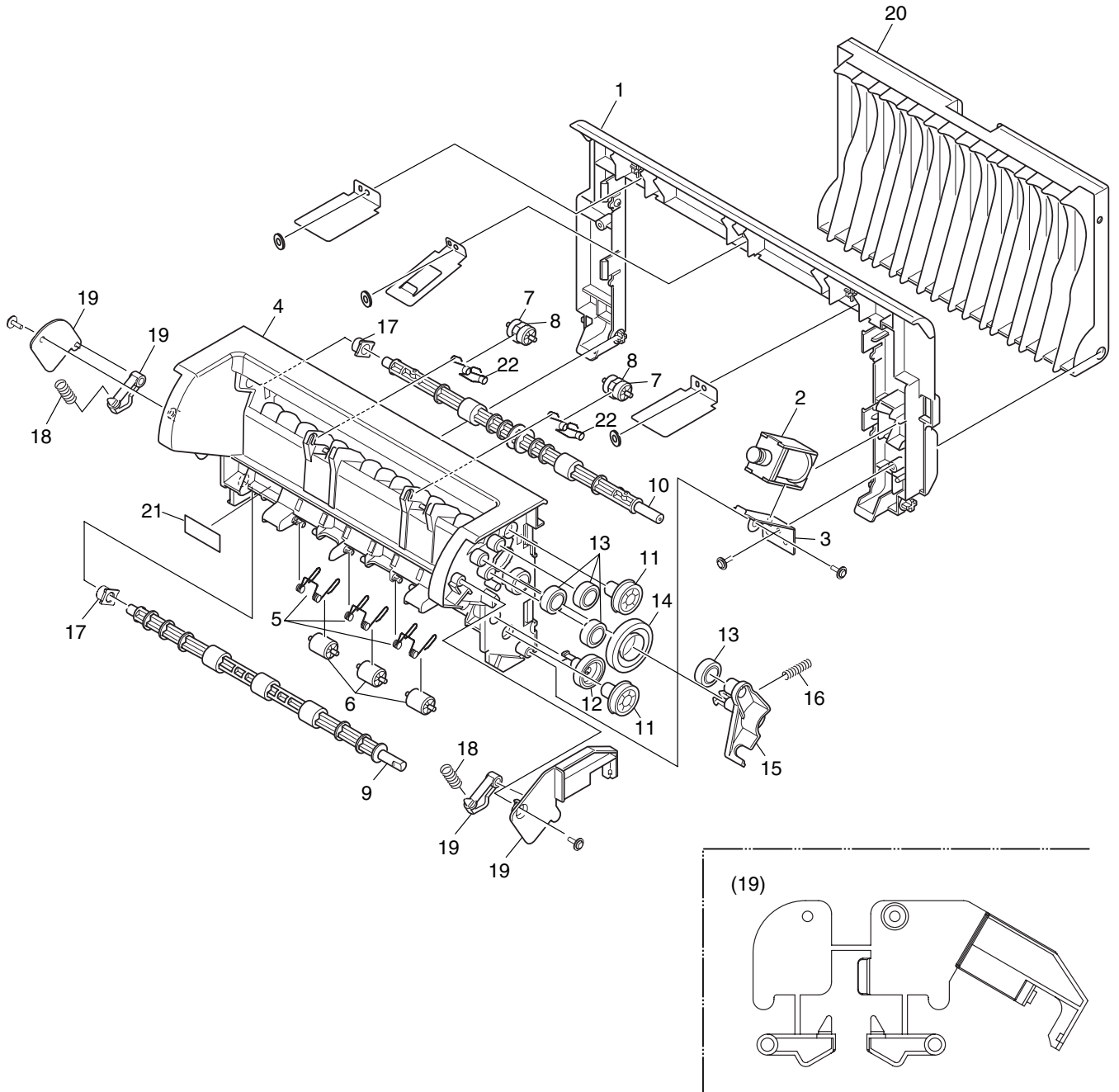

# Stacker-Cover-Assy

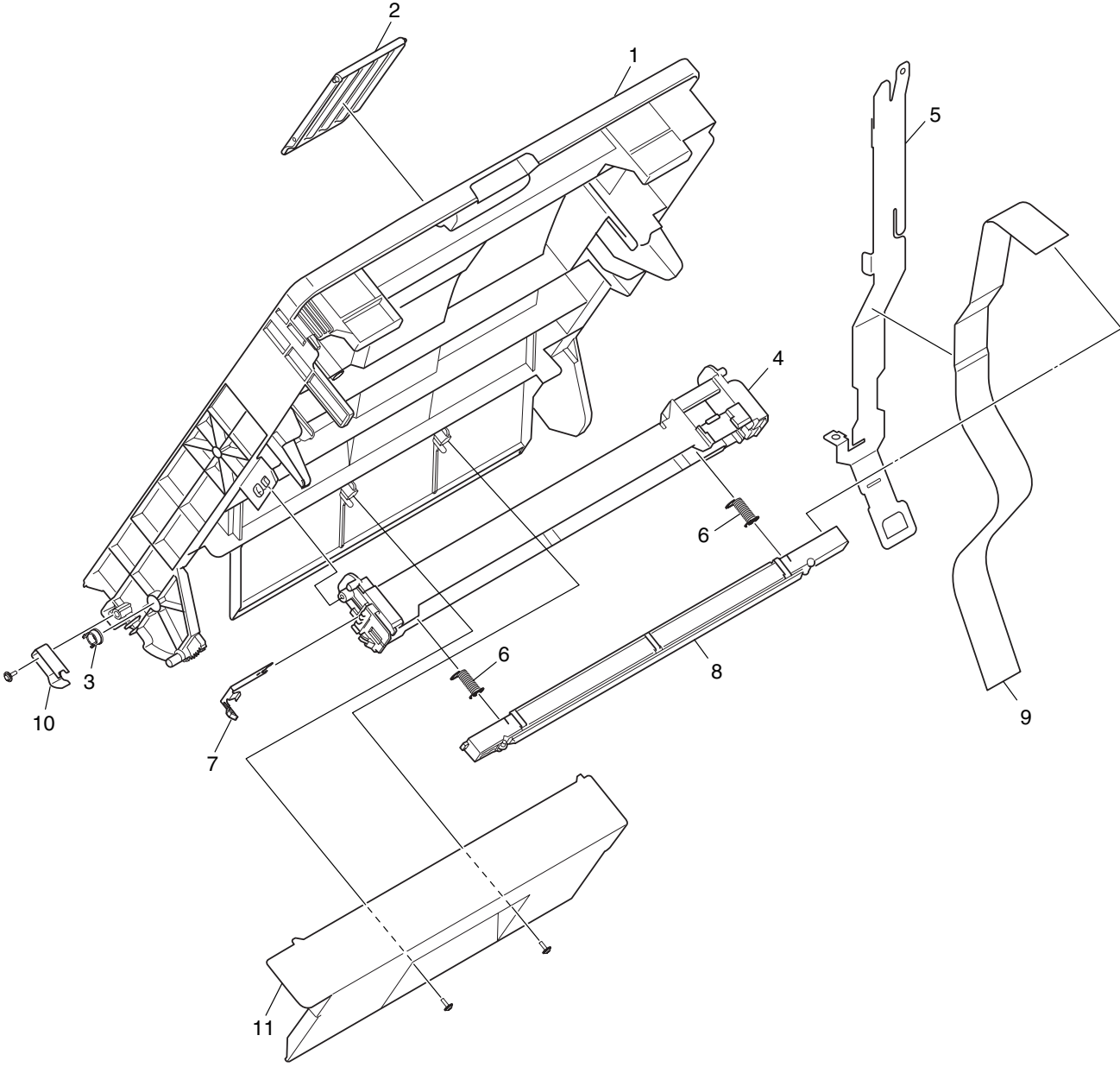

Rev	Unit Name	No.	Part No.	Part Name	Q'ty /Unit	Recommended Q'ty/Year			Remarks	Special (New Parts: *)	Del/ Add	Remarks for environment
						per 500	per 1000	per 2000				
	B410d/B410dn	2-a	43993301	Cassette- Assy.(250sht)	1	1	2	4		*		
	B410d/B410dn	3	43895001	Frame-Assy-Retard	1	1	2	4				
	B410d/B410dn	4	43963101	Spring-Retard	1	1	2	4				
2	B410d/B410dn	5	43993502	Frame-Assy.- Lower(Manual)	1	1	2	4		*		
2	B410d/B410dn	6	44071801	Roller Assy.-Feed	1	1	2	4		*		
	B410d/B410dn	12-b	43993902	Fuser-Assy.(230V)	1	5	10	20	230V	*		
	B410d/B410dn	13-a	43994201	Front-Assy.-Manual	1	1	2	4		*		
	B410d/B410dn	14-b	44019802	Cover Assy.- OPE(PN286-EURO)	1	1	2	4	OEL/AOS	*		
	B410d/B410dn	18-a	43994701	Cover-Assy.-Rear	1	1	2	4		*		
	B410d/B410dn	19-a	43994802	Cover-Assy.- Stacker(600dpi)	1	1	2	4		*		
6	B410d/B410dn	29-b	43963617	Board-87M-3(MN)	1	1	2	4	B410dn,CU board(NIC,OEL) F/W Version CU:A1.28,NIC:01.07/ W1.03	*		
6	B410d/B410dn	29-e	43963620	Board-87M-4(MN)	1	1	2	4	B410d,CU board(None NIC,OEL) F/W Version CU:A1.28	*		
	B410d/B410dn	31-a	43994901	Duplex-Assy.	1	1	2	4		*		
6	B410d/B410dn	38	LP-6401-B1	TYING CORD	1	1	2	4				
	Base-Assy	5	2233013P008	9715B-08Z02-G4C	1	1	2	4		*		
	Base-Assy	7	43961301	CONN Cord-AMP8P- AMP8P	1	1	2	4		*		
2	Base-Assy	17	43905401	Gear-Assy-Clutch	1	1	2	4		*		
	Base-Assy	19	43000601	Roller-Feed-NOW	1	1	2	4				
	Base-Assy	20	42699401	Roller-Pick-Up	1	1	2	4				
	Base-Assy	25	43961501	CONN Cord-AMP7- AMP3PX2	1	1	2	4		*		
	Base-Assy	26	40135301	Photo-Interrupter	2	2	4	8				
	Frame-Lower-Assy	5	43998001	Board-TT1	1	1	2	4		*		
	Frame-Lower-Assy	6	43903301	Lever-In-Sensor	2	2	4	8		*		
	Frame-Lower-Assy	7	42797101	Spring-Sensor_IN	1	1	2	4				
	Frame-Lower-Assy	8	41415801	Spring-WriteSensor	1	1	2	4				
	Frame-Lower-Assy	9	43993601	Sensor- Toner(Adhesive)	1	1	2	4		*		
	Frame-Lower-Assy	10	43206401	Lever-Eject-Sensor	1	1	2	4				
	Frame-Lower-Assy	11	40386501	Spring-SNS(F/R)	1	1	2	4				
	Frame-Lower-Assy	13	43961401	CONN Cord-AMP6P- AMP3PX2	1	1	2	4		*		
	Frame-Lower-Assy	14	43979601	Roller-Transfer(282)	1	1	2	4		*		
	Frame-Lower-Assy	16	43330101	Bearing-TR	2	2	4	8				
6	Frame-Lower-Assy	18	43903601	Lever-Reset-L	1	1	2	4		*		
	Frame-Lower-Assy	20	44009501	OR-Roller-Back up	1	1	2	4				
	Frame-Lower-Assy	22	43448601	Holder-BU	2	2	4	8				
	Frame-Lower-Assy	23	41584201	Bearing-Ball	2	2	4	8				
	Frame-Lower-Assy	24	PP4120- 1210P001	WASHER C	1	1	2	4				
4	Frame-Lower-Assy	25	43448702	Collar	2	2	4	8		*		
	Frame-Lower-Assy	26	43903701	Roller-Registration	1	1	2	4		*		
	Frame-Lower-Assy	31	41279401	Bearing-Pressure	2	2	4	8				
	Frame-Lower-Assy	35	41279301	Bearing-Regist L	1	1	2	4				
2	Frame-Lower-Assy	36	PP4083- 6031P001	BEARING R	1	1	2	4				
6	Frame-Lower-Assy	38	43904001	Lever-Reset-R	1	1	2	4		*		
	Frame-Lower-Assy	52-a	43905402	Gear-Assy-Clutch	1	1	2	4	Cable color; Blue	*		
	Frame-Lower-Assy	54	43906601	Motor-DC-Main	1	1	2	4		*		
7	PCB-Assy	2-b	44339001	PWR unit-ACDC Switch(230V)	1	1	2	4	Low voltage power supply board(230V)	*	A	
	PCB-Assy	3	43957601	JST8P-JST8P CONN Cord-Wire	1	1	2	4		*		
	PCB-Assy	4	43963701	PCB Assy. -87H	1	1	2	4	High voltage power supply board	*		
4	PCB-Assy	5	44121001	Film-Guide-Dup	1	1	2	4		*		
6	Front-Guide-Assy	3	43355101	Roller-Pinch	1	1	2	4		*		
	Rear-Cover-Assy	2	43988401	Solenoid	1	1	2	4		*		
	Rear-Cover-Assy	9	43995301	Roller-Assy.-	1	1	2	4		*		
	Rear-Cover-Assy	10	43995401	Roller-Assy.-	1	1	2	4		*		
	Stacker-Cover-	8	43406901	LED Head Unit-	1	1	2	4		*		