

Parts catalog

Legend

The following column headings are used in the parts catalog:

- **Asm-index**—Identifies the item in the illustration.
- **Part number**—Identifies the unique number that correlates with the part.
- **Units/mach**—Refers to the number of units actually used in the base machine or product.
- **Units/FRU**—Refers to the number of units in a particular FRU.
- **Description**—A brief description of the part.

The following abbreviations are used in the parts catalog:

- **NS** (not shown) in the Asm-index column indicates that the part is procurable but is not pictured in the illustration.
- **PP** (parts packet) in the Description column indicates that the part is contained in a parts packet.

Assembly 1: Covers

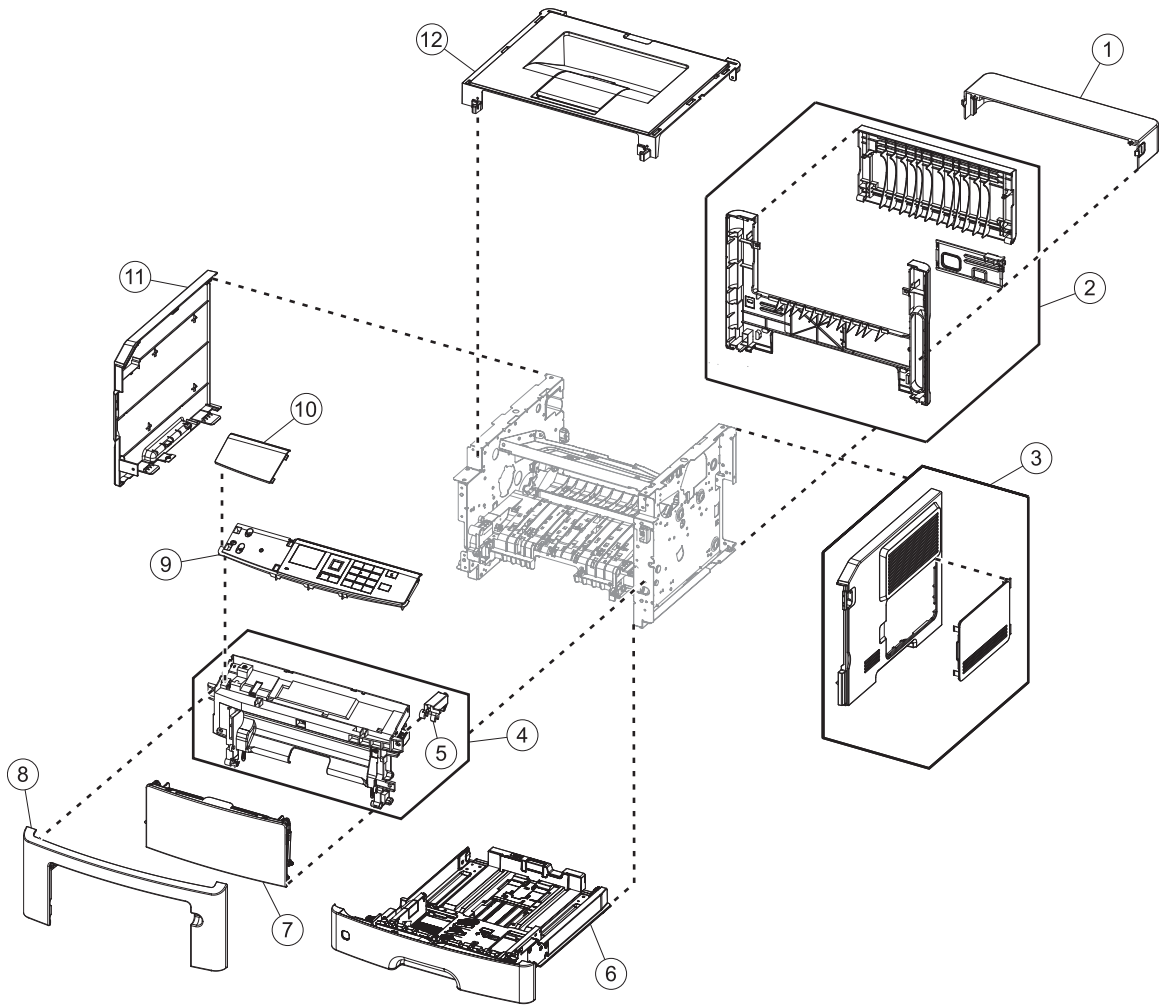

Assembly 1: Covers

Asm-index	P/N	Units/mach	Units/FRU	Description	Removal procedure
1	40X8520	1	1	Dust cover (250-sheet tray)	“Dust cover removal” on page 232
2	40X8054	1	1	Rear door and cover	“Rear door and cover removal” on page 232
3	40X8052	1	1	Right cover	“Right cover removal” on page 185
4	40X8056	1	1	Front access cover	“Front access cover removal” on page 211
5	40X9148	1	1	Cartridge plunger	“Cartridge plunger removal” on page 195
6	40X8303	1	1	250-sheet tray	N/A
7	40X8302	1	1	MPF assembly	“MPF assembly removal” on page 203
8	40X8051	1	1	Nameplate	“Nameplate removal” on page 199
9	40X8059	1	1	Control panel assembly Note: Does not include the UICC.	“Control panel assembly removal” on page 199 “UICC removal” on page 202
10	40X9659	1	1	Bezel (MS315)	“Bezel removal” on page 198
10	40X9660	1	1	Bezel (MS415 and M1140+)	“Bezel removal” on page 198
11	40X8053	1	1	Left cover	“Left cover removal” on page 168
12	40X8055	1	1	Top cover	“Top cover removal” on page 239
NS	40X8273	4	40	Rubber foot	N/A

Assembly 2: Electronics 1

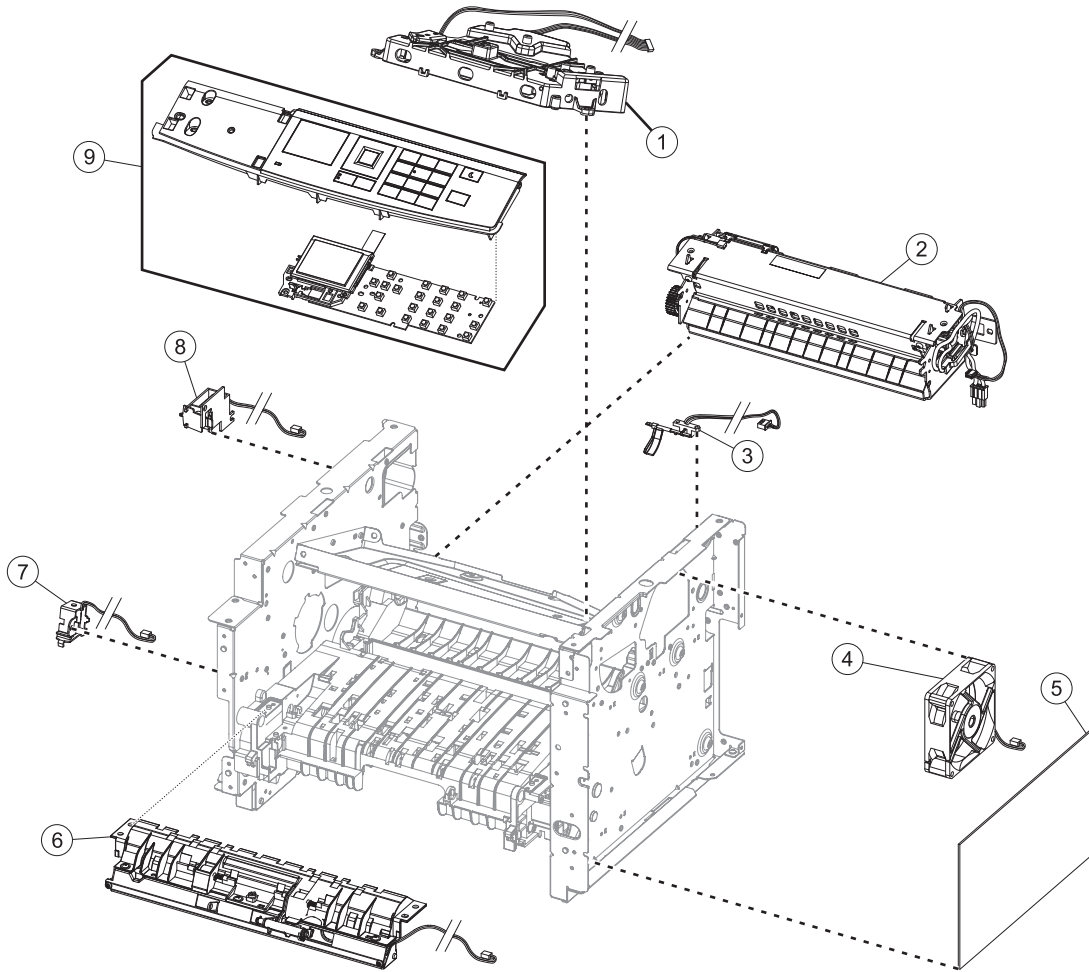

Assembly 2: Electronics 1

Asm-index	P/N	Units/mach	Units/FRU	Description	Removal procedure
1	40X8081	1	1	Laser scanning unit	“Laser scanning unit (LSU) removal” on page 240
2	40X8343	1	1	Fuser, 100 V	“Fuser removal” on page 238
2	40X8023	1	1	Fuser, 110 V	“Fuser removal” on page 238
2	40X8024	1	1	Fuser, 220 V	“Fuser removal” on page 238
3	40X8050	1	1	Narrow media/bin full sensor	“Narrow media/bin full sensor removal” on page 233
4	40X8276	1	1	Cooling fan	“Cooling fan removal” on page 186
5	40X9657	1	1	Controller board	“Controller board removal” on page 187
6	40X8280	1	1	Front input guide	“Front input guide removal” on page 212
7	40X8300	1	1	MPF solenoid	“MPF solenoid removal” on page 171
8	40X8301	1	1	Reverse solenoid	“Reverse solenoid removal” on page 177
9	40X8292	1	1	Control panel assembly	“Control panel assembly removal” on page 199

Assembly 3: Electronics 2

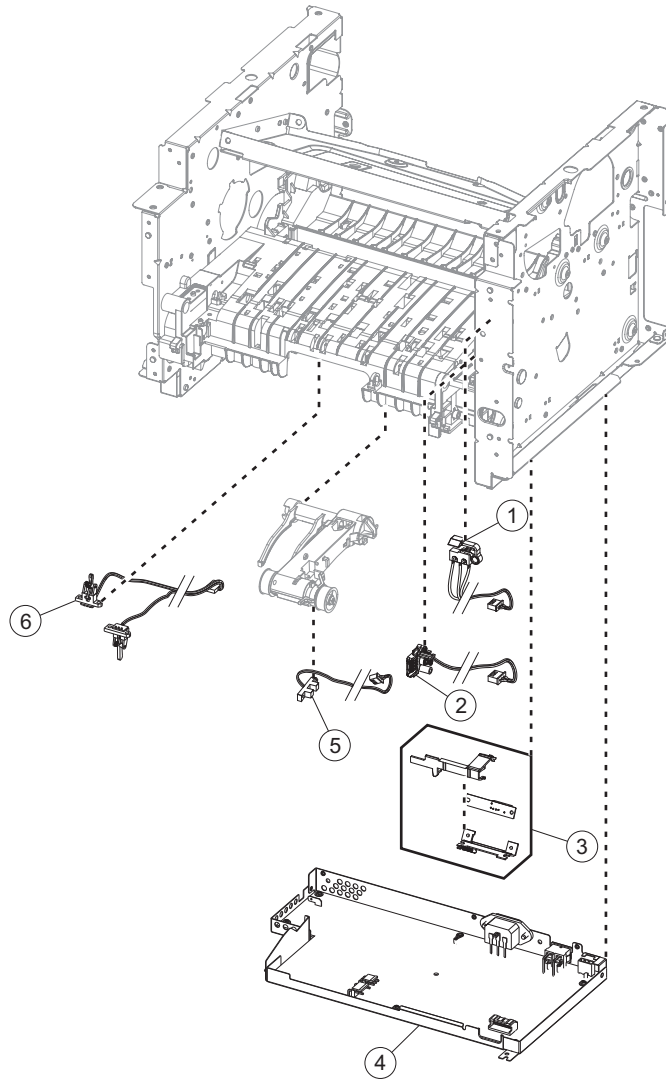

Assembly 3: Electronics 2

Asm-index	P/N	Units/mach	Units/FRU	Description	Removal procedure
1	40X8048	1	1	Front door sensor	“Front door sensor removal” on page 211
2	40X8266	1	1	Toner cartridge smart chip contact	“Toner cartridge smart chip contact removal” on page 188
3	40X8046	1	1	Toner density sensor	“Toner density sensor removal” on page 221
4	40X7795	1	1	Power supply, 100 V/110 V	“Power supply removal” on page 216
4	40X7796	1	1	Power supply, 220 V	“Power supply removal” on page 216
5	40X8047	1	1	Trailing edge sensor	“Trailing edge sensor removal” on page 222
6	40X8043	1	1	Duplex sensor and input sensor	“Duplex sensor and input sensor removal” on page 219

Assembly 4: Frame

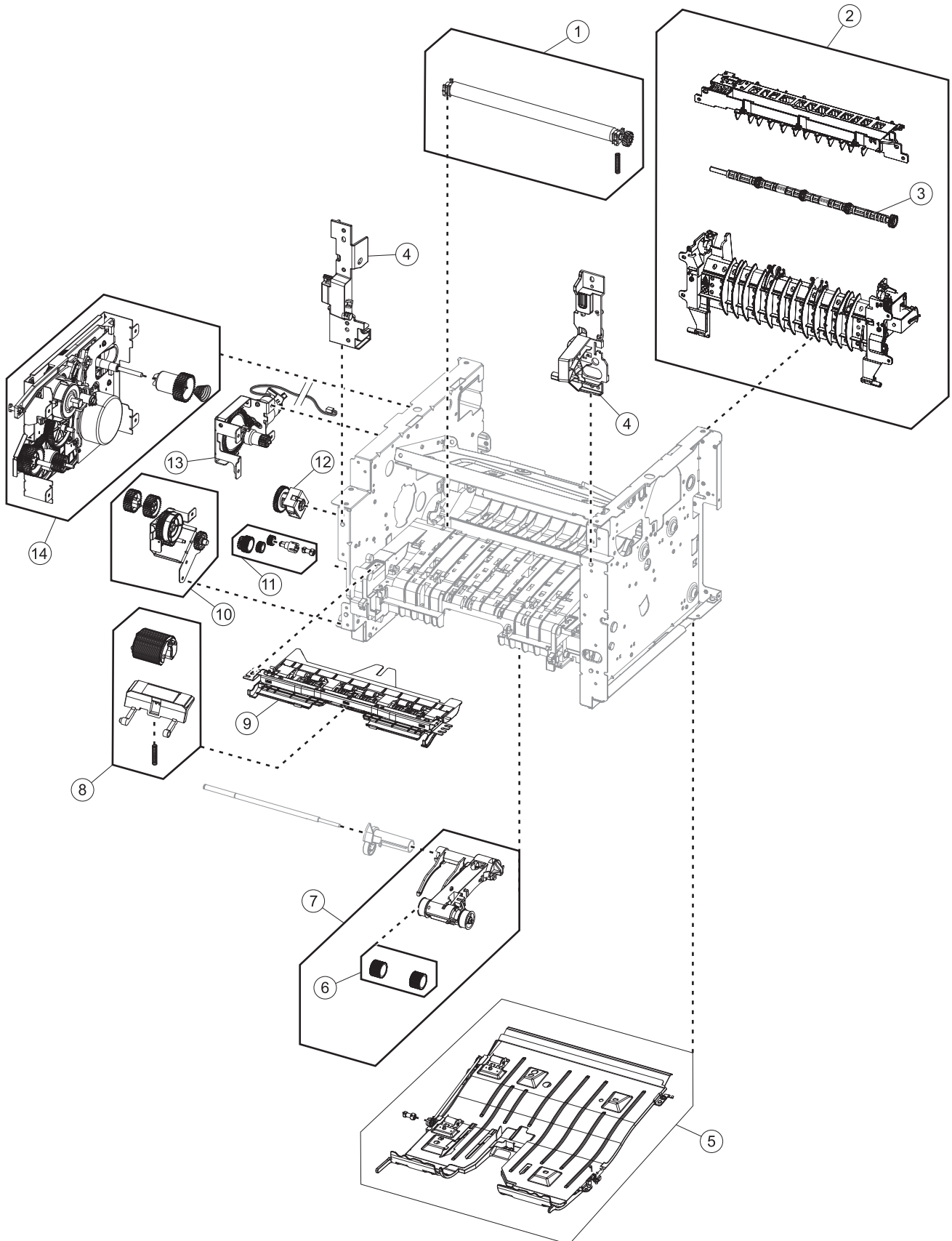

Assembly 4: Frame

Asm-index	P/N	Units/mach	Units/FRU	Description	Removal procedure
1	40X8393	1	1	Transfer roll	“Transfer roll removal” on page 194
2	40X8298	1	1	Redrive assembly	“Redrive assembly removal” on page 235
3	40X8850	1	1	Redrive shaft	“Redrive shaft removal” on page 236
4	40X8299	1	1	Front mounts	“Left front mount removal” on page 190 “Right front mount removal” on page 192
5	40X8275	1	1	Duplex assembly	“Duplex removal” on page 218
6	40X8296	2	2	Pick tires	N/A
7	40X8260	1	1	ACM assembly	“ACM assembly removal” on page 226
8	40X8295	1	1	MPF pick roller and Separator pad	“MPF pick roller removal” on page 206 “Separator pad removal” on page 214
9	40X8279	1	1	Jam access cover	“Jam access cover removal” on page 207
10	40X8278	1	1	MPF gearbox	“MPF gearbox removal” on page 174
11	40X8277	1	1	Duplex gear assembly	“Duplex gear assembly removal” on page 183
12	40X8265	1	1	ACM clutch, includes: <ul style="list-style-type: none"> Insulated displacement connector (IDC), 40X8682—2 pieces 	“ACM clutch removal” on page 178
13	40X8083	1	1	Cartridge gearbox	“Cartridge gearbox removal” on page 183
14	40X8085	1	1	Main drive gearbox	“Main drive gearbox removal” on page 169
NS	40X8394	1	1	Screw kit, contains: <ul style="list-style-type: none"> MT3x0.5+8PF-NI—10 pieces MT3x0.5+6PF-NI—10 pieces TP2NC-3+6PF-NI—10 pieces 	N/A

Assembly 5: Option trays

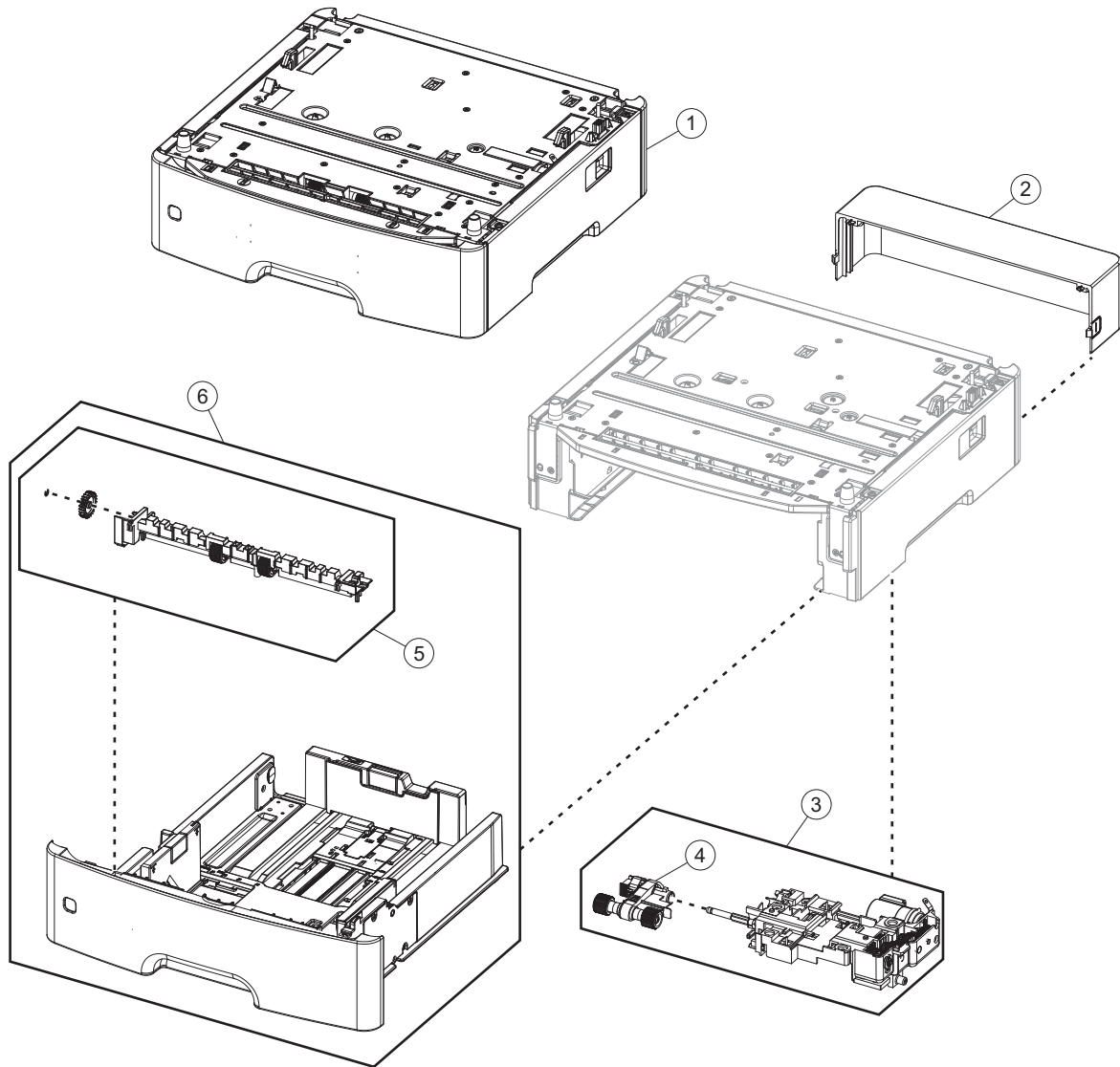

Assembly 5: Option trays

Asm-index	P/N	Units/opt	Units/FRU	Description	Removal procedure
1	40X8287	1	1	250-sheet tray	N/A
1	40X8286	1	1	550-sheet tray	N/A
1	40X9654	1	1	550-sheet tray, lockable	N/A
2	40X8520	1	1	Dust cover, 250-sheet tray	“Dust cover removal” on page 232
2	40X8521	1	1	Dust cover, 550-sheet tray	“Dust cover removal” on page 232
3	40X8262	1	1	ACM assembly	“ACM assembly removal” on page 245
4	40X8443	1	1	Pick roller assembly	“Pick roller removal” on page 242
5	40X8444	1	1	Separator roll assembly	“Separator roll assembly removal” on page 243
6	40X8305	1	1	250-sheet tray insert	N/A
6	40X8086	1	1	550-sheet tray insert	N/A

Assembly 6: Power cords

Asm-index	P/N	Units/mach	Units/FRU	Description	Removal procedure
NS	40X0269	1	1	Power cord, 2.5 m (straight)—USA, Canada	N/A
NS	40X3141	1	1	Power cord, 2.5 m (straight)—Europe and others	N/A
NS	40X0288	1	1	Power cord, 2.5 m (straight)—Argentina	N/A
NS	40X0271	1	1	Power cord, 2.5 m (straight)—United Kingdom	N/A
NS	40X0275	1	1	Power cord, 2.5 m (straight)—Israel	N/A
NS	40X1772	1	1	Power cord, 2.5 m (straight)—Switzerland	N/A
NS	40X1773	1	1	Power cord, 2.5 m (straight)—South Africa	N/A
NS	40X0273	1	1	Power cord, 2.5 m (straight)—Traditional Italy	N/A
NS	40X1774	1	1	Power cord, 2.5 m (straight)—Denmark	N/A
NS	40X4596	1	1	Power cord, 2.5 m (straight)—Brazil	N/A
NS	40X0303	1	1	Power cord, 2.5 m (straight)—China	N/A
NS	40X0270	1	1	Power cord, 2.5 m (straight)—Japan	N/A
NS	40X1792	1	1	Power cord, 2.5 m (straight)—Korea	N/A
NS	40X1791	1	1	Power cord, 2.5 m (straight)—Taiwan	N/A
NS	40X0301	1	1	Power cord, 2.5 m (straight)—Australia	N/A

Assembly 7: Miscellaneous

Asm-index	P/N	Units/mach	Units/FRU	Description	Removal procedure
NS	40X8737	1	1	RFID card reader	N/A
NS	40X8330	1	1	MarkNet N8352 802.11 b/g/n Wireless Print Server Kit	N/A
NS	40X8570	1	1	Font card, Arabic	N/A
NS	40X8571	1	1	Font card, Hebrew	N/A
NS	40X8568	1	1	Font card, Korean	N/A
NS	40X8569	1	1	Font card, Japanese	N/A
NS	40X8556	1	1	Font card, Traditional Chinese	N/A
NS	40X8557	1	1	Font card, Simplified Chinese	N/A
NS	40X8555	1	1	256MB flash card	N/A
NS	40X1368	1	1	USB cable, packaged (2 m)	N/A
NS	40X8694	1	1	Relocation kit	N/A

