

PARTS CATALOG

**MF6780/5980/5960/5950/
5940/5930, D1380/1370/
1350/1320**

Canon

Sep 9 2011

PREFACE

This Parts Catalog contains listings of parts used

Diagrams are provided with the listings to aid the service technician in identifying clearly, the item to be ordered.

Whenever ordering parts, consult this Parts Catalog for all of the information pertaining to each item. Be sure to include, in the Parts Request, the full item description, the item part number, and the quantity.

COPYRIGHT (C) 1999 CANON INC.

Use of this manual should be strictly supervised to avoid disclosure of confidential information.

Contents

NUMERICAL INDEX

MF6780/5980/5960/5950/5940/5930, D1380/1370/1350/1320(Numerical Index)..... 1-1

MF6780/5980/5960/5950/5940/5930, D1380/1370/1350/1320(Parts Catalog)

A1	ASSEMBLY LOCATION DIAGRAM	2-1
A2	OPTION PARTS CATALOG LIST	2-2
001	ACCESSORIES	2-3
100	EXTERNAL COVERS, PANELS, ETC.(MF5900 Series)	2-6
100A	EXTERNAL COVERS, PANELS, ETC.(EXCEPT MF5900 Series) 2-10	
101	INTERNAL COMPONENTS 1	2-14
102	INTERNAL COMPONENTS 2	2-16
103	INTERNAL COMPONENTS 3	2-18
104	INTERNAL COMPONENTS 4	2-20
105	INTERNAL COMPONENTS 5	2-22
106	INTERNAL COMPONENTS 6 (MF5900 Series)	2-24
106A	INTERNAL COMPONENTS 6 (EXCEPT MF5900 Series) ..	2-26
160	READER/ADF ASSEMBLY (MF5900 Series)	2-28
160A	READER/ADF ASSEMBLY (EXCEPT MF5900 Series)	2-31
162	PAPER FEEDER ASSEMBLY	2-34
400	READER ASSEMBLY (MF5900 Series)	2-37
400A	READER ASSEMBLY (EXCEPT MF5900 Series)	2-39
ZZA	MECHANICAL STANDARD PARTS (HOW TO USE)	2-41
ZZB	MECHANICAL STANDARD PARTS (SCREWS)	2-42
ZZC	MECHANICAL STANDARD PARTS (BOLTS)	2-49
ZZD	MECHANICAL STANDARD PARTS (NUTS)	2-50
ZZE	MECHANICAL STANDARD PARTS (RETAINING RINGS) ..	2-51

NUMERICAL INDEX

MF6780/5980/5960/5950/5940/5930, D1380/1370/1350/1320(Numerical Index)

PARTS NUMBER	FIGURE & KEY NO.	PARTS NUMBER	FIGURE & KEY NO.	PARTS NUMBER	FIGURE & KEY NO.
FC0-0531-000	100 - 1	FC9-1536-000	160 - 11	FC9-8944-000	100A - 11
FC0-3108-000	100A - 27	FC9-1537-000	162 - 34	FH2-7080-000	001 - 13
FC0-3132-000	100A - 5	FC9-1539-000	160 - 12	FH2-7082-000	001 - 15
FC0-3133-000	100A - 7	FC9-2007-000	100A - 3	FH2-7170-000	001 - 17
FC0-3136-000	100 - 5	FC9-2016-000	100A - 24	FK2-1311-000	001 - 16
FC0-3162-000	100A - 7	FC9-2055-000	100A - 8	FK2-2064-000	104 - 2
FC0-3163-000	100 - 9	FC9-2056-000	100A - 9	FK2-4390-000	001 - 12
FC0-3182-000	105 - 1	FC9-2068-000	106A - 1	FK2-5274-000	001 - 2
FC0-3192-000	100 - 11	FC9-2069-000	106A - 2	FK2-9583-000	001 - 14
FC0-3196-000	100A - 15	FC9-2071-000	106A - 3	FK3-0730-000	103 - 6
FC0-3200-000	001 - 4	FC9-2131-000	100 - 2	FK3-0732-000	104 - 3
FC0-3201-000	001 - 3	FC9-2132-000	100 - 3	FK3-1626-000	105 - 4
FC0-4141-000	100A - 27	FC9-2135-000	100 - 4	FK3-1820-000	105 - 8
FC0-4142-000	100A - 27	FC9-2137-000	100 - 6	FK3-1821-000	105 - 10
FC0-4143-000	100A - 27	FC9-2138-000	100 - 7	FK3-1826-000	105 - 3
FC0-4144-000	100A - 27	FC9-2139-000	100 - 8	FK3-1904-000	400 - 4
FC0-4145-000	100A - 27	FC9-2142-000	104 - 1	FK3-1904-000	400A - 4
FC0-4146-000	100 - 9	FC9-2166-000	100A - 12	FK3-1907-000	400 - 9
FC0-4147-000	100 - 9	FC9-2190-000	001 - 5	FK3-1908-000	400A - 9
FC0-4148-000	100 - 9	FC9-4891-000	106A - 4	FK3-2783-000	001 - 1
FC0-4149-000	100 - 9	FC9-4897-000	100 - 13	FK3-2785-000	001 - 1
FC0-4168-000	100A - 2	FC9-4897-000	100A - 18	FK3-2786-000	001 - 1
FC0-4169-000	100A - 10	FC9-4998-000	160A - 6	FK3-2787-000	001 - 1
FC0-4170-000	100A - 4	FC9-4999-000	160A - 13	FK3-2788-000	001 - 1
FC0-4173-000	100 - 15	FC9-5109-000	160 - 13	FK3-2789-000	001 - 1
FC0-4177-000	400A - 10	FC9-5110-000	160A - 7	FK3-2790-000	001 - 1
FC0-6761-000	100A - 20	FC9-5111-000	160 - 5	FK3-2791-000	001 - 1
FC5-5256-000	100A - 1	FC9-5111-000	160A - 8	FK3-2793-000	001 - 1
FC7-0496-000	100A - 1	FC9-5115-000	160A - 7	FK3-2794-000	001 - 1
FC7-6052-010	162 - 1	FC9-5654-000	162 - 6	FK3-2796-000	001 - 1
FC7-6182-000	162 - 2	FC9-5655-000	160 - 14	FK3-2797-000	001 - 1
FC7-6189-000	160 - 1	FC9-5660-000	160A - 15	FK3-2798-000	001 - 1
FC7-6189-000	160A - 1	FC9-5661-000	160A - 16	FL2-6637-000	160 - 19
FC7-6278-000	162 - 3	FC9-7005-000	100 - 14	FL2-6637-000	160A - 19
FC7-6281-000	162 - 4	FC9-7005-000	100A - 20	FL3-1430-000	160A - 19
FC7-6297-000	162 - 5	FC9-7562-000	160 - 17	FL3-1431-000	162 - 10
FC7-6299-000	162 - 7	FC9-7563-000	160 - 17	FL3-1437-000	162 - 11
FC7-6300-000	162 - 8	FC9-7564-000	160 - 17	FL3-1439-000	160A - 20
FC7-6320-000	160 - 2	FC9-7566-000	160 - 18	FL3-2453-000	160 - 20
FC7-6320-000	160A - 2	FC9-7567-000	160 - 18	FL3-2458-000	162 - 18
FC7-6321-000	160 - 3	FC9-7568-000	160 - 18	FL3-3539-000	160 - 21
FC7-6321-000	160A - 3	FC9-7574-000	400 - 3	FL3-3539-000	160A - 18
FC8-9837-000	100 - 29	FC9-7574-000	400A - 3	FL3-5849-000	400A - 2
FC9-1486-000	160A - 7	FC9-7575-000	160 - 13	FL3-5850-000	400 - 2
FC9-1494-000	160 - 5	FC9-7576-000	160 - 13	FL3-5852-000	100A - 6
FC9-1494-000	160A - 8	FC9-8934-000	100 - 16	FL3-5854-000	100 - 10
FC9-1496-000	160A - 5	FC9-8934-000	100A - 13	FM3-8839-000	106 - 1
FC9-1499-000	160A - 9	FC9-8941-000	100 - 19	FM3-9088-000	101 - 2
FC9-1512-000	162 - 9	FC9-8942-000	104 - 15	FM3-9538-000	160 - 22
FC9-1532-000	160 - 7	FC9-8943-000	100 - 20	FM3-9538-000	160A - 23
FC9-1533-000	160 - 8	FC9-8943-000	100A - 14	FM3-9541-000	162 - 13
FC9-1535-000	160 - 10	FC9-8944-000	100 - 21	FM3-9542-000	162 - 14

NUMERICAL INDEX

MF6780/5980/5960/5950/5940/5930, D1380/1370/1350/1320(Numerical Index)

PARTS NUMBER	FIGURE & KEY NO.	PARTS NUMBER	FIGURE & KEY NO.	PARTS NUMBER	FIGURE & KEY NO
FM3-9543-000	162 - 15	FM4-9765-000	100 - 26	NPN	104 -
FM3-9791-000	100 - 23	FM4-9766-000	100 - 26	NPN	105 -
FM3-9791-000	100A - 21	FM4-9767-000	100 - 26	NPN	106 -
FM3-9793-000	100 - 24	FM4-9770-000	100A - 25	NPN	106A -
FM3-9793-000	100A - 22	FM4-9771-000	100A - 25	NPN	160 -
FM3-9797-000	101 - 1	FM4-9772-000	100A - 25	NPN	160A -
FM3-9798-000	106A - 6	FM4-9773-000	100A - 25	NPN	162 -
FM3-9816-000	100 - 25	FM4-9774-000	100A - 25	QK1-6441-000	001 - 8
FM3-9816-000	100A - 26	FM4-9775-000	100A - 25	QK1-6443-000	001 - 9
FM4-1605-000	104 - 16	FM4-9783-000	100A - 23	QK1-6446-000	001 - 10
FM4-1873-000	162 - 17	FM4-9787-000	102 - 10	QK1-6449-000	001 - 11
FM4-1876-000	160 - 4	FM4-9826-000	100 - 26	QK1-6455-000	001 - 7
FM4-1883-000	160 - 26	FM4-9829-000	100A - 22	RC2-1568-000	104 - 18
FM4-1883-000	160A - 26	FM4-9831-000	105 - 11	RC2-6130-000	102 - 1
FM4-1885-000	162 - 12	FU5-6992-000	162 - 19	RC2-6273-000	100 - 17
FM4-1888-000	160A - 21	FU6-2998-000	162 - 20	RC2-6273-000	100A - 28
FM4-2097-000	001 - 18	FU6-2999-000	162 - 21	RC2-8291-000	100 - 18
FM4-3989-000	104 - 4	FU7-0667-000	162 - 22	RC2-8291-000	100A - 29
FM4-4308-000	400 - 5	FU7-0668-000	162 - 23	RK2-2729-000	104 - 6
FM4-5367-000	102 - 10	FU7-0669-000	162 - 24	RK2-2731-000	104 - 7
FM4-5370-000	100 - 27	FU7-0671-000	162 - 25	RK2-2733-000	104 - 8
FM4-5386-000	102 - 11	FU7-0672-000	160 - 24	RL1-2111-000	101 - 8
FM4-6601-000	400 -	FU7-0672-000	160A - 24	RL1-2112-000	101 - 9
FM4-8841-000	400A -	FU7-0676-000	162 - 26	RL1-2115-000	102 - 4
FM4-8853-000	162 - 16	FU7-0678-000	162 - 27	RL1-2120-000	104 - 9
FM4-8946-000	105 - 6	FU7-2016-000	162 - 28	RM1-1301-000	102 - 5
FM4-8947-000	105 - 6	FU7-2018-000	160 - 25	RM1-4275-000	104 - 10
FM4-8963-000	105 - 7	FU7-2018-000	160A - 25	RM1-6350-000	102 - 6
FM4-8964-000	105 - 7	FU7-2021-000	162 - 29	RM1-6378-000	102 - 7
FM4-8965-000	105 - 7	FU7-8091-000	100A - 16	RM1-6397-000	106 - 2
FM4-8967-000	105 - 5	FU7-8986-000	160A - 14	RM1-6401-000	101 - 3
FM4-8968-000	105 - 5	FU7-8987-000	160A - 14	RM1-6402-000	103 - 1
FM4-9008-000	105 - 9	FU7-8988-000	160A - 14	RM1-6405-000	101 - 2
FM4-9009-000	104 - 5	FU8-2008-000	162 - 30	RM1-6406-000	101 - 2
FM4-9010-000	104 - 5	HB1-4978-000	001 - 19	RM1-6414-000	102 - 8
FM4-9011-000	104 - 5	HB1-5537-000	100 - 12	RM1-6419-000	103 - 2
FM4-9012-000	104 - 5	HB1-5537-000	100A - 17	RM1-6421-000	101 - 1
FM4-9055-000	102 - 11	HC1-0586-000	160 - 23	RM1-6423-000	104 - 11
FM4-9070-000	400 - 6	HC1-0586-000	160A - 22	RM1-6424-000	103 - 3
FM4-9071-000	400A - 6	HC1-0586-000	162 - 31	RM1-6427-000	100 - 31
FM4-9072-000	400A - 5	HC1-2034-000	001 - 20	RM1-6427-000	100A - 30
FM4-9208-000	105 - 6	HH2-2824-000	001 - 6	RM1-6441-000	100 - 30
FM4-9209-000	105 - 6	HK1-0516-010	001 - 18	RM1-6441-000	100A - 32
FM4-9210-000	105 - 6	HU1-1022-000	160 - 15	RM1-6445-000	101 - 4
FM4-9211-000	105 - 6	HU1-1022-000	160A - 12	RM1-6450-000	103 - 7
FM4-9212-000	105 - 6	HU1-1022-000	162 - 32	RM1-6454-000	106A - 7
FM4-9213-000	105 - 6	NPN	001 -	RU5-2895-000	100 - 28
FM4-9214-000	105 - 6	NPN	100 -	RU5-2895-000	100A - 31
FM4-9761-000	100 - 26	NPN	100A -	RU5-2898-000	102 - 3
FM4-9762-000	100 - 26	NPN	101 -	RU6-2610-000	101 - 7
FM4-9763-000	100 - 26	NPN	102 -	VS1-7177-002	160 - 6
FM4-9764-000	100 - 26	NPN	103 -	VS1-7177-002	160A - 4

NUMERICAL INDEX

MF6780/5980/5960/5950/5940/5930, D1380/1370/1350/1320(Numerical Index)

PARTS NUMBER	FIGURE & KEY NO.	PARTS NUMBER	FIGURE & KEY NO.	PARTS NUMBER	FIGURE & KEY NO.
VS1-7177-003	104 - 12				
VS1-7177-004	400 - 1				
VS1-7177-004	400A - 1				
VS1-7207-004	160 - 9				
VS1-7207-004	160A - 10				
WC4-5171-000	104 - 13				
WG8-5696-000	162 - 33				
WG8-5696-000	400 - 7				
WG8-5696-000	400A - 7				
XA9-0476-000	400 - 8				
XA9-0476-000	400A - 8				
XA9-0831-000	160 - 16				
XA9-0831-000	160A - 11				
XA9-0994-000	102 - 2				
XA9-1420-000	103 - 4				
XA9-1503-000	101 - 5				
XA9-1503-000	104 - 17				
XA9-1671-000	100 - 22				
XA9-1671-000	100A - 19				
XA9-1671-000	101 - 6				
XA9-1671-000	102 - 9				
XA9-1671-000	103 - 5				
XA9-1671-000	104 - 14				
XA9-1671-000	105 - 2				
XA9-1671-000	106 - 3				
XA9-1671-000	106A - 5				
XD1-3100-407	102 - 501				
XD3-2300-322	101 - 501				
XD9-0219-000	160 - 501				
XD9-0219-000	160A - 501				

MF6780/5980/5960/5950/5940/5930, D1380/1370/1350/1320(Parts Catalog)

imageCLASS MF5980dw

120V CA,LTN	F16-1334-000	HQY	FAX/WIRELESS model
230V LTN,SG	F16-1344-000	HQN	FAX/WIRELESS model
230V AU	F16-1384-000	HQP	FAX/WIRELESS model

imageCLASS MF5960dn

120V US	F16-1333-000	HQG	FAX model
120V CA,LTN	F16-1333-000	HQH	FAX model

imageCLASS MF5950dw

120V US	F16-1332-000	HPY	FAX/WIRELESS model
120V CA,LTN	F16-1332-000	HQA	FAX/WIRELESS model
230V CN	F16-1352-000	HQE	FAX/WIRELESS model
230V KR	F16-1362-000	HQC	FAX/WIRELESS model

imageCLASS D1380

230V CN	F16-1455-000	HQX	FAX/WIRELESS model
----------------	---------------------	------------	---------------------------

imageCLASS D1370

120V US	F16-1433-000	HQV	FAX model
----------------	---------------------	------------	------------------

imageCLASS D1350

120V TW	F16-1422-000	HQU	FAX model
----------------	---------------------	------------	------------------

120V US	F16-1432-000	HQS	FAX model
----------------	---------------------	------------	-----------

120V CA,LTN	F16-1432-000	HQT	FAX model
--------------------	---------------------	------------	-----------

imageCLASS D1320

120V US	F16-1431-000	HQR	
----------------	---------------------	------------	--

i-SENSYS MF5980dw

230V EUR1	F16-1394-000	HQK	FAX/WIRELESS model
------------------	---------------------	------------	--------------------

230V EUR2	F16-1394-000	HQL	FAX/WIRELESS model
------------------	---------------------	------------	--------------------

230V EUR3	F16-1394-000	HQM	FAX/WIRELESS model
------------------	---------------------	------------	--------------------

i-SENSYS MF5940dn

230V EUR1	F16-1391-000	HPQ	FAX model
------------------	---------------------	------------	-----------

230V EUR2	F16-1391-000	HPR	FAX model
------------------	---------------------	------------	-----------

230V EUR3	F16-1391-000	HPX	FAX model
------------------	---------------------	------------	-----------

Satera MF6780dw

100V JP	F16-1414-000	HQW	FAX/WIRELESS model
----------------	---------------------	------------	--------------------

Contents

A1	ASSEMBLY LOCATION DIAGRAM	2-1
A2	OPTION PARTS CATALOG LIST	2-2
001	ACCESSORIES	2-3
100	EXTERNAL COVERS, PANELS, ETC.(MF5900 Series).....	2-6
100A	EXTERNAL COVERS, PANELS, ETC.(EXCEPT MF5900 Series)	2-10
101	INTERNAL COMPONENTS 1	2-14
102	INTERNAL COMPONENTS 2	2-16
103	INTERNAL COMPONENTS 3	2-18
104	INTERNAL COMPONENTS 4	2-20
105	INTERNAL COMPONENTS 5	2-22
106	INTERNAL COMPONENTS 6 (MF5900 Series).....	2-24
106A	INTERNAL COMPONENTS 6 (EXCEPT MF5900 Series)	2-26
160	READER/ADF ASSEMBLY (MF5900 Series).....	2-28
160A	READER/ADF ASSEMBLY (EXCEPT MF5900 Series)	2-31
162	PAPER FEEDER ASSEMBLY	2-34
400	READER ASSEMBLY (MF5900 Series).....	2-37
400A	READER ASSEMBLY (EXCEPT MF5900 Series).....	2-39
ZZA	MECHANICAL STANDARD PARTS (HOW TO USE)	2-41
ZZB	MECHANICAL STANDARD PARTS (SCREWS).....	2-42
ZZC	MECHANICAL STANDARD PARTS (BOLTS).....	2-49
ZZD	MECHANICAL STANDARD PARTS (NUTS).....	2-50
ZZE	MECHANICAL STANDARD PARTS (RETAINING RINGS)	2-51

FIGURE A1 ASSEMBLY LOCATION DIAGRAM

MF5900 Series

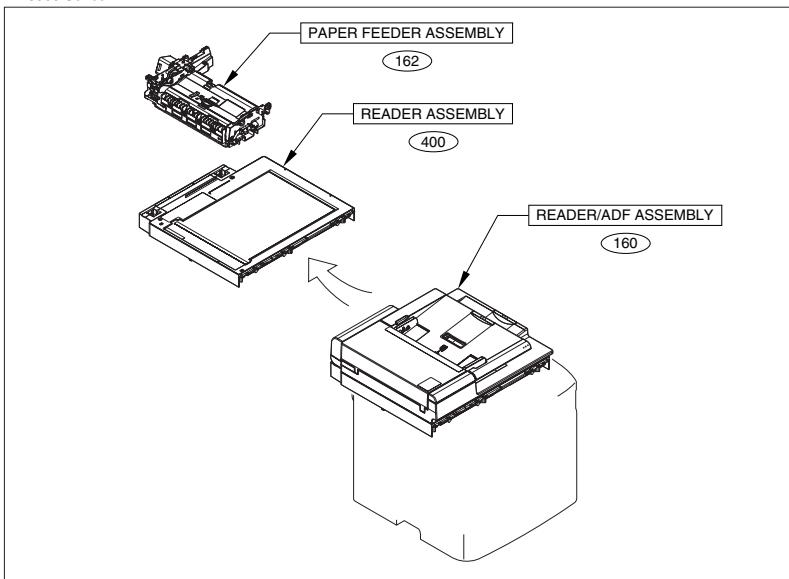

EXCEPT MF5900 Series

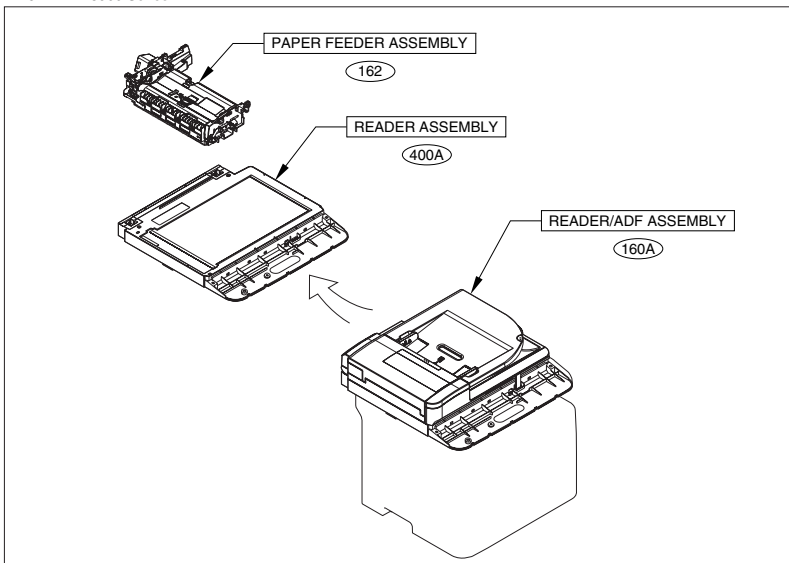

FIGURE A2 OPTION PARTS CATALOG LIST

This is the table of the machine's options whose parts catalog is issued.
本機のオプションで、パーツカタログが発行されている機種の一覧である。

No.	Model Name(English)	Model Name(Japanese)
1	Paper Feeder Unit PF-44	ペーパーフィーダーユニット PF-44
2	Cassette Feeding Module-U1	1段カセットユニット・U1
3	TELEPHONE 6 KIT Long cord	(日本仕向けなし)
4	(JAPAN ONLY)	ハンドセットキット L11

FIGURE 001 ACCESSORIES

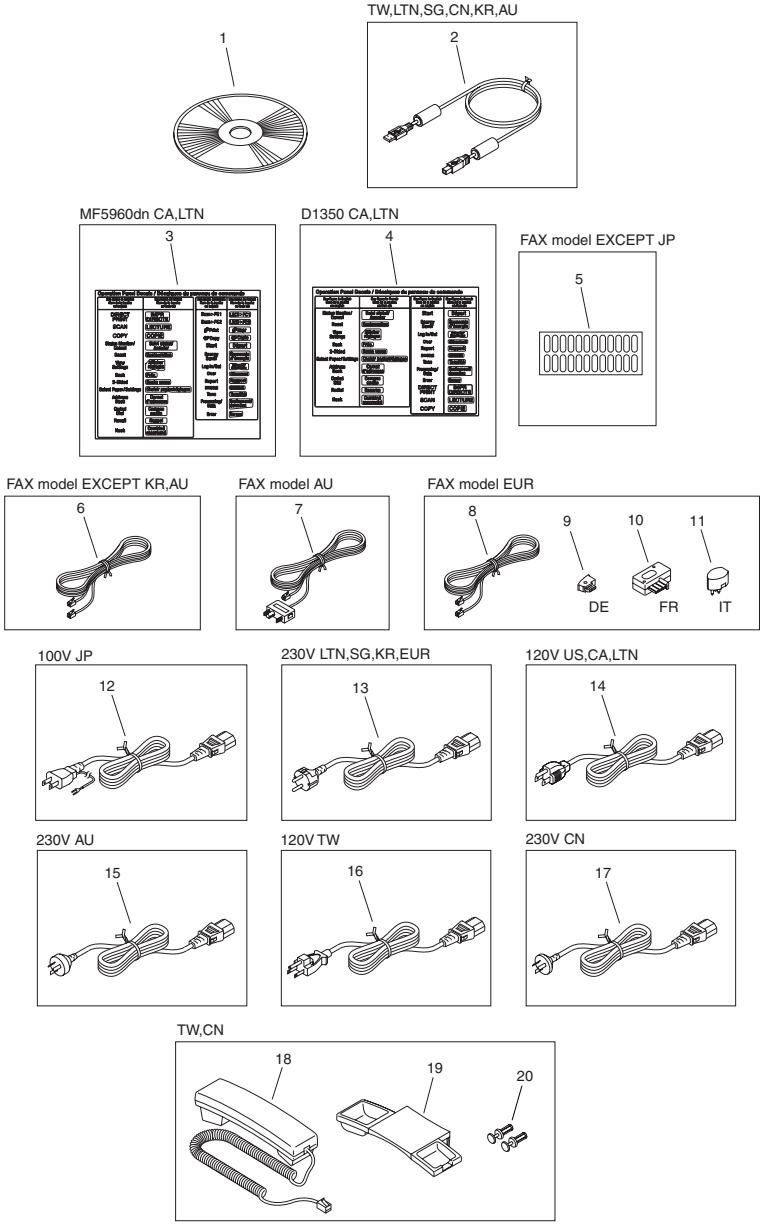
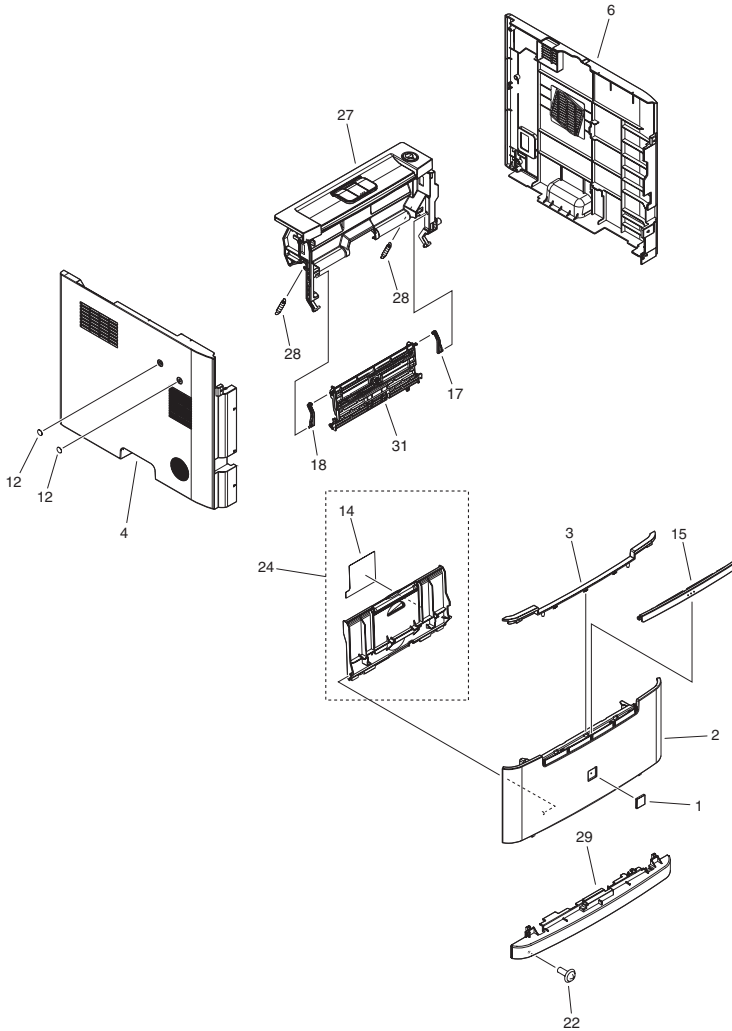

FIGURE & KEY NO.	PARTS NUMBER	RANK	Q'TY	DESCRIPTION	SERIAL NUMBER/REMARKS	SVC
Fig.001	NPN		RF	ACCESSORIES		
1	FK3-2798-000		1	CD-ROM, USER SOFTWARE	MF6780dw	
1	FK3-2783-000		1	CD-ROM, USER SOFTWARE	MF5900 Series US English	
1	FK3-2791-000		1	CD-ROM, USER SOFTWARE	MF5900 Series US English for Mac OS	
1	FK3-2785-000		1	CD-ROM, USER SOFTWARE	MF5900 Series US English, Canadian French	
1	FK3-2789-000		1	CD-ROM, USER SOFTWARE	MF5900 Series English	
1	FK3-2790-000		1	CD-ROM, USER SOFTWARE	MF5900 Series English, Simplified Chinese, Traditional Chinese, Korean	
1	FK3-2786-000		1	CD-ROM, USER SOFTWARE	MF5900 Series English, French, Italian	
1	FK3-2787-000		1	CD-ROM, USER SOFTWARE	MF5900 Series English, German, Spanish	
1	FK3-2788-000		1	CD-ROM, USER SOFTWARE	MF5900 Series English, Russian, Dutch, Polish	
1	FK3-2796-000		1	CD-ROM, USER SOFTWARE	D1380, D1350 English, Simplified Chinese Traditional Chinese	
1	FK3-2794-000		1	CD-ROM, USER SOFTWARE	D1350 US English, Canadian French	
1	FK3-2793-000		1	CD-ROM, USER SOFTWARE	D1300 Series US English	
1	FK3-2797-000		1	CD-ROM, USER SOFTWARE	D1300 Series US English for Mac OS	
2	FK2-5274-000		1	CABLE, USB	TW,LTN,SG,CN,KR,AU	
3	FC0-3201-000		1	LABEL, CONTROL PANEL	MF5960dn CA,LTN	
4	FC0-3200-000		1	LABEL, CONTROL PANEL	D1350 CA,LTN	
5	FC9-2190-000		1	LABEL, DESTINATION	FAX model EXCEPT JP	
6	HH2-2824-000		1	MODULAR CORD, 2P	FAX model EXCEPT KR,AU	
7	QK1-6455-000		1	CORD, MODULAR	FAX model AU	
8	QK1-6441-000		1	CORD, MODULAR	FAX model EUR	
9	QK1-6443-000		1	PLUG	FAX model DE	
10	QK1-6446-000		1	PLUG	FAX model FR	
11	QK1-6449-000		1	PLUG	FAX model IT	

FIGURE & KEY NO.	PARTS NUMBER	R A N K	Q'TY	DESCRIPTION	SERIAL NUMBER/ REMARKS	S V C
12	FK2-4390-000		1	CORD, POWER	100V JP	
13	FH2-7080-000		1	CORD, POWER	230V LTN,SG,KR,EUR	
14	FK2-9583-000		1	CORD, POWER	120V US,CA,LTN	
15	FH2-7082-000		1	CORD, POWER	230V AU	
16	FK2-1311-000		1	CORD, POWER	120V TW	
17	FH2-7170-000		1	CORD, POWER	230V CN	
18	FM4-2097-000		1	HANDSET UNIT	TW	
18	HK1-0516-010		1	HANDSET UNIT	CN	
19	HB1-4978-000		1	HOLDER, HANDSET CRADLE	TW,CN	
20	HC1-2034-000		2	RIVET	TW,CN	

FIGURE 100 EXTERNAL COVERS, PANELS, ETC.(MF5900 Series)



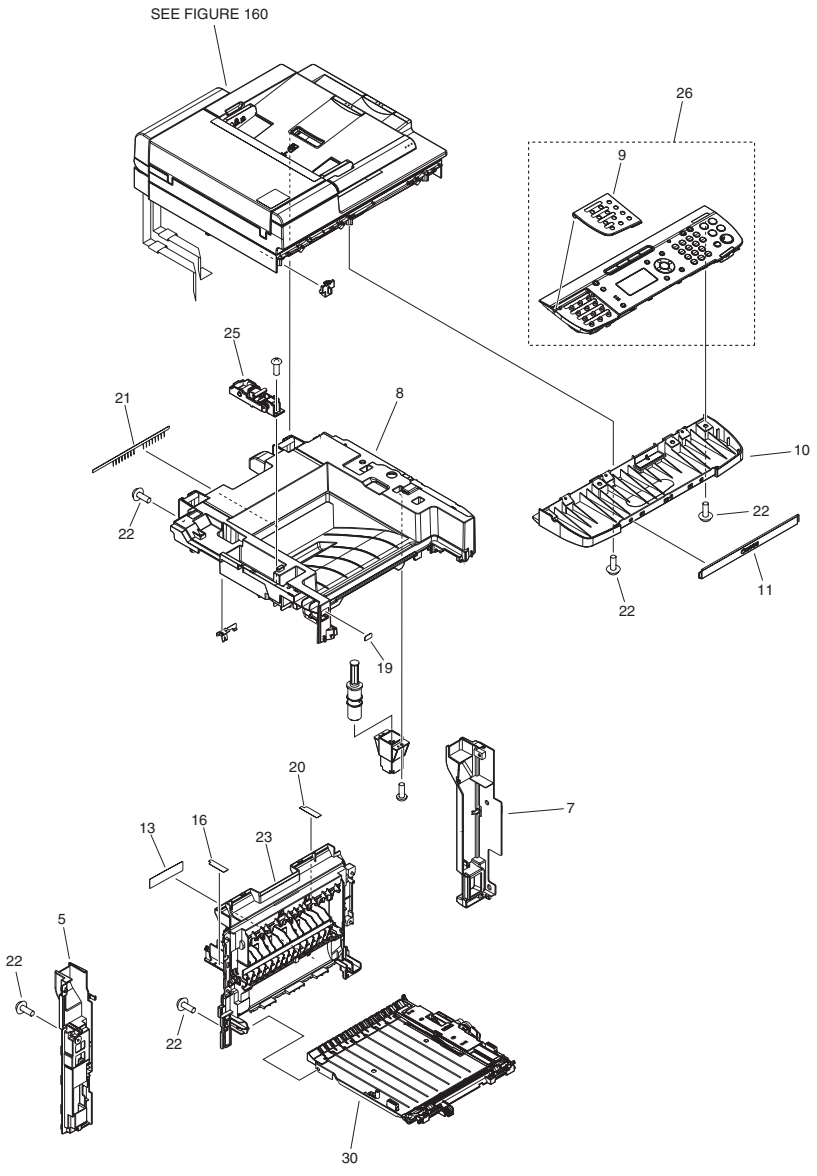
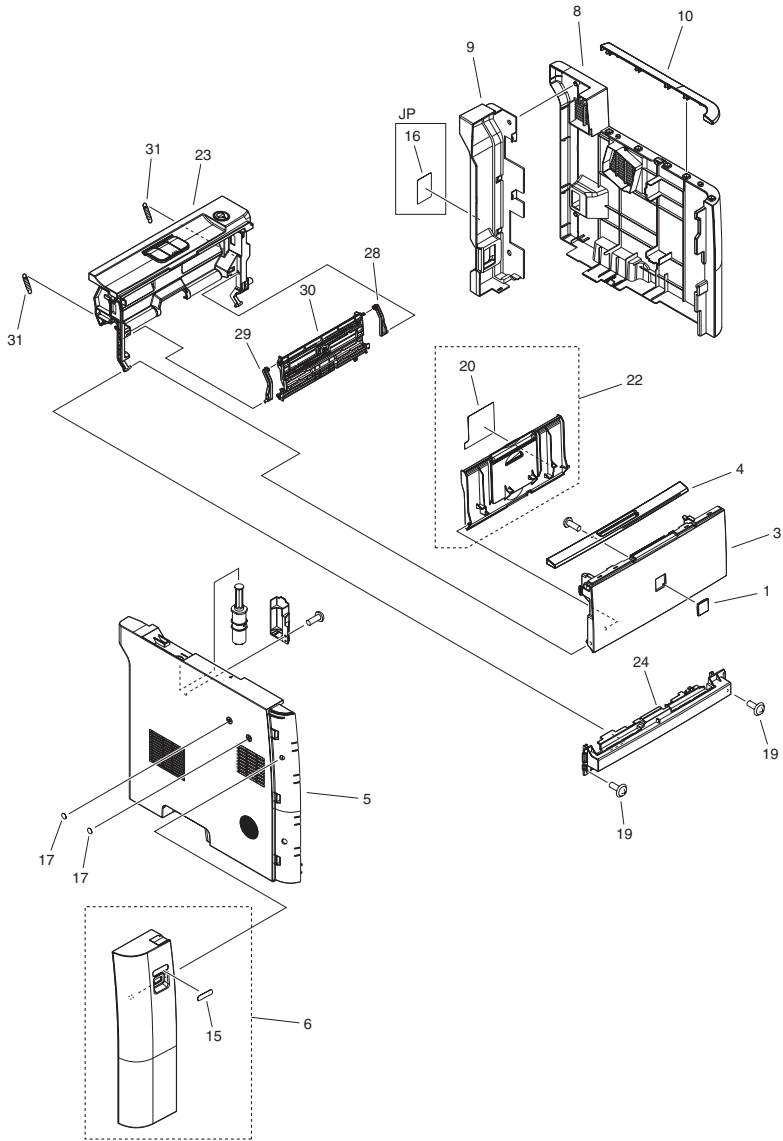

FIGURE & KEY NO.	PARTS NUMBER	R A N K	Q'TY	DESCRIPTION	SERIAL NUMBER/ REMARKS	S V C
Fig.100	NPN		RF	EXTERNAL COVERS, PANELS, ETC.	MF5900 Series	
1	FC0-0531-000		1	EMBLEM		
2	FC9-2131-000		1	COVER, MULTI FEED		
3	FC9-2132-000		1	COVER, FRONT UPPER, 2		
4	FC9-2135-000		1	COVER, LEFT		
5	FC0-3136-000		1	COVER, LEFT, REAR		
6	FC9-2137-000		1	COVER, RIGHT		
7	FC9-2138-000		1	COVER, REAR RIGHT		
8	FC9-2139-000		1	COVER, UPPER		
9	FC0-3163-000		1	COVER, ONE-TOUCH	US,CA,LTN	
9	FC0-4146-000		1	COVER, ONE-TOUCH	EUR	
9	FC0-4147-000		1	COVER, ONE-TOUCH	LTN,SG,AU	
9	FC0-4148-000		1	COVER, ONE-TOUCH	CN	
9	FC0-4149-000		1	COVER, ONE-TOUCH	KR	
10	FL3-5854-000		1	PANEL, CONTROL, LOWER		
11	FC0-3192-000		1	PLATE, LOGO		
12	HB1-5537-000		2	SHEET,BLANKING		
13	FC9-4897-000		1	LABEL, SIZE EXCHANGE		
14	FC9-7005-000		1	LABEL, SIZE, MANUAL FEED		
15	FC0-4173-000		1	COVER, FRONT UPPER, 1		
16	FC9-8934-000		1	LABEL, HIGH TMP. CAUTION		
17	RC2-6273-000		1	HINGE, MULTI-PURPOSE, RIGHT		
18	RC2-8291-000		1	HINGE, MULTI-PURPOSE, LEFT		
19	FC9-8941-000		1	LABEL, USB		
20	FC9-8943-000		1	LABEL, HIGH TMP. CAUTION		
21	FC9-8944-000		1	ELIMINATOR, STATIC CHARGE		
22	XA9-1671-000		AR	SCREW, D, M3X8		
23	FM3-9791-000		1	REAR COVER ASSEMBLY		
24	FM3-9793-000		1	EXPANSION TRAY ASSEMBLY		
25	FM3-9816-000		1	HINGE ASSEMBLY		
26	FM4-9761-000		1	CONTROL PANEL ASSEMBLY	MF5980dw CA,LTN	
26	FM4-9763-000		1	CONTROL PANEL ASSEMBLY	MF5980dw LTN,SG,AU	

FIGURE & KEY NO.	PARTS NUMBER	RANK	Q'TY	DESCRIPTION	SERIAL NUMBER/REMARKS	SVC
26	FM4-9765-000		1	CONTROL PANEL ASSEMBLY	MF5980dw EUR	
26	FM4-9762-000		1	CONTROL PANEL ASSEMBLY	MF5960dn	
26	FM4-9826-000		1	CONTROL PANEL ASSEMBLY	MF5950dw US,CA,LTN	
26	FM4-9766-000		1	CONTROL PANEL ASSEMBLY	MF5950dw CN	
26	FM4-9767-000		1	CONTROL PANEL ASSEMBLY	MF5950dw KR	
26	FM4-9764-000		1	CONTROL PANEL ASSEMBLY	MF5940dn	
27	FM4-5370-000		1	INNER COVER ASSEMBLY		
28	RU5-2895-000		2	SPRING, TENSION		
29	FC8-9837-000		1	COVER, FRONT		
30	RM1-6441-000		1	DUPLEXING PAPER FEED ASS'Y		
31	RM1-6427-000		1	MP LIFTING PLATE ASSEMBLY		

FIGURE 100A
EXTERNAL COVERS, PANELS, ETC.(EXCEPT
MF5900 Series)



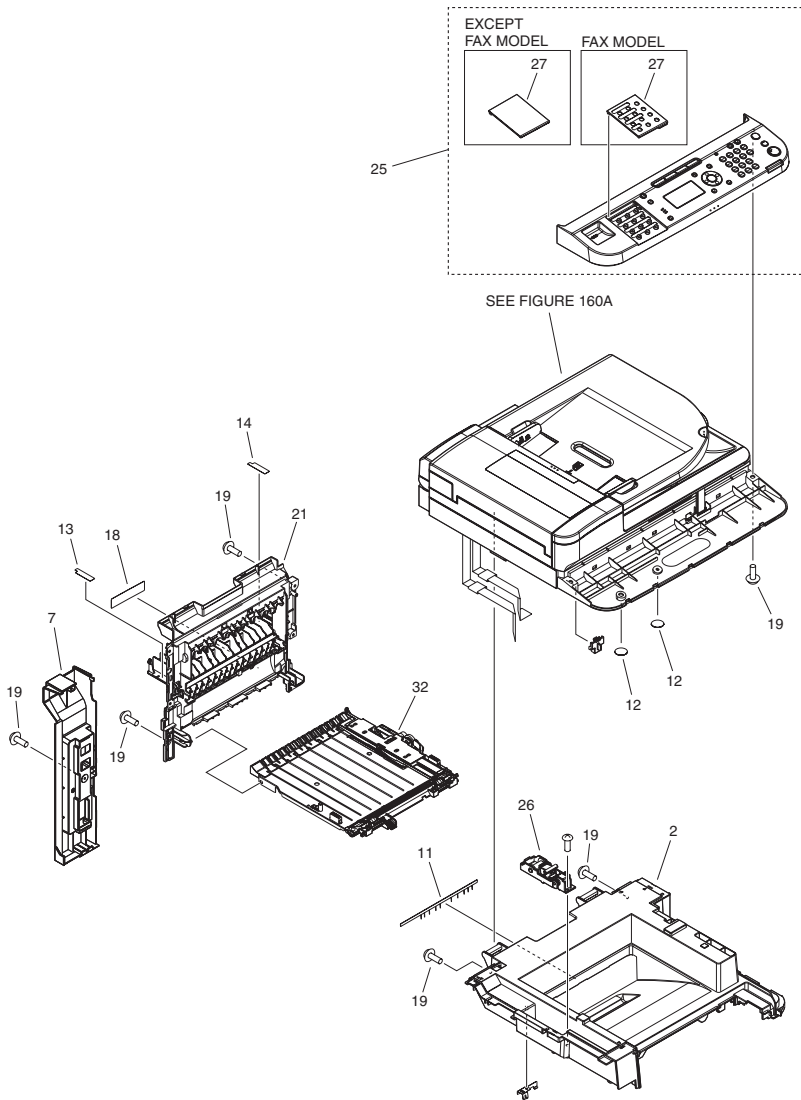

FIGURE & KEY NO.	PARTS NUMBER	RANK	Q'TY	DESCRIPTION	SERIAL NUMBER/REMARKS	SVC
Fig.100A	NPN		RF	EXTERNAL COVERS, PANELS, ETC.	EXCEPT MF5900 Series	
1	FC5-5256-000		1	EMBLEM	Satera MF6780dw	
1	FC7-0496-000		1	EMBLEM	EXCEPT JP	
2	FC0-4168-000		1	COVER, UPPER		
3	FC9-2007-000		1	COVER, MULTI FEED		
4	FC0-4170-000		1	COVER, MULTI FEED UPPER		
5	FC0-3132-000		1	COVER, LEFT		
6	FL3-5852-000		1	COVER, FRONT, LEFT		
7	FC0-3133-000		1	COVER, LEFT, REAR	FAX model	
7	FC0-3162-000		1	COVER, LEFT, REAR	EXCEPT FAX model US	
8	FC9-2055-000		1	COVER, RIGHT		
9	FC9-2056-000		1	COVER, REAR RIGHT		
10	FC0-4169-000		1	COVER, RIGHT, UPPER		
11	FC9-8944-000		1	ELIMINATOR, STATIC CHARGE		
12	FC9-2166-000		2	SHEET, ELES. PREVENTION		
13	FC9-8934-000		1	LABEL, HIGH TMP. CAUTION		
14	FC9-8943-000		1	LABEL, HIGH TMP. CAUTION		
15	FC0-3196-000		1	LABEL, USB		
16	FU7-8091-000		1	LABEL,GROUNDING CAUTION	JP	
17	HB1-5537-000		2	SHEET,BLANKING		
18	FC9-4897-000		1	LABEL, SIZE EXCHANGE		
19	XA9-1671-000		AR	SCREW, D, M3X8		
20	FC0-6761-000		1	LABEL, SIZE, MANUAL FEED	JP	
20	FC9-7005-000		1	LABEL, SIZE, MANUAL FEED	EXCEPT JP	
21	FM3-9791-000		1	REAR COVER ASSEMBLY		
22	FM4-9829-000		1	EXPANSION TRAY ASSEMBLY	JP	
22	FM3-9793-000		1	EXPANSION TRAY ASSEMBLY	EXCEPT JP	
23	FM4-9783-000		1	INNER COVER ASSEMBLY		
24	FC9-2016-000		1	COVER, FRONT, LOWER		
25	FM4-9772-000		1	CONTROL PANEL ASSEMBLY	MF6780dw	
25	FM4-9773-000		1	CONTROL PANEL ASSEMBLY	D1380	
25	FM4-9770-000		1	CONTROL PANEL ASSEMBLY	D1370	

FIGURE & KEY NO.	PARTS NUMBER	RANK	Q'TY	DESCRIPTION	SERIAL NUMBER/REMARKS	SVC
25	FM4-9774-000		1	CONTROL PANEL ASSEMBLY	D1350 TW	
25	FM4-9771-000		1	CONTROL PANEL ASSEMBLY	D1350 US,CA,LTN	
25	FM4-9775-000		1	CONTROL PANEL ASSEMBLY	D1320	
26	FM3-9816-000		1	HINGE ASSEMBLY		
27	FC0-4144-000		1	COVER, ONE-TOUCH	FAX model D1380	
27	FC0-4141-000		1	COVER, ONE-TOUCH	FAX model D1370	
27	FC0-4145-000		1	COVER, ONE-TOUCH	FAX model D1350 TW	
27	FC0-4142-000		1	COVER, ONE-TOUCH	FAX model D1350 US,CA,LTN	
27	FC0-4143-000		1	COVER, ONE-TOUCH	FAX model MF6780dw	
27	FC0-3108-000		1	COVER, ONE-TOUCH	EXCEPT FAX model	
28	RC2-6273-000		1	HINGE, MULTI-PURPOSE, RIGHT		
29	RC2-8291-000		1	HINGE, MULTI-PURPOSE, LEFT		
30	RM1-6427-000		1	MP LIFTING PLATE ASSEMBLY		
31	RU5-2895-000		2	SPRING, TENSION		
32	RM1-6441-000		1	DUPLEXING PAPER FEED ASS'Y		

FIGURE 101 INTERNAL COMPONENTS 1

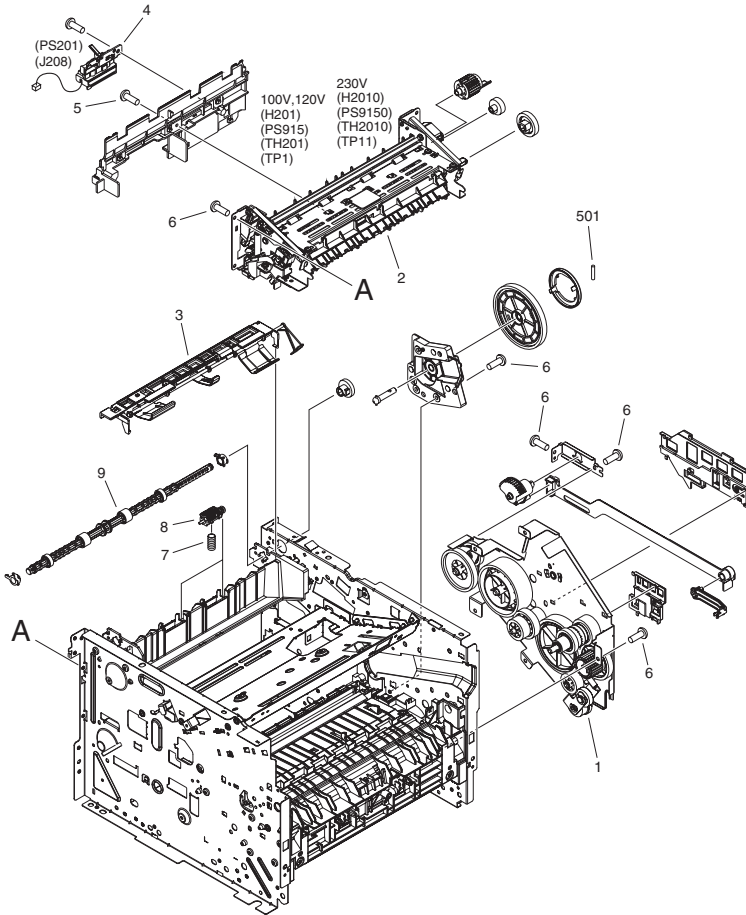

FIGURE & KEY NO.	PARTS NUMBER	R A N K	Q'TY	DESCRIPTION	SERIAL NUMBER/ REMARKS	S V C
Fig.101	NPN		RF	INTERNAL COMPONENTS 1		
1	RM1-6421-000		1	MAIN DRIVE ASS'Y	MF5900 Series	
1	FM3-9797-000		1	MAIN DRIVE ASSEMBLY	EXCEPT MF5900 Series	
2	FM3-9088-000		1	FIXING ASS'Y	100V H201,PS915,TH201,TP1	
2	RM1-6405-000		1	FIXING ASS'Y	120V H201,PS915,TH201,TP1	
2	RM1-6406-000		1	FIXING ASS'Y	230V H2010,PS9150,TH2010,T P11	
3	RM1-6401-000		1	PAPER RETAINING DELIVERY ASS'Y		
4	RM1-6445-000		1	REVERSE SENSOR ASS'Y	PS201	
5	XA9-1503-000		AR	SCREW, TAP, M3X6		
6	XA9-1671-000		AR	SCREW, D, M3X8		
7	RU6-2610-000		2	SPRING, COMPRESSION		
8	RL1-2111-000		2	FACE-DOWN ROLLER UNIT		
9	RL1-2112-000		1	ROLLER, FACE-DOWN		
501	XD3-2300-322		1	PIN		

FIGURE & KEY NO.	PARTS NUMBER	RANK	Q'TY	DESCRIPTION	SERIAL NUMBER/REMARKS	SVC
Fig.102	NPN		RF	INTERNAL COMPONENTS 2		
1	RC2-6130-000		2	ROLLER, CASSETTE PAPER PICK-UP		
2	XA9-0994-000		1	SCREW, TP, M4X6		
3	RU5-2898-000		1	SPRING, TENSION		
4	RL1-2115-000		1	PAD, MULTI-PURPOSE SEPARATION		
5	RM1-1301-000		1	PAPER PICK-UP GEAR ASS'Y		
6	RM1-6350-000		1	MULTI-PURPOSE SENSOR PCB ASS'Y	PS202	
7	RM1-6378-000		1	MAIN MOTOR ASS'Y	M201	
8	RM1-6414-000		1	PAPER PICK-UP ROLLER ASS'Y		
9	XA9-1671-000		AR	SCREW, D, M3X8		
10	FM4-9787-000		1	MAIN SWITCH UNIT	MF6780dw SW10	
10	FM4-5367-000		1	MAIN SWITCH UNIT	EXCEPT MF6780dw SW1	
11	FM4-9055-000		1	INLET CABLE ASSEMBLY	MF6780dw P10	
11	FM4-5386-000		1	INLET CABLE ASSEMBLY	EXCEPT MF6780dw P1	
501	XD1-3100-407		1	LOCK-WASHER, SPRING		

FIGURE 103 INTERNAL COMPONENTS 3

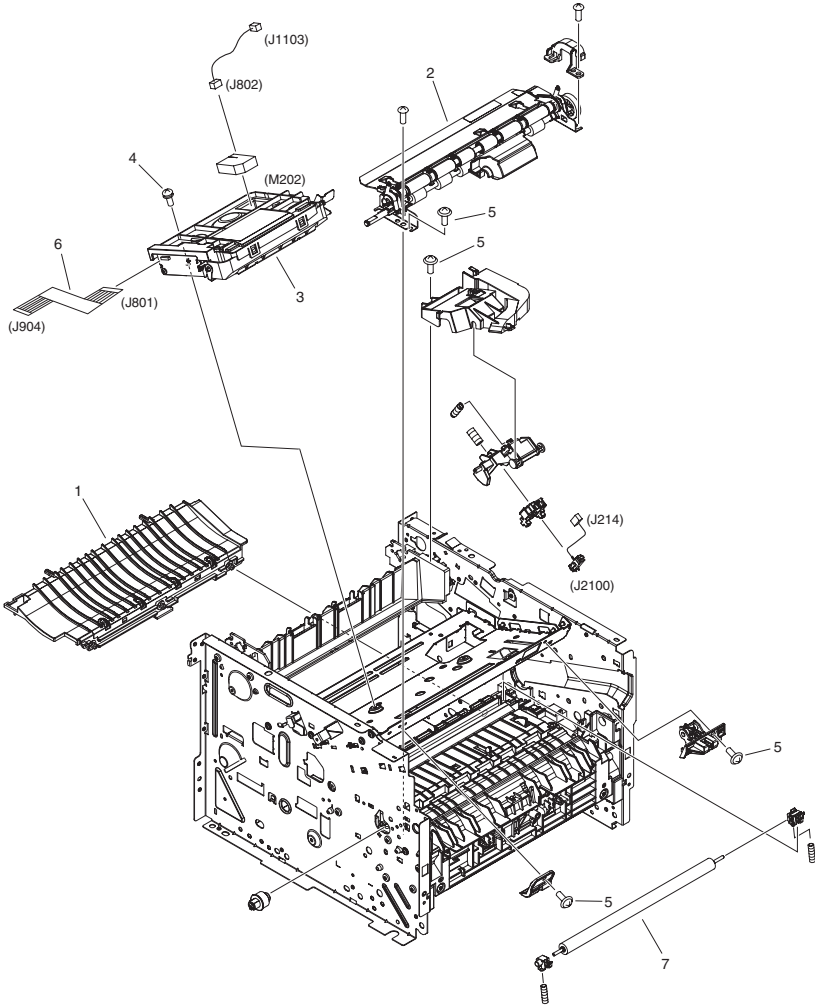
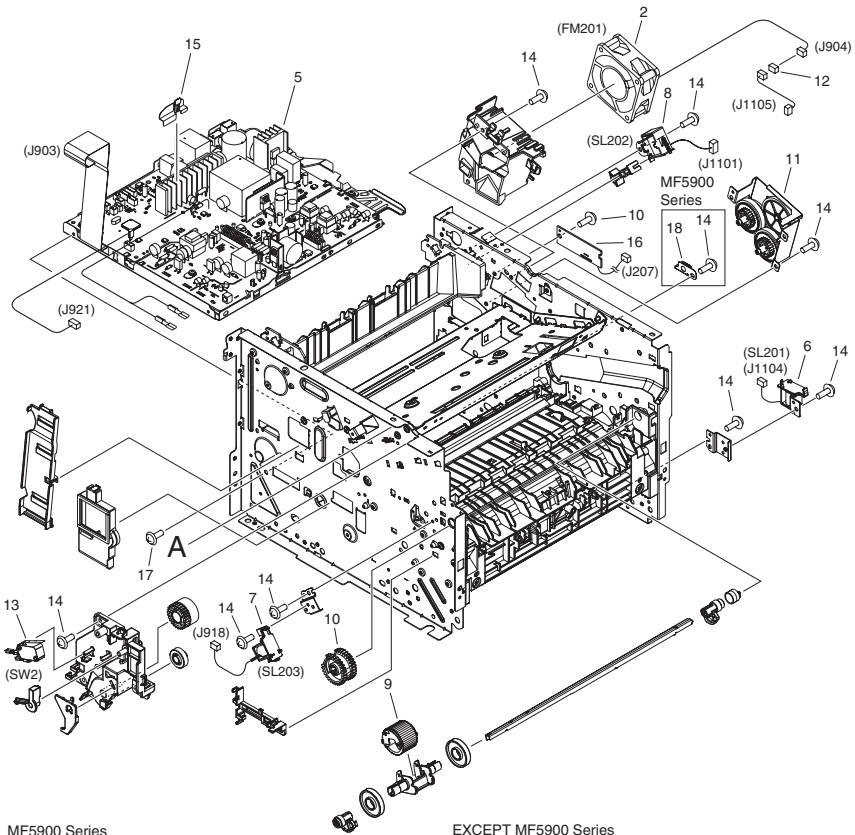
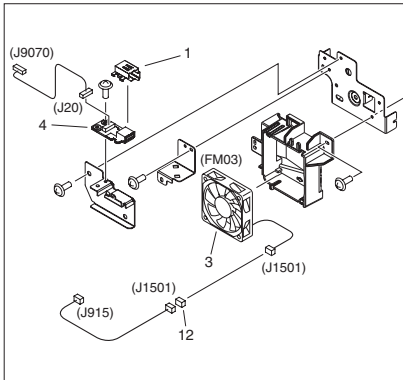

FIGURE & KEY NO.	PARTS NUMBER	RANK	Q'TY	DESCRIPTION	SERIAL NUMBER/REMARKS	SVC
Fig.103	NPN		RF	INTERNAL COMPONENTS 3		
1	RM1-6402-000		1	PAPER FEED GUIDE ASS'Y		
2	RM1-6419-000		1	REGISTRATION ASS'Y		
3	RM1-6424-000		1	SCANNER ASS'Y	M202	
4	XA9-1420-000		AR	SCREW, WWASHER, M3X8		
5	XA9-1671-000		AR	SCREW, D, M3X8		
6	FK3-0730-000		1	CABLE, FLAT		
7	RM1-6450-000		1	TRANSFER ROLLER ASS'Y		

FIGURE 104 INTERNAL COMPONENTS 4



MF5900 Series



EXCEPT MF5900 Series

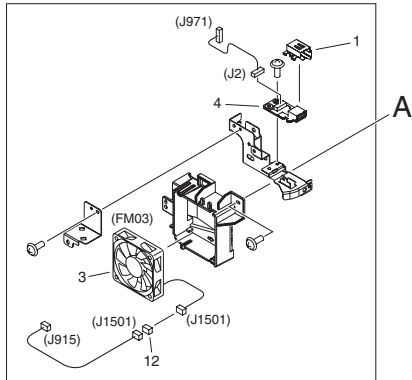

FIGURE & KEY NO.	PARTS NUMBER	RANK	Q'TY	DESCRIPTION	SERIAL NUMBER/REMARKS	SVC
Fig.104	NPN		RF	INTERNAL COMPONENTS 4		
1	FC9-2142-000		1	PLATE, USB GROUNDING		
2	FK2-2064-000		1	FAN	FM201	
3	FK3-0732-000		1	FAN	FM03	
4	FM4-3989-000		1	USB PCB ASSEMBLY		
5	FM4-9009-000		1	ENGINE CONTROLLER PCB ASS'Y	120V MF5900 Series	
5	FM4-9011-000		1	ENGINE CONTROLLER PCB ASS'Y	100V,120V EXCEPT MF5900 Series	
5	FM4-9010-000		1	ENGINE CONTROLLER PCB ASS'Y	230V MF5900 Series	
5	FM4-9012-000		1	ENGINE CONTROLLER PCB ASS'Y	230V EXCEPT MF5900 Series	
6	RK2-2729-000		1	SOLENOID	SL201	
7	RK2-2731-000		1	SOLENOID	SL203	
8	RK2-2733-000		1	SOLENOID	SL202	
9	RL1-2120-000		1	ROLLER,MULTI-PURPOSE PICK-UP		
10	RM1-4275-000		1	PAPER PICK-UP GEAR ASS'Y		
11	RM1-6423-000		1	REVERSE DRIVE ASS'Y		
12	VS1-7177-003		1	CONNECTOR, SNAP TIGHT, BK		
13	WC4-5171-000		1	MICROSWITCH	SW2	
14	XA9-1671-000		AR	SCREW, D, M3X8		
15	FC9-8942-000		1	SHEET, PROTECTIVE		
16	FM4-1605-000		1	CONNECTING PCB ASS'Y		
17	XA9-1503-000		AR	SCREW, TAP, M3X6		
18	RC2-1568-000		1	PLATE, GROUNDING	MF5900 Series	

FIGURE & KEY NO.	PARTS NUMBER	RANK	Q'TY	DESCRIPTION	SERIAL NUMBER/REMARKS	SVC
Fig.105	NPN		RF	INTERNAL COMPONENTS 5		
1	FC0-3182-000		1	SHEET, CABLE PROTECTION	FAX model	
2	XA9-1671-000		AR	SCREW, D, M3X8		
3	FK3-1826-000		1	SPEAKER	FAX model SP202	
4	FK3-1626-000		1	BATTERY, NI-MH	FAX model	
5	FM4-8967-000		1	P-CI PCB ASSEMBLY	FAX model MF6780dw	
5	FM4-8968-000		1	OFFHOOK PCB ASSEMBLY	FAX model EXCEPT MF6780dw	
6	FM4-9214-000		1	MAIN CONTROLLER PCB ASSEMBLY	MF6780dw	
6	FM4-9211-000		1	MAIN CONTROLLER PCB ASSEMBLY	MF5980dw	
6	FM4-9209-000		1	MAIN CONTROLLER PCB ASSEMBLY	MF5960dn	
6	FM4-9210-000		1	MAIN CONTROLLER PCB ASSEMBLY	MF5950dw	
6	FM4-9208-000		1	MAIN CONTROLLER PCB ASSEMBLY	MF5940dn	
6	FM4-9212-000		1	MAIN CONTROLLER PCB ASSEMBLY	D1380	
6	FM4-9213-000		1	MAIN CONTROLLER PCB ASSEMBLY	D1370	
6	FM4-8947-000		1	MAIN CONTROLLER PCB ASSEMBLY	D1350	
6	FM4-8946-000		1	MAIN CONTROLLER PCB ASSEMBLY	D1320	
7	FM4-8963-000		1	NCU PCB ASSEMBLY	FAX model JP	
7	FM4-8965-000		1	NCU PCB ASSEMBLY	FAX model EUR	
7	FM4-8964-000		1	NCU PCB ASSEMBLY	FAX model EXCEPT JP,EUR	
8	FK3-1820-000		1	CABLE, FLAT	FAX model	
9	FM4-9008-000		1	ARRESTOR PCB ASSEMBLY	MF6780dw	
10	FK3-1821-000		1	CABLE, FLAT	WIRELESS model	
11	FM4-9831-000		1	WIRELESS LAN PCB ASSEMBLY	WIRELESS model	

FIGURE 106
INTERNAL COMPONENTS 6 (MF5900 Series)

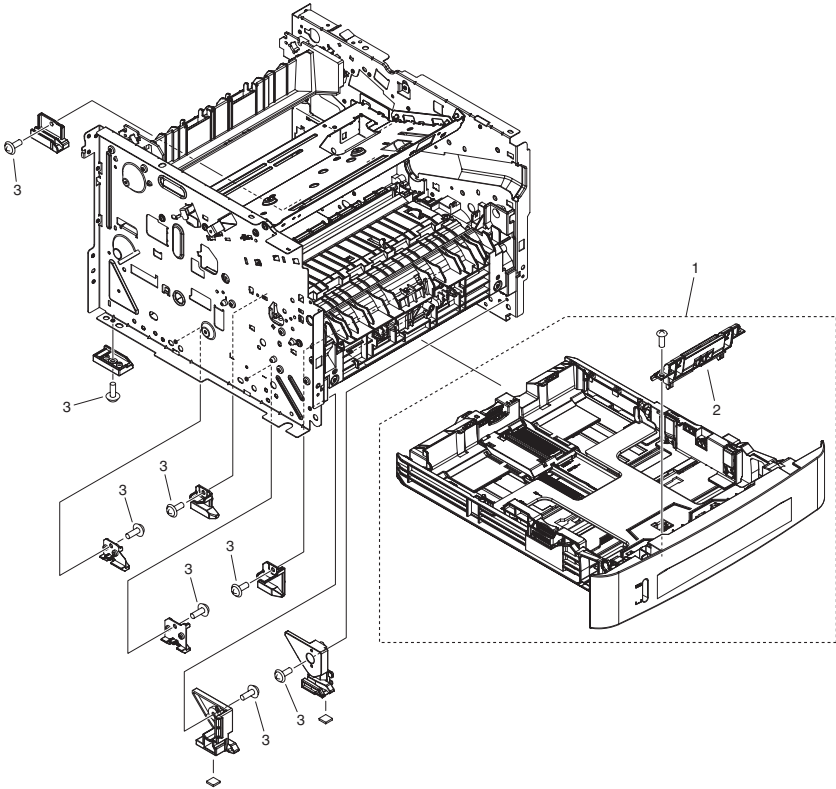

FIGURE & KEY NO.	PARTS NUMBER	RANK	Q'TY	DESCRIPTION	SERIAL NUMBER/REMARKS	SVC
Fig.106	NPN		RF	INTERNAL COMPONENTS 6	MF5900 Series	
1	FM3-8839-000		1	CASSETTE ASS'Y		
2	RM1-6397-000		1	SEPARATION PAD HOLDER ASS'Y		
3	XA9-1671-000		AR	SCREW, D, M3X8		

FIGURE 106A
INTERNAL COMPONENTS 6 (EXCEPT MF5900 Series)

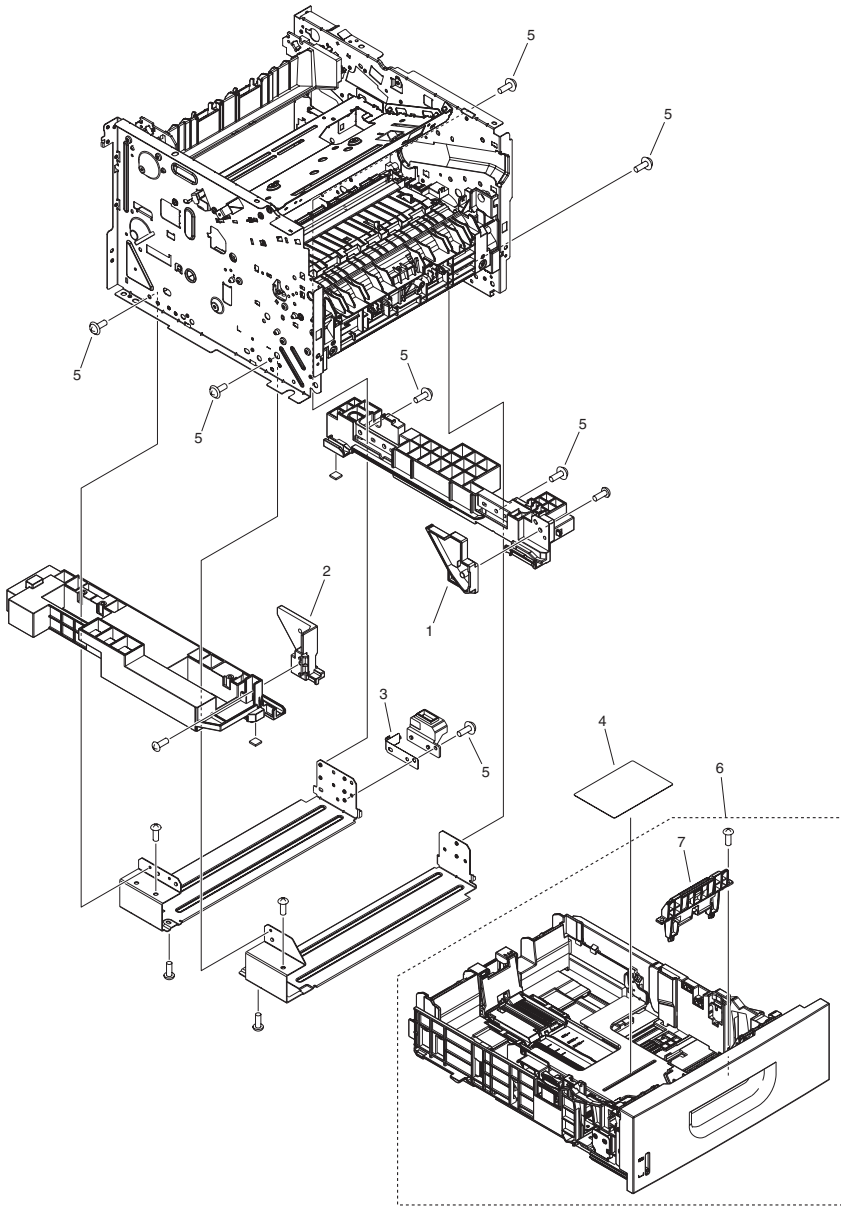

FIGURE & KEY NO.	PARTS NUMBER	RANK	Q'TY	DESCRIPTION	SERIAL NUMBER/REMARKS	SVC
Fig.106A	NPN		RF	INTERNAL COMPONENTS 6	EXCEPT MF5900 Series	
1	FC9-2068-000		1	GUIDE, CASSETTE, RIGHT		
2	FC9-2069-000		1	GUIDE, CASSETTE, LEFT		
3	FC9-2071-000		1	SPRING, LEAF		
4	FC9-4891-000		1	LABEL, EXCHANGE CONTROL PANEL		
5	XA9-1671-000		AR	SCREW, D, M3X8		
6	FM3-9798-000		1	CASSETTE ASSEMBLY		
7	RM1-6454-000		1	SEPARATION PAD ASS'Y		

FIGURE 160 READER/ADF ASSEMBLY (MF5900 Series)

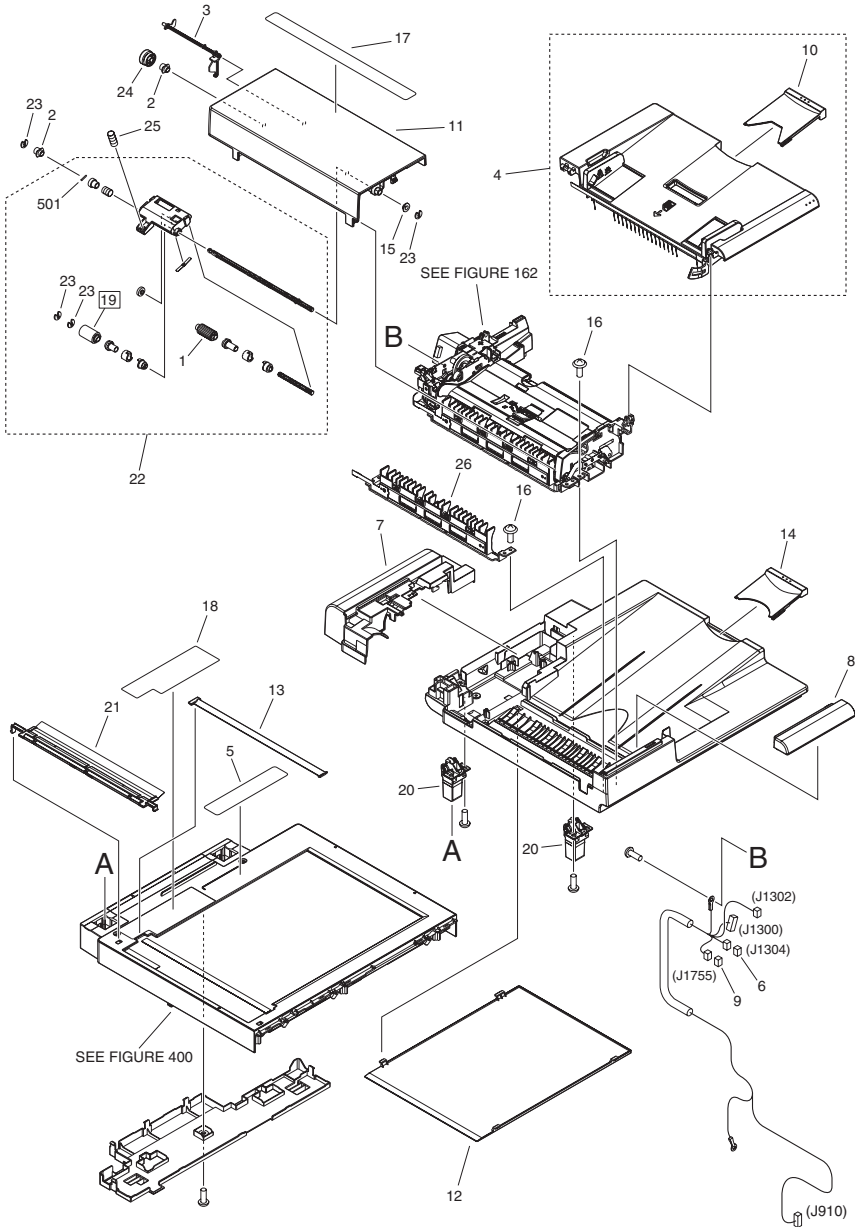

FIGURE & KEY NO.	PARTS NUMBER	R A N K	Q'TY	DESCRIPTION	SERIAL NUMBER/ REMARKS	S V C
Fig.160	NPN		RF	READER/ADF ASSEMBLY	MF5900 Series	
1	FC7-6189-000		1	ROLLER, PICK-UP		
2	FC7-6320-000		2	BUSHING		
3	FC7-6321-000		1	FLAG, DOCUMENT SCANNER		
4	FM4-1876-000		1	DOCUMENT TRAY ASSEMBLY		
5	FC9-1494-000		1	LABEL, COPY PROHIBITION	US,CA,LTN,EUR	
5	FC9-5111-000		1	LABEL, COPY PROHIBITION	LTN,SG,AU,CN,KR	
6	VS1-7177-002		1	CONNECTOR, SNAP TIGHT, BK		
7	FC9-1532-000		1	COVER, REAR		
8	FC9-1533-000		1	COVER, FRONT UPPER		
9	VS1-7207-004		1	CONNECTOR, SNAP TIGHT, BK		
10	FC9-1535-000		1	TRAY, SUB DOCUMENT		
11	FC9-1536-000		1	PANEL, OPEN/CLOSE		
12	FC9-1539-000		1	SHEET, WHITE		
13	FC9-5109-000		1	PLATE, PAPER SIZE	A SIZE	
13	FC9-7575-000		1	PLATE, PAPER SIZE	INCH/A SIZE	
13	FC9-7576-000		1	PLATE, PAPER SIZE	INCH/AB SIZE	
14	FC9-5655-000		1	TRAY, SUB		
15	HU1-1022-000		1	BUSHING		
16	XA9-0831-000		7	SCREW,M3X10		
17	FC9-7563-000		1	LABEL, SIZE INDEX	A SIZE	
17	FC9-7562-000		1	LABEL, SIZE INDEX	INCH/A SIZE	
17	FC9-7564-000		1	LABEL, SIZE INDEX	INCH/AB SIZE	
18	FC9-7567-000		1	LABEL, GLASS CLEANING	A SIZE	
18	FC9-7566-000		1	LABEL, GLASS CLEANING	INCH/A SIZE	
18	FC9-7568-000		1	LABEL, GLASS CLEANING	INCH/AB SIZE	
19	FL2-6637-000		1	ROLLER, SEPARATION	[DP]	
20	FL3-2453-000		2	HINGE, ADF		
21	FL3-3539-000		1	HOLDER, DOCUMENT,RELEASE SHEET		
22	FM3-9538-000		1	SEPARATION ROLLER ASSEMBLY		
23	HC1-0586-000		4	RETAINING RING		
24	FU7-0672-000		1	GEAR, 24T		

FIGURE & KEY NO.	PARTS NUMBER	R A N K	Q'TY	DESCRIPTION	SERIAL NUMBER/ REMARKS	S V C
25	FU7-2018-000		1	SPRING, COMPRESSION		
26	FM4-1883-000		1	PAPER FEED GUIDE ASSEMBLY		
501	XD9-0219-000		1	PIN, DOWEL		

FIGURE 160A READER/ADF ASSEMBLY (EXCEPT MF5900 Series)

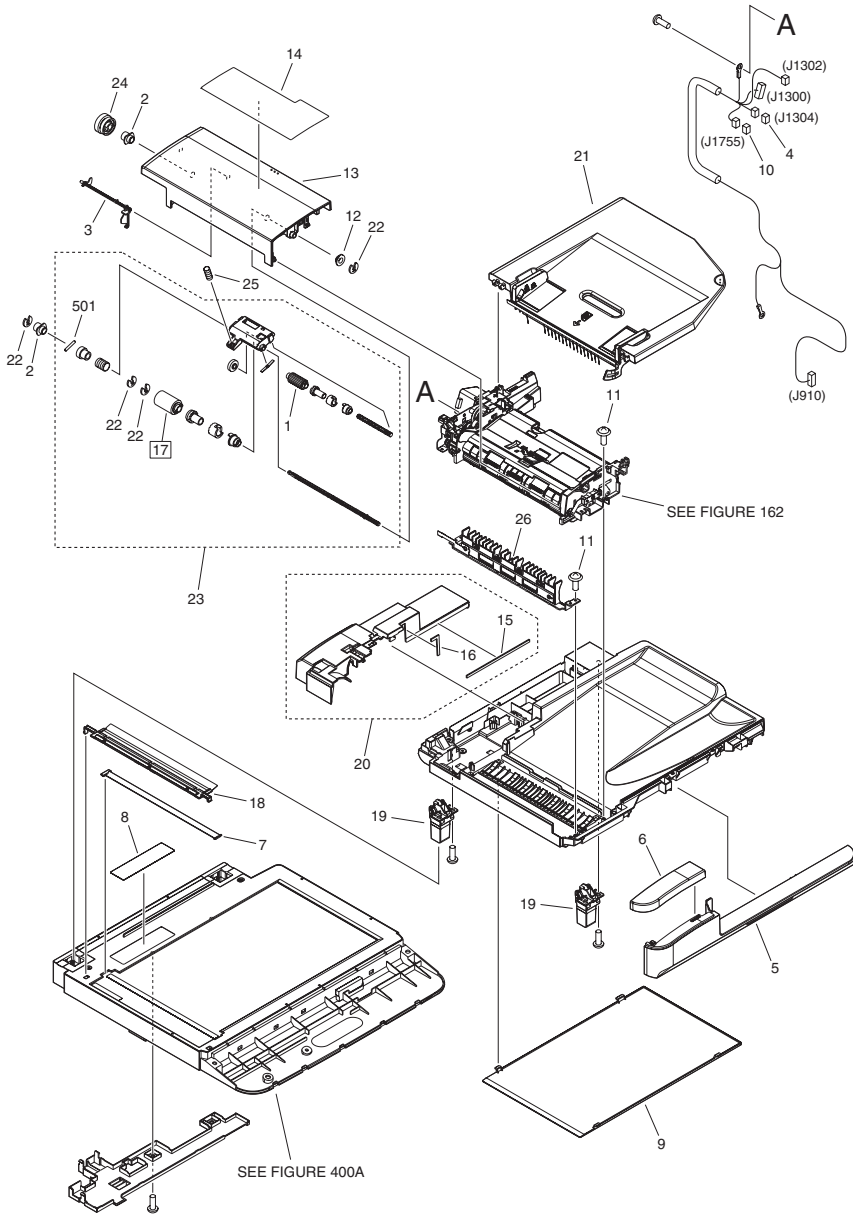

FIGURE & KEY NO.	PARTS NUMBER	R A N K	Q'TY	DESCRIPTION	SERIAL NUMBER/ REMARKS	S V C
Fig.160A	NPN		RF	READER/ADF ASSEMBLY		
1	FC7-6189-000		1	ROLLER, PICK-UP		
2	FC7-6320-000		2	BUSHING		
3	FC7-6321-000		1	FLAG, DOCUMENT SCANNER		
4	VS1-7177-002		1	CONNECTOR, SNAP TIGHT, BK		
5	FC9-1496-000		1	COVER, ADF, FRONT LOWER		
6	FC9-4998-000		1	COVER, ADF, FRONT UPPER		
7	FC9-1486-000		1	PLATE, PAPER SIZE	INCH/A SIZE	
7	FC9-5110-000		1	PLATE, PAPER SIZE	INCH/AB SIZE	
7	FC9-5115-000		1	PLATE, PAPER SIZE	A/B SIZE	
8	FC9-1494-000		1	LABEL, COPY PROHIBITION	US,CA,LTN	
8	FC9-5111-000		1	LABEL, COPY PROHIBITION	JP,TW,CN	
9	FC9-1499-000		1	SHEET, WHITE		
10	VS1-7207-004		1	CONNECTOR, SNAP TIGHT, BK		
11	XA9-0831-000		7	SCREW,M3X10		
12	HU1-1022-000		1	BUSHING		
13	FC9-4999-000		1	PANEL, OPEN/CLOSE		
14	FU7-8987-000		1	LABEL, GLASS CLEANING	INCH/A SIZE	
14	FU7-8988-000		1	LABEL, GLASS CLEANING	INCH/AB SIZE	
14	FU7-8986-000		1	LABEL, GLASS CLEANING	A/B SIZE MF6780dw	
15	FC9-5660-000		1	CUSHION		
16	FC9-5661-000		1	CUSHION		
17	FL2-6637-000		1	ROLLER, SEPARATION	[DP]	
18	FL3-3539-000		1	HOLDER, DOCUMENT,RELEASE SHEET		
19	FL3-1430-000		2	HINGE, ADF		
20	FL3-1439-000		1	ADF REAR COVER ASSY		
21	FM4-1888-000		1	DOCUMENT TRAY ASSEMBLY		
22	HC1-0586-000		4	RETAINING RING		
23	FM3-9538-000		1	SEPARATION ROLLER ASSEMBLY		
24	FU7-0672-000		1	GEAR, 24T		
25	FU7-2018-000		1	SPRING, COMPRESSION		
26	FM4-1883-000		1	PAPER FEED GUIDE ASSEMBLY		

FIGURE & KEY NO.	PARTS NUMBER	R A N K	Q'TY	DESCRIPTION	SERIAL NUMBER/ REMARKS	S V C
501	XD9-0219-000		1	PIN, DOWEL		

FIGURE 162 PAPER FEEDER ASSEMBLY

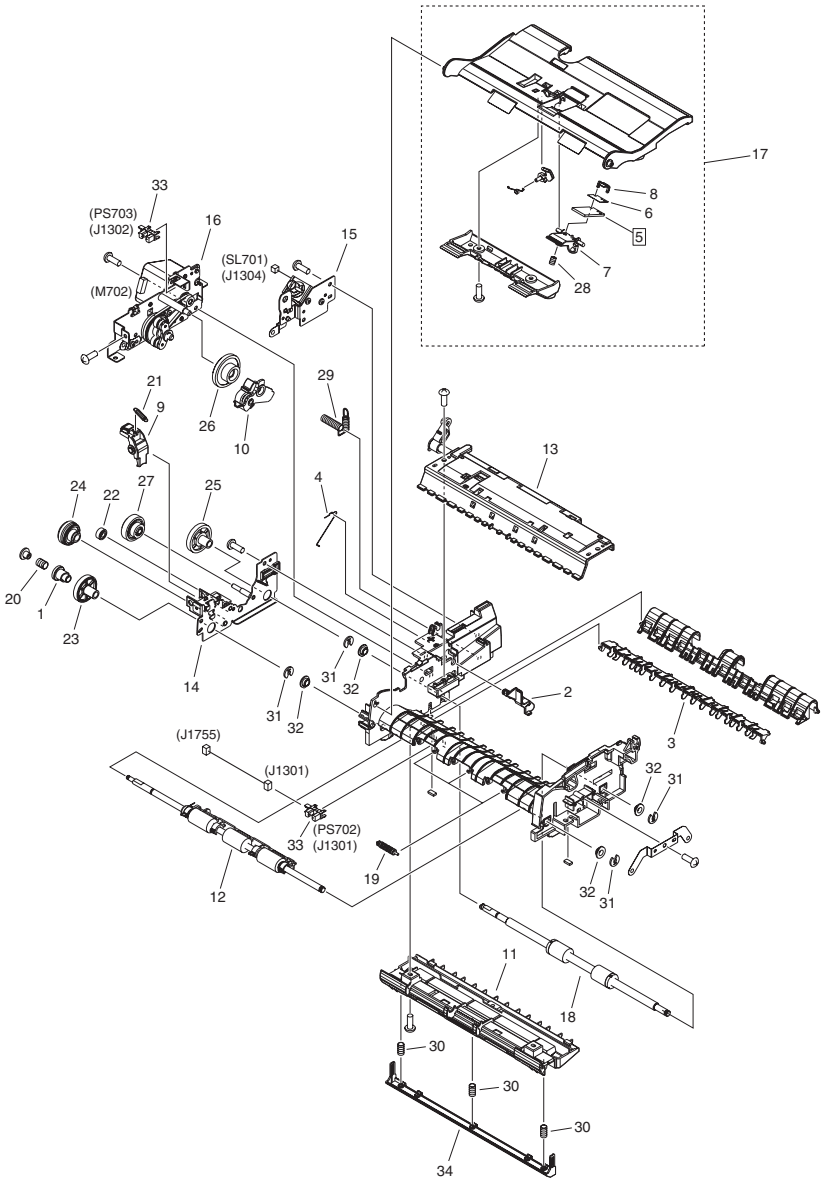

FIGURE & KEY NO.	PARTS NUMBER	R A N K	Q'TY	DESCRIPTION	SERIAL NUMBER/ REMARKS	S V C
Fig.162	NPN		RF	PAPER FEEDER ASSEMBLY		
1	FC7-6052-010		1	RATCHET, PAPER FEED ROLLER		
2	FC7-6182-000		1	LEVER, ROLLER RELEASE		
3	FC7-6278-000		1	FLAPPER, PAPER DELIVERY		
4	FC7-6281-000		1	SPRING, ARM		
5	FC7-6297-000		1	PAD, SEPARATION	[DP]	
6	FC9-5654-000		1	SHEET, SEPARATION PAD		
7	FC7-6299-000		1	HOLDER, SEPARATION PAD		
8	FC7-6300-000		1	CLAMP, SEPARATION PAD		
9	FC9-1512-000		1	LEVER, RELEASE		
10	FL3-1431-000		1	ARM, SEPARATION SWING		
11	FL3-1437-000		1	GUIDE LOWER ASSEMBLY		
12	FM4-1885-000		1	PAPER FEED ROLLER ASSEMBLY		
13	FM3-9541-000		1	PAPER DELIVERY ASSEMBLY		
14	FM3-9542-000		1	DRIVE PLATE ASSEMBLY		
15	FM3-9543-000		1	SOLENOID ASSEMBLY	SL701	
16	FM4-8853-000		1	MOTOR DRIVE ASSEMBLY	M702	
17	FM4-1873-000		1	GUIDE ASSEMBLY, UPPER		
18	FL3-2458-000		1	PAPER DELIVERY ROLLER ASS'Y		
19	FU5-6992-000		3	ROLLER, AUXILIARY		
20	FU6-2998-000		1	SPRING, COMPRESSION		
21	FU6-2999-000		1	SPRING, TENSION		
22	FU7-0667-000		1	GEAR, 20T		
23	FU7-0668-000		1	GEAR, 54T		
24	FU7-0669-000		1	GEAR, 46T/23T		
25	FU7-0671-000		1	GEAR, 36T		
26	FU7-0676-000		1	GEAR, 21T/42T		
27	FU7-0678-000		1	GEAR, 51T/17T		
28	FU7-2016-000		1	SPRING, COMPRESSION		
29	FU7-2021-000		1	SPRING, COMPRESSION		
30	FU8-2008-000		3	SPRING, COMPRESSION		
31	HC1-0586-000		5	RETAINING RING		

FIGURE & KEY NO.	PARTS NUMBER	R A N K	Q'TY	DESCRIPTION	SERIAL NUMBER/ REMARKS	S V C
32	HU1-1022-000		4	BUSHING		
33	WG8-5696-000		2	PHOTO INTERRUPTER, TLP1243	PS702,PS703	
34	FC9-1537-000		1	PLATE, SEPARATION GUIDE		

FIGURE 400 READER ASSEMBLY (MF5900 Series)

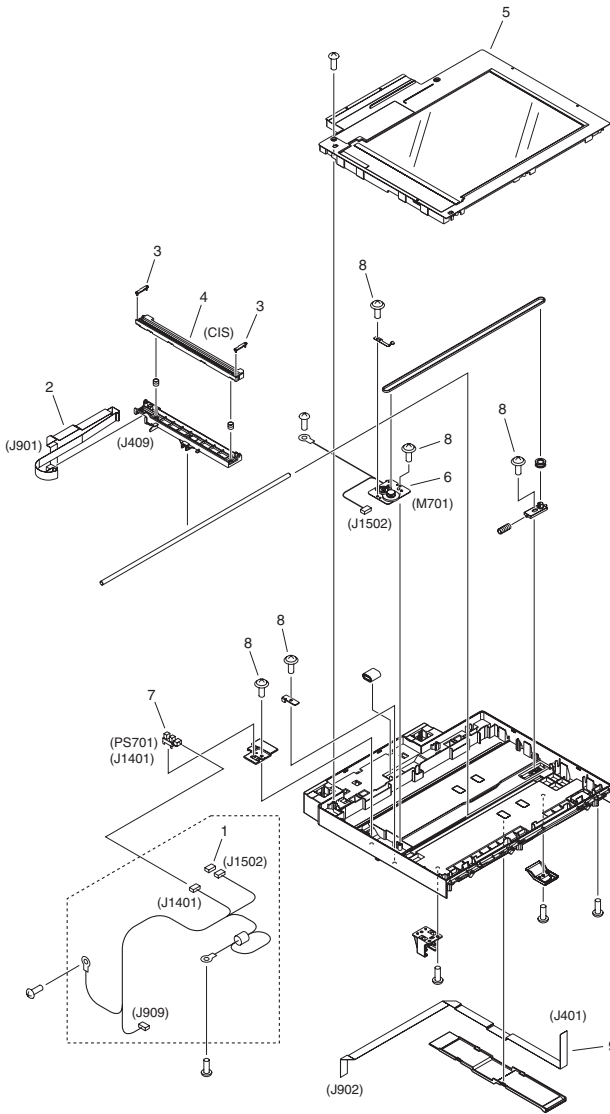

FIGURE & KEY NO.	PARTS NUMBER	RANK	Q'TY	DESCRIPTION	SERIAL NUMBER/REMARKS	SVC
Fig.400	FM4-6601-000		1	READER ASSEMBLY	MF5900 Series	
1	VS1-7177-004		1	CONNECTOR, SNAP TIGHT, BK		
2	FL3-5850-000		1	CABLE, FLAT		
3	FC9-7574-000		2	SPACER, CIS		
4	FK3-1904-000		1	CONTACT IMAGE SENSOR	CIS	
5	FM4-4308-000		1	READER COVER UNIT		
6	FM4-9070-000		1	DC MOTOR ASSEMBLY	M701	
7	WG8-5696-000		1	PHOTO INTERRUPTER, TLP1243	PS701	
8	XA9-0476-000		AR	SCREW,TP M3X8		
9	FK3-1907-000		1	CABLE, FLAT		

FIGURE 400A READER ASSEMBLY (EXCEPT MF5900 Series)

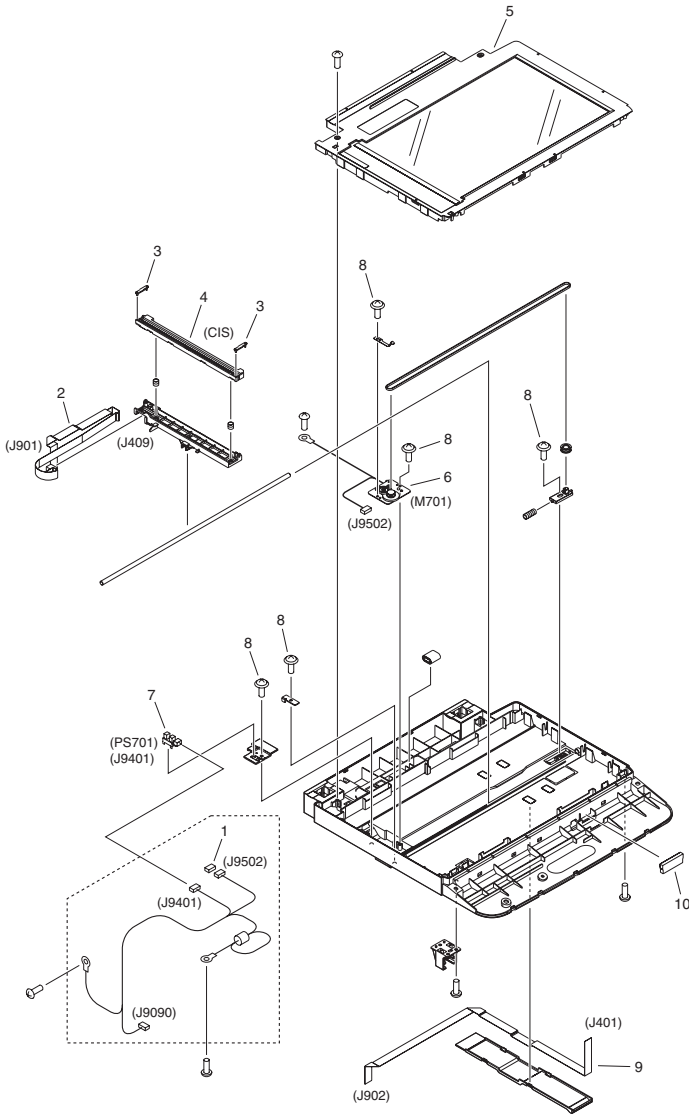

FIGURE & KEY NO.	PARTS NUMBER	RANK	Q'TY	DESCRIPTION	SERIAL NUMBER/REMARKS	SVC
Fig.400A	FM4-8841-000		1	READER ASSEMBLY	EXCEPT MF5900 Series	
1	VS1-7177-004		1	CONNECTOR, SNAP TIGHT, BK		
2	FL3-5849-000		1	CABLE, FLAT		
3	FC9-7574-000		2	SPACER, CIS		
4	FK3-1904-000		1	CONTACT IMAGE SENSOR	CIS	
5	FM4-9072-000		1	READER COVER UNIT		
6	FM4-9071-000		1	DC MOTOR ASSEMBLY	M701	
7	WG8-5696-000		1	PHOTO INTERRUPTER, TLP1243	PS701	
8	XA9-0476-000		AR	SCREW,TP M3X8		
9	FK3-1908-000		1	CABLE, FLAT		
10	FC0-4177-000		1	SHEET, CABLE PROTECTION		

FIGURE ZZA

MECHANICAL STANDARD PARTS (HOW TO USE)

Mechanical standard parts

機械標準部品

About a mechanical standard parts

A Mechanical standard parts is a mechanical part which not parts peculiar to a product. They are parts which are common to a Canon product and are used, such as a screw and a washer. The Fig No. and parts number of the mechanical standard parts are not listed in the product parts catalog. Refer to the parts catalog of mechanical standard parts when checking the parts number for screw or washer etc. and identify them by part shape or size.

機械標準部品とは

機械標準部品とは、製品特有の部品ではなく、ねじやワッシャなどキヤノン製品共通で使用されている機械部品（メカ部品）のことです。
製品のパーツカタログには、機械標準部品のFig No.や部品番号は記載しておりません。
ねじや、ワッシャ等の部品番号を調べるときは、機械標準部品のパーツカタログを参照し、部品の形状や大きさから判断し、使用している部品を調べてください。

Material and surface treatment of a mechanical standard parts

Material and surface treatment of mechanical standard parts are assigned commonly for each part. Refer to the Table 1 for the parts which material and surface treatment are assigned as numbers.

機械標準部品の材料および表面処理

機械標準部品の材料および表面処理については、各種部品共通で決められています。
材料および表面処理が番号で決められている部品については、表1を参照してください。

Table 1 Material and Surface treatment
表1 材料および表面処理

No. 番号	Material 材料	Surface treatment 表面処理	Color 色
1	Stainless steel ステンレス	Stainless steel black coloring (BC4) ステンレス黒着色(BC4)	Black 黒
2		not to be given なし	White 白
3	Brass 黄銅	Regular nickel plating (NL) 普通ニッケルメッキ(NL)	White 白
4		Black nickel plating (BN) 黒色ニッケルメッキ(BN)	Black 黒
5	Steel 鋼	White zinc trivalent chromate treating (ZC3) 白色亜鉛3価クロメート(ZC3)	White 白
6		Regular nickel chromium plating (NC) 普通ニッケルクロムメッキ(NC)	White 白
7		Regular nickel plating (NL) 普通ニッケルメッキ(NL)	White 白
8		Iron and steel phosphating (P1) 鉄鋼磷酸塩処理(P1)	Black 黒
9		Black zinc trivalent chromate treating (BZ3) 黒色亜鉛3価クロメート(BZ3)	Black 黒

FIGURE ZZB MECHANICAL STANDARD PARTS (SCREWS)

1. Screws ねじ

How to read Parts Numbers
部品番号の見方

Screws
ねじ

XB1-2400-609

Type No.
類別番号
Normal designation (d)
ねじの呼び(d)
Length (L)
ねじの長さ(L)
Material and Surface treatment
材料および表面処理

XB1-2 expresses Binding head machine screw.
XB1-2は、バインドねじを表す
40 expresses M4.0.
40は、M4.0を表す
0-60 expresses a length of 6.0mm.
0-60は、6.0mmの長さを表す
9 expresses Steel (Black zinc trivalent chromate
treating) from Table 1.
9は、表1より鋼(黒色亜鉛3価クロメート)を表す

1-1. Cross Recessed Head Screws for Precision Equipments 精密機器用十字穴付き小ねじ

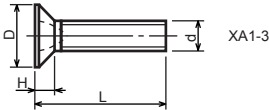
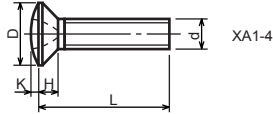
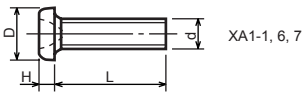

Type No. 類別番号	Type 類別	Head size (mm) 頭部寸法 (mm)							
		M1.4	M1.6	M1.7	M2	M2.5	M2.6		
XA1-1	Pan head Class 1 なべ1種	D	XA1-1	2	2.4	2.5	3	3.8	4
		H	XA1-1	0.5	0.55	0.5	0.6	0.9	0.8
XA1-3	Countersunk head Class 1 さら1種	D	XA1-3	2	2.4	2.5	3	3.8	4
		H	XA1-3	0.48	0.55	0.58	0.73	0.85	0.93
XA1-4	Oval countersunk head Class 1 丸さら1種	D	XA1-4	2	2.4	2.5	3	3.8	4
		H + K	XA1-4	0.68	0.8	0.88	1	1.25	1.3
XA1-6	Pan head Class 3 なべ3種	D	XA1-6	2.5	2.8	3	3.5	4.3	4.5
		H	XA1-6	0.8	0.85	0.9	1	1.3	1.2
XA1-7	Pan head Class 2 なべ2種	D	XA1-7	2.5	2.8	3	3.5	4.3	4.5
		H	XA1-7	0.5	0.55	0.5	0.6	0.9	0.8

1-2. Precision Tapping Screws
精密用タッピンねじ

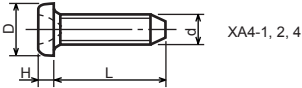

XA4-1, 2, 4

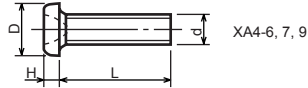

XA4-6, 7, 9

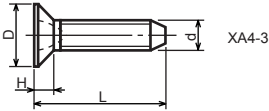

XA4-3

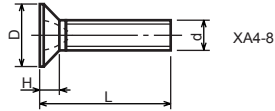

XA4-8

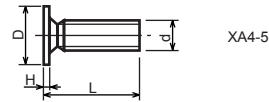

XA4-5

Type No. 類別番号	Type 類別	Head size (mm) 頭部寸法 (mm)						
		M1.4	M1.6	M1.7	M2	M2.5	M2.6	
XA4-1	With tapered end pan head Class 1 絞りなべ1種	D XA4-1	2	2.4	2.5	3	3.8	4
		H XA4-1	0.5	0.55	0.5	0.6	0.9	0.8
XA4-2	With tapered end pan head Class 3 絞りなべ3種	D XA4-2	2.5	2.8	3	3.5	4.3	4.5
		H XA4-2	0.8	0.85	0.9	1	1.3	1.2
XA4-3	With tapered end countersunk head 絞り-さら	D XA4-3	2	2.4	2.5	3	3.8	4
		H XA4-3	0.48	0.55	0.58	0.73	0.85	0.93
XA4-4	With tapered end pan head Class 2 絞りなべ2種	D XA4-4	2.5	2.8	3	3.5	4.3	4.5
		H XA4-4	0.5	0.55	0.5	0.6	0.9	0.8
XA4-5	With parallel end ultra thin head ストレート-超薄頭	D XA4-5	2.5	2.8	3	-	-	-
		H XA4-5	0.2	0.2	0.2	-	-	-
XA4-6	With parallel end pan head Class 1 ストレートなべ1種	D XA4-6	2	2.4	2.5	3	3.8	4
		H XA4-6	0.5	0.55	0.5	0.6	0.9	0.8
XA4-7	With parallel end pan head Class 3 ストレートなべ3種	D XA4-7	2.5	2.8	3	3.5	4.3	4.5
		H XA4-7	0.8	0.85	0.9	1	1.3	1.2
XA4-8	With parallel end countersunk head ストレート-さら	D XA4-8	2	2.4	2.5	3	3.8	4
		H XA4-8	0.48	0.55	0.58	0.73	0.85	0.93
XA4-9	With parallel end pan head Class 2 ストレートなべ2種	D XA4-9	2.5	2.8	3	3.5	4.3	4.5
		H XA4-9	0.5	0.55	0.5	0.6	0.9	0.8

1-3. Cross Recessed Head Screws
 一般用十字穴付き小ねじ

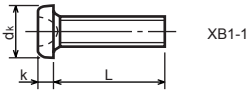

XB1-1

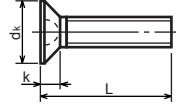

XB1-3

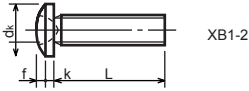

XB1-2

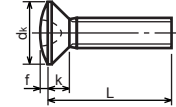

XB1-4

Type No. 類別番号	Type 類別
XB1-1	Pan head なべ
XB1-2	Binding head バインド
XB1-3	Countersunk head さら
XB1-4	Oval countersunk head 丸さら

		Head size (mm) 頭部寸法 (mm)					
		M2	M2.5	M2.6	M3	M4	M5
dk	XB1-1	3.5	4.5	4.5	5.5	7	9
k	XB1-1	1.3	1.7	1.7	2	2.6	3.3
dk	XB1-2	4.3	5.3	5.5	6.3	8.3	10.3
k+f	XB1-2	1.2	1.5	1.6	1.9	2.5	3.1
dk	XB1-3	4	5	-	6	8	10
k	XB1-3	1.2	1.45	-	1.75	2.3	2.8
dk	XB1-4	4	5	-	6	8	10
k+f	XB1-4	1.6	2	-	2.45	3.2	4
Screw part length ねじ部長さ b		8	12	12	12	16	20

1-4. Cross Recessed Head Screws with Captive Washer
 座金組み込み十字穴付き小ねじ

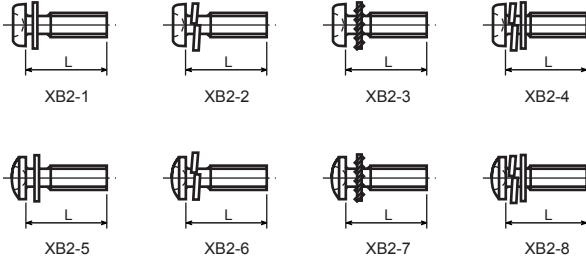

Type No. 類別番号	Type 類別
XB2-1	Pan head + Plain washer (circular bright) なべねじ+平座金
XB2-2	Pan head + Spring washer なべねじ+ばね座金
XB2-3	Pan head + Toothed lock washer なべねじ+歯付座金
XB2-4	Pan head + Spring washer and plain washer (circular bright) なべねじ+(ばね+平)座金
XB2-5	Binding head + Plain washer (circular bright) バインドねじ+平座金
XB2-6	Binding head + Spring washer バインドねじ+ばね座金
XB2-7	Binding head + Toothed lock washer バインドねじ+歯付座金
XB2-8	Binding head + Spring washer and plain washer (circular bright) バインドねじ+(ばね+平)座金

1-5. Hexagon Head Tapping Screws for Metallic Materials
 金属用六角タッピンねじ

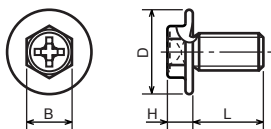

Type No. 類別番号	Type 類別	Head size (mm) 頭部寸法 (mm)	
		M3	M4
XB3-6	For metallic materials 金属用タッピン	D	8 10
		B	5.5 5.5
XB3-7	For metallic materials with clawed 金属用タッピン-つめ付き	H XB3-6	3.1 3.1
		H XB3-7	3.2 3.2

1-6. Special Tapping Screws
 特殊タッピンねじ

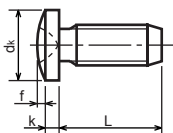

Type No. 類別番号	Type 類別	Head size (mm) 頭部寸法 (mm)	
		M3	M4
XB4-5	Binding head バインド	d _k	6.3 8.3
		k	1.3 1.7
		k+f	1.9 2.5

1-7. General Head Tapping Screws
一般用タッピンねじ

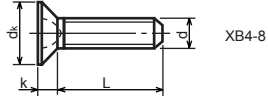
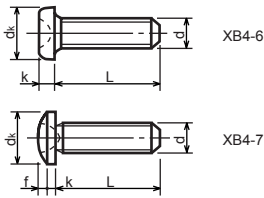

Type No. 類別番号	Type 類別	Head size (mm) 頭部寸法 (mm)						
		M2	M2.5	M2.6	M3	M4	M5	
XB4-6	Pan head なべ	d_k XB4-6	3.5	4.5	4.5	5.5	7	9
		k XB4-6	1.3	1.7	1.7	2	2.6	3.3
XB4-7	Binding head バインド	d_k XB4-7	4.3	5.3	5.5	6.3	8.3	10.3
		$k+f$ XB4-7	1.2	1.5	1.6	1.9	2.5	3.1
XB4-8	Countersunk head さら	d_k XB4-8	4	5	5.2	6	8	10
		k XB4-8	1.2	1.45	1.5	1.75	2.3	2.8

1-8. Tapping Screws for Metallic Materials
金属用タッピンねじ

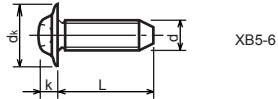
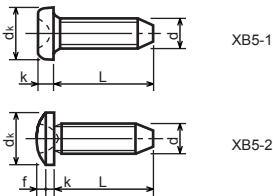

Type No. 類別番号	Type 類別	Head size (mm) 頭部寸法 (mm)					
		M2.5	M2.6	M3	M4	M5	
XB5-1	Pan head なべ	d_k XB5-1	4.5	4.5	5.5	7	9
		k XB5-1	1.7	1.7	2	2.6	3.3
XB5-2	Binding head バインド	d_k XB5-2	5.5	5.5	6.3	8.3	10.3
		$k+f$ XB5-2	1.6	1.6	1.9	2.5	3.1
XB5-6	Flanged pan head つば付きなべ	d_k XB5-6	6.5	6.5	8	10	12
		k XB5-6	2.1	2.1	1.75	3.2	4

1-9. Hexagon Socket Set Screws
六角穴付止めねじ

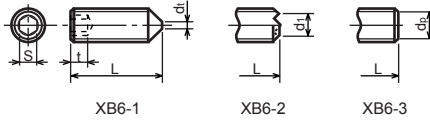

Type No. 類別番号	Type 類別	Head size (mm) 頭部寸法 (mm)							
		M1.6 M1.7	M2	M2.5 M2.6	M3	M5	M5	M6	
XB6-1	Cone point とがり先	S	0.7	0.9	1.3	1.5	2	2.5	3
		t	1.5	1.7	2	2	2.5	3	3.5
		$d_{t \max}$ XB6-1	0.4	0.5	0.65	0.75	1	1.25	1.5
		$d_{l \max}$ XB6-2	-	1.2	1.5	1.7	2.2	2.8	3.3
		$d_{l \min}$ XB6-2	-	1	1.2	1.4	1.9	2.4	2.9
XB6-3	Flat point 平先	$d_{p \max}$ XB6-3	0.8	1	1.5	2	2.5	3.5	4
		$d_{p \min}$ XB6-3	0.55	0.75	1.25	1.75	2.25	3.2	3.7

1-10. Flanged Pan Head Machine Screws
つば付きなべ小ねじ

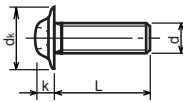

Type No. 類別番号	Type 類別	Head size (mm) 頭部寸法 (mm)					
		M2	M2.5 M2.6	M3	M5	M5	
XB6-7	Flanged pan head つば付きなべ	d_k	5	6.5	8	10	12
		k	1.7	2.1	2.5	3.2	4

FIGURE ZZC MECHANICAL STANDARD PARTS (BOLTS)

2. Bolts (Socket head cap screw) ボルト

How to read Parts Numbers
部品番号の見方

Bolt (Socket head cap screw)
ボルト

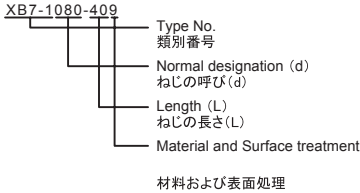

XB7-1 expresses Hexagon socket head cap screws.
XB7-1は、六角穴付きボルトを表す

080 expresses M8.0.
080は、M8.0を表す

40 expresses a length of 40mm.
40は、40mmの長さを表す

9 expresses Steel (Black zinc trivalent chromate
treating) from Table 1.

9は、表1より鋼(黒色亜鉛3価クロメート)を表す

2-1. Hexagon socket head cap screws 六角穴付きボルト

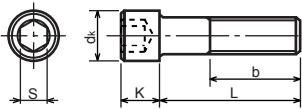

Type No. 類別番号	Type 類別
XB7-1	Hexagon socket head cap screws 六角穴付きボルト

	Head size (mm) 頭部寸法 (mm)						
	M3	M4	M5	M6	M8	M10	M12
S	2.5	3	4	5	6	8	10
d_k	5.5	7	8.5	10	13	16	18
K	3	4	5	6	8	10	12
Screw part length b_{max} ねじ部長さ b_{max}	18	20	22	24	28	32	36

FIGURE ZZD MECHANICAL STANDARD PARTS (NUTS)

3. Nuts ナット

How to read Parts Numbers
部品番号の見方

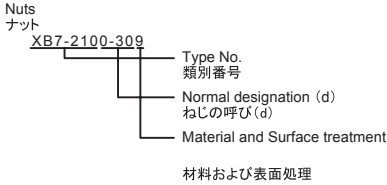

XB7-210 expresses Hexagon nut class 1.
XB7-210は、六角ナット1種を表す

0-30 expresses M3.0.
0-30は、M3.0を表す

9 expresses Steel (Black zinc trivalent chromate
treating) from Table 1.
9は、表1より鋼(黒色亜鉛3価クロメート)を表す

3-1. Hexagon Nuts and Hexagon Thin Nuts 六角ナット

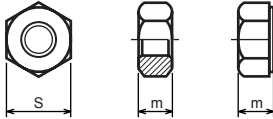

Type No. 類別番号	Type 類別
XB7-210	Hexagon nut Class 1 六角ナット-1種
XB7-220	Hexagon nut Class 3 六角ナット-3種
XB7-230	Hexagon nut Style 1 double chamfered 六角ナット-スタイル1-両面とり
XB7-231	Hexagon nut Style 1 washer faced 六角ナット-スタイル1-座付き
XB7-240	Hexagon nut Style 2 double chamfered 六角ナット-スタイル2-両面とり
XB7-241	Hexagon nut Style 2 washer faced 六角ナット-スタイル2-座付き
XB7-250	Hexagon nut 六角ナット
XB7-260	Hexagon thin nut double chamfered 六角低ナット-両面とり
XB7-270	Hexagon thin nut not chamfered 六角低ナット-面とり無し

	Head size (mm) 頭部寸法 (mm)						
	M2	M2.5	M3	M4	M5	M6	M8
S	4	5	5.5	7	8	10	13
m XB7-210	1.6	2	2.4	3.2	4	5	6.5
m XB7-220	1.2	1.6	1.8	2.4	3.2	3.6	5
m XB7-230, 231	1.6	2	2.4	3.2	4.7	5.2	6.8
m XB7-240, 241	-	-	-	-	5.1	5.7	7.5
m XB7-250	-	-	-	-	5.6	6.1	7.9
m XB7-260	1.2	1.6	1.8	2.2	2.7	3.2	4
m XB7-270	1.2	1.6	1.8	2.2	2.7	3.2	4

FIGURE ZZE MECHANICAL STANDARD PARTS (RETAINING RINGS)

5. Retaining Rings

止め輪

How to read Parts Numbers
部品番号の見方

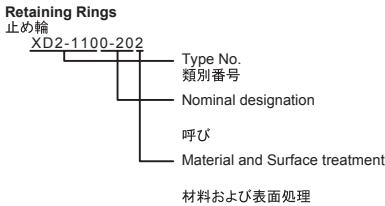

XD2-110 expresses retaining ring-E type (Type1).
XD2-110は、E形止め輪(1種)を表す

0-20 expresses a 020 of nominal designation.
(See Table 5)

0-20は、呼び020を表す(表5参照)

2 expresses Stainless steel (Surface treatment is not to be given) from Table 1.

2は、表1よりステンレス(表面処理なし)を表す

5-1. Retaining Rings - E type

E形止め輪

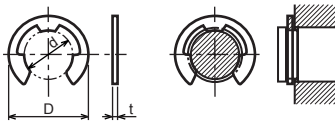

Type No. 類別番号	Type 類別
XD2-110	Retaining ring - E type (Type 1) E形止め輪(1種)
XD2-120	Retaining ring - E type (Type 2) E形止め輪(2種)

Table 5 表5

Type 種類	Nominal designation 呼び	d (mm)	D (mm)	t (mm)
Type 1 1種	007	0.65	2	0.2
	010	0.95	2.8	0.2
	013	1.25	3.3	0.3
	017	1.65	4.2	0.4
	020	1.95	4.6	0.5
	024	2.35	6	0.6
	028	2.74	6.5	0.6
	032	3.14	7.2	0.6
	037	3.64	8	0.7
	040	3.93	10	0.7
	042	4.13	10	0.7
	050	4.93	11	0.7
	058	5.73	12	0.7
	060	5.93	12.7	0.9
	064	6.32	13.5	0.9
	074	7.31	15	0.9
080	7.91	16.5	1	
Type 2 2種	008	0.8	2	0.2
	012	1.2	3	0.3
	015	1.5	4	0.4
	020	2	5	0.4
	025	2.5	6	0.4
	030	3	7	0.6
	040	4	9	0.6
	050	5	11	0.6
	060	6	12	0.8
	070	7	14	0.8
	080	8	16	0.8
	090	9	18	0.8
	100	10	20	1

5-2. Grip Rings
グリップ止め輪

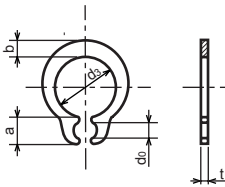

Type No. 類別番号	Type 類別
XD2-210	Grip ring グリップ止め輪

Table 5 表5

Nominal designation 呼び	d ₃ (mm)	t (mm)	b (mm)	a (mm)	d ₀ (mm)
020	1.9	0.5	1	1.8	0.8
025	2.35	0.5	1.2	1.9	0.9
030	2.85	0.6	1.4	1.9	0.9
035	3.3	0.6	1.6	2	0.9
040	3.8	0.8	1.8	2.8	1.2
045	4.25	0.8	2	2.9	1.3
050	4.75	0.8	2.2	2.9	1.3
060	5.7	1	2.4	3.1	1.4
070	6.7	1	2.7	3.3	1.4
080	7.7	1	3	3.5	1.4
090	8.65	1.2	3.3	4.7	1.5
100	9.65	1.2	3.5	4.7	2

5-3. Toothed Retaining Rings
歯付き形止め輪

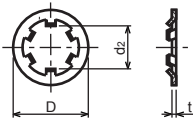

Type No. 類別番号	Type 類別
XD2-230	Toothed retaining ring 歯付き形止め輪

Table 5 表5

Nominal designation 呼び	d _z (mm)	D (mm)	t (mm)	No of teeth 歯数
015	1.4	5.2	0.25	3
020	1.9	6	0.25	3
024	2.3	6.4	0.25	3
030	2.8	8	0.25	4
040	3.8	9	0.25	4
050	4.8	10	0.25	5
060	5.8	11	0.25	5
080	7.8	13	0.25	5
100	9.8	15.4	0.25	6

5-4. Retaining Rings - C Type

C形止め輪

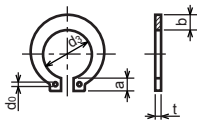

Type No. 類別番号	Type 類別
XD2-310	Retaining ring - C type for shaft C形止め輪 軸用

Table 5 表5

Nominal designation 呼び	d ₃ (mm)	t (mm)	b (mm)	a (mm)	d ₀ (mm)
010	9.3	1	1.6	3	1.2
012	11.1	1	1.8	3.2	1.5
014	12.9	1	2	3.4	1.7
015	13.8	1	2.1	3.5	1.7
016	14.7	1	2.2	3.6	1.7
017	15.7	1	2.2	3.7	1.7
018	16.5	1.2	2.6	3.8	1.7
020	18.5	1.2	2.7	3.9	2
022	20.5	1.2	2.7	4.1	2
025	23.2	1.2	3.1	4.3	2
028	25.9	1.5	3.1	4.6	2
030	27.9	1.5	3.5	4.8	2
032	29.6	1.5	3.5	5	2.5
035	32.2	1.5	4	5.4	2.5

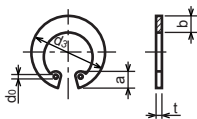

Type No. 類別番号	Type 類別
XD2-320	Retaining ring - C type for hole C形止め輪 穴用

Table 5 表5

Nominal designation 呼び	d ₃ (mm)	t (mm)	b (mm)	a (mm)	d ₀ (mm)
010	10.7	1	1.8	3.1	1.2
011	11.8	1	1.8	3.2	1.2
012	13	1	1.8	3.3	1.5
014	15.1	1	2	3.6	1.7
016	17.3	1	2	3.7	1.7
018	19.5	1	2.5	4	1.7
019	20.5	1	2.5	4	2
020	21.5	1	2.5	4	2
022	23.5	1	2.5	4.1	2
025	26.9	1.2	3	4.4	2
028	30.1	1.2	3	4.6	2
030	32.1	1.2	3	4.7	2
032	34.4	1.2	3.5	5.2	2.5
035	37.8	1.5	3.5	5.2	2.5
037	39.8	1.5	3.5	5.2	2.5
040	43.5	1.8	4	5.7	2.5
042	45.5	1.8	4	5.8	2.5
045	48.5	1.8	4.5	5.9	2.5
047	50.5	1.8	4.5	6.1	2.5
050	54.2	2	4.5	6.5	2.5
052	56.2	2	5.1	6.5	2.5
055	59.2	2	5.1	6.5	2.5
060	64.2	2	5.1	6.8	2.5
062	66.2	2	5.5	6.9	2.5
068	72.5	2.5	6	7.4	2.5
072	76.5	2.5	6.6	7.4	2.5
075	79.5	2.5	6.6	7.8	2.5
080	85.5	2.5	7	8	2.5
085	90.5	3	7	8	3
090	95.5	3	7.6	8.3	3
095	100.5	3	8	8.5	3

Prepared by
OIP Service Management Center
CANON INC.

Canon