

PARTS CATALOG

**LBP7680Cx/7660Cdn/
7600C/LBP7210Cdn**

Canon

Apr 9 2014

PREFACE

This Parts Catalog contains listings of parts used

Diagrams are provided with the listings to aid the service technician in identifying clearly, the item to be ordered.

Whenever ordering parts, consult this Parts Catalog for all of the information pertaining to each item. Be sure to include, in the Parts Request, the full item description, the item part number, and the quantity.

COPYRIGHT (C) 1999 CANON INC.

Use of this manual should be strictly supervised to avoid disclosure of confidential information.

Contents

NUMERICAL INDEX

LBP7680Cx/7660Cdn/7600C/LBP7210Cdn(Numerical Index)..... 1-1

LBP7680Cx/7660Cdn/7600C/LBP7210Cdn(Parts Catalog)

A1	ASSEMBLY LOCATION DIAGRAM	2-1
A2	OPTION PARTS CATALOG LIST	2-2
001	ACCESSORIES	2-3
100	EXTERNAL COVERS, PANELS, ETC.	2-5
101	INTERNAL COMPONENTS 1	2-8
102	INTERNAL COMPONENTS 2	2-10
103	INTERNAL COMPONENTS 3	2-12
104	INTERNAL COMPONENTS 4	2-14
105	INTERNAL COMPONENTS 5	2-16
106	INTERNAL COMPONENTS 6	2-18
300	CASSETTE	2-20
460	LASER SCANNER ASS'Y	2-21
530	INTERMEDIATE TRANS. BELT ASS'Y	2-22
810	FIXING ASS'Y	2-23
900	MAIN CONTROLLER PCB ASS'Y	2-25
ZZA	MECHANICAL STANDARD PARTS (HOW TO USE)	2-27
ZZB	MECHANICAL STANDARD PARTS (SCREWS)	2-28
ZZC	MECHANICAL STANDARD PARTS (BOLTS)	2-35
ZZD	MECHANICAL STANDARD PARTS (NUTS)	2-36
ZZE	MECHANICAL STANDARD PARTS (RETAINING RINGS)	2-37

NUMERICAL INDEX

LBP7680Cx/7660Cdn/7600C/LBP7210Cdn(Numerical Index)

PARTS NUMBER	FIGURE & KEY NO.	PARTS NUMBER	FIGURE & KEY NO.	PARTS NUMBER	FIGURE & KEY NO.
FC0-3865-000	100 - 1	FM0-3420-000	900 -	RC2-3390-000	103 - 20
FC0-3866-000	100 - 2	FM0-3571-000	103 - 7	RC2-3393-000	101 - 18
FC0-3870-000	100 - 6	FM0-4099-000	900 -	RC2-3395-000	102 - 5
FC0-3871-000	100 - 7	FM1-D561-000	810 -	RC2-3396-000	102 - 6
FC0-3873-010	100 - 3	FM1-E135-000	100 - 8	RC2-3401-000	103 - 21
FC0-3874-000	100 - 4	FM1-E136-000	100 - 8	RC2-3423-000	103 - 22
FC0-3875-000	100 - 15	FM3-8292-000	810 - 1	RC2-3508-000	103 - 18
FC0-3878-000	100 - 13	FM3-8293-000	810 -	RC2-3555-000	103 - 26
FC0-3879-000	100 - 5	FM3-8295-000	810 -	RC2-3556-000	103 - 23
FC0-3881-000	106 - 1	FM3-8296-000	810 -	RC2-3719-000	100 - 10
FC0-3882-000	105 - 10	FM4-3062-000	810 - 1	RC2-3750-000	106 - 4
FC0-3887-000	100 - 17	FM4-3063-000	810 - 1	RC2-3752-000	106 - 5
FC0-3888-000	100 - 14	FM4-3359-000	460 -	RC2-3774-000	106 - 6
FC0-3897-000	100 - 18	FM4-8501-000	100 - 9	RC2-3800-000	101 - 11
FC0-3905-000	101 - 16	FM4-8503-000	106 - 3	RC2-3801-000	101 - 12
FC0-3908-000	100 - 19	FM4-8504-000	300 -	RK2-1302-000	001 - 4
FC0-3909-000	100 - 20	FM4-8505-000	100 - 8	RK2-2276-000	100 - 12
FC0-3916-000	100 - 4	FM4-8506-000	100 - 8	RK2-2276-000	106 - 7
FC0-3919-000	101 - 15	FM4-8507-000	100 - 8	RK2-2302-000	104 - 2
FC0-3943-000	103 - 17	FM4-8508-000	100 - 8	RK2-3267-000	101 - 1
FC0-3944-000	103 - 13	FM4-8509-000	100 - 8	RL1-1785-000	103 - 3
FC8-8741-000	100 - 21	FM4-8510-000	100 - 8	RL1-1800-000	104 - 4
FC8-8742-000	100 - 11	FM4-8513-000	103 - 1	RL1-1802-000	102 - 1
FC8-8743-000	810 - 2	FM4-8514-000	103 - 5	RL1-3053-000	104 - 5
FC8-8745-000	100 - 11	FM4-8515-000	105 - 2	RM1-4836-000	101 - 2
FC8-8748-000	103 - 12	FM4-8516-000	100 - 8	RM1-4838-000	106 - 8
FC9-6974-000	001 - 3	FM4-8868-000	101 - 17	RM1-4840-000	103 - 6
FE3-8643-000	810 - 5	FM4-8869-000	101 - 4	RM1-4850-000	102 - 2
FH2-7080-000	001 - 2	FM4-8872-000	105 - 12	RM1-4852-000	530 -
FH2-7082-000	001 - 2	FM4-9356-000	104 - 1	RM1-4876-000	106 - 9
FK2-1316-000	001 - 2	FM4-9357-000	104 - 14	RM1-4877-000	106 - 10
FK2-4390-000	001 - 2	FM4-9358-000	104 - 14	RM1-4879-000	106 - 11
FK2-7852-000	900 - IC	FM4-9361-000	104 - 28	RM1-4880-000	106 - 12
FK2-8341-000	105 - 11	FM4-9372-000	104 - 6	RM1-4896-000	105 - 3
FK2-9583-000	001 - 2	FU7-8873-000	106 - 14	RM1-5293-000	104 - 7
FK3-1797-000	101 - 14	FU7-8875-000	106 - 15	RM1-5294-050	101 - 3
FK3-1800-000	900 - IC	NPN	001 -	RM1-5368-000	104 - 8
FK3-1801-000	900 - IC	NPN	100 -	RM1-5385-000	104 - 9
FK3-1986-000	104 - 27	NPN	101 -	RM1-5393-000	104 - 10
FK3-2146-000	104 - 3	NPN	102 -	RM1-5394-000	104 - 11
FK3-2249-000	101 - 13	NPN	103 -	RM1-5395-000	104 - 12
FK4-1032-000	001 - 1	NPN	104 -	RM1-5398-000	101 - 6
FK4-1033-000	001 - 1	NPN	105 -	RM1-5399-000	101 - 5
FK4-1223-000	001 - 1	NPN	106 -	RM1-5400-000	104 - 13
FK4-1225-000	001 - 1	RC2-2014-000	103 - 2	RM1-5419-000	105 - 5
FK4-1603-000	001 - 1	RC2-3220-000	104 - 17	RM1-5420-000	102 - 4
FK4-1604-000	001 - 1	RC2-3221-000	104 - 25	RM1-5428-000	103 - 8
FK4-1605-000	001 - 1	RC2-3222-000	104 - 29	RM1-5434-000	104 - 15
FK4-1606-000	001 - 1	RC2-3367-000	810 - 3	RM1-5435-000	104 - 16
FK4-1608-000	001 - 1	RC2-3386-000	103 - 14	RM1-5438-000	104 - 18
FM0-3418-010	900 -	RC2-3387-000	103 - 15	RM1-7355-000	105 - 4
FM0-3419-010	900 -	RC2-3388-000	103 - 16	RM1-7356-000	105 - 7

NUMERICAL INDEX

LBP7680Cx/7660Cdn/7600C/LBP7210Cdn(Numerical Index)

PARTS NUMBER	FIGURE & KEY NO.	PARTS NUMBER	FIGURE & KEY NO.	PARTS NUMBER	FIGURE & KEY NO.
RM1-8042-010	104 - 26				
RM1-8047-030	103 - 4				
RU6-2174-000	103 - 24				
RU6-2176-000	101 - 19				
RU6-2192-000	103 - 19				
RU6-2205-000	103 - 25				
VS1-7584-006	106 - 2				
WE8-5689-000	001 - 5				
WG8-5696-000	810 - 4				
WG8-5935-000	101 - 7				
WG8-5935-000	103 - 9				
WG8-5935-000	104 - 19				
XA9-0679-000	104 - 20				
XA9-0679-000	105 - 8				
XA9-1418-000	104 - 24				
XA9-1418-000	105 - 6				
XA9-1420-000	101 - 8				
XA9-1420-000	104 - 21				
XA9-1671-000	100 - 16				
XA9-1671-000	101 - 10				
XA9-1671-000	102 - 3				
XA9-1671-000	103 - 11				
XA9-1671-000	104 - 23				
XA9-1671-000	105 - 1				
XA9-1671-000	106 - 13				
XA9-1835-000	101 - 9				
XA9-1835-000	103 - 10				
XA9-1835-000	104 - 22				
XA9-1835-000	105 - 9				

LBP7680Cx/7660Cdn/7600C/ LBP7210Cdn(Parts Catalog)

Satera LBP7600C

100V JP F15-9812-000 MKAA002001-

Color imageCLASS LBP7660Cdn

120V US F15-9832-000 MKJA002001-

imageCLASS LBP7680Cx

230V ASIA F15-9841-000 MKDA002001-

230V AU F15-9841-000 MKGA002001-

imageCLASS LBP7660Cdn

230V ASIA F15-9842-000 MKEA002001-

230V CN F15-9852-000 MKFA002001-

i-SENSYS LBP7680Cx

230V EUR F15-9891-000 -MKBA800000

230V EUR F15-9893-000 MKBA800001-

i-SENSYS LBP7660Cdn

230V EUR F15-9892-000 -MKCA800000

230V EUR F15-9894-000 MKCA800001-

i-SENSYS LBP7210Cdn

230V EUR

F15-9896-000 MTKA002001-

Contents

A1	ASSEMBLY LOCATION DIAGRAM	2-1
A2	OPTION PARTS CATALOG LIST	2-2
001	ACCESSORIES	2-3
100	EXTERNAL COVERS, PANELS, ETC.	2-5
101	INTERNAL COMPONENTS 1	2-8
102	INTERNAL COMPONENTS 2	2-10
103	INTERNAL COMPONENTS 3	2-12
104	INTERNAL COMPONENTS 4	2-14
105	INTERNAL COMPONENTS 5	2-16
106	INTERNAL COMPONENTS 6	2-18
300	CASSETTE	2-20
460	LASER SCANNER ASS'Y	2-21
530	INTERMEDIATE TRANS. BELT ASS'Y.....	2-22
810	FIXING ASS'Y	2-23
900	MAIN CONTROLLER PCB ASS'Y	2-25
ZZA	MECHANICAL STANDARD PARTS (HOW TO USE)	2-27
ZZB	MECHANICAL STANDARD PARTS (SCREWS).....	2-28
ZZC	MECHANICAL STANDARD PARTS (BOLTS).....	2-35
ZZD	MECHANICAL STANDARD PARTS (NUTS).....	2-36
ZZE	MECHANICAL STANDARD PARTS (RETAINING RINGS)	2-37

FIGURE A1 ASSEMBLY LOCATION DIAGRAM

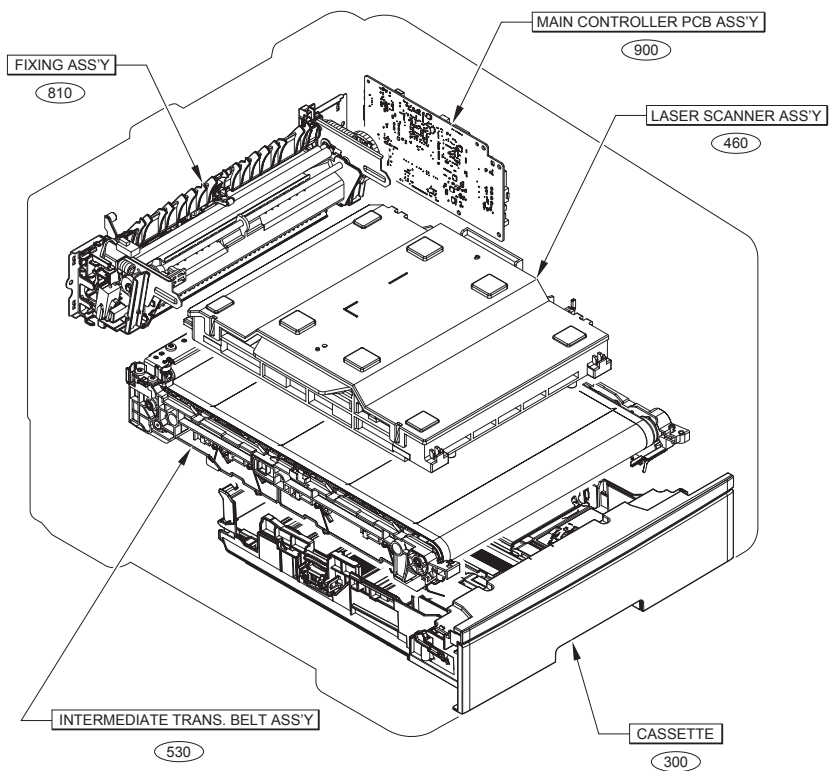

FIGURE A2 OPTION PARTS CATALOG LIST

This is the table of the machine's options whose parts catalog is issued.
本機のオプションで、パーツカタログが発行されている機種の一覧である。

No.	Model Name(English)	Model Name(Japanese)
1	Paper Feeder PF-701	ペーパーフィーダー PF-701

FIGURE 001 ACCESSORIES

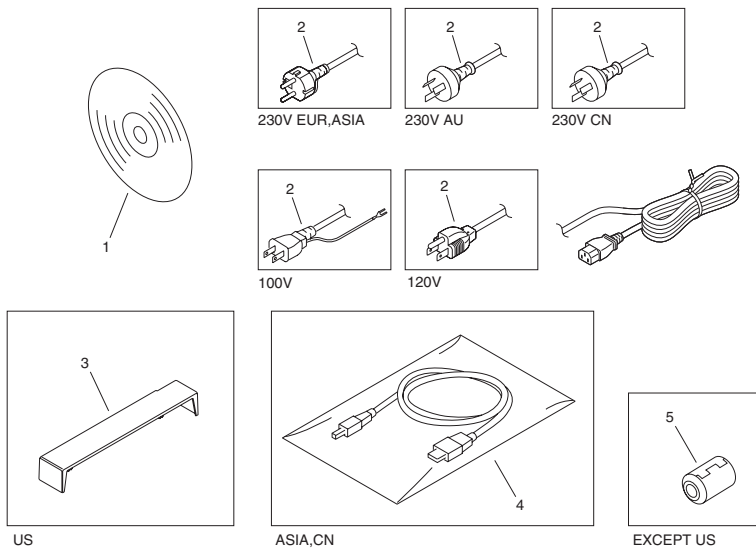

FIGURE & KEY NO.	PARTS NUMBER	RANK	Q'TY	DESCRIPTION	SERIAL NUMBER/REMARKS	SVC
Fig.001	NPN		RF	ACCESSORIES		
1	FK4-1033-000		1	CD-ROM, USER SOFTWARE	LBP7210Cdn English,Dutch,Danish,Norwegian,Finnish,Swedish,Polish	
1	FK4-1032-000		1	CD-ROM, USER SOFTWARE	LBP7210Cdn English,French,German,Italian,Spanish,Russian	
1	FK4-1603-000		1	CD-ROM, USER SOFTWARE	LBP7600CJapanese	
1	FK4-1608-000		1	CD-ROM, USER SOFTWARE	LBP7660CdnUS English, Spanish	
1	FK4-1604-000		1	CD-ROM, USER SOFTWARE	LBP7680Cx EUR MKBA800001- LBP7660Cdn EUR MKCA800001- English,French,German,Italian,Spanish	
1	FK4-1225-000		1	CD-ROM, USER SOFTWARE	LBP7680Cx English,Simplified Chinese,French,German,Italian,Spanish,Korean	
1	FK4-1223-000		1	CD-ROM, USER SOFTWARE	LBP7680Cx, LBP7660Cdn English, French, German,Italian, Spanish	
1	FK4-1605-000		1	CD-ROM, USER SOFTWARE	LBP7680Cx, LBP7660Cdn UK English,Simplified Chinese,Spanish	
1	FK4-1606-000		1	CD-ROM, USER SOFTWARE	LBP7680CxEnglish,Simplified Chinese,French,German,Italian,Spanish,Korean	
2	FK2-4390-000		1	CORD, POWER	100V	
2	FK2-9583-000		1	CORD, POWER	120V	
2	FH2-7082-000		1	CORD, POWER	230V AU	
2	FK2-1316-000		1	CORD, POWER	230V CN	
2	FH2-7080-000		1	CORD, POWER, 230V	230V EUR,ASIA	
3	FC9-6974-000		1	COVER, DUCT	US	
4	RK2-1302-000		1	CABLE, USB HOST POWER SUPPLY	ASIA,CN	
5	WE8-5689-000		1	FILTER, NOISE(RING CORE)	EXCEPT US	

FIGURE 100 EXTERNAL COVERS, PANELS, ETC.

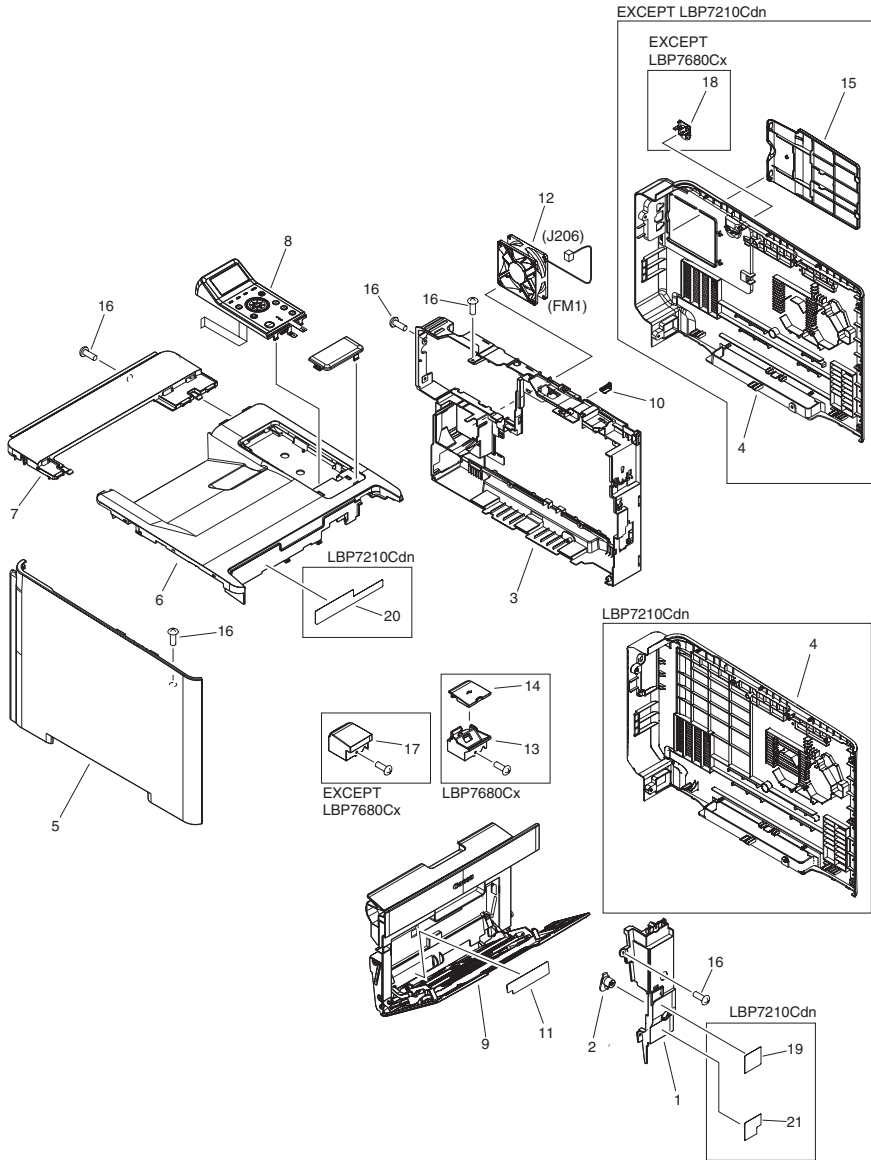

FIGURE & KEY NO.	PARTS NUMBER	R A N K	Q'TY	DESCRIPTION	SERIAL NUMBER/ REMARKS	S V C
Fig.100	NPN		RF	EXTERNAL COVERS, PANELS, ETC.		
1	FC0-3865-000		1	COVER, RIGHT FRONT		
2	FC0-3866-000		1	BUTTON, POWER		
3	FC0-3873-010		1	PANEL, RIGHT		
4	FC0-3874-000		1	COVER, RIGHT	EXCEPT LBP7210Cdn	
4	FC0-3916-000		1	COVER, RIGHT, L6	LBP7210Cdn	
5	FC0-3879-000		1	COVER, LEFT		
6	FC0-3870-000		1	COVER, TOP, FRONT		
7	FC0-3871-000		1	COVER, TOP, REAR		
8	FM4-8505-000		1	CONTROL PANEL ASS'Y	JP	
8	FM4-8516-000		1	CONTROL PANEL ASS'Y, L6	LBP7210Cdn	
8	FM4-8510-000		1	CONTROL PANEL ASS'Y	LBP7660Cdn CN	
8	FM4-8507-000		1	CONTROL PANEL ASS'Y	LBP7660Cdn EUR - MKCA800000	
8	FM1-E136-000		1	CONTROL PANEL ASS'Y	LBP7660Cdn EUR MKCA800001-	
8	FM4-8509-000		1	CONTROL PANEL ASS'Y	LBP7660Cdn US,ASIA	
8	FM4-8508-000		1	CONTROL PANEL ASS'Y	LBP7680Cx ASIA,AU	
8	FM4-8506-000		1	CONTROL PANEL ASS'Y	LBP7680Cx EUR - MKBA800000	
8	FM1-E135-000		1	CONTROL PANEL ASS'Y	LBP7680Cx EUR MKBA800001-	
9	FM4-8501-000		1	FRONT DOOR ASS'Y		
10	RC2-3719-000		1	BUTTON, TEST PRINT SWITCH		
11	FC8-8742-000		1	LABEL, PAPER SIZE	EXCEPT JP	
11	FC8-8745-000		1	LABEL, PAPER SIZE	JP	
12	RK2-2276-000		1	FAN	FM1	
13	FC0-3878-000		1	COVER, USB INNER	LBP7680Cx	
14	FC0-3888-000		1	COVER, USB	LBP7680Cx	
15	FC0-3875-000		1	COVER, DIMM ASS'Y	EXCEPT LBP7210Cdn	
16	XA9-1671-000		AR	SCREW, D, M3X8		
17	FC0-3887-000		1	COVER, USB BLANKING	EXCEPT LBP7680Cx	
18	FC0-3897-000		1	COVER, SD	EXCEPT LBP7680Cx/ LBP7210Cdn	

FIGURE & KEY NO.	PARTS NUMBER	R A N K	Q'TY	DESCRIPTION	SERIAL NUMBER/ REMARKS	S V C
19	FC0-3908-000		1	LABEL, JAM CLEARING, L6	LBP7210Cdn	
20	FC0-3909-000		1	LABEL, CARTRIDGE EXCHANGE, L6	LBP7210Cdn	
21	FC8-8741-000		1	LABEL, JAM CLEARING	LBP7210Cdn	

FIGURE 101 INTERNAL COMPONENTS 1

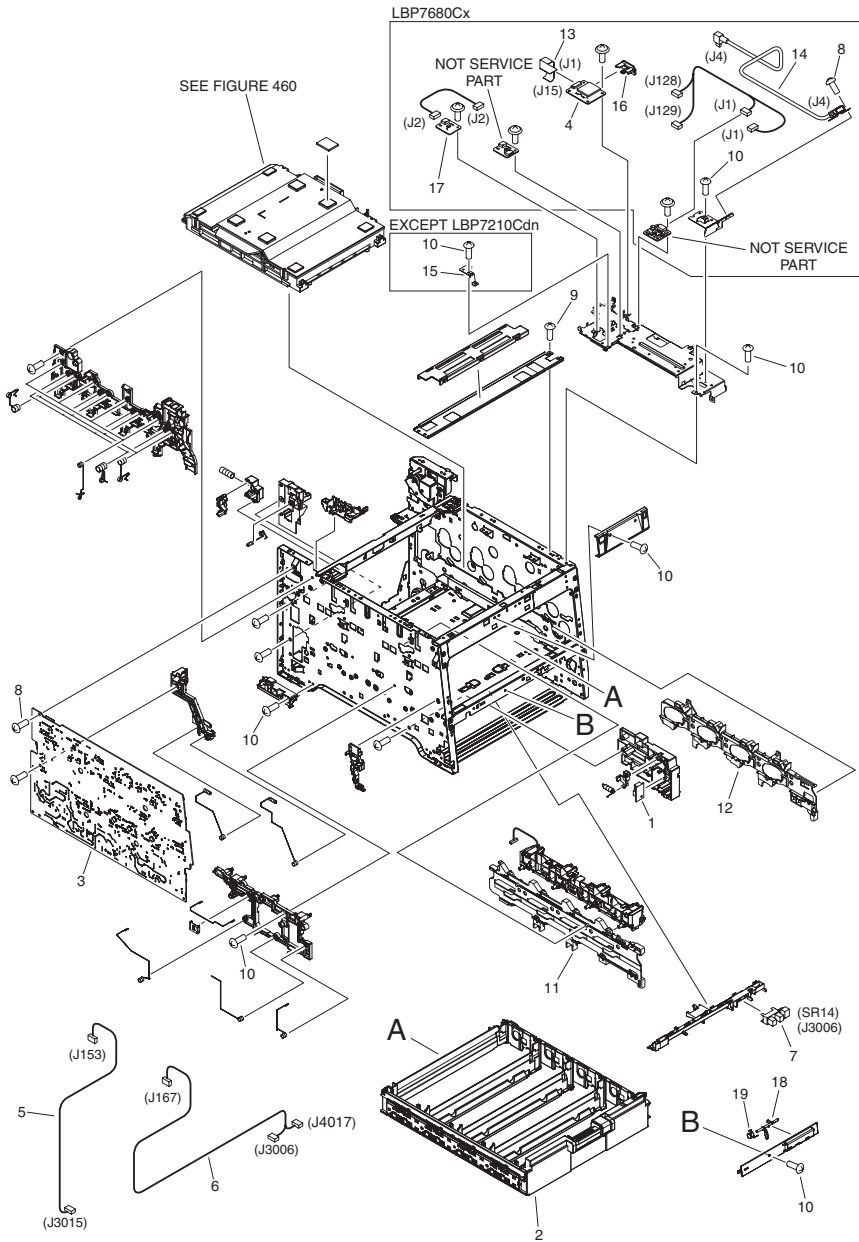

FIGURE & KEY NO.	PARTS NUMBER	R A N K	Q'TY	DESCRIPTION	SERIAL NUMBER/ REMARKS	S V C
Fig.101	NPN		RF	INTERNAL COMPONENTS 1		
1	RK2-3267-000		1	TEMPERATURE SENSOR UNIT		
2	RM1-4836-000		1	CARTRIDGE TRAY ASS'Y		
3	RM1-5294-050		1	H. V. POWER SUPPLY PCB ASS'Y		
4	FM4-8869-000		1	SD SLOT EXTENSION PCB ASSEMBLY	LBP7680Cx	
5	RM1-5399-000		1	ENV. SENSOR CABLE ASS'Y		
6	RM1-5398-000		1	SENSOR CABLE ASS'Y		
7	WG8-5935-000		1	PHOTO INTERRUPTER, TLP1243	SR14	
8	XA9-1420-000		4	SCREW, W/WASHER, M3X8		
9	XA9-1835-000		8	SCREW, D, M3X6		
10	XA9-1671-000		8	SCREW, D, M3X8		
11	RC2-3800-000		1	RAIL, LEFT		
12	RC2-3801-000		1	RAIL, RIGHT		
13	FK3-2249-000		1	CABLE, FLAT	LBP7680Cx	
14	FK3-1797-000		1	CABLE, USB	LBP7680Cx	
15	FC0-3919-000		1	PLATE, GROUNDING	EXCEPT LBP7210Cdn	
16	FC0-3905-000		1	GUIDE	LBP7680Cx	
17	FM4-8868-000		1	MEMORY PCB ASSEMBLY	LBP7680Cx	
18	RC2-3393-000		1	FLAG, SENSOR		
19	RU6-2176-000		1	SPRING, TORSION		

FIGURE 102 INTERNAL COMPONENTS 2

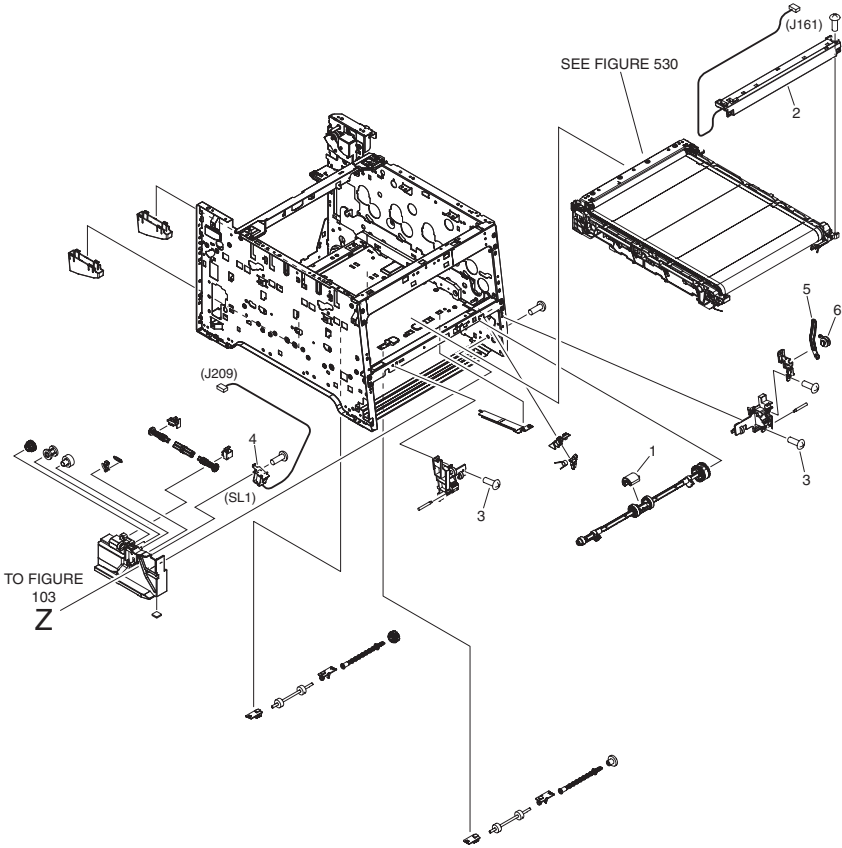

FIGURE & KEY NO.	PARTS NUMBER	RANK	Q'TY	DESCRIPTION	SERIAL NUMBER/REMARKS	SVC
Fig.102	NPN		RF	INTERNAL COMPONENTS 2		
1	RL1-1802-000		1	ROLLER, PAPER PICK-UP		
2	RM1-4850-000		1	COLOR MISREGIST. SENSOR ASS'Y		
3	XA9-1671-000		5	SCREW, D, M3X8		
4	RM1-5420-000		1	MP SOLENOID ASS'Y	SL1	
5	RC2-3395-000		1	HINGE, MULTI-PURPOSE COVER		
6	RC2-3396-000		1	BUSHING		

FIGURE 103 INTERNAL COMPONENTS 3

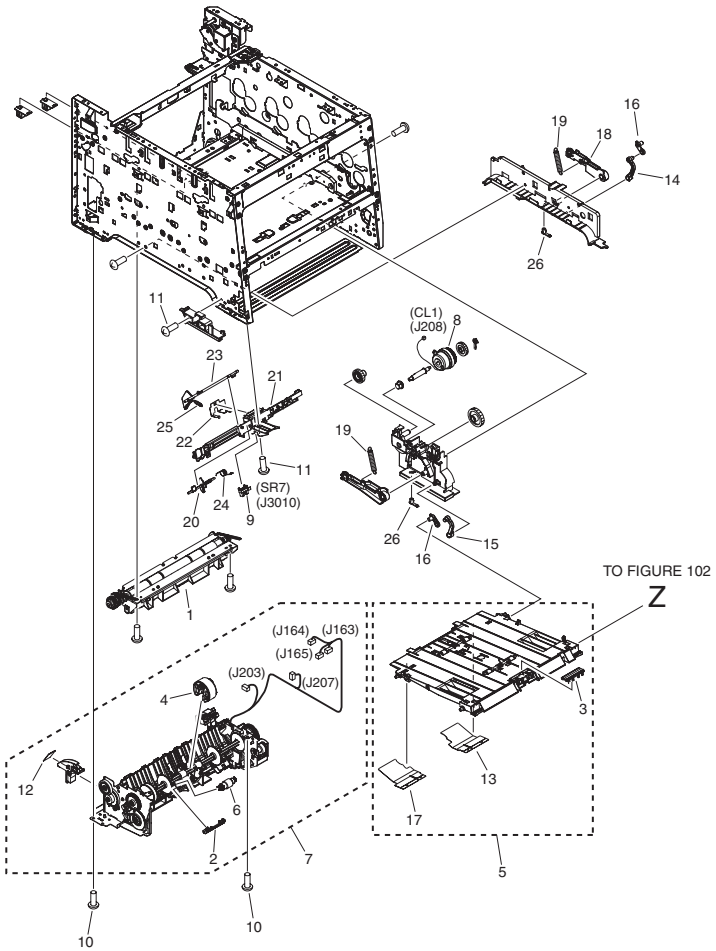

FIGURE & KEY NO.	PARTS NUMBER	RANK	Q'TY	DESCRIPTION	SERIAL NUMBER/REMARKS	SVC
Fig.103	NPN		RF	INTERNAL COMPONENTS 3		
1	FM4-8513-000		1	REGISTRATION ASS'Y		
2	RC2-2014-000		1	COVER, HOLDER		
3	RL1-1785-000		1	PAD, SEPARATION		
4	RM1-8047-030		1	PICK-UP ROLLER ASS'Y		
5	FM4-8514-000		1	MP PAPER PICK-UP ASS'Y		
6	RM1-4840-000		1	SEPARATION ROLLER ASS'Y		
7	FM0-3571-000		1	PAPER PICK-UP ASS'Y		
8	RM1-5428-000		1	MP CLUTCH ASS'Y	CL1	
9	WG8-5935-000		1	PHOTO INTERRUPTER, TLP1243	SR7	
10	XA9-1835-000		6	SCREW, D, M3X6		
11	XA9-1671-000		3	SCREW, D, M3X8		
12	FC8-8748-000		1	LABEL, MOTOR CAUTION		
13	FC0-3944-000		1	SHEET, GUIDE, RIGHT		
14	RC2-3386-000		1	ARM, TRAY, LEFT		
15	RC2-3387-000		1	ARM, TRAY, RIGHT		
16	RC2-3388-000		2	ARM, TRAY		
17	FC0-3943-000		1	SHEET, GUIDE, LEFT		
18	RC2-3508-000		1	ARM, PRESSURE, LEFT		
19	RU6-2192-000		2	SPRING, TENSION		
20	RC2-3390-000		1	FLAG, SENSOR		
21	RC2-3401-000		1	HOLDER, SENSOR		
22	RC2-3423-000		1	PLATE, GROUNDING		
23	RC2-3556-000		1	ARM, SENSOR		
24	RU6-2174-000		1	SPRING, TORSION		
25	RU6-2205-000		1	SPRING, TENSION		
26	RC2-3555-000		2	STOPPER, ARM		

FIGURE 104 INTERNAL COMPONENTS 4

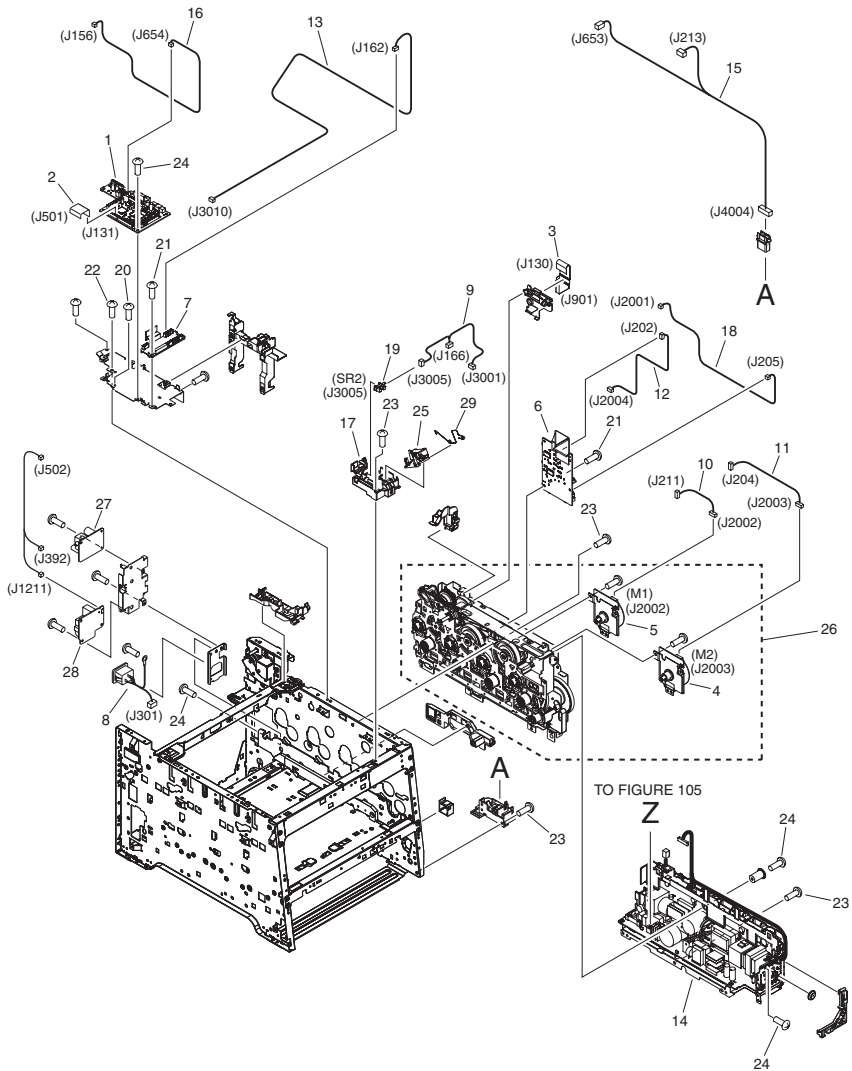
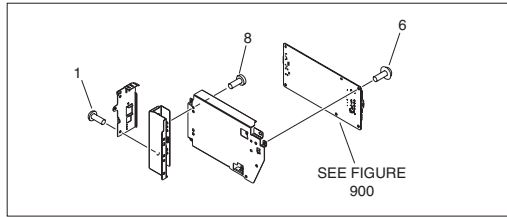

FIGURE & KEY NO.	PARTS NUMBER	R A N K	Q'TY	DESCRIPTION	SERIAL NUMBER/ REMARKS	S V C
Fig.104	NPN		RF	INTERNAL COMPONENTS 4		
1	FM4-9356-000		1	DC CONTROLLER PCB ASS'Y		
2	RK2-2302-000		1	CABLE, FLAT		
3	FK3-2146-000		1	CABLE, FLAT		
4	RL1-1800-000		1	MOTOR, DC	M2	
5	RL1-3053-000		1	MOTOR, DC	M1	
6	FM4-9372-000		1	DRIVER PCB ASS'Y		
7	RM1-5293-000		1	RELAY PCB ASS'Y		
8	RM1-5368-000		1	INLET CABLE ASS'Y		
9	RM1-5385-000		1	SENSOR CABLE ASS'Y		
10	RM1-5393-000		1	DRAM MOTOR CABLE ASS'Y		
11	RM1-5394-000		1	DEVELOPING MOTOR CABLE ASS'Y		
12	RM1-5395-000		1	FEED MOTOR CABLE ASS'Y		
13	RM1-5400-000		1	SENSOR CABLE ASS'Y		
14	FM4-9357-000		1	POWER SUPPLY ASS'Y	100V,120V	
14	FM4-9358-000		1	POWER SUPPLY ASS'Y	230V	
15	RM1-5434-000		1	OPTION CABLE ASS'Y		
16	RM1-5435-000		1	RLD CABLE ASS'Y		
17	RC2-3220-000		1	HOLDER, CARTRIDGE DOOR SENSOR		
18	RM1-5438-000		1	FIXING MOTOR CABLE ASS'Y		
19	WG8-5935-000		1	PHOTO INTERRUPTER, TLP1243	SR2	
20	XA9-0679-000		1	SCREW, MACH., FLAT HEAD, M3X4		
21	XA9-1420-000		4	SCREW, W/WASHER, M3X8		
22	XA9-1835-000		2	SCREW, D, M3X6		
23	XA9-1671-000		AR	SCREW, D, M3X8		
24	XA9-1418-000		8	SCREW, TP, M3X6		
25	RC2-3221-000		1	ARM, DOOR SENSOR		
26	RM1-8042-010		1	MAIN DRIVE ASS'Y		
27	FK3-1986-000		1	A.N. POWER SUPPLY PCB ASSEMBLY		
28	FM4-9361-000		1	AC CONNECTING PCB ASSEMBLY		
29	RC2-3222-000		1	SPRING, TORSION		

FIGURE 105 INTERNAL COMPONENTS 5

LBP7210Cdn



LBP7680Cx, LBP7660Cdn, LBP7600C

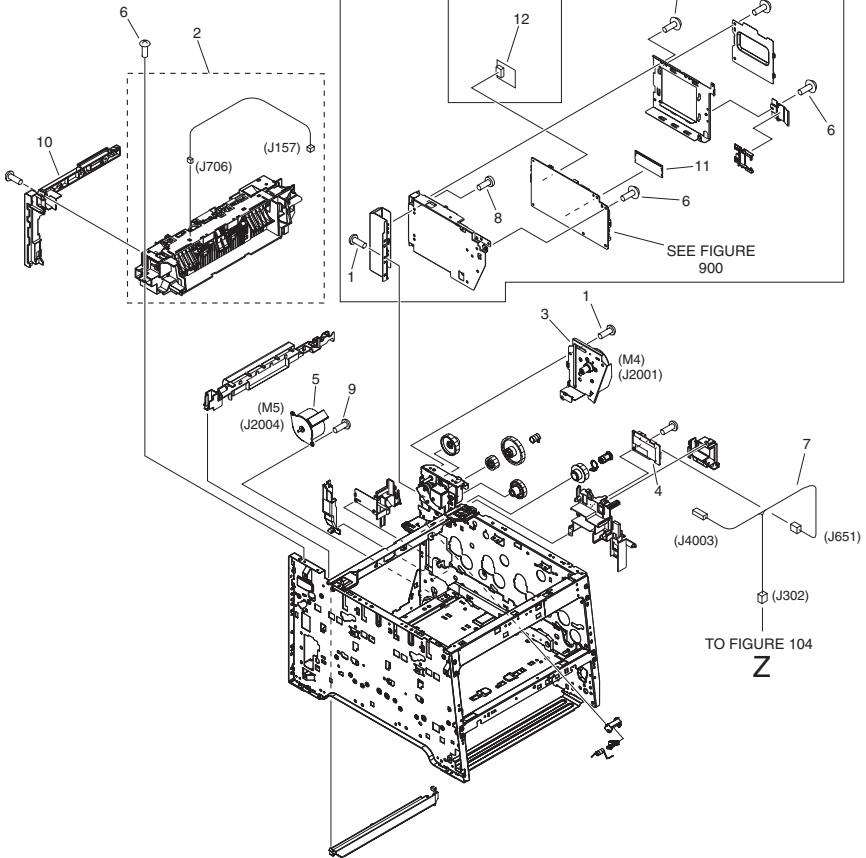
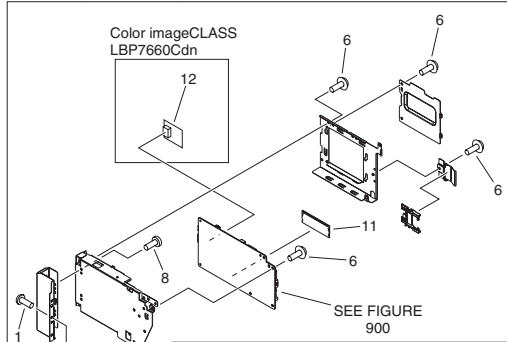

FIGURE & KEY NO.	PARTS NUMBER	R A N K	Q'TY	DESCRIPTION	SERIAL NUMBER/ REMARKS	S V C
Fig.105	NPN		RF	INTERNAL COMPONENTS 5		
1	XA9-1671-000		AR	SCREW, D, M3X8		
2	FM4-8515-000		1	PAPER DELIVERY ASS'Y		
3	RM1-4896-000		1	FIXING MOTOR UNIT	M4	
4	RM1-7355-000		1	POWER SUPPLY SUB PCB ASS'Y		
5	RM1-5419-000		1	REGISTRATION MOTOR ASS'Y	M5	
6	XA9-1418-000		5	SCREW, TP, M3X6		
7	RM1-7356-000		1	FUSER CABLE ASS'Y		
8	XA9-0679-000		5	SCREW, MACH., FLAT HEAD, M3X4		
9	XA9-1835-000		2	SCREW, D, M3X6		
10	FC0-3882-000		1	COVER, REAR, UPPER		
11	FK2-8341-000		1	DIMM, SMD-E51288HG-6E, SDRAM	LBP7680Cx.LBP7660Cdn, LBP7600C	
12	FM4-8872-000		1	ROM PCB ASSEMBLY	Color imageCLASS LBP7660Cdn	

FIGURE 106
INTERNAL COMPONENTS 6

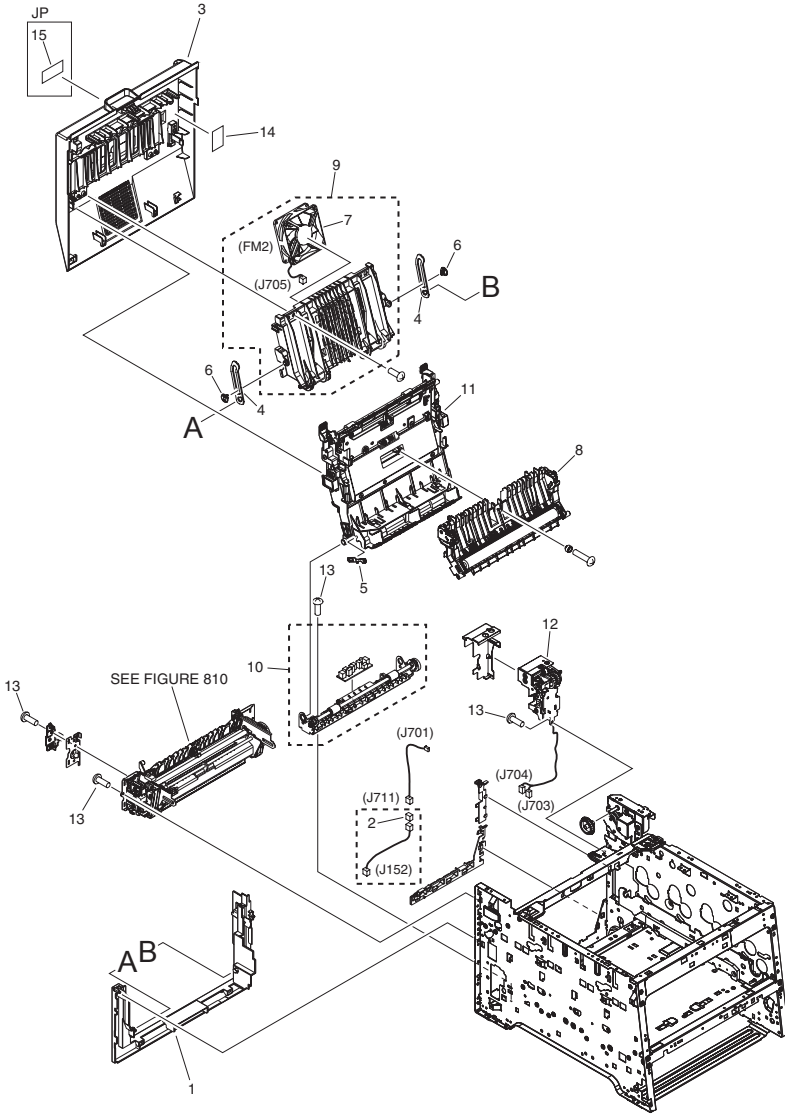

FIGURE & KEY NO.	PARTS NUMBER	R A N K	Q'TY	DESCRIPTION	SERIAL NUMBER/ REMARKS	S V C
Fig.106	NPN		RF	INTERNAL COMPONENTS 6		
1	FC0-3881-000		1	COVER, REAR, LOWER		
2	VS1-7584-006		1	CONNECTOR, SNAP TIGHT		
3	FM4-8503-000		1	REAR DOOR ASS'Y		
4	RC2-3750-000		2	LINK, DOOR		
5	RC2-3752-000		1	LINK, GUIDE		
6	RC2-3774-000		2	CAP. LINK		
7	RK2-2276-000		1	FAN	FM2	
8	RM1-4838-000		1	PAPER FEED GUIDE ASS'Y		
9	RM1-4876-000		1	REAR DOOR RIB ASS'Y		
10	RM1-4877-000		1	PAPER RE-PICK UP GUIDE ASS'Y		
11	RM1-4879-000		1	DUPLEXING FEED GUIDE ASS'Y		
12	RM1-4880-000		1	REVERSE DRIVE ASS'Y		
13	XA9-1671-000		7	SCREW, D, M3X8		
14	FU7-8873-000		1	LABEL, JAM CLEARING		
15	FU7-8875-000		1	LABEL, GROUNDING CAUTION	JP	

FIGURE 300 CASSETTE

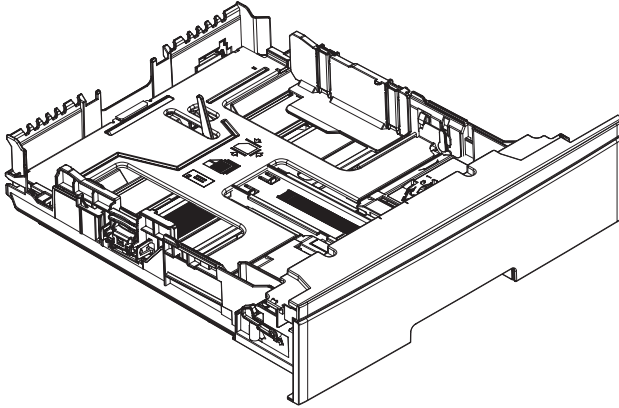

FIGURE & KEY NO.	PARTS NUMBER	RANK	QTY	DESCRIPTION	SERIAL NUMBER/REMARKS	SVC
Fig.300	FM4-8504-000		1	CASSETTE		

FIGURE 460 LASER SCANNER ASS'Y

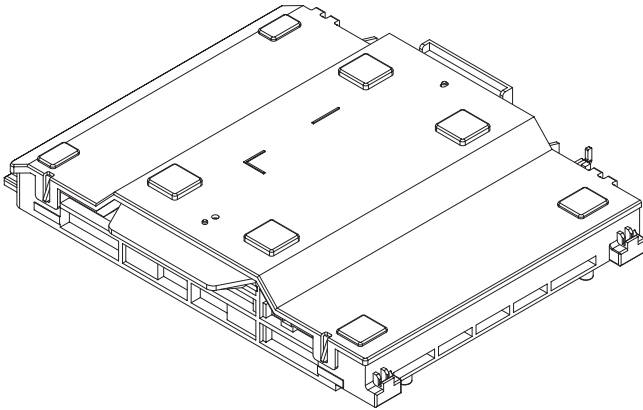

FIGURE & KEY NO.	PARTS NUMBER	RANK	Q'TY	DESCRIPTION	SERIAL NUMBER/REMARKS	SVC
Fig.460	FM4-3359-000		1	LASER SCANNER ASS'Y		

FIGURE 530 INTERMEDIATE TRANS. BELT ASS'Y

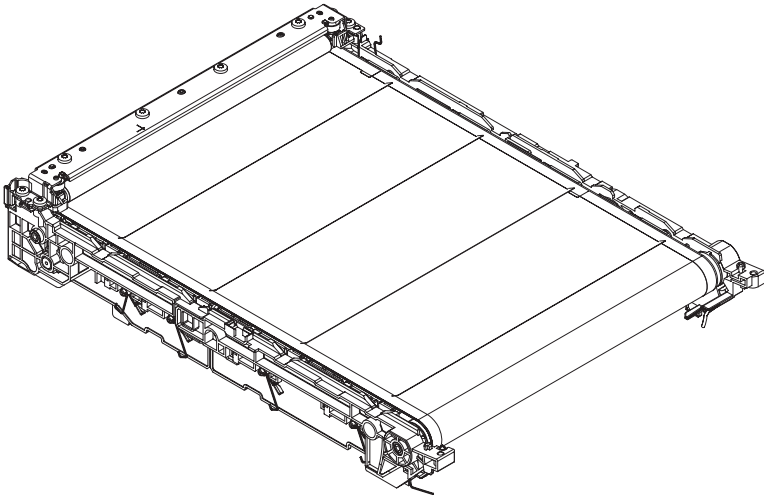

FIGURE & KEY NO.	PARTS NUMBER	RANK	QTY	DESCRIPTION	SERIAL NUMBER/ REMARKS	S V C
Fig.530	RM1-4852-000		1	INTERMEDIATE TRANS. BELT ASS'Y		

FIGURE 810
FIXING ASS'Y

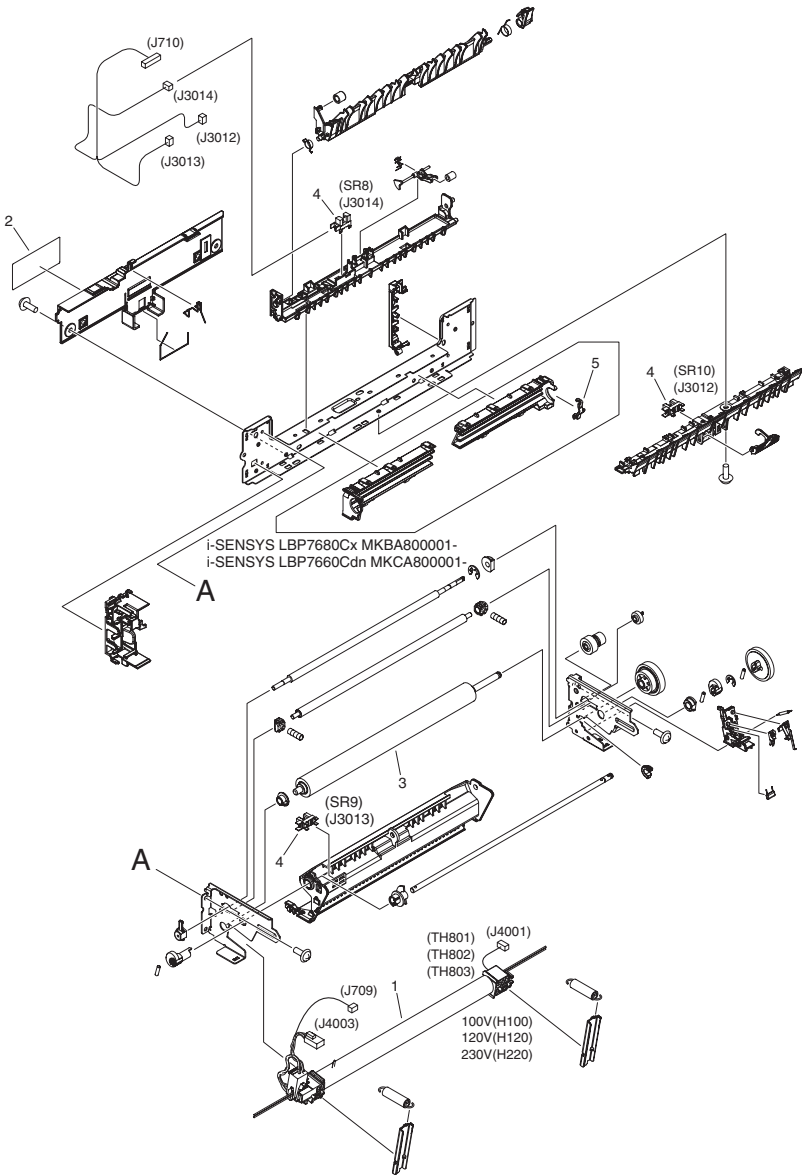
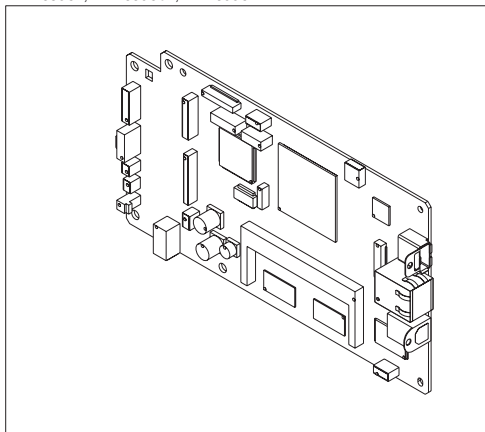

FIGURE & KEY NO.	PARTS NUMBER	R A N K	Q'TY	DESCRIPTION	SERIAL NUMBER/ REMARKS	S V C
Fig.810	FM3-8293-000		1	FIXING ASS'Y	100V	
Fig.810	FM3-8295-000		1	FIXING ASS'Y	120V	
Fig.810	FM3-8296-000		1	FIXING ASS'Y	230V EXCEPT i-SENSYS LBP7680Cx MKBA800001- i-SENSYS LBP7660Cdn MKCA800001-	
Fig.810	FM1-D561-000		1	FIXING ASS'Y	230V i-SENSYS LBP7680Cx MKBA800001- i-SENSYS LBP7660Cdn MKCA800001-	
1	FM3-8292-000		1	FIXING FILM ASSEMBLY	100V	
1	FM4-3062-000		1	FIXING FILM ASSEMBLY	120V	
1	FM4-3063-000		1	FIXING FILM ASSEMBLY	230V	
2	FC8-8743-000		1	LABEL, CAUTION		
3	RC2-3367-000		1	ROLLER, PRESSURE		
4	WG8-5696-000		3	PHOTO INTERRUPTER, TLP1243	SR8,SR9,SR10	
5	FE3-8643-000		1	GUIDE, PRESSURE, RIGHT UPPER	230V i-SENSYS LBP7680Cx MKBA800001- i-SENSYS LBP7660Cdn MKCA800001-	

FIGURE 900 MAIN CONTORROLLER PCB ASS'Y

LBP7680Cx,LBP7660Cdn,LBP7600C



LBP7210Cdn

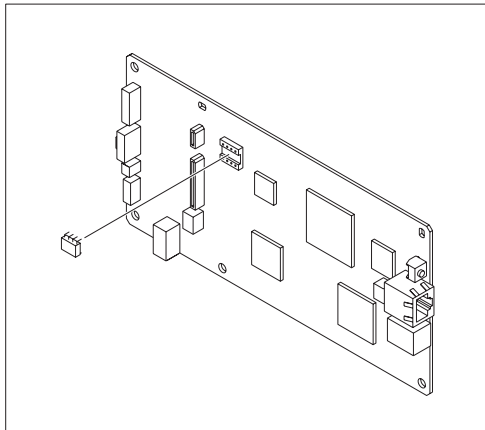

FIGURE & KEY NO.	PARTS NUMBER	RANK	Q'TY	DESCRIPTION	SERIAL NUMBER/ REMARKS	S V C
Fig.900	FM0-3418-010		1	MAIN CONTROLLER PCB ASSEMBLY	LBP7680Cx	
Fig.900	FM0-3419-010		1	MAIN CONTROLLER PCB ASSEMBLY	LBP7660Cdn	
Fig.900	FM0-3420-000		1	MAIN CONTROLLER PCB ASSEMBLY	LBP7600C	
Fig.900	FM0-4099-000		1	MAIN CONTROLLER PCB ASS'Y, L6	LBP7210Cdn	
IC	FK2-7852-000		1	IC, T6TH5EFG-0002(0), STANDARD	IC4	
IC	FK3-1800-000		1	IC, ASIC, MB8AA4241EPBH-GE1	IC13 LBP7680Cx	
IC	FK3-1801-000		1	IC, ASIC, MB8AA4241FPBH-GE1	IC13 LBP7660Cdn/ LBP7600C	

FIGURE ZZA

MECHANICAL STANDARD PARTS (HOW TO USE)

Mechanical standard parts

機械標準部品

About a mechanical standard parts

A Mechanical standard parts is a mechanical part which not parts peculiar to a product. They are parts which are common to a Canon product and are used, such as a screw and a washer. The Fig No. and parts number of the mechanical standard parts are not listed in the product parts catalog. Refer to the parts catalog of mechanical standard parts when checking the parts number for screw or washer etc. and identify them by part shape or size.

機械標準部品とは

機械標準部品とは、製品特有の部品ではなく、ねじやワッシャなどキヤノン製品共通で使用されている機械部品（メカ部品）のことです。
製品のパーツカタログには、機械標準部品のFig No.や部品番号は記載しておりません。
ねじや、ワッシャ等の部品番号を調べるときは、機械標準部品のパーツカタログを参照し、部品の形状や大きさから判断し、使用している部品を調べてください。

Material and surface treatment of a mechanical standard parts

Material and surface treatment of mechanical standard parts are assigned commonly for each part. Refer to the Table 1 for the parts which material and surface treatment are assigned as numbers.

機械標準部品の材料および表面処理

機械標準部品の材料および表面処理については、各種部品共通で決められています。
材料および表面処理が番号で決められている部品については、表1を参照してください。

Table 1 Material and Surface treatment
表1 材料および表面処理

No. 番号	Material 材料	Surface treatment 表面処理	Color 色
1	Stainless steel ステンレス	Stainless steel black coloring (BC4) ステンレス黒着色(BC4)	Black 黒
2		not to be given なし	White 白
3	Brass 黄銅	Regular nickel plating (NL) 普通ニッケルメッキ(NL)	White 白
4		Black nickel plating (BN) 黒色ニッケルメッキ(BN)	Black 黒
5	Steel 鋼	White zinc trivalent chromate treating (ZC3) 白色亜鉛3価クロメート(ZC3)	White 白
6		Regular nickel chromium plating (NC) 普通ニッケルクロムメッキ(NC)	White 白
7		Regular nickel plating (NL) 普通ニッケルメッキ(NL)	White 白
8		Iron and steel phosphating (P1) 鉄鋼磷酸塩処理(P1)	Black 黒
9		Black zinc trivalent chromate treating (BZ3) 黒色亜鉛3価クロメート(BZ3)	Black 黒

FIGURE ZZB MECHANICAL STANDARD PARTS (SCREWS)

1. Screws ねじ

How to read Parts Numbers
部品番号の見方

Screws
ねじ

XB1-2400-609

Type No.
類別番号
Normal designation (d)
ねじの呼び(d)
Length (L)
ねじの長さ(L)
Material and Surface treatment
材料および表面処理

XB1-2 expresses Binding head machine screw.
XB1-2は、バインドねじを表す
40 expresses M4.0.
40は、M4.0を表す
0-60 expresses a length of 6.0mm.
0-60は、6.0mmの長さを表す
9 expresses Steel (Black zinc trivalent chromate
treating) from Table 1.
9は、表1より鋼(黒色亜鉛3価クロメート)を表す

1-1. Cross Recessed Head Screws for Precision Equipments 精密機器用十字穴付き小ねじ

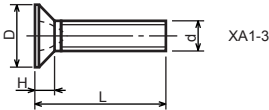
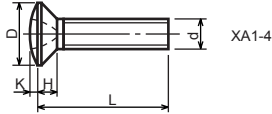
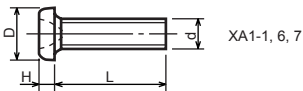

Type No. 類別番号	Type 類別	Head size (mm) 頭部寸法 (mm)							
		M1.4	M1.6	M1.7	M2	M2.5	M2.6		
XA1-1	Pan head Class 1 なべ1種	D	XA1-1	2	2.4	2.5	3	3.8	4
		H	XA1-1	0.5	0.55	0.5	0.6	0.9	0.8
XA1-3	Countersunk head Class 1 さら1種	D	XA1-3	2	2.4	2.5	3	3.8	4
		H	XA1-3	0.48	0.55	0.58	0.73	0.85	0.93
XA1-4	Oval countersunk head Class 1 丸さら1種	D	XA1-4	2	2.4	2.5	3	3.8	4
		H + K	XA1-4	0.68	0.8	0.88	1	1.25	1.3
XA1-6	Pan head Class 3 なべ3種	D	XA1-6	2.5	2.8	3	3.5	4.3	4.5
		H	XA1-6	0.8	0.85	0.9	1	1.3	1.2
XA1-7	Pan head Class 2 なべ2種	D	XA1-7	2.5	2.8	3	3.5	4.3	4.5
		H	XA1-7	0.5	0.55	0.5	0.6	0.9	0.8

1-2. Precision Tapping Screws
精密用タッピンねじ

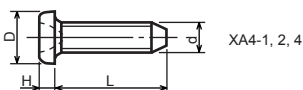

XA4-1, 2, 4



XA4-6, 7, 9

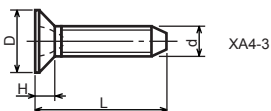

XA4-3

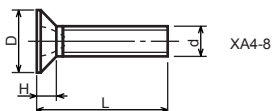

XA4-8

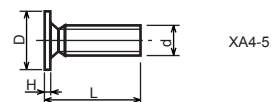

XA4-5

Type No. 類別番号	Type 類別	Head size (mm) 頭部寸法 (mm)						
		M1.4	M1.6	M1.7	M2	M2.5	M2.6	
XA4-1	With tapered end pan head Class 1 絞りなべ1種	D XA4-1	2	2.4	2.5	3	3.8	4
		H XA4-1	0.5	0.55	0.5	0.6	0.9	0.8
XA4-2	With tapered end pan head Class 3 絞りなべ3種	D XA4-2	2.5	2.8	3	3.5	4.3	4.5
		H XA4-2	0.8	0.85	0.9	1	1.3	1.2
XA4-3	With tapered end countersunk head 絞り-さら	D XA4-3	2	2.4	2.5	3	3.8	4
		H XA4-3	0.48	0.55	0.58	0.73	0.85	0.93
XA4-4	With tapered end pan head Class 2 絞りなべ2種	D XA4-4	2.5	2.8	3	3.5	4.3	4.5
		H XA4-4	0.5	0.55	0.5	0.6	0.9	0.8
XA4-5	With parallel end ultra thin head ストレート-超薄頭	D XA4-5	2.5	2.8	3	-	-	-
		H XA4-5	0.2	0.2	0.2	-	-	-
XA4-6	With parallel end pan head Class 1 ストレートなべ1種	D XA4-6	2	2.4	2.5	3	3.8	4
		H XA4-6	0.5	0.55	0.5	0.6	0.9	0.8
XA4-7	With parallel end pan head Class 3 ストレートなべ3種	D XA4-7	2.5	2.8	3	3.5	4.3	4.5
		H XA4-7	0.8	0.85	0.9	1	1.3	1.2
XA4-8	With parallel end countersunk head ストレート-さら	D XA4-8	2	2.4	2.5	3	3.8	4
		H XA4-8	0.48	0.55	0.58	0.73	0.85	0.93
XA4-9	With parallel end pan head Class 2 ストレートなべ2種	D XA4-9	2.5	2.8	3	3.5	4.3	4.5
		H XA4-9	0.5	0.55	0.5	0.6	0.9	0.8

1-3. Cross Recessed Head Screws
 一般用十字穴付き小ねじ

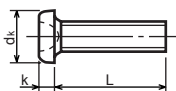

XB1-1

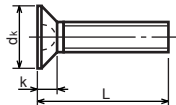

XB1-3

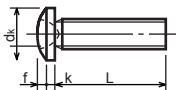

XB1-2

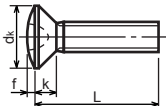

XB1-4

Type No. 類別番号	Type 類別
XB1-1	Pan head なべ
XB1-2	Binding head バインド
XB1-3	Countersunk head さら
XB1-4	Oval countersunk head 丸さら

		Head size (mm) 頭部寸法 (mm)					
		M2	M2.5	M2.6	M3	M4	M5
dk	XB1-1	3.5	4.5	4.5	5.5	7	9
k	XB1-1	1.3	1.7	1.7	2	2.6	3.3
dk	XB1-2	4.3	5.3	5.5	6.3	8.3	10.3
k+f	XB1-2	1.2	1.5	1.6	1.9	2.5	3.1
dk	XB1-3	4	5	-	6	8	10
k	XB1-3	1.2	1.45	-	1.75	2.3	2.8
dk	XB1-4	4	5	-	6	8	10
k+f	XB1-4	1.6	2	-	2.45	3.2	4
Screw part length ねじ部長さ b		8	12	12	12	16	20

1-4. Cross Recessed Head Screws with Captive Washer
座金組み込み十字穴付き小ねじ

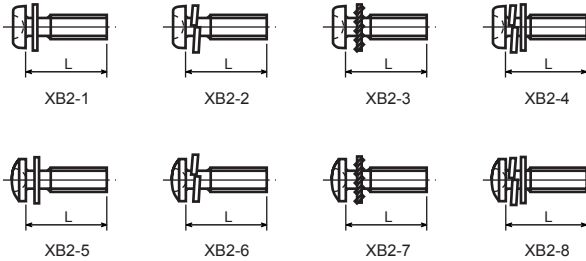

Type No. 類別番号	Type 類別
XB2-1	Pan head + Plain washer (circular bright) なべねじ+平座金
XB2-2	Pan head + Spring washer なべねじ+ばね座金
XB2-3	Pan head + Toothed lock washer なべねじ+歯付座金
XB2-4	Pan head + Spring washer and plain washer (circular bright) なべねじ+(ばね+平)座金
XB2-5	Binding head + Plain washer (circular bright) バインドねじ+平座金
XB2-6	Binding head + Spring washer バインドねじ+ばね座金
XB2-7	Binding head + Toothed lock washer バインドねじ+歯付座金
XB2-8	Binding head + Spring washer and plain washer (circular bright) バインドねじ+(ばね+平)座金

1-5. Hexagon Head Tapping Screws for Metallic Materials
 金属用六角タッピンねじ

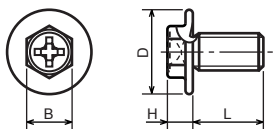

Type No. 類別番号	Type 類別	Head size (mm) 頭部寸法 (mm)	
		M3	M4
XB3-6	For metallic materials 金属用タッピン	D	8 10
		B	5.5 5.5
XB3-7	For metallic materials with clawed 金属用タッピン-つめ付き	H XB3-6	3.1 3.1
		H XB3-7	3.2 3.2

1-6. Special Tapping Screws
 特殊タッピンねじ

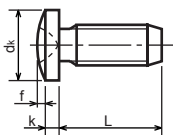

Type No. 類別番号	Type 類別	Head size (mm) 頭部寸法 (mm)	
		M3	M4
XB4-5	Binding head バインド	d _k	6.3 8.3
		k	1.3 1.7
		k+f	1.9 2.5

1-7. General Head Tapping Screws
 一般用タッピンねじ

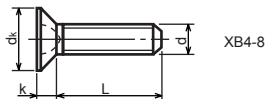
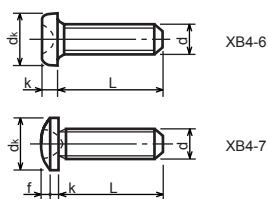

Type No. 類別番号	Type 類別	Head size (mm) 頭部寸法 (mm)						
		M2	M2.5	M2.6	M3	M4	M5	
XB4-6	Pan head なべ	d_k XB4-6	3.5	4.5	4.5	5.5	7	9
		k XB4-6	1.3	1.7	1.7	2	2.6	3.3
XB4-7	Binding head バインド	d_k XB4-7	4.3	5.3	5.5	6.3	8.3	10.3
		$k+f$ XB4-7	1.2	1.5	1.6	1.9	2.5	3.1
XB4-8	Countersunk head さら	d_k XB4-8	4	5	5.2	6	8	10
		k XB4-8	1.2	1.45	1.5	1.75	2.3	2.8

1-8. Tapping Screws for Metallic Materials
 金属用タッピンねじ

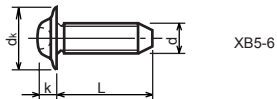
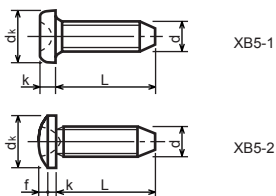

Type No. 類別番号	Type 類別	Head size (mm) 頭部寸法 (mm)					
		M2.5	M2.6	M3	M4	M5	
XB5-1	Pan head なべ	d_k XB5-1	4.5	4.5	5.5	7	9
		k XB5-1	1.7	1.7	2	2.6	3.3
XB5-2	Binding head バインド	d_k XB5-2	5.5	5.5	6.3	8.3	10.3
		$k+f$ XB5-2	1.6	1.6	1.9	2.5	3.1
XB5-6	Flanged pan head つば付きなべ	d_k XB5-6	6.5	6.5	8	10	12
		k XB5-6	2.1	2.1	1.75	3.2	4

1-9. Hexagon Socket Set Screws
六角穴付止めねじ

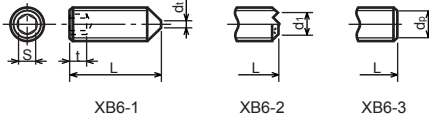

Type No. 類別番号	Type 類別	Head size (mm) 頭部寸法 (mm)							
		M1.6 M1.7	M2	M2.5 M2.6	M3	M5	M5	M6	
XB6-1	Cone point とがり先	S	0.7	0.9	1.3	1.5	2	2.5	3
		t	1.5	1.7	2	2	2.5	3	3.5
		$d_{t \max}$ XB6-1	0.4	0.5	0.65	0.75	1	1.25	1.5
		$d_{l \max}$ XB6-2	-	1.2	1.5	1.7	2.2	2.8	3.3
		$d_{l \min}$ XB6-2	-	1	1.2	1.4	1.9	2.4	2.9
XB6-2	Double point ダブルポイント	$d_{p \max}$ XB6-3	0.8	1	1.5	2	2.5	3.5	4
XB6-3	Flat point 平先	$d_{p \min}$ XB6-3	0.55	0.75	1.25	1.75	2.25	3.2	3.7

1-10. Flanged Pan Head Machine Screws
つば付きなべ小ねじ

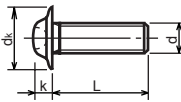

Type No. 類別番号	Type 類別	Head size (mm) 頭部寸法 (mm)					
		M2	M2.5 M2.6	M3	M5	M5	
XB6-7	Flanged pan head つば付きなべ	d_k	5	6.5	8	10	12
		k	1.7	2.1	2.5	3.2	4

FIGURE ZZC MECHANICAL STANDARD PARTS (BOLTS)

2. Bolts (Socket head cap screw) ボルト

How to read Parts Numbers
部品番号の見方

Bolt (Socket head cap screw)
ボルト

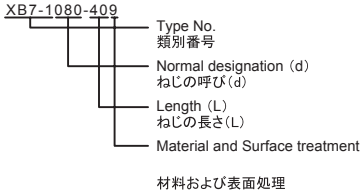

XB7-1 expresses Hexagon socket head cap screws.
XB7-1は、六角穴付きボルトを表す

080 expresses M8.0.
080は、M8.0を表す

40 expresses a length of 40mm.
40は、40mmの長さを表す

9 expresses Steel (Black zinc trivalent chromate
treating) from Table 1.

9は、表1より鋼(黒色亜鉛3価クロメート)を表す

2-1. Hexagon socket head cap screws 六角穴付きボルト

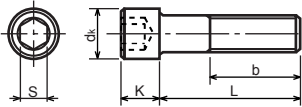

Type No. 類別番号	Type 類別
XB7-1	Hexagon socket head cap screws 六角穴付きボルト

	Head size (mm) 頭部寸法 (mm)						
	M3	M4	M5	M6	M8	M10	M12
S	2.5	3	4	5	6	8	10
d_k	5.5	7	8.5	10	13	16	18
K	3	4	5	6	8	10	12
Screw part length b_{max} ねじ部長さ b_{max}	18	20	22	24	28	32	36

FIGURE ZZD MECHANICAL STANDARD PARTS (NUTS)

3. Nuts ナット

How to read Parts Numbers
部品番号の見方

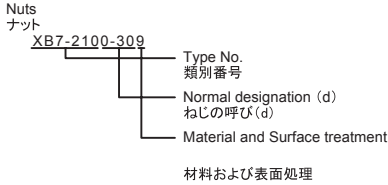

XB7-210 expresses Hexagon nut class 1.
XB7-210は、六角ナット1種を表す

0-30 expresses M3.0.
0-30は、M3.0を表す

9 expresses Steel (Black zinc trivalent chromate
treating) from Table 1.

9は、表1より鋼(黒色亜鉛3価クロメート)を表す

3-1. Hexagon Nuts and Hexagon Thin Nuts 六角ナット

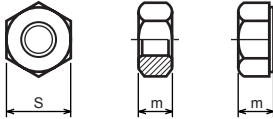

Type No. 類別番号	Type 類別
XB7-210	Hexagon nut Class 1 六角ナット-1種
XB7-220	Hexagon nut Class 3 六角ナット-3種
XB7-230	Hexagon nut Style 1 double chamfered 六角ナット-スタイル1-両面とり
XB7-231	Hexagon nut Style 1 washer faced 六角ナット-スタイル1-座付き
XB7-240	Hexagon nut Style 2 double chamfered 六角ナット-スタイル2-両面とり
XB7-241	Hexagon nut Style 2 washer faced 六角ナット-スタイル2-座付き
XB7-250	Hexagon nut 六角ナット
XB7-260	Hexagon thin nut double chamfered 六角低ナット-両面とり
XB7-270	Hexagon thin nut not chamfered 六角低ナット-面とり無し

	Head size (mm) 頭部寸法 (mm)						
	M2	M2.5	M3	M4	M5	M6	M8
S	4	5	5.5	7	8	10	13
m XB7-210	1.6	2	2.4	3.2	4	5	6.5
m XB7-220	1.2	1.6	1.8	2.4	3.2	3.6	5
m XB7-230, 231	1.6	2	2.4	3.2	4.7	5.2	6.8
m XB7-240, 241	-	-	-	-	5.1	5.7	7.5
m XB7-250	-	-	-	-	5.6	6.1	7.9
m XB7-260	1.2	1.6	1.8	2.2	2.7	3.2	4
m XB7-270	1.2	1.6	1.8	2.2	2.7	3.2	4

FIGURE ZZE MECHANICAL STANDARD PARTS (RETAINING RINGS)

5. Retaining Rings

止め輪

How to read Parts Numbers
部品番号の見方

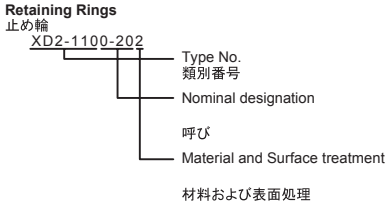

XD2-110 expresses retaining ring-E type (Type1).
XD2-110は、E形止め輪(1種)を表す

0-20 expresses a 020 of nominal designation.
(See Table 5)

0-20は、呼び020を表す(表5参照)

2 expresses Stainless steel (Surface treatment is not to be given) from Table 1.
2は、表1よりステンレス(表面処理なし)を表す

5-1. Retaining Rings - E type

E形止め輪

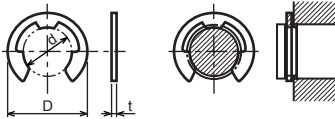

Type No. 類別番号	Type 類別
XD2-110	Retaining ring - E type (Type 1) E形止め輪(1種)
XD2-120	Retaining ring - E type (Type 2) E形止め輪(2種)

Table 5 表5

Type 種類	Nominal designation 呼び	d (mm)	D (mm)	t (mm)
Type 1 1種	007	0.65	2	0.2
	010	0.95	2.8	0.2
	013	1.25	3.3	0.3
	017	1.65	4.2	0.4
	020	1.95	4.6	0.5
	024	2.35	6	0.6
	028	2.74	6.5	0.6
	032	3.14	7.2	0.6
	037	3.64	8	0.7
	040	3.93	10	0.7
	042	4.13	10	0.7
	050	4.93	11	0.7
	058	5.73	12	0.7
	060	5.93	12.7	0.9
	064	6.32	13.5	0.9
	074	7.31	15	0.9
080	7.91	16.5	1	
Type 2 2種	008	0.8	2	0.2
	012	1.2	3	0.3
	015	1.5	4	0.4
	020	2	5	0.4
	025	2.5	6	0.4
	030	3	7	0.6
	040	4	9	0.6
	050	5	11	0.6
	060	6	12	0.8
	070	7	14	0.8
	080	8	16	0.8
	090	9	18	0.8
	100	10	20	1

5-2. Grip Rings
グリップ止め輪

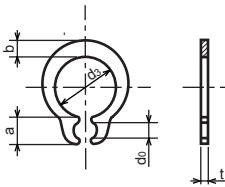

Type No. 類別番号	Type 類別
XD2-210	Grip ring グリップ止め輪

Table 5 表5

Nominal designation 呼び	d ₃ (mm)	t (mm)	b (mm)	a (mm)	d ₀ (mm)
020	1.9	0.5	1	1.8	0.8
025	2.35	0.5	1.2	1.9	0.9
030	2.85	0.6	1.4	1.9	0.9
035	3.3	0.6	1.6	2	0.9
040	3.8	0.8	1.8	2.8	1.2
045	4.25	0.8	2	2.9	1.3
050	4.75	0.8	2.2	2.9	1.3
060	5.7	1	2.4	3.1	1.4
070	6.7	1	2.7	3.3	1.4
080	7.7	1	3	3.5	1.4
090	8.65	1.2	3.3	4.7	1.5
100	9.65	1.2	3.5	4.7	2

5-3. Toothed Retaining Rings
歯付き形止め輪

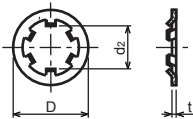

Type No. 類別番号	Type 類別
XD2-230	Toothed retaining ring 歯付き形止め輪

Table 5 表5

Nominal designation 呼び	d _z (mm)	D (mm)	t (mm)	No of teeth 歯数
015	1.4	5.2	0.25	3
020	1.9	6	0.25	3
024	2.3	6.4	0.25	3
030	2.8	8	0.25	4
040	3.8	9	0.25	4
050	4.8	10	0.25	5
060	5.8	11	0.25	5
080	7.8	13	0.25	5
100	9.8	15.4	0.25	6

5-4. Retaining Rings - C Type

C形止め輪

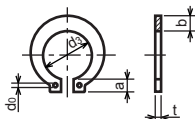

Type No. 類別番号	Type 類別
XD2-310	Retaining ring - C type for shaft C形止め輪 軸用

Table 5 表5

Nominal designation 呼び	d ₃ (mm)	t (mm)	b (mm)	a (mm)	d ₀ (mm)
010	9.3	1	1.6	3	1.2
012	11.1	1	1.8	3.2	1.5
014	12.9	1	2	3.4	1.7
015	13.8	1	2.1	3.5	1.7
016	14.7	1	2.2	3.6	1.7
017	15.7	1	2.2	3.7	1.7
018	16.5	1.2	2.6	3.8	1.7
020	18.5	1.2	2.7	3.9	2
022	20.5	1.2	2.7	4.1	2
025	23.2	1.2	3.1	4.3	2
028	25.9	1.5	3.1	4.6	2
030	27.9	1.5	3.5	4.8	2
032	29.6	1.5	3.5	5	2.5
035	32.2	1.5	4	5.4	2.5

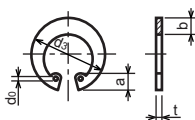

Type No. 類別番号	Type 類別
XD2-320	Retaining ring - C type for hole C形止め輪 穴用

Table 5 表5

Nominal designation 呼び	d ₃ (mm)	t (mm)	b (mm)	a (mm)	d ₀ (mm)
010	10.7	1	1.8	3.1	1.2
011	11.8	1	1.8	3.2	1.2
012	13	1	1.8	3.3	1.5
014	15.1	1	2	3.6	1.7
016	17.3	1	2	3.7	1.7
018	19.5	1	2.5	4	1.7
019	20.5	1	2.5	4	2
020	21.5	1	2.5	4	2
022	23.5	1	2.5	4.1	2
025	26.9	1.2	3	4.4	2
028	30.1	1.2	3	4.6	2
030	32.1	1.2	3	4.7	2
032	34.4	1.2	3.5	5.2	2.5
035	37.8	1.5	3.5	5.2	2.5
037	39.8	1.5	3.5	5.2	2.5
040	43.5	1.8	4	5.7	2.5
042	45.5	1.8	4	5.8	2.5
045	48.5	1.8	4.5	5.9	2.5
047	50.5	1.8	4.5	6.1	2.5
050	54.2	2	4.5	6.5	2.5
052	56.2	2	5.1	6.5	2.5
055	59.2	2	5.1	6.5	2.5
060	64.2	2	5.1	6.8	2.5
062	66.2	2	5.5	6.9	2.5
068	72.5	2.5	6	7.4	2.5
072	76.5	2.5	6.6	7.4	2.5
075	79.5	2.5	6.6	7.8	2.5
080	85.5	2.5	7	8	2.5
085	90.5	3	7	8	3
090	95.5	3	7.6	8.3	3
095	100.5	3	8	8.5	3

Prepared by
OIP Business Support Group
CANON INC.

Canon