

# **PARTS CATALOG**

**LBP6680x/6670dn/6600**

**Canon**

**Aug 6 2014**



## **PREFACE**

This Parts Catalog contains listings of parts used

Diagrams are provided with the listings to aid the service technician in identifying clearly, the item to be ordered.

Whenever ordering parts, consult this Parts Catalog for all of the information pertaining to each item. Be sure to include, in the Parts Request, the full item description, the item part number, and the quantity.

***COPYRIGHT (C) 1999 CANON INC.***

Use of this manual should be strictly supervised to avoid disclosure of confidential information.



# Contents

## NUMERICAL INDEX

LBP6680x/6670dn/6600(Numerical Index)..... 1-1

## LBP6680x/6670dn/6600(Parts Catalog)

A1	ASSEMBLY LOCATION DIAGRAM .....	2-1
A2	OPTION PARTS CATALOG LIST .....	2-2
001	ACCESSORIES .....	2-3
100	EXTERNAL COVERS, PANELS, ETC. ....	2-5
101	INTERNAL COMPONENTS 1 .....	2-8
102	INTERNAL COMPONENTS 2 .....	2-10
103	INTERNAL COMPONENTS 3 .....	2-12
104	INTERNAL COMPONENTS 4 .....	2-14
105	INTERNAL COMPONENTS 5 .....	2-16
900	MAIN CONTROLLER PCB ASS'Y .....	2-18
901	ENGINE CONTROLLER ASS'Y .....	2-19
ZZA	MECHANICAL STANDARD PARTS (HOW TO USE) .....	2-20
ZZB	MECHANICAL STANDARD PARTS (SCREWS) .....	2-21
ZZC	MECHANICAL STANDARD PARTS (BOLTS) .....	2-28
ZZD	MECHANICAL STANDARD PARTS (NUTS) .....	2-29
ZZE	MECHANICAL STANDARD PARTS (RETAINING RINGS) .....	2-30



# NUMERICAL INDEX

## LBP6680x/6670dn/6600(Numerical Index)

PARTS NUMBER	FIGURE & KEY NO.	PARTS NUMBER	FIGURE & KEY NO.	PARTS NUMBER	FIGURE & KEY NO.
FC0-4235-000	100 - 1	FM4-8674-000	100 - 20	RU6-0688-000	101 - 12
FC0-4236-000	100 - 2	FM4-8677-000	100 - 9	RU6-0690-000	101 - 13
FC0-4239-000	100 - 5	FM4-8678-000	100 - 9	RU6-0693-000	101 - 14
FC0-4241-000	100 - 5	FM4-8679-000	100 - 9	RU6-2610-000	101 - 10
FC0-4251-000	100 - 7	FM4-8680-000	100 - 9	WC4-5171-000	104 - 10
FC0-4252-000	100 - 4	FM4-8681-000	100 - 9	XA9-1420-000	103 - 7
FC0-4268-000	100 - 21	FM4-8682-000	100 - 9	XA9-1420-000	105 - 8
FC0-4269-000	100 - 19	FM4-8683-000	100 - 10	XA9-1503-000	100 - 18
FC0-4270-000	100 - 16	NPN	001 -	XA9-1503-000	101 - 5
FC0-4275-000	100 - 19	NPN	100 -	XA9-1503-000	105 - 5
FC0-4281-000	100 - 15	NPN	101 -	XA9-1671-000	100 - 17
FC0-4282-000	100 - 2	NPN	102 -	XA9-1671-000	101 - 6
FC0-4283-000	100 - 2	NPN	103 -	XA9-1671-000	102 - 7
FC0-4285-000	100 - 2	NPN	104 -	XA9-1671-000	103 - 8
FC0-4287-000	100 - 2	NPN	105 -	XA9-1671-000	104 - 11
FC0-4309-000	105 - 1	RC2-6130-000	102 - 8	XA9-1671-000	105 - 6
FC7-9850-000	104 - 12	RC2-6136-000	104 - 15		
FC8-9837-000	100 - 3	RC2-6198-000	101 - 11		
FC8-9896-000	100 - 6	RC2-6273-000	100 - 11		
FC8-9985-000	100 - 14	RC2-8291-000	100 - 12		
FH2-7080-000	001 - 4	RC2-8349-000	101 - 7		
FH2-7082-000	001 - 5	RK2-0549-000	901 - IC		
FK2-1316-000	001 - 6	RK2-0550-000	901 - IC		
FK2-4390-000	001 - 2	RK2-1302-000	001 - 7		
FK2-9583-000	001 - 3	RK2-2728-000	104 - 4		
FK3-1986-000	104 - 14	RK2-2729-000	104 - 5		
FK3-2710-000	105 - 9	RK2-2731-000	104 - 6		
FK3-3059-000	001 - 1	RK2-2733-000	105 - 2		
FK3-3060-000	001 - 1	RK2-3708-000	103 - 4		
FK3-3061-000	001 - 1	RL1-2111-000	101 - 9		
FK3-3063-000	001 - 1	RL1-2112-000	101 - 8		
FK3-3066-000	001 - 1	RL1-2115-000	102 - 1		
FK3-3068-000	001 - 1	RL1-2120-000	104 - 7		
FK4-0723-000	001 - 1	RM1-1301-000	102 - 2		
FK4-1276-000	105 - 10	RM1-4275-020	104 - 8		
FM0-0908-010	900 -	RM1-6350-000	102 - 3		
FM0-1136-000	901 -	RM1-6378-000	102 - 5		
FM0-1137-000	901 -	RM1-6397-000	104 - 9		
FM0-1138-000	105 - 7	RM1-6401-000	101 - 2		
FM0-1139-000	104 - 13	RM1-6402-000	103 - 5		
FM0-1140-000	104 - 2	RM1-6405-000	101 - 1		
FM0-1141-000	102 - 4	RM1-6406-000	101 - 1		
FM0-1296-010	900 -	RM1-6414-000	102 - 6		
FM0-1297-010	900 -	RM1-6419-000	103 - 6		
FM0-4723-000	104 - 1	RM1-6421-000	101 - 3		
FM1-D112-000	101 - 1	RM1-6423-000	105 - 3		
FM1-E133-000	100 - 9	RM1-6424-000	103 - 2		
FM1-E134-000	100 - 9	RM1-6441-000	105 - 4		
FM1-G859-000	901 -	RM1-6445-000	101 - 4		
FM3-9088-000	101 - 1	RM1-6450-000	103 - 3		
FM4-8671-000	100 - 8	RU5-2895-000	100 - 13		
FM4-8672-000	103 - 1	RU6-0674-000	101 - 15		





# **LBP6680x/6670dn/6600(Parts Catalog)**

## **Satera LBP6600**

<b>100V JP</b>	<b>F16-1912-000</b>	<b>MKPA</b>
----------------	---------------------	-------------

## **i-SENSYS LBP6680x**

<b>230V EUR</b>	<b>F16-1991-000</b>	<b>-MKQA879999</b>
-----------------	---------------------	--------------------

<b>230V EUR</b>	<b>F16-1993-000</b>	<b>MKQA880000-</b>
-----------------	---------------------	--------------------

## **i-SENSYS LBP6670dn**

<b>230V EUR</b>	<b>F16-1992-000</b>	<b>-MKRA879999</b>
-----------------	---------------------	--------------------

<b>230V EUR</b>	<b>F16-1994-000</b>	<b>MKRA880000-</b>
-----------------	---------------------	--------------------

## **imageCLASS LBP6680x**

<b>230V SG,HK,KR</b>	<b>F16-1941-000</b>	<b>MKSA</b>
----------------------	---------------------	-------------

<b>230V AU</b>	<b>F16-1941-000</b>	<b>MKYA</b>
----------------	---------------------	-------------

## **imageCLASS LBP6670dn**

<b>120V US</b>	<b>F16-1932-000</b>	<b>MLBA</b>
----------------	---------------------	-------------

<b>230V CN</b>	<b>F16-1952-000</b>	<b>MKXA</b>
----------------	---------------------	-------------



# Contents

A1	ASSEMBLY LOCATION DIAGRAM .....	2-1
A2	OPTION PARTS CATALOG LIST .....	2-2
001	ACCESSORIES .....	2-3
100	EXTERNAL COVERS, PANELS, ETC. ....	2-5
101	INTERNAL COMPONENTS 1 .....	2-8
102	INTERNAL COMPONENTS 2 .....	2-10
103	INTERNAL COMPONENTS 3 .....	2-12
104	INTERNAL COMPONENTS 4 .....	2-14
105	INTERNAL COMPONENTS 5 .....	2-16
900	MAIN CONTROLLER PCB ASS'Y .....	2-18
901	ENGINE CONTROLLER ASS'Y .....	2-19
ZZA	MECHANICAL STANDARD PARTS (HOW TO USE) .....	2-20
ZZB	MECHANICAL STANDARD PARTS (SCREWS).....	2-21
ZZC	MECHANICAL STANDARD PARTS (BOLTS).....	2-28
ZZD	MECHANICAL STANDARD PARTS (NUTS).....	2-29
ZZE	MECHANICAL STANDARD PARTS (RETAINING RINGS) .....	2-30



# FIGURE A1 ASSEMBLY LOCATION DIAGRAM

EXCEPT  
i-SENSYS LBP6680x MKQA880000-  
i-SENSYS LBP6670dn MKRA880000-

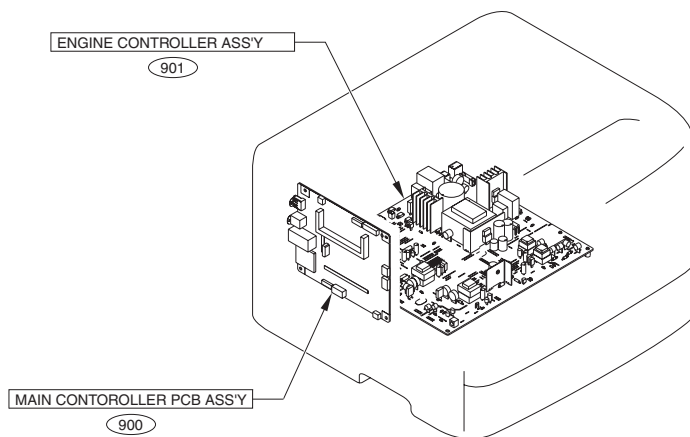

i-SENSYS LBP6680x MKQA880000-  
i-SENSYS LBP6670dn MKRA880000-

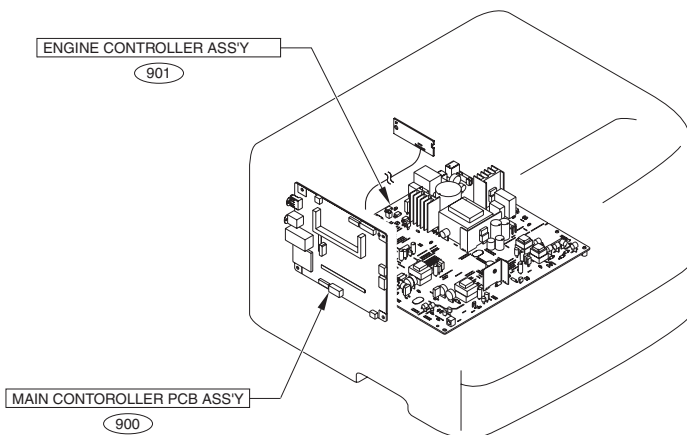

## FIGURE A2 OPTION PARTS CATALOG LIST

This is the table of the machine's options whose parts catalog is issued.  
本機のオプションで、パーツカタログが発行されている機種の一覧である。

No.	Model Name(English)	Model Name(Japanese)
1	Paper Feeder Unit PF-44	ペーパーフィーダーユニット PF-44

# FIGURE 001 ACCESSORIES

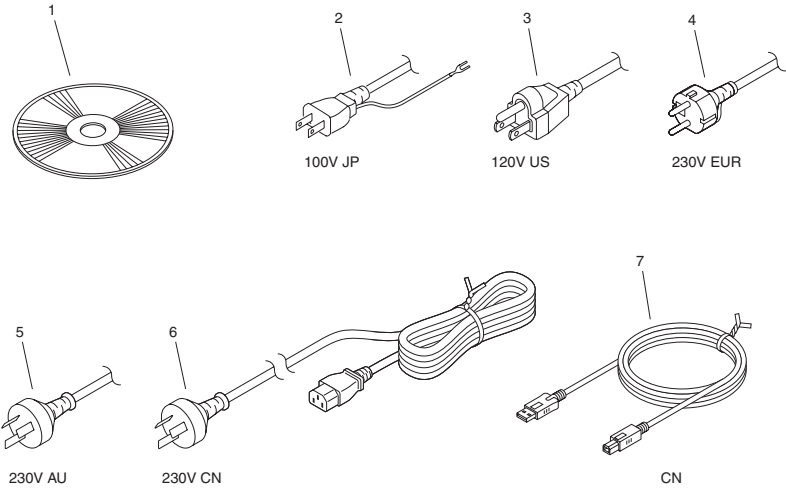

FIGURE & KEY NO.	PARTS NUMBER	RANK	Q'TY	DESCRIPTION	SERIAL NUMBER/REMARKS	SVC
Fig.001	NPN		RF	ACCESSORIES		
1	FK3-3059-000		1	CD-ROM, PRINTER DRIVER	Satera LBP6600 LIPSLX Japanese	
1	FK3-3060-000		1	CD-ROM, PRINTER DRIVER	i-SENSYS LBP6680x PCL/ UFR II English, French, Italian, Ger man, Spanish	
1	FK3-3061-000		1	CD-ROM, PRINTER DRIVER	imageCLASS LBP6680x i- SENSYS LBP6680x PS UK English, French, Italian, Ger man, Spanish, Simplified Chinese, Korean	
1	FK3-3063-000		1	CD-ROM, PRINTER DRIVER	imageCLASS LBP6680x PCL/UFR II UK English, Spanish, Simplified Chinese, Korean	
1	FK4-0723-000		1	CD-ROM, PRINTER DRIVER	imageCLASS LBP6670dn PS/PCL/UFR II US English, Spanish	

FIGURE & KEY NO.	PARTS NUMBER	RANK	Q'TY	DESCRIPTION	SERIAL NUMBER/REMARKS	SVC
1	FK3-3066-000		1	CD-ROM, PRINTER DRIVER	i-SENSYS LBP6670dn PCL/UFRII English,French,Italian,German,Spanish	
1	FK3-3068-000		1	CD-ROM, PRINTER DRIVER	imageCLASS LBP6670dn PCL/UFRII UK English,Spanish,Simplified Chinese,Korean	
2	FK2-4390-000		1	CORD, POWER	100V JP	
3	FK2-9583-000		1	CORD, POWER	120V US	
4	FH2-7080-000		1	CORD, POWER	230V EUR	
5	FH2-7082-000		1	CORD, POWER	230V AU	
6	FK2-1316-000		1	CORD, POWER	230V CN	
7	RK2-1302-000		1	CABLE, USB HOST POWER SUPPLY	CN	



# FIGURE 100 EXTERNAL COVERS, PANELS, ETC.

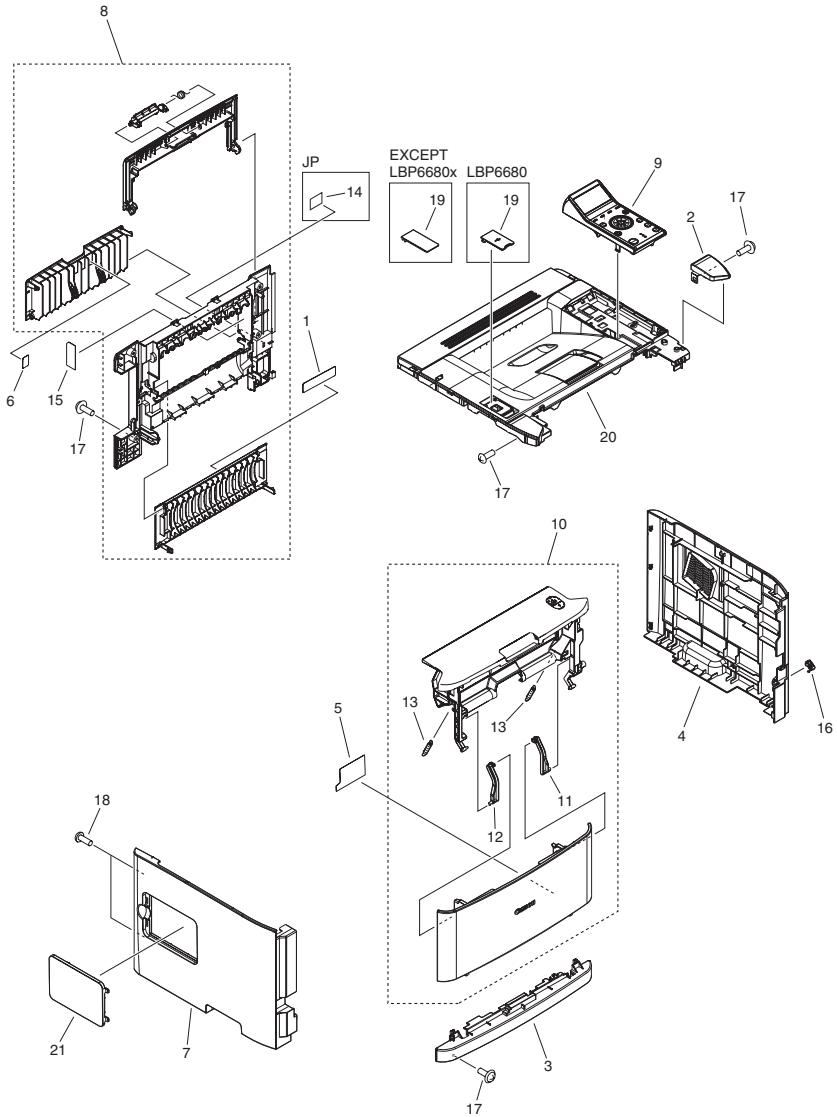

FIGURE & KEY NO.	PARTS NUMBER	R A N K	Q'TY	DESCRIPTION	SERIAL NUMBER/ REMARKS	S V C
Fig.100	NPN		RF	EXTERNAL COVERS, PANELS, ETC.		
1	FC0-4235-000		1	LABEL, DUPLEXING SIZE CONTROL		
2	FC0-4236-000		1	COVER, RIGHT, UPPER	LBP6600	
2	FC0-4282-000		1	COVER, RIGHT, UPPER	i-SENSYS LBP6680x	
2	FC0-4283-000		1	COVER, RIGHT, UPPER	i-SENSYS LBP6670dn	
2	FC0-4285-000		1	COVER, RIGHT, UPPER	imageCLASS LBP6670dn	
2	FC0-4287-000		1	COVER, RIGHT, UPPER	imageCLASS LBP6680x	
3	FC8-9837-000		1	COVER, FRONT		
4	FC0-4252-000		1	COVER, RIGHT		
5	FC0-4239-000		1	LABEL, MP, SIZE	EXCEPT JP	
5	FC0-4241-000		1	LABEL, MP, SIZE	JP	
6	FC8-9896-000		1	LABEL, ATTENTION		
7	FC0-4251-000		1	COVER, LEFT		
8	FM4-8671-000		1	REAR COVER ASS'Y		
9	FM4-8677-000		1	OPERATION PANEL ASS'Y	i-SENSYS LBP6680x - MKQA879999	
9	FM4-8678-000		1	OPERATION PANEL ASS'Y	imageCLASS LBP6680x	
9	FM4-8679-000		1	OPERATION PANEL ASS'Y	Satera LBP6600	
9	FM4-8680-000		1	OPERATION PANEL ASS'Y	i-SENSYS LBP6670dn - MKRA879999	
9	FM4-8681-000		1	OPERATION PANEL ASS'Y	imageCLASS LBP6670dn US	
9	FM4-8682-000		1	OPERATION PANEL ASS'Y	imageCLASS LBP6670dn CN	
9	FM1-E133-000		1	OPERATION PANEL ASS'Y	i-SENSYS LBP6680x MKQA880000-	
9	FM1-E134-000		1	OPERATION PANEL ASS'Y	i-SENSYS LBP6670dn MKRA880000-	
10	FM4-8683-000		1	CARTRIDGE DOOR ASS'Y		
11	RC2-6273-000		1	HINGE, MULTI-PURPOSE, RIGHT		
12	RC2-8291-000		1	HINGE, MULTI-PURPOSE, LEFT		
13	RU5-2895-000		2	SPRING, TENSION		
14	FC8-9985-000		1	LABEL, GROUNDING CAUTION	JP	
15	FC0-4281-000		1	LABEL, CAUTION		
16	FC0-4270-000		1	COVER, SWITCH		

FIGURE & KEY NO.	PARTS NUMBER	RANK	Q'TY	DESCRIPTION	SERIAL NUMBER/REMARKS	SVC
17	XA9-1671-000		AR	SCREW, D, M3X8		
18	XA9-1503-000		2	SCREW, TAP, M3X6		
19	FC0-4275-000		1	COVER, USB	EXCEPT LBP6680x	
19	FC0-4269-000		1	COVER, USB	LBP6680x	
20	FM4-8674-000		1	TOP COVER ASS'Y		
21	FC0-4268-000		1	COVER, DIMM		

FIGURE 101  
INTERNAL COMPONENTS 1

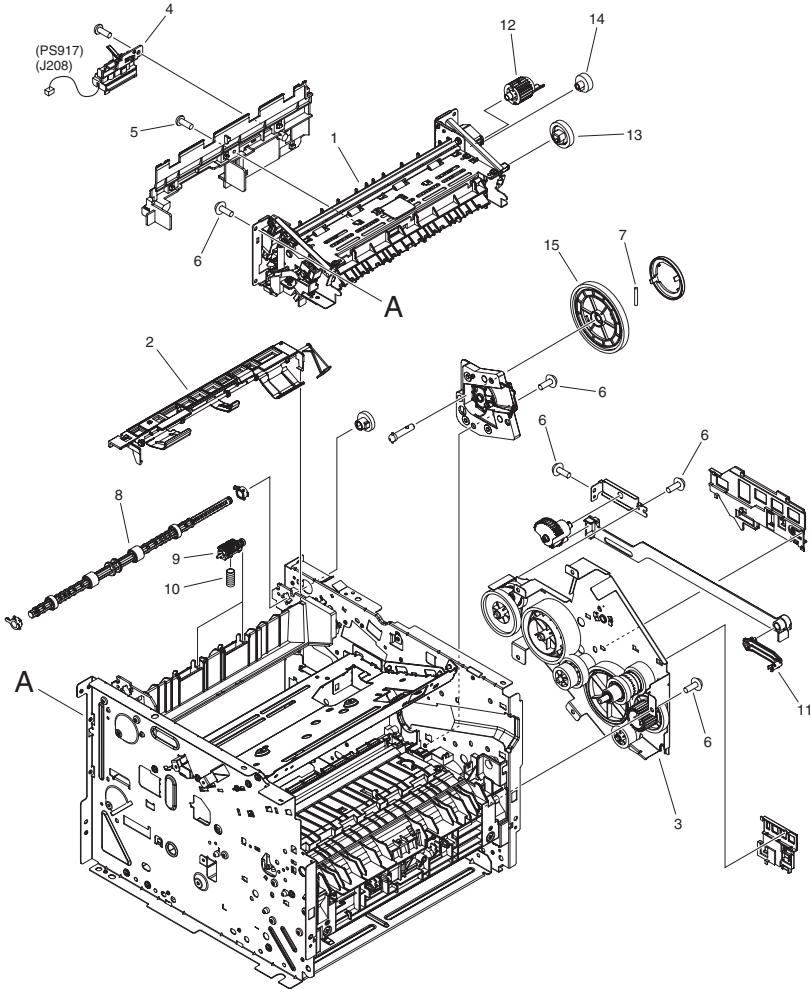

FIGURE & KEY NO.	PARTS NUMBER	R A N K	Q'TY	DESCRIPTION	SERIAL NUMBER/ REMARKS	S V C
Fig.101	NPN		RF	INTERNAL COMPONENTS 1		
1	FM3-9088-000		1	FIXING ASS'Y	100V	
1	RM1-6405-000		1	FIXING ASS'Y	120V	
1	RM1-6406-000		1	FIXING ASS'Y	230V EXCEPT i-SENSYS LBP6680x MKQA880000- i-SENSYS LBP6670dn MKRA880000-	
1	FM1-D112-000		1	FIXING ASS'Y	230V i-SENSYS LBP6680x MKQA880000- i-SENSYS LBP6670dn MKRA880000-	
2	RM1-6401-000		1	PAPER RETAINING DELIVERY ASS'Y		
3	RM1-6421-000		1	MAIN DRIVE ASS'Y		
4	RM1-6445-000		1	REVERSE SENSOR ASS'Y	PS917	
5	XA9-1503-000		3	SCREW, TAP, M3X6		
6	XA9-1671-000		AR	SCREW, D, M3X8		
7	RC2-8349-000		1	PIN LARGE GEAR		
8	RL1-2112-000		1	ROLLER, FACE-DOWN		
9	RL1-2111-000		2	FACE-DOWN ROLLER UNIT		
10	RU6-2610-000		2	SPRING, COMPRESSION		
11	RC2-6198-000		1	ARM, LINK, 1		
12	RU6-0688-000		1	GEAR, 21T		
13	RU6-0690-000		1	GEAR, 27T		
14	RU6-0693-000		1	GEAR, 17T		
15	RU6-0674-000		1	GEAR, 145T		

# FIGURE 102 INTERNAL COMPONENTS 2

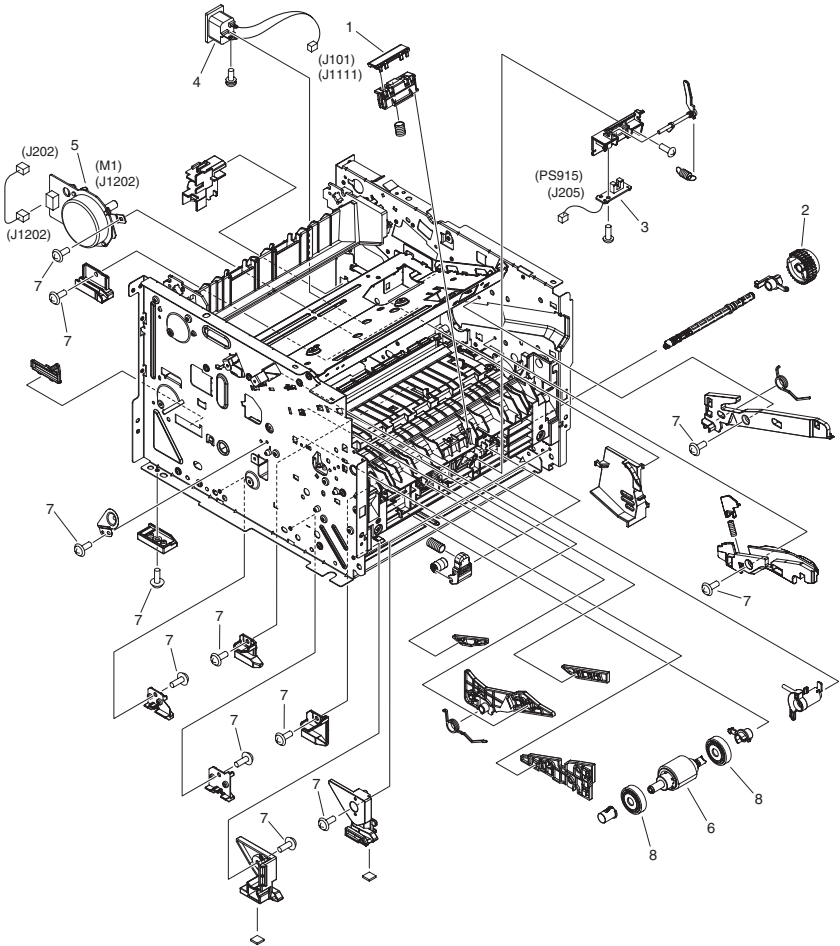

FIGURE & KEY NO.	PARTS NUMBER	RANK	Q'TY	DESCRIPTION	SERIAL NUMBER/REMARKS	SVC
Fig.102	NPN		RF	INTERNAL COMPONENTS 2		
1	RL1-2115-000		1	PAD, MULTI-PURPOSE SEPARATION		
2	RM1-1301-000		1	PAPER PICK-UP GEAR ASS'Y		
3	RM1-6350-000		1	MULTI-PURPOSE SENSOR PCB ASS'Y	PS915	
4	FM0-1141-000		1	INLET AC RELAY CABLE		
5	RM1-6378-000		1	MAIN MOTOR ASS'Y	M1	
6	RM1-6414-000		1	PAPER PICK-UP ROLLER ASS'Y		
7	XA9-1671-000		AR	SCREW, D, M3X8		
8	RC2-6130-000		2	ROLLER, CASSETTE PAPER PICK-UP		

# FIGURE 103 INTERNAL COMPONENTS 3

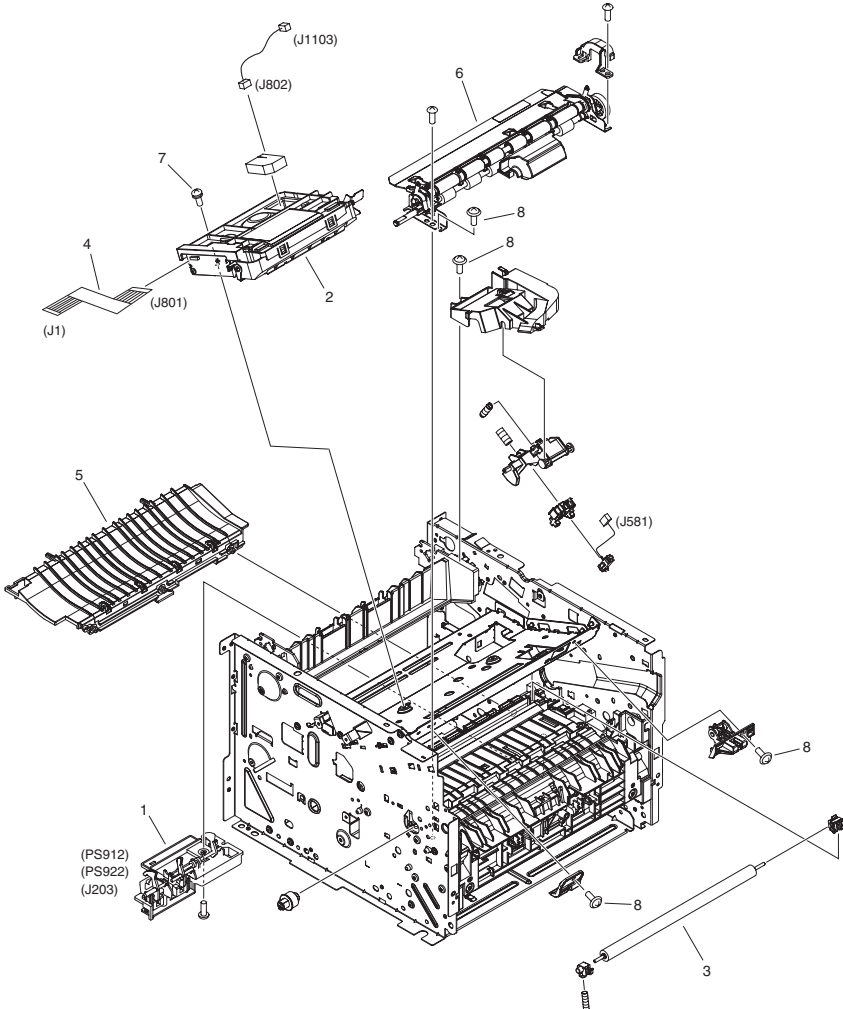



FIGURE & KEY NO.	PARTS NUMBER	RANK	Q'TY	DESCRIPTION	SERIAL NUMBER/REMARKS	SVC
Fig.103	NPN		RF	INTERNAL COMPONENTS 3		
1	FM4-8672-000		1	TOP SENSOR ASS'Y	PS912,PS922	
2	RM1-6424-000		1	SCANNER ASS'Y		
3	RM1-6450-000		1	TRANSFER ROLLER ASS'Y		
4	RK2-3708-000		1	CABLE, LASER FLEXIBLE FLAT		
5	RM1-6402-000		1	PAPER FEED GUIDE ASS'Y		
6	RM1-6419-000		1	REGISTRATION ASS'Y		
7	XA9-1420-000		4	SCREW, WWASHER, M3X8		
8	XA9-1671-000		5	SCREW, D, M3X8		

# FIGURE 104 INTERNAL COMPONENTS 4

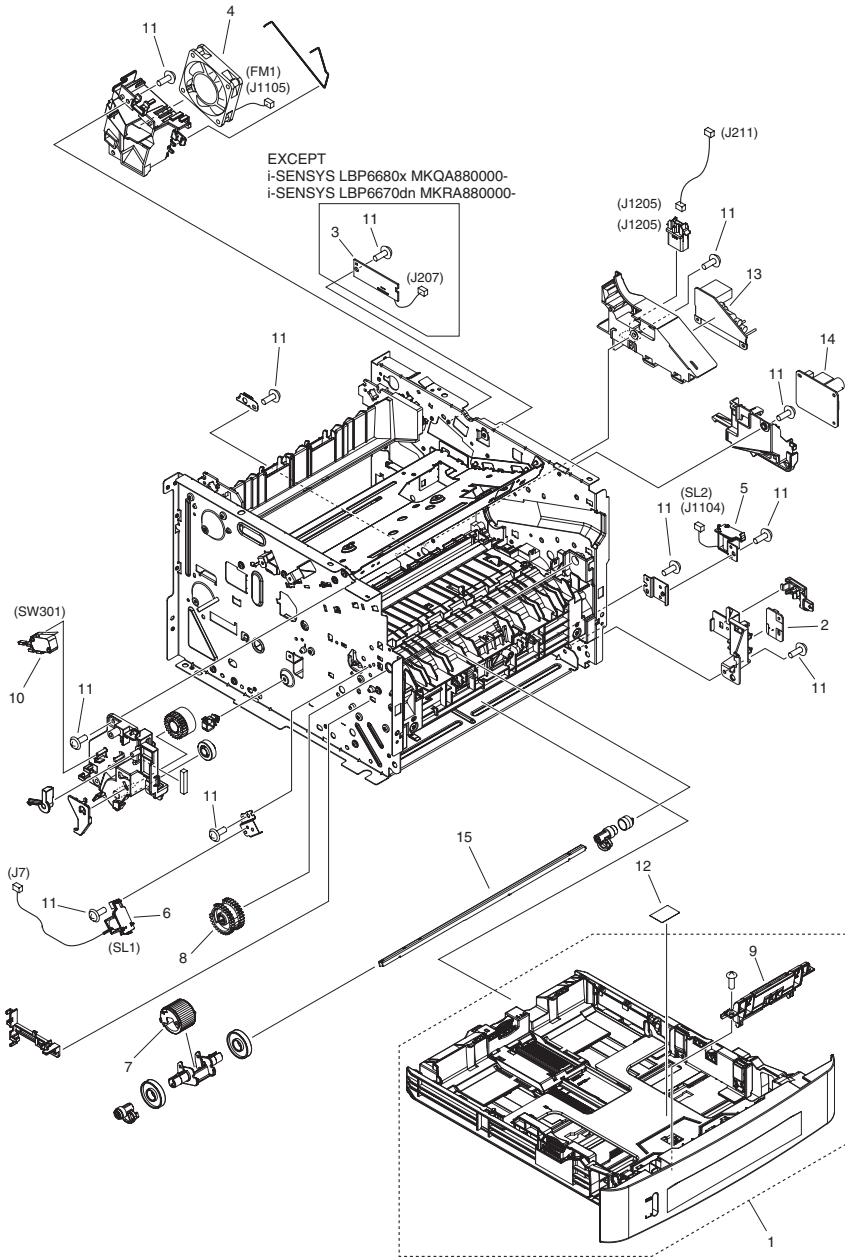

FIGURE & KEY NO.	PARTS NUMBER	R A N K	Q'TY	DESCRIPTION	SERIAL NUMBER/ REMARKS	S V C
Fig.104	NPN		RF	INTERNAL COMPONENTS 4		
1	FM0-4723-000		1	CASSETTE ASS'Y		
2	FM0-1140-000		1	POWER SWITCH PCB ASS'Y		
4	RK2-2728-000		1	FAN	FM1	
5	RK2-2729-000		1	SOLENOID	SL2	
6	RK2-2731-000		1	SOLENOID	SL1	
7	RL1-2120-000		1	ROLLER, MULTI-PURPOSE PICK-UP		
8	RM1-4275-020		1	PAPER PICK-UP GEAR ASS'Y		
9	RM1-6397-000		1	SEPARATION PAD HOLDER ASS'Y		
10	WC4-5171-000		1	MICROSWITCH	SW301	
11	XA9-1671-000		AR	SCREW, D, M3X8		
12	FC7-9850-000		1	LABEL, PROHIBITION DOCUMENT		
13	FM0-1139-000		1	AC RELAY ASS'Y		
14	FK3-1986-000		1	EVERYNIGHT POWER PCB ASSEMBLY		
15	RC2-6136-000		1	SHAFT, PAPER PICK-UP		



FIGURE & KEY NO.	PARTS NUMBER	RANK	Q'TY	DESCRIPTION	SERIAL NUMBER/REMARKS	SVC
Fig.105	NPN		1	INTERNAL COMPONENTS 5		
1	FC0-4309-000		1	COVER, SD CARD		
2	RK2-2733-000		1	SOLENOID	SL3	
3	RM1-6423-000		1	REVERSE DRIVE ASS'Y		
4	RM1-6441-000		1	DUPLEXING PAPER FEED ASS'Y		
5	XA9-1503-000		AR	SCREW, TAP, M3X6		
6	XA9-1671-000		6	SCREW, D, M3X8		
7	FM0-1138-000		1	SLEEP IF ASS'Y		
8	XA9-1420-000		4	SCREW, W/WASHER, M3X8		
9	FK3-2710-000		1	CABLE USB	LBP6680x	
10	FK4-1276-000		1	DIMM, SMD-E25646H2P-6E, SDRAM	LBP6670dn	

# FIGURE 900 MAIN CONTROLLER PCB ASS'Y

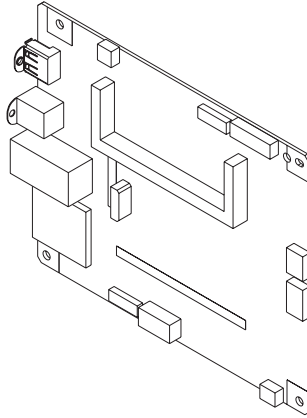
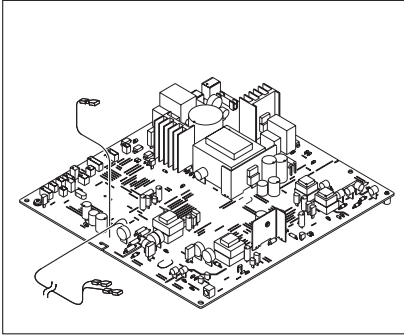

FIGURE & KEY NO.	PARTS NUMBER	RANK	QTY	DESCRIPTION	SERIAL NUMBER/REMARKS	SVC
Fig.900	FM0-1296-010		1	MAIN CONTROLLER PCB ASSEMBLY	LBP6680x	
Fig.900	FM0-1297-010		1	MAIN CONTROLLER PCB ASSEMBLY	LBP6670dn	
Fig.900	FM0-0908-010		1	MAIN CONTROLLER PCB ASSEMBLY	LBP6600	

# FIGURE 901 ENGINE CONTROLLER ASS'Y

100V,120V  
EXCEPT 230V EUR



230V EUR

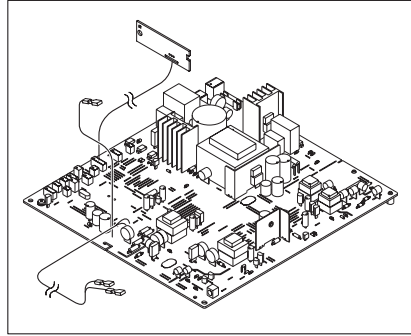

FIGURE & KEY NO.	PARTS NUMBER	RANK	Q'TY	DESCRIPTION	SERIAL NUMBER/REMARKS	SVC
Fig.901	FM0-1136-000		1	ENGINE CONTROLLER ASS'Y	100V,120V	
Fig.901	FM0-1137-000		1	ENGINE CONTROLLER ASS'Y	EXCEPT 230V EUR	
Fig.901	FM1-G859-000		1	ENGINE CONTROLLER PCB ASS'Y	230V EUR	
IC	RK2-0549-000		1	IC, STR-W6735C RP, REGULATOR	100V,120V	
IC	RK2-0550-000		1	IC, STR-W6765C RP, REGULATOR	230V	

# FIGURE ZZA

## MECHANICAL STANDARD PARTS (HOW TO USE)

### Mechanical standard parts

#### 機械標準部品

#### About a mechanical standard parts

A Mechanical standard parts is a mechanical part which not parts peculiar to a product. They are parts which are common to a Canon product and are used, such as a screw and a washer. The Fig No. and parts number of the mechanical standard parts are not listed in the product parts catalog. Refer to the parts catalog of mechanical standard parts when checking the parts number for screw or washer etc. and identify them by part shape or size.

#### 機械標準部品とは

機械標準部品とは、製品特有の部品ではなく、ねじやワッシャなどキヤノン製品共通で使用されている機械部品（メカ部品）のことです。  
製品のパーツカタログには、機械標準部品のFig No.や部品番号は記載しておりません。  
ねじや、ワッシャ等の部品番号を調べるときは、機械標準部品のパーツカタログを参照し、部品の形状や大きさから判断し、使用している部品を調べてください。

#### Material and surface treatment of a mechanical standard parts

Material and surface treatment of mechanical standard parts are assigned commonly for each part. Refer to the Table 1 for the parts which material and surface treatment are assigned as numbers.

#### 機械標準部品の材料および表面処理

機械標準部品の材料および表面処理については、各種部品共通で決められています。  
材料および表面処理が番号で決められている部品については、表1を参照してください。

Table 1 Material and Surface treatment

表1 材料および表面処理

No. 番号	Material 材料	Surface treatment 表面処理	Color 色
1	Stainless steel ステンレス	Stainless steel black coloring (BC4) ステンレス黒着色(BC4)	Black 黒
2		not to be given なし	White 白
3	Brass 黄銅	Regular nickel plating (NL) 普通ニッケルメッキ(NL)	White 白
4		Black nickel plating (BN) 黒色ニッケルメッキ(BN)	Black 黒
5	Steel 鋼	White zinc trivalent chromate treating (ZC3) 白色亜鉛3価クロメート(ZC3)	White 白
6		Regular nickel chromium plating (NC) 普通ニッケルクロムメッキ(NC)	White 白
7		Regular nickel plating (NL) 普通ニッケルメッキ(NL)	White 白
8		Iron and steel phosphating (P1) 鉄鋼磷酸塩処理(P1)	Black 黒
9		Black zinc trivalent chromate treating (BZ3) 黒色亜鉛3価クロメート(BZ3)	Black 黒



# FIGURE ZZB MECHANICAL STANDARD PARTS (SCREWS)

## 1. Screws ねじ

How to read Parts Numbers  
部品番号の見方

Screws  
ねじ

XB1-2400-609

Type No.  
類別番号

Normal designation (d)  
ねじの呼び(d)

Length (L)  
ねじの長さ(L)

Material and Surface treatment  
材料および表面処理

XB1-2 expresses Binding head machine screw.  
XB1-2は、バインドねじを表す

40 expresses M4.0.  
40は、M4.0を表す

0-60 expresses a length of 6.0mm.  
0-60は、6.0mmの長さを表す

9 expresses Steel (Black zinc trivalent chromate  
treating) from Table 1.

9は、表1より鋼(黒色亜鉛3価クロメート)を表す

### 1-1. Cross Recessed Head Screws for Precision Equipments

精密機器用十字穴付き小ねじ

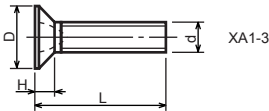
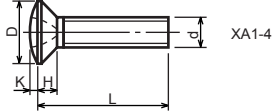
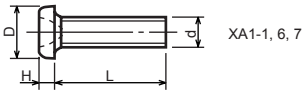

Type No. 類別番号	Type 類別
XA1-1	Pan head Class 1 なべ1種
XA1-3	Countersunk head Class 1 さら1種
XA1-4	Oval countersunk head Class 1 丸さら1種
XA1-6	Pan head Class 3 なべ3種
XA1-7	Pan head Class 2 なべ2種

		Head size (mm) 頭部寸法 (mm)					
		M1.4	M1.6	M1.7	M2	M2.5	M2.6
D	XA1-1	2	2.4	2.5	3	3.8	4
H	XA1-1	0.5	0.55	0.5	0.6	0.9	0.8
D	XA1-3	2	2.4	2.5	3	3.8	4
H	XA1-3	0.48	0.55	0.58	0.73	0.85	0.93
D	XA1-4	2	2.4	2.5	3	3.8	4
H + K	XA1-4	0.68	0.8	0.88	1	1.25	1.3
D	XA1-6	2.5	2.8	3	3.5	4.3	4.5
H	XA1-6	0.8	0.85	0.9	1	1.3	1.2
D	XA1-7	2.5	2.8	3	3.5	4.3	4.5
H	XA1-7	0.5	0.55	0.5	0.6	0.9	0.8

**1-2. Precision Tapping Screws**  
精密用タッピンねじ

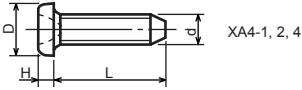

XA4-1, 2, 4

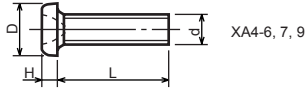

XA4-6, 7, 9

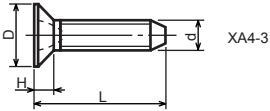

XA4-3

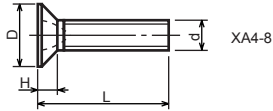

XA4-8

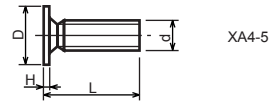

XA4-5

Type No. 類別番号	Type 類別	Head size (mm) 頭部寸法 (mm)						
		M1.4	M1.6	M1.7	M2	M2.5	M2.6	
XA4-1	With tapered end pan head Class 1 絞りなべ1種	D XA4-1	2	2.4	2.5	3	3.8	4
		H XA4-1	0.5	0.55	0.5	0.6	0.9	0.8
XA4-2	With tapered end pan head Class 3 絞りなべ3種	D XA4-2	2.5	2.8	3	3.5	4.3	4.5
		H XA4-2	0.8	0.85	0.9	1	1.3	1.2
XA4-3	With tapered end countersunk head 絞り-さら	D XA4-3	2	2.4	2.5	3	3.8	4
		H XA4-3	0.48	0.55	0.58	0.73	0.85	0.93
XA4-4	With tapered end pan head Class 2 絞りなべ2種	D XA4-4	2.5	2.8	3	3.5	4.3	4.5
		H XA4-4	0.5	0.55	0.5	0.6	0.9	0.8
XA4-5	With parallel end ultra thin head ストレート-超薄頭	D XA4-5	2.5	2.8	3	-	-	-
		H XA4-5	0.2	0.2	0.2	-	-	-
XA4-6	With parallel end pan head Class 1 ストレートなべ1種	D XA4-6	2	2.4	2.5	3	3.8	4
		H XA4-6	0.5	0.55	0.5	0.6	0.9	0.8
XA4-7	With parallel end pan head Class 3 ストレートなべ3種	D XA4-7	2.5	2.8	3	3.5	4.3	4.5
		H XA4-7	0.8	0.85	0.9	1	1.3	1.2
XA4-8	With parallel end countersunk head ストレート-さら	D XA4-8	2	2.4	2.5	3	3.8	4
		H XA4-8	0.48	0.55	0.58	0.73	0.85	0.93
XA4-9	With parallel end pan head Class 2 ストレートなべ2種	D XA4-9	2.5	2.8	3	3.5	4.3	4.5
		H XA4-9	0.5	0.55	0.5	0.6	0.9	0.8

**1-3. Cross Recessed Head Screws**  
 一般用十字穴付き小ねじ

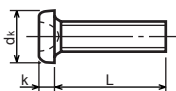

XB1-1

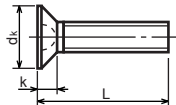

XB1-3

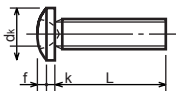

XB1-2

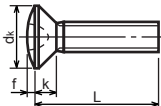

XB1-4

Type No. 類別番号	Type 類別
XB1-1	Pan head なべ
XB1-2	Binding head バインド
XB1-3	Countersunk head ざら
XB1-4	Oval countersunk head 丸ざら

		Head size (mm) 頭部寸法 (mm)					
		M2	M2.5	M2.6	M3	M4	M5
dk	XB1-1	3.5	4.5	4.5	5.5	7	9
k	XB1-1	1.3	1.7	1.7	2	2.6	3.3
dk	XB1-2	4.3	5.3	5.5	6.3	8.3	10.3
k+f	XB1-2	1.2	1.5	1.6	1.9	2.5	3.1
dk	XB1-3	4	5	-	6	8	10
k	XB1-3	1.2	1.45	-	1.75	2.3	2.8
dk	XB1-4	4	5	-	6	8	10
k+f	XB1-4	1.6	2	-	2.45	3.2	4
Screw part length ねじ部長さ b		8	12	12	12	16	20

1-4. Cross Recessed Head Screws with Captive Washer  
 座金組み込み十字穴付き小ねじ

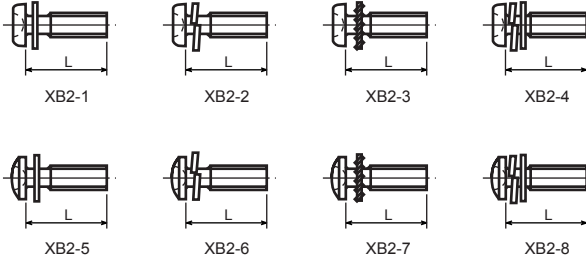

Type No. 類別番号	Type 類別
XB2-1	Pan head + Plain washer (circular bright) なべねじ+平座金
XB2-2	Pan head + Spring washer なべねじ+ばね座金
XB2-3	Pan head + Toothed lock washer なべねじ+歯付座金
XB2-4	Pan head + Spring washer and plain washer (circular bright) なべねじ+(ばね+平)座金
XB2-5	Binding head + Plain washer (circular bright) バインドねじ+平座金
XB2-6	Binding head + Spring washer バインドねじ+ばね座金
XB2-7	Binding head + Toothed lock washer バインドねじ+歯付座金
XB2-8	Binding head + Spring washer and plain washer (circular bright) バインドねじ+(ばね+平)座金

**1-5. Hexagon Head Tapping Screws for Metallic Materials**  
 金属用六角タッピンねじ

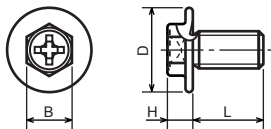

Type No. 類別番号	Type 類別	Head size (mm) 頭部寸法 (mm)	
		M3	M4
XB3-6	For metallic materials 金属用タッピン	D	8 10
		B	5.5 5.5
XB3-7	For metallic materials with clawed 金属用タッピン-つめ付き	H XB3-6	3.1 3.1
		H XB3-7	3.2 3.2

**1-6. Special Tapping Screws**  
 特殊タッピンねじ

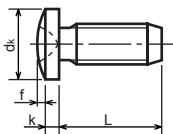

Type No. 類別番号	Type 類別	Head size (mm) 頭部寸法 (mm)	
		M3	M4
XB4-5	Binding head バインド	d <sub>k</sub>	6.3 8.3
		k	1.3 1.7
		k+f	1.9 2.5

1-7. General Head Tapping Screws  
一般用タッピンねじ

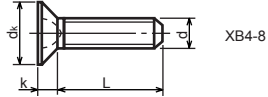
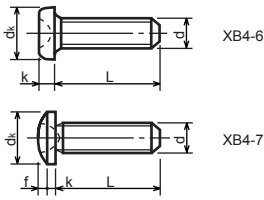

Type No. 類別番号	Type 類別	Head size (mm) 頭部寸法 (mm)						
		M2	M2.5	M2.6	M3	M4	M5	
XB4-6	Pan head なべ	$d_k$ XB4-6	3.5	4.5	4.5	5.5	7	9
		$k$ XB4-6	1.3	1.7	1.7	2	2.6	3.3
XB4-7	Binding head バインド	$d_k$ XB4-7	4.3	5.3	5.5	6.3	8.3	10.3
		$k+f$ XB4-7	1.2	1.5	1.6	1.9	2.5	3.1
XB4-8	Countersunk head さら	$d_k$ XB4-8	4	5	5.2	6	8	10
		$k$ XB4-8	1.2	1.45	1.5	1.75	2.3	2.8

1-8. Tapping Screws for Metallic Materials  
金属用タッピンねじ

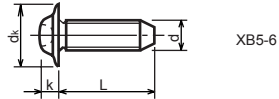
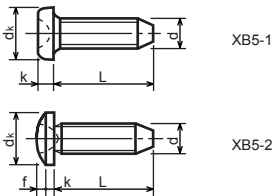

Type No. 類別番号	Type 類別	Head size (mm) 頭部寸法 (mm)					
		M2.5	M2.6	M3	M4	M5	
XB5-1	Pan head なべ	$d_k$ XB5-1	4.5	4.5	5.5	7	9
		$k$ XB5-1	1.7	1.7	2	2.6	3.3
XB5-2	Binding head バインド	$d_k$ XB5-2	5.5	5.5	6.3	8.3	10.3
		$k+f$ XB5-2	1.6	1.6	1.9	2.5	3.1
XB5-6	Flanged pan head つば付きなべ	$d_k$ XB5-6	6.5	6.5	8	10	12
		$k$ XB5-6	2.1	2.1	1.75	3.2	4

**1-9. Hexagon Socket Set Screws**  
六角穴付止めねじ

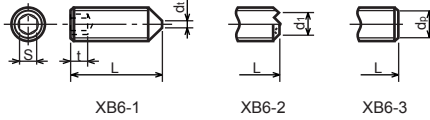

Type No. 類別番号	Type 類別	Head size (mm) 頭部寸法 (mm)							
		M1.6 M1.7	M2	M2.5 M2.6	M3	M5	M5	M6	
XB6-1	Cone point とがり先	S	0.7	0.9	1.3	1.5	2	2.5	3
		t	1.5	1.7	2	2	2.5	3	3.5
		$d_{t \max}$ XB6-1	0.4	0.5	0.65	0.75	1	1.25	1.5
		$d_{l \max}$ XB6-2	-	1.2	1.5	1.7	2.2	2.8	3.3
		$d_{l \min}$ XB6-2	-	1	1.2	1.4	1.9	2.4	2.9
XB6-2	Double point ダブルポイント	$d_{p \max}$ XB6-3	0.8	1	1.5	2	2.5	3.5	4
XB6-3	Flat point 平先	$d_{p \min}$ XB6-3	0.55	0.75	1.25	1.75	2.25	3.2	3.7

**1-10. Flanged Pan Head Machine Screws**  
つば付きなべ小ねじ

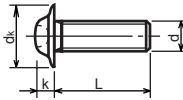

Type No. 類別番号	Type 類別	Head size (mm) 頭部寸法 (mm)					
		M2	M2.5 M2.6	M3	M5	M5	
XB6-7	Flanged pan head つば付きなべ	$d_k$	5	6.5	8	10	12
		k	1.7	2.1	2.5	3.2	4

# FIGURE ZZC MECHANICAL STANDARD PARTS (BOLTS)

## 2. Bolts (Socket head cap screw)

ボルト

How to read Parts Numbers

部品番号の見方

Bolt (Socket head cap screw)

ボルト

XB7-1080-409

Type No.  
類別番号

Normal designation (d)  
ねじの呼び (d)

Length (L)  
ねじの長さ (L)

Material and Surface treatment

材料および表面処理

XB7-1 expresses Hexagon socket head cap screws.

XB7-1は、六角穴付きボルトを表す

080 expresses M8.0.

080は、M8.0を表す

40 expresses a length of 40mm.

40は、40mmの長さを表す

9 expresses Steel (Black zinc trivalent chromate treating) from Table 1.

9は、表1より鋼(黒色亜鉛3価クロメート)を表す

### 2-1. Hexagon socket head cap screws

六角穴付きボルト

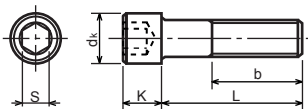

Type No. 類別番号	Type 類別
XB7-1	Hexagon socket head cap screws 六角穴付きボルト

	Head size (mm) 頭部寸法 (mm)					
	M3	M4	M5	M6	M8	M10 M12
S	2.5	3	4	5	6	8 10
d <sub>k</sub>	5.5	7	8.5	10	13	16 18
K	3	4	5	6	8	10 12
Screw part length ねじ部長さ b <sub>max</sub>	18	20	22	24	28	32 36



# FIGURE ZZD MECHANICAL STANDARD PARTS (NUTS)

## 3. Nuts ナット

How to read Parts Numbers  
部品番号の見方

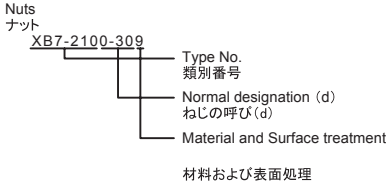

XB7-210 expresses Hexagon nut class 1.  
XB7-210は、六角ナット1種を表す

0-30 expresses M3.0.  
0-30は、M3.0を表す

9 expresses Steel (Black zinc trivalent chromate treating) from Table 1.  
9は、表1より鋼(黒色亜鉛3価クロメート)を表す

### 3-1. Hexagon Nuts and Hexagon Thin Nuts 六角ナット

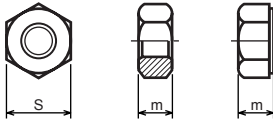

Type No. 類別番号	Type 類別
XB7-210	Hexagon nut Class 1 六角ナット-1種
XB7-220	Hexagon nut Class 3 六角ナット-3種
XB7-230	Hexagon nut Style 1 double chamfered 六角ナット-スタイル1-両面とり
XB7-231	Hexagon nut Style 1 washer faced 六角ナット-スタイル1-座付き
XB7-240	Hexagon nut Style 2 double chamfered 六角ナット-スタイル2-両面とり
XB7-241	Hexagon nut Style 2 washer faced 六角ナット-スタイル2-座付き
XB7-250	Hexagon nut 六角ナット
XB7-260	Hexagon thin nut double chamfered 六角低ナット-両面とり
XB7-270	Hexagon thin nut not chamfered 六角低ナット-面とり無し

	Head size (mm) 頭部寸法 (mm)						
	M2	M2.5	M3	M4	M5	M6	M8
S	4	5	5.5	7	8	10	13
m XB7-210	1.6	2	2.4	3.2	4	5	6.5
m XB7-220	1.2	1.6	1.8	2.4	3.2	3.6	5
m XB7-230, 231	1.6	2	2.4	3.2	4.7	5.2	6.8
m XB7-240, 241	-	-	-	-	5.1	5.7	7.5
m XB7-250	-	-	-	-	5.6	6.1	7.9
m XB7-260	1.2	1.6	1.8	2.2	2.7	3.2	4
m XB7-270	1.2	1.6	1.8	2.2	2.7	3.2	4

# FIGURE ZZE MECHANICAL STANDARD PARTS (RETAINING RINGS)

## 5. Retaining Rings

止め輪

How to read Parts Numbers  
部品番号の見方

### Retaining Rings

止め輪

XD2-1100-202

Type No.  
類別番号

Nominal designation  
呼び

Material and Surface treatment  
材料および表面処理

XD2-110 expresses retaining ring-E type (Type1).  
XD2-110は、E形止め輪(1種)を表す

0-20 expresses a 020 of nominal designation.  
(See Table 5)

0-20は、呼び020を表す(表5参照)

2 expresses Stainless steel (Surface treatment is not to be given) from Table 1.

2は、表1よりステンレス(表面処理なし)を表す

### 5-1. Retaining Rings - E type

E形止め輪

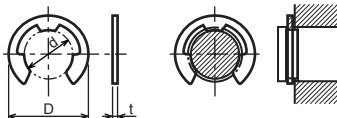

Type No. 類別番号	Type 類別
XD2-110	Retaining ring - E type (Type 1) E形止め輪(1種)
XD2-120	Retaining ring - E type (Type 2) E形止め輪(2種)

Table 5 表5

Type 種類	Nominal designation 呼び	d (mm)	D (mm)	t (mm)
Type 1 1種	007	0.65	2	0.2
	010	0.95	2.8	0.2
	013	1.25	3.3	0.3
	017	1.65	4.2	0.4
	020	1.95	4.6	0.5
	024	2.35	6	0.6
	028	2.74	6.5	0.6
	032	3.14	7.2	0.6
	037	3.64	8	0.7
	040	3.93	10	0.7
	042	4.13	10	0.7
	050	4.93	11	0.7
	058	5.73	12	0.7
	060	5.93	12.7	0.9
	064	6.32	13.5	0.9
	074	7.31	15	0.9
080	7.91	16.5	1	
Type 2 2種	008	0.8	2	0.2
	012	1.2	3	0.3
	015	1.5	4	0.4
	020	2	5	0.4
	025	2.5	6	0.4
	030	3	7	0.6
	040	4	9	0.6
	050	5	11	0.6
	060	6	12	0.8
	070	7	14	0.8
	080	8	16	0.8
	090	9	18	0.8
	100	10	20	1

5-2. Grip Rings  
グリップ止め輪

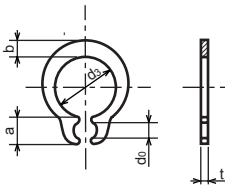

Type No. 類別番号	Type 類別
XD2-210	Grip ring グリップ止め輪

Table 5 表5

Nominal designation 呼び	d <sub>3</sub> (mm)	t (mm)	b (mm)	a (mm)	d <sub>0</sub> (mm)
020	1.9	0.5	1	1.8	0.8
025	2.35	0.5	1.2	1.9	0.9
030	2.85	0.6	1.4	1.9	0.9
035	3.3	0.6	1.6	2	0.9
040	3.8	0.8	1.8	2.8	1.2
045	4.25	0.8	2	2.9	1.3
050	4.75	0.8	2.2	2.9	1.3
060	5.7	1	2.4	3.1	1.4
070	6.7	1	2.7	3.3	1.4
080	7.7	1	3	3.5	1.4
090	8.65	1.2	3.3	4.7	1.5
100	9.65	1.2	3.5	4.7	2

5-3. Toothed Retaining Rings  
歯付き形止め輪

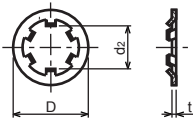

Type No. 類別番号	Type 類別
XD2-230	Toothed retaining ring 歯付き形止め輪

Table 5 表5

Nominal designation 呼び	d <sub>z</sub> (mm)	D (mm)	t (mm)	No of teeth 歯数
015	1.4	5.2	0.25	3
020	1.9	6	0.25	3
024	2.3	6.4	0.25	3
030	2.8	8	0.25	4
040	3.8	9	0.25	4
050	4.8	10	0.25	5
060	5.8	11	0.25	5
080	7.8	13	0.25	5
100	9.8	15.4	0.25	6

### 5-4. Retaining Rings - C Type

C形止め輪

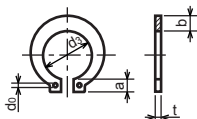

Type No. 類別番号	Type 類別
XD2-310	Retaining ring - C type for shaft C形止め輪 軸用

Table 5 表5

Nominal designation 呼び	d <sub>3</sub> (mm)	t (mm)	b (mm)	a (mm)	d <sub>0</sub> (mm)
010	9.3	1	1.6	3	1.2
012	11.1	1	1.8	3.2	1.5
014	12.9	1	2	3.4	1.7
015	13.8	1	2.1	3.5	1.7
016	14.7	1	2.2	3.6	1.7
017	15.7	1	2.2	3.7	1.7
018	16.5	1.2	2.6	3.8	1.7
020	18.5	1.2	2.7	3.9	2
022	20.5	1.2	2.7	4.1	2
025	23.2	1.2	3.1	4.3	2
028	25.9	1.5	3.1	4.6	2
030	27.9	1.5	3.5	4.8	2
032	29.6	1.5	3.5	5	2.5
035	32.2	1.5	4	5.4	2.5

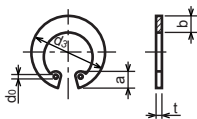

Type No. 類別番号	Type 類別
XD2-320	Retaining ring - C type for hole C形止め輪 穴用

Table 5 表5

Nominal designation 呼び	d <sub>3</sub> (mm)	t (mm)	b (mm)	a (mm)	d <sub>0</sub> (mm)
010	10.7	1	1.8	3.1	1.2
011	11.8	1	1.8	3.2	1.2
012	13	1	1.8	3.3	1.5
014	15.1	1	2	3.6	1.7
016	17.3	1	2	3.7	1.7
018	19.5	1	2.5	4	1.7
019	20.5	1	2.5	4	2
020	21.5	1	2.5	4	2
022	23.5	1	2.5	4.1	2
025	26.9	1.2	3	4.4	2
028	30.1	1.2	3	4.6	2
030	32.1	1.2	3	4.7	2
032	34.4	1.2	3.5	5.2	2.5
035	37.8	1.5	3.5	5.2	2.5
037	39.8	1.5	3.5	5.2	2.5
040	43.5	1.8	4	5.7	2.5
042	45.5	1.8	4	5.8	2.5
045	48.5	1.8	4.5	5.9	2.5
047	50.5	1.8	4.5	6.1	2.5
050	54.2	2	4.5	6.5	2.5
052	56.2	2	5.1	6.5	2.5
055	59.2	2	5.1	6.5	2.5
060	64.2	2	5.1	6.8	2.5
062	66.2	2	5.5	6.9	2.5
068	72.5	2.5	6	7.4	2.5
072	76.5	2.5	6.6	7.4	2.5
075	79.5	2.5	6.6	7.8	2.5
080	85.5	2.5	7	8	2.5
085	90.5	3	7	8	3
090	95.5	3	7.6	8.3	3
095	100.5	3	8	8.5	3

Prepared by  
OIP Business Support Group  
CANON INC.

**Canon**