



KM-1500

PARTS LIST

Published in Feb.'03
842DC120

NOTE

1. Indicate parts number and machine model when placing an order.

eg.	Parts Number	Parts Name	Machine Model	Cycle	Quantity
	2DC04030	COVER REAR	KM-1500	50Hz	1

2. Service calls and freight will be charged separately.

3. Symbols in the "Parts Number" column.

- Parts with "●" indicates the spare parts and the parts without "●" can not be supplied.
- Parts with "•" are component parts or sub-assemblies of the assembly appearing immediately above them.

eg.	Parts Number	Parts Name	Parts Number	Parts Name
	2DC93100	PARTS,MPF COVER SP	•2A806730	TRAY MPF A
			•2A806740	TRAY MPF B

4. See the last page of this parts list for the classification of the screws in the illustrations.

———— CONTENTS ————

FIG.1	EXTERIOR COVERS	2
FIG.2	FRAMES & PAPER FEED SECTION I	4
FIG.3	PAPER FEED SECTION II & LSU	8
FIG.4	DRIVING SECTION	10
FIG.5	PROCESS UNIT	12
FIG.6	FUSER UNIT	14
FIG.7	CASSETTE	16
FIG.8	OPTICAL SECTION	18
FIG.9	OPERATION UNIT & ORIGINAL HOLDER	20
FIG.10	TOOLS & SUPPLIED PARTS	22
	• INDEX	24

FIG. 1 EXTERIOR COVERS

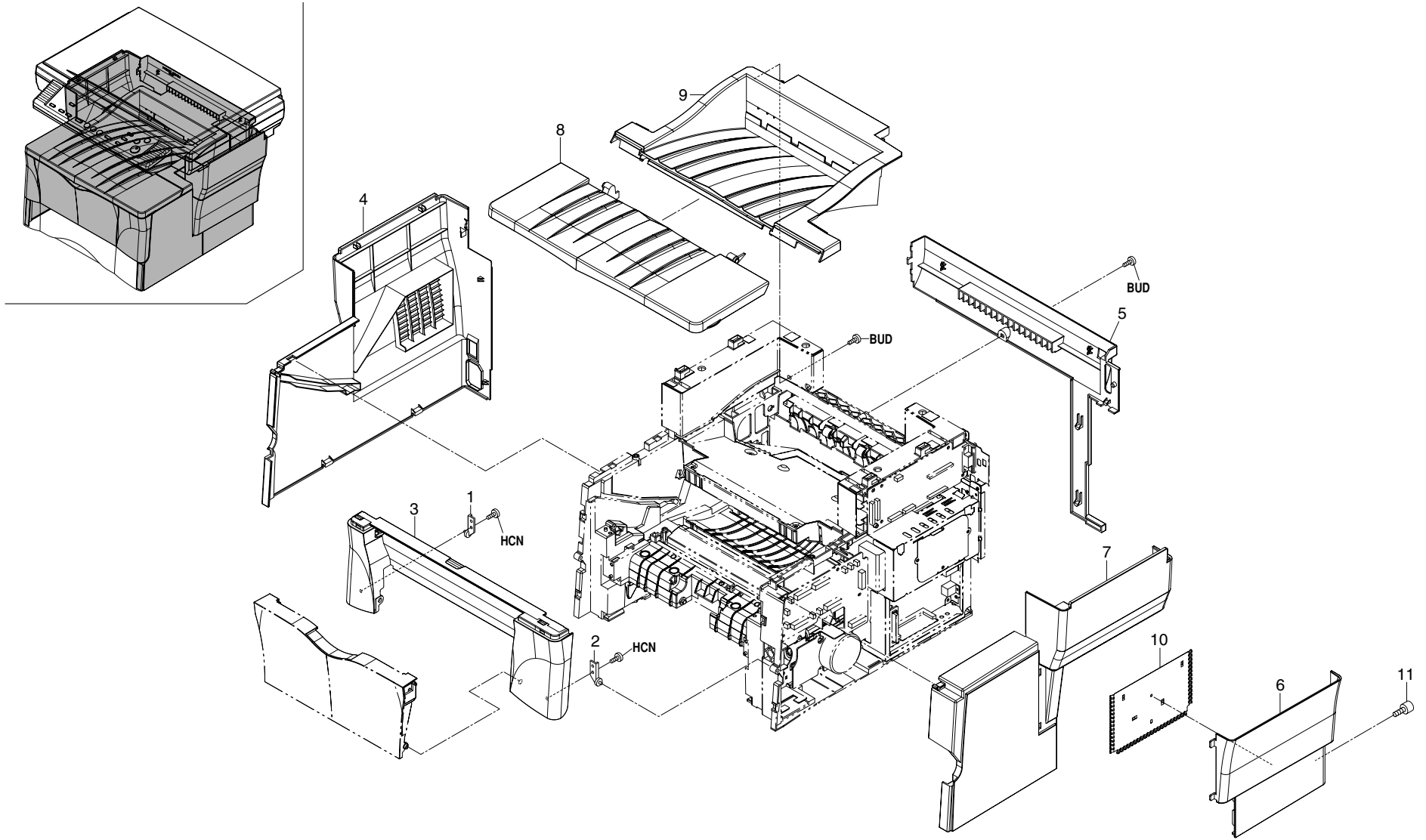

FIG. 1 EXTERIOR COVERS

2DC

SP	Ref. No.	Part. No.	KYOCERA Part Number	Description	Quantity		
					120V	230V	240V
	1	2A804080	5MVX422DN005	HINGE FRONT L	1	1	1
	2	2A804090	5MVX422DN006	HINGE FRONT R	1	1	1
●	3	2DC04010		COVER FRONT (1/2)	1	1	1
●	4	2DC04020		COVER LEFT (1/2)	1	1	1
	5	2DC04030		COVER REAR	1	1	1
●	6	2DC04050		COVER DIMM	1	1	1
●	7	2DC04060		COVER RIGHT (1/2)	1	1	1
●	8	2DD04020		LID TOP	1		1
●	8	2DC04100		LID TOP B		1	
●	9	2DC04080		COVER TOP (1/3)	1	1	1
	10	2DC04090		PLATE SHIELD	1	1	1
	11	2A802520	5MMT263SN012	SCREW OP	1	1	1

- Parts with "•" are component parts or sub-assemblies of the assembly appearing immediately above them.
- Parts with "●" indicates the spare parts.

- Parts with "••" are component parts or sub-assembly with "•" appearing immediately above them.

FIG. 2 FRAMES & PAPER FEED SECTION I

SP	Ref. No.	Part. No.	KYOCERA Part Number	Description	Quantity		
					120V	230V	240V
	1	2A802030	5MVB874CH002	COVER PWB	1	1	1
	2	2A802040	5MVX721DN001	LEVER INTERLOCK	1	1	1
	3	2A802050	5MVT653DW001	PIN CASSETTE	1	1	1
	4	2A802060	5MMW351LD006	SPRING INTERLOCK	1	1	1
	5	2A802070	5MMW341LD005	SPRING PIN CASSETTE	1	1	1
	6	2A806020	5MMT766SN007	SHAFT FEED	1	1	1
	7	2A806030	5MVM176DN026	BUSH FEED	2	2	2
●	8	2A806040	5MMT876SN073	ROLLER REGIST LOW	1	1	1
●	9	2A806050	5MMT865SN010	ROLLER REGIST UP	1	1	1
●	10	2A806090	5MVX432DB009	ACTUATOR REGIST	1	1	1
●	11	2A806100	5MVX542DB003	ACTUATOR PE	1	1	1
●	12	2A806120	5AAVCLTCH016	CLUTCH REGIST	1	1	1
	13	2A806170	5MVS441KF008	SHEET REGIST SW	1	1	1
	14	2A806210	5MMX532LD005	CONTACT EARTH REG	1	1	1
●	15	2A806220	5MVT676DB002	PULLEY FEED	1	1	1
●	16	2A806230	5MVG127DB047	GEAR REGIST Z20	1	1	1
●	17	2A806240	5MVG126DB025	GEAR REGIST Z13	1	1	1
●	18	2A806250	5MVX111DN003	RING STOPPER	4	4	4
	19	2A806260	5MVM161DW001	BUSH PULLEY FEED	2	2	2
	20	2A806410	5MMW261LD023	SPRING REGIST R	2	2	2
	21	2A806420	5MVX221DB019	BUSH REGIST LEFT	1	1	1
	22	2A806430	5MVX221DW006	BUSH REGIST RIGHT	1	1	1
●	23	2A806580	5AAVCLTCH017	CLUTCH MPF	1	1	1
	24	2A815010	5MMW361LD015	SPRING PIN BIAS	1	1	1
	25	2A815020	5MMT365SN003	PIN CONTACT BIAS	1	1	1
●	26	2A816020	5MVX221DB023	BUSH TC L	1	1	1
●	27	2A816030	5MVX221DW008	BUSH TC R	1	1	1
	28	2A816040	5MMW251LD043	SPRING TC L	1	1	1
	29	2DC16040		SPRING TC R	1	1	1
●	30	2A816060	5MVG127DB048	GEAR TC Z18	1	1	1
●	31	2A820090	5MMT874SN007	ROLLER EXIT UP	1	1	1
●	32	2A820290	5MVG137DN030	GEAR EXIT Z23 UP	1	1	1
	33	2A820300	5MVX322SB020	ACTUATOR FUSER B	1	1	1
	34	2A821010	5MVM176DW001	BUSH EXIT	1	1	1
●	35	2A822080	5MVG148DN045	GEAR Z38H	1	1	1
●	36	2A822090	5MVG148DN046	GEAR FREE Z40H	1	1	1
●	37	2A822100	5MVG138DN041	GEAR FREE Z25S	1	1	1
●	38	2A822110	5MVG148DN047	GEAR Z34S	1	1	1
●	39	2A822120	5MVG148DN048	GEAR Z40S	1	1	1
●	40	2A822130	5MMT364SN003	PIN DRIVE	3	3	3

- Parts with "●" are component parts or sub-assemblies of the assembly appearing immediately above them.
- Parts with "●●" indicates the spare parts.

2DC

SP	Ref. No.	Part. No.	KYOCERA Part Number	Description	Quantity		
					120V	230V	240V
●	41	2A822140	5MMW271LD010	SPRING FREE	1	1	1
●	42	2A822160	5MVG148DN049	GEAR Z37S	1	1	1
	43	2A822200	5MVB663SB048	COVER CORD	1	1	1
	44	2A827010	5MMS775SL001	PLATE CONTROLLER	1	1	1
	45	2A827030	5MMX773SL001	PLATE SW REG	1	1	1
	46	2A827060	5MVS765KF001	SHEET SW REG	1	1	1
●	47	2DC06030		ROLLER FEED ASSY	1	1	1
	48	2BY02010	5MMX632LD008	CONTACT MAIN MR	1	1	1
	49	2BY06040	5MMW261LD057	SPRING ACTUATOR REG	1	1	1
	50	2BY06050	5MVS622KF011	SHEET REGIST R	1	1	1
	51	2BY06060	5MVS622KF012	SHEET REGIST L	1	1	1
●	52	2DC68120		P.W.BOARD ASSY(SP)	1	1	1
●	53	2DC68110		P.W.BOARD ASSY(SP)	1	1	1
●	54	2DC01060		P.W.BOARD ASSY	1	1	1
	55	2DC02010		FRAME BASE (1/8)	1	1	1
	56	2DC02020		STAY SCANNER LEFT	1	1	1
	57	2DC02030		STAY SCANNER RIGHT	1	1	1
	58	2DC02040		FRAME MIDDLE (1/3)	1	1	1
	59	2DC02050		MOUNT SCANNER PCB	1	1	1
	60	2DC02060		PLATE EARTH STAY L	1	1	1
●	61	2DC06010		CLUTCH FEED	1	1	1
●	62	2DC16010		ROLLER TRANSFER,(C)		1	1
●	62	2DC16020		ROLLER TRANSFER,(I)	1		
	63	2DC16030		PLATE EARTH BRUSH A	1	1	1
●	64	2DC23010		FAN COOLING	1	1	1
	65	2DC26010		SHIELD CONTROLLER (1/3)	1	1	1
	66	2DC26080		GROUND PLATE SR	1	1	1
	67	2DC26100		CONTACT TRANSFER	1	1	1
	68	2DC27010		CONN.CORD ASSY ENGINE-MAIN	1	1	1
	69	2DC27020		CONN.CORD ASSY ENGINE-SCANNER1	1	1	1
	70	2DC27030		CONN.CORD ASSY ENGINE-SCANNER2	1	1	1
	71	2DC27110		CONN.CORD ASSY ENGINE-MMOT	1	1	1
	72	2DC27120		CONN.CORD ASSY ENGINE-BIASH	1	1	1
	73	2DC27130		CONN.CORD ASSY ENGINE-BIASY	1	1	1
●	74	2DC28080		TRANS ASSY	1	1	1
	75	2A868610	5AAAY3010E+31	EARTH GUIDE ASSY	1	1	1
	76	2DC02090		PLATE EARTH STAY L2	1	1	1
	77	2DC02100		FILM PS LOW	1	1	1
	78	2DC26130		FILM MAIN PWB	1	1	1
●	79	2DC28070		PRINTED W.BOARD PS100	1		

- Parts with "●●" are component parts or sub-assembly with "●" appearing immediately above them.

FIG. 2 FRAMES & PAPER FEED SECTION I

2DC

SP	Ref. No.	Part. No.	KYOCERA Part Number	Description	Quantity		
					120V	230V	240V
●	79	2DC28100		PRINTED W.BOARD PS200		1	1
	80	2DC26120		TAPE FFC M/S	1	1	1
	81	2DC27160		CORE FFC2	1	1	1

- Parts with "•" are component parts or sub-assemblies of the assembly appearing immediately above them.
- Parts with "●" indicates the spare parts.

- Parts with "••" are component parts or sub-assembly with "•" appearing immediately above them.

FIG. 3 PAPER FEED SECTION II & LSU

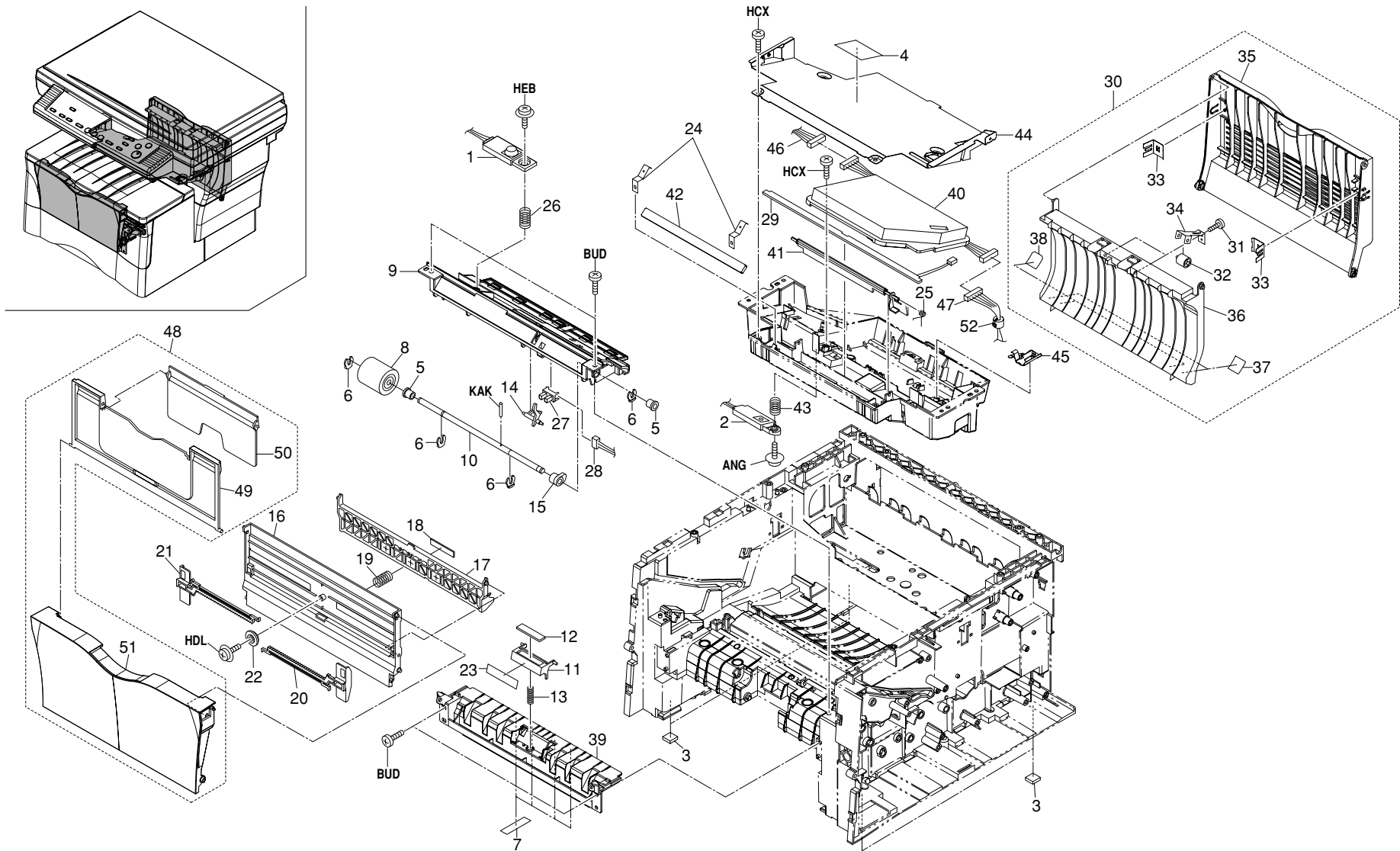

FIG. 3 PAPER FEED SECTION II & LSU

SP	Ref. No.	Part. No.	KYOCERA Part Number	Description	Quantity		
					120V	230V	240V
●	1	2DC68090		TE SENSOR ASSY	1	1	1
●	2	2DC68100		FULL SENSOR ASSY	1	1	1
	3	2A802500	5MVS228RB019	FOOT	4	4	4
	4	2A805010	5MVL661WN34	LABEL LASER CAUTION	1	1	1
	5	2A806030	5MVM176DN026	BUSH FEED	2	2	2
●	6	2A806250	5MVX111DN003	RING STOPPER	4	4	4
	7	2A806480	5MVS312KF011	SHEET GUIDE	4	4	4
●	8	2A806510	5AAVROLL*045	ROLLER MPF ASSY	1	1	1
	9	2A806520	5MVX854SH002	HOLDER MP FEED	1	1	1
	10	2A806530	5MMT766SN008	SHAFT MPF	1	1	1
	11	2A806550	5MVX522DB004	SEPARATOR MPF	1	1	1
	12	2A806560	5MVS416XN001	PAD SEPARATOR MPF	1	1	1
	13	2A806570	5MMW261LD038	SPRING SEPA MPF	1	1	1
	14	2A806600	5MVX432DB010	ACTUATOR MPF	1	1	1
	15	2A806620	5MVX221DN014	CAM MPF R	1	1	1
	16	2A806660	5MVB872SH019	BASE MPF	1	1	1
	17	2A806670	5MVX852CB003	BOTTOM PLATE MPF	1	1	1
	18	2A806680	5MVS616XN002	PAD BOTTOM MPF	1	1	1
	19	2A806690	5MMW271SZ005	SPRING BOTTOM MPF	1	1	1
	20	2A806700	5MVX752SH002	GUIDE MPF R	1	1	1
	21	2A806710	5MVX752SH003	GUIDE MPF L	1	1	1
	22	2A806720	5MVG137DN032	GEAR MPF	1	1	1
	23	2A806760	5MVS431TX001	TAPE SEPARATOR	1	1	1
	24	2A813030	5MMX221LD024	SPRING MIRROR	2	2	2
	25	2A813050	5MMW341LD006	SPRING SHUTTER LSU	1	1	1
	26	2A814570	5MMW261LD036	SPRING TE SENSOR	1	1	1
●	27	2A827110	5ENXGPIA73A*01	PT SENSOR	1	1	1
	28	2A827580	5AACCNRM0GEA	CONN.CORD ASSY	1	1	1
●	29	2DC01170		P.W.BOARD ASSY	1	1	1
●	30	2A868700	5AAY3010E+58	COVER REAR ASSY	1	1	1
●	31	*B8023060		BINDING TAP-TITE B SCREW M3X6	2	2	2
●	32	*2A820100	5MVM273DB005	PULLEY EXIT	2	2	2
	33	*2A820340	5MMX322LD022	PLATE TRAY	2	2	2
	34	*2A820850	5MMX332LD021	BKT PULLEY FD	2	2	2
●	35	*2A820950	5MVB874SH018	COVER REAR	1	1	1
	36	*2A820961	5MVB874SH019	TRAY EXIT FU	1	1	1
	37	*2A820970	5MVS222KN006	SHEET REAR	2	2	2
	38	*2A820980	5MVS222KW001	SHEET REAR B	2	2	2
	39	2DC06020		GUIDE TURN A	1	1	1
●	40	2DC93070		LK-100 PARTS LASER SCANNER	1	1	1

- Parts with "●" are component parts or sub-assemblies of the assembly appearing immediately above them.
- Parts with "●●" indicates the spare parts.

2DC

SP	Ref. No.	Part. No.	KYOCERA Part Number	Description	Quantity		
					120V	230V	240V
	41	2DC13020		SHUTTER LSU	1	1	1
	42	2DC13030		MIRROR LSU	1	1	1
	43	2DC13040		SPRING FULL SENSOR	1	1	1
	44	2DC26070		SHIELD LSU	1	1	1
	45	2DC26110		PLATE EARTH LSU	1	1	1
	46	2DC27070		WIRE MAIN-LSU	1	1	1
	47	2DC27140		WIRE ENGINE-LSU	1	1	1
●	48	2DC93100		PARTS.MPF COVER SP	1	1	1
	49	*2A806730	5MVX861SH004	TRAY MPF A	1	1	1
	50	*2A806740	5MVX751SH001	TRAY MPF B	1	1	1
●	51	*2DC04040		COVER MPF	1	1	1
	52	2A627940		CORE 10-20X10	1	1	1

- Parts with "●●" are component parts or sub-assembly with "●" appearing immediately above them.

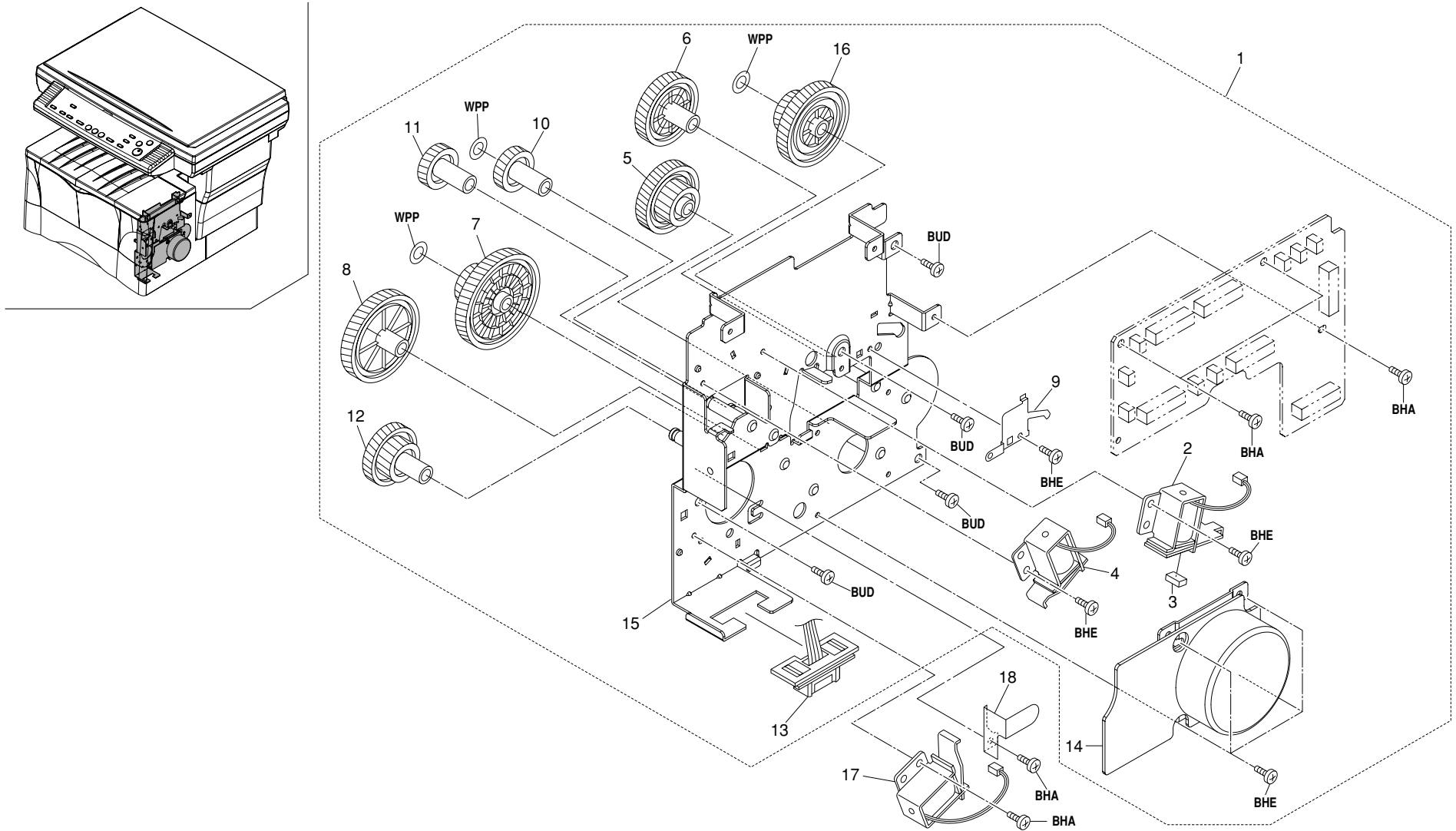

FIG. 4 DRIVING SECTION

2DC

SP	Ref. No.	Part. No.	KYOCERA Part Number	Description	Quantity		
					120V	230V	240V
●	1	2DC93080		DR-100PARTS DRIVE UNIT	1	1	1
●	2	•2A806141	5EZSA2402410401	SOLENOID REGIST	1	1	1
	3	•2A806280	5MVS217SN002	PAD SOLENOID	1	1	1
●	4	•2A806590	5EZSA2402410501	SOLENOID MPF	1	1	1
●	5	•2A822030	5MVG168DN017	GEAR Z68H-Z21H	1	1	1
●	6	•2A822050	5MVG148DN044	GEAR Z40H	1	1	1
●	7	•2A822060	5MVG169DN032	GEAR Z95H-Z21H	1	1	1
●	8	•2A822070	5MVG169DN033	GEAR Z53H	1	1	1
	9	•2A822150	5MMX521LD005	PLATE EARTH DRUM	1	1	1
●	10	•2A822170	5MVG138DN042	GEAR Z24H	1	1	1
●	11	•2A822180	5MVG137DN029	GEAR Z21H	1	1	1
●	12	•2A822190	5MVG148DN050	GEAR Z36H-Z21H	1	1	1
	13	•2A827590	5AACNRM1GEA	CONN.CORD ASSY	1	1	1
●	14	•2DC22010		MOTOR MAIN	1	1	1
	15	•2DC22020		MOUNT MACHINE DRIVE	1	1	1
●	16	•2DC22030		GEAR 48/21	1	1	1
●	17	2A806130	5EZSA2402410301	SOLENOID FEED	1	1	1
	18	2A806750	5MMX332LD013	PLATE EARTH MPF	1	1	1

- Parts with "•" are component parts or sub-assemblies of the assembly appearing immediately above them.
- Parts with "●" indicates the spare parts.

- Parts with "••" are component parts or sub-assembly with "•" appearing immediately above them.

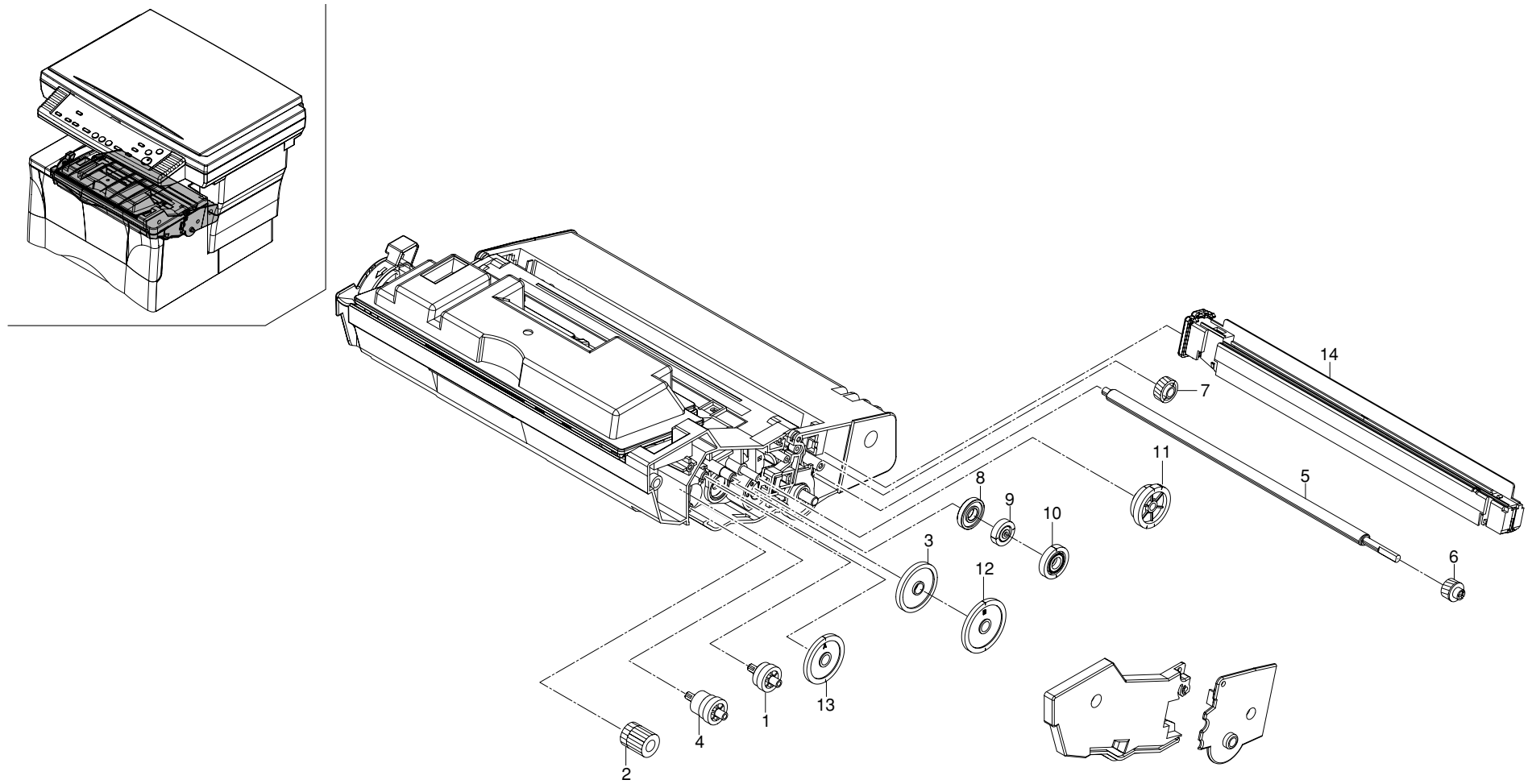

FIG. 5 PROCESS UNIT

SP	Ref. No.	Part. No.	KYOCERA Part Number	Description	Quantity		
					120V	230V	240V
●		2DC93030		PU-100 PARTS PROCESS UNIT SP		1	1
●		2DC93040		PU-101 PARTS PROCESS UNIT (U) SP	1		
●	1	*2A814190	5MVG127DN067	GEAR MIXER Z20 A	1	1	1
●	2	*2A814230	5MVG127DN068	GEAR Z14-Z18	1	1	1
●	3	*2A814240	5MVG148DN056	GEAR Z40	1	1	1
●	4	*2A814470	5MVG127DN069	GEAR MIXER Z20 B	1	1	1
●	5	*2A818080	5MVT865SB002	ROLLER SWEEP	1	1	1
●	6	*2A818220	5MVG127DN065	GEAR SWEEP Z13	1	1	1
●	7	*2A818230	5MVG127DN066	GEAR IDLE Z18H	1	1	1
●	8	*2BZ14610	5MVM187DB009	PULLEY DLP	2	2	2
●	9	*2DC14100		GEAR DLP 20	1	1	1
●	10	*2DC14110		GEAR DLP 24	1	1	1
●	11	*2DC14120		GEAR DLP 14/26/30	1	1	1
●	12	*2DC14140		GEAR DLP 18/44	1	1	1
●	13	*2DC14150		GEAR DLP 18/40	1	1	1
●	14	*2A893062	5PLPXU5AEKX	MC-40 MCH ASSY	1	1	1

- Parts with "•" are component parts or sub-assemblies of the assembly appearing immediately above them.
- Parts with "●" indicates the spare parts.

- Parts with "••" are component parts or sub-assembly with "•" appearing immediately above them.

FIG. 6 FUSER UNIT

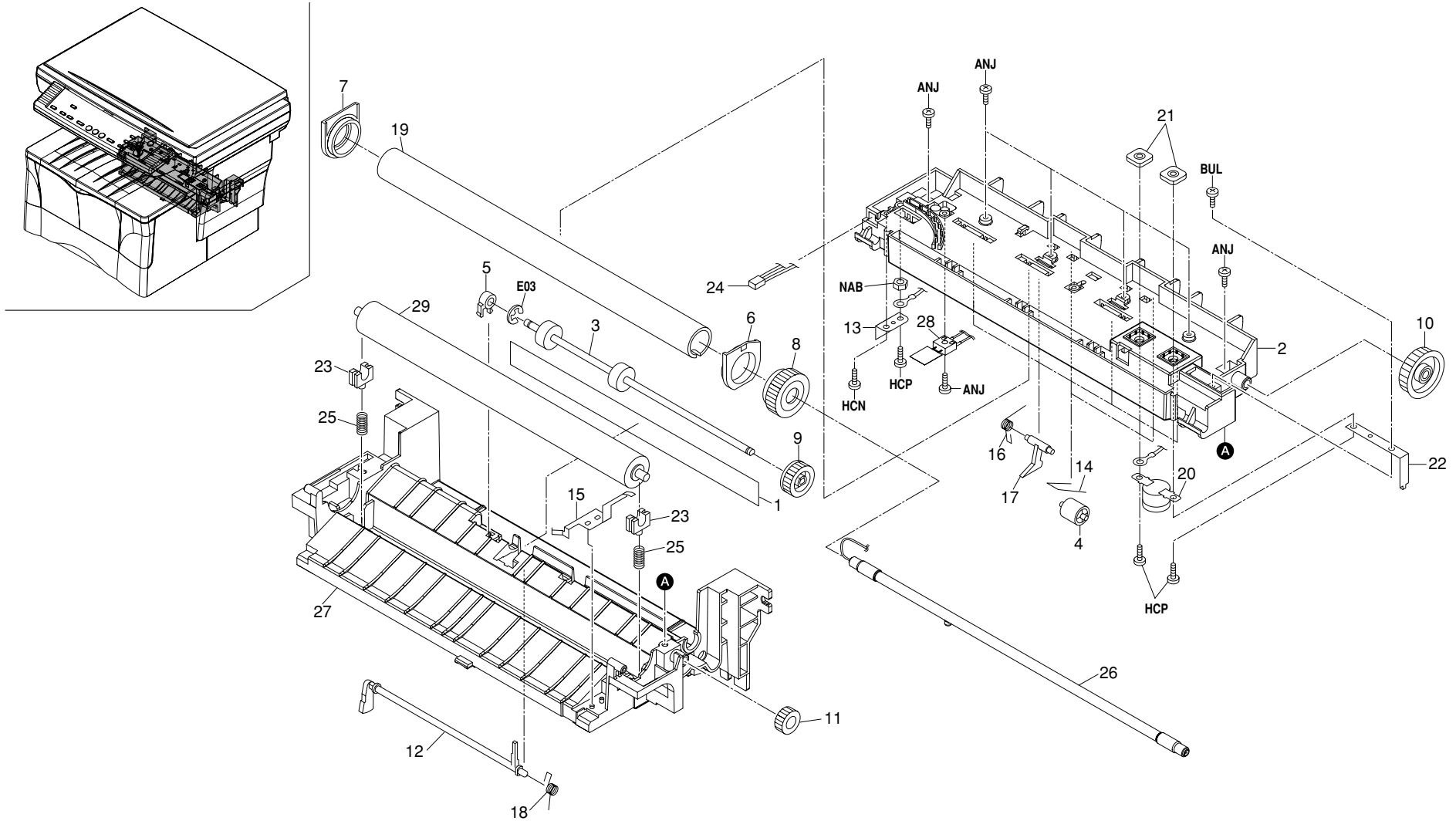

FIG. 6 FUSER UNIT

2DC

SP	Ref. No.	Part. No.	KYOCERA Part Number	Description	Quantity		
					120V	230V	240V
●		2DC93050		FK-100(E) PARTS FUSER UNIT		1	1
●		2DC93060		FK-100(U) PARTS FUSER UNIT	1		
	1	*2A805020	5MVL731WN14	LABEL FUSER CAUTION	1	1	1
	2	*2A820022	5MVB863KB003	FRAME FUSER UP	1	1	1
●	3	*2A820080	5MMT774SN001	ROLLER EXIT LOW	1	1	1
●	4	*2A820100	5MVM273DB005	PULLEY EXIT	2	2	2
	5	*2A820110	5MVX211DB016	BUSH EXIT	1	1	1
	6	*2A820120	5MVM188XN015	BUSH HEAT R	1	1	1
	7	*2A820131	5MVM188XN016	BUSH HEAT L	1	1	1
●	8	*2A820160	5MVG148XN008	GEAR HEAT Z33	1	1	1
●	9	*2A820170	5MVG137DN031	GEAR EXIT Z23	1	1	1
●	10	*2A820180	5MVG148XN009	GEAR IDLE Z34	1	1	1
●	11	*2A820190	5MVG127DN070	GEAR IDLE Z18	1	1	1
	12	*2A820200	5MVX731CB002	ACTUATOR FUSER A	1	1	1
	13	*2A820220	5MML211RD002	HOLDER LAMP B	1	1	1
	14	*2A820260	5MMW601LD011	SPRING PULLEY	2	2	2
	15	*2A820280	5MMX665LD004	PLATE EARTH FUSER	1	1	1
	16	*2A820350	5MMW261LD055	SPRING SEPARATOR	4	4	4
	17	*2A820360	5AAVSEPR015	SEPARATOR ASSY	4	4	4
	18	*2A820520	5MMW261LD017	SPRING ACTUATOR	1	1	1
●	19	*2BY20010	5MMT876AX002	ROLLER HEAT	1	1	1
●	20	*2BY20020	5EYFFQ16001++01	THERMOSTAT 250V 160	1	1	1
	21	*2BY20050	5MMS111SL002	NUT FUSER A	2	2	2
	22	*2BY20060	5MML531CG001	HOLDER LAMP A	1	1	1
	23	*2BY20070	5MVX221XN004	BUSH PRESS	2	2	2
	24	*2BY27560	5AACCN3H3GGEA	CONN.CORD ASSY S02774		1	1
	24	*2BY27570	5AACCN3H4GGEA	CONN.CORD ASSY S02775	1		
	25	*2DC20010		SPRING PRESS ROLLER	2	2	2
●	26	*2DC20020		HEATER 230 FIXING		1	1
●	26	*2DC20030		HEATER 120 FIXING	1		
	27	*2DC20040		FRAME FUSER LOW (1/2)	1	1	1
●	28	*2DC20050		THERMISTOR FUSER	1	1	1
	29	*2DC20060		ROLLER PRESS	1	1	1

- Parts with "•" are component parts or sub-assemblies of the assembly appearing immediately above them.
- Parts with "●" indicates the spare parts.

- Parts with "••" are component parts or sub-assembly with "•" appearing immediately above them.

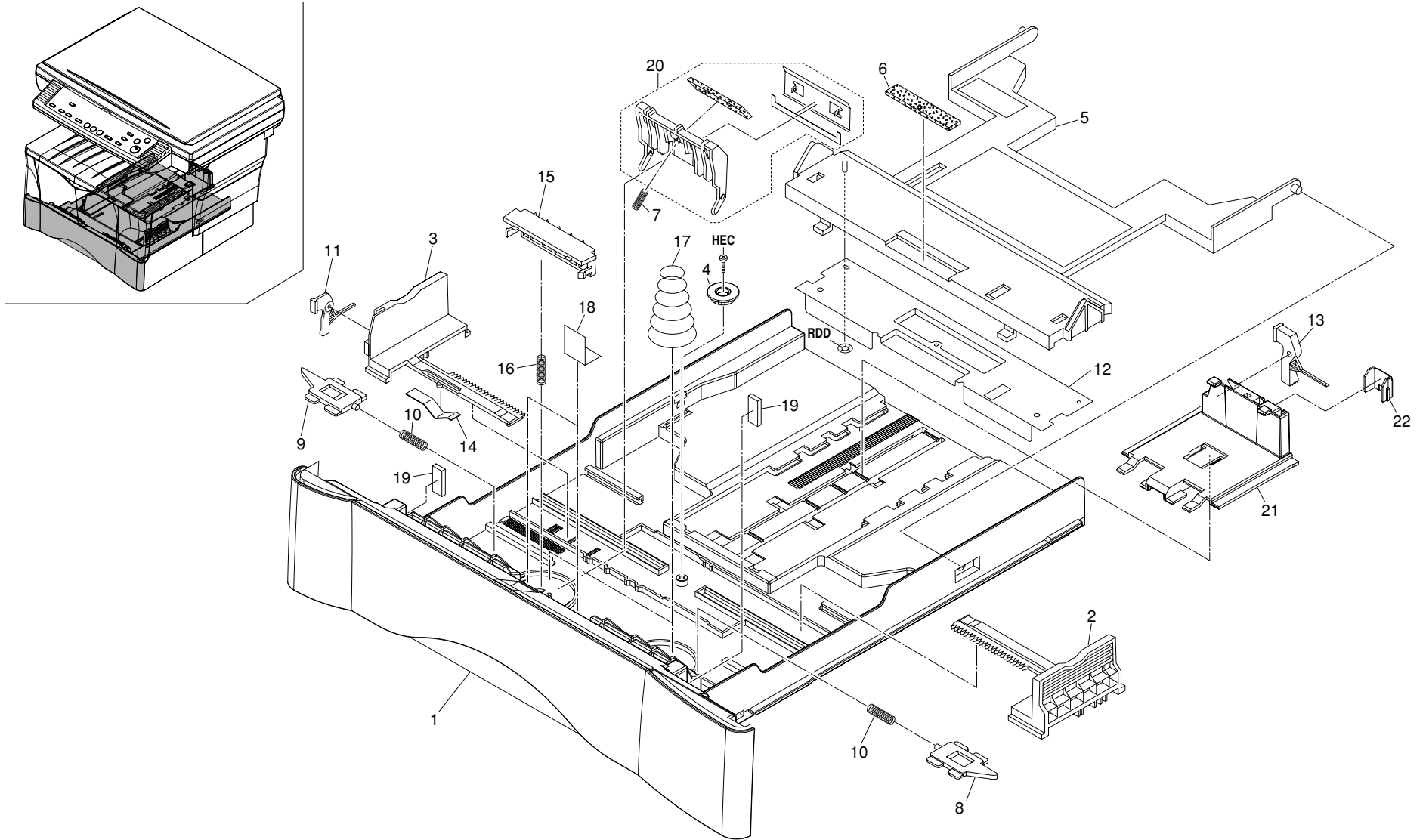

FIG. 7 CASSETTE

2DC

SP	Ref. No.	Part. No.	KYOCERA Part Number	Description	Quantity		
					120V	230V	240V
●		2DC93090		PARTS,CASSETTE SP	1	1	1
	1	*2A807010	5MVB886SH063	BASE CASSETTE	1	1	1
	2	*2A807020	5MVX765SH002	GUIDE SIDE R	1	1	1
	3	*2A807030	5MVX765SH003	GUIDE SIDE L	1	1	1
●	4	*2A807050	5MVG127DN071	GEAR CASSETTE	1	1	1
	5	*2A807060	5MVX882SH002	BOTTOM CASSETTE	1	1	1
	6	*2A807080	5MVS616XN001	PAD BOTTOM	1	1	1
	7	*2A807110	5MMW251LD047	SPRING SEPARATOR C	1	1	1
	8	*2A807121	5MVX431DW001	LOCK CASSETTE R	1	1	1
	9	*2A807131	5MVX431DW002	LOCK CASSETTE L	1	1	1
	10	*2A807140	5MMW251LD045	SPRING LOCK	2	2	2
	11	*2A807161	5MVX541DG003	LEVER SIDE	1	1	1
	12	*2A807170	5MMS856SL001	PLATE BOTTOM	1	1	1
	13	*2A807191	5MVX541DG002	LEVER REAR	1	1	1
	14	*2A807510	5MMP141LD002	PLATE SIDE GUIDE	1	1	1
	15	*2A807520	5MMP141LD003	PLATE STOPPER	1	1	1
●	16	*2A807530	5MMW171LD006	SPRING STOPPER	1	1	1
	17	*2DC07030		SPRING CASSETTE	2	2	2
	18	*2A807550	5MVL311KF003	SHEET CASSETTE	2	2	2
	19	*2A807910	5MVS315CN001	SPACER CASSETTE	2	2	2
	20	*2BX68340	5AAVSEPR016	SEPARATOR KIT	1	1	1
●	21	*2DC07010		STOPPER PAPER	1	1	1
●	22	*2DC07020		POSITIONING FOLIO PAPER	1	1	1

- Parts with "•" are component parts or sub-assemblies of the assembly appearing immediately above them.
- Parts with "●" indicates the spare parts.

- Parts with "••" are component parts or sub-assembly with "•" appearing immediately above them.

FIG. 8 OPTICAL SECTION

2DC

SP	Ref. No.	Part. No.	KYOCERA Part Number	Description	Quantity		
					120V	230V	240V
●	1	2DC01020		P.W.BOARD ASSY	1	1	1
	2	2DC05010		LABEL CONTACT GLASS	1	1	1
	3	2DC12010		UPPER FRAME SCANNER(1/2)	1	1	1
	4	2DC12020		LOWER FRAME SCANNER(1/4)	1	1	1
	5	2DC12040		SHAFT SCANNER	1	1	1
●	6	2DC12050		CONTACT GLASS	1	1	1
●	7	2DC12060		CONTACT GLASS DF	1	1	1
	8	2DC12110		MOUNT SCANNER MOTOR	1	1	1
●	9	2DC12120		GEAR SCANNER 39/22	1	1	1
●	10	2DC12130		GEAR SCANNER 45/18	1	1	1
	11	2DC12140		MOUNT TENSION PULLEY	1	1	1
●	12	2DC12150		PULLEY TENSION	1	1	1
●	13	2DC12160		MOTOR SCANNER	1	1	1
	14	2DC12170		SPRING TENSION	1	1	1
●	15	2DC12180		BELT SCANNER	1	1	1
	16	2DC12190		RAIL SCANNER	1	1	1
	17	2DC12210		STANDARD PLATE SHADING	1	1	1
●	18	2DC12280		STOPPER 8	1	1	1
	19	2DC12300		GROUND PLATE SCANNER	1	1	1
	20	2DC12310		HOLDER FFC	1	1	1
	21	2DC12330		PLATE EARTH SCANNER A	1	1	1
	22	2DC12340		PLATE EARTH SCANNER B	1	1	1
	23	2DC12350		PLATE EARTH SCANNER C	1	1	1
	24	2DC12360		TAPE CONTACT GLASS A	2	2	2
	25	2DC12370		TAPE CONTACT GLASS B	2	2	2
	26	2DC12380		TAPE CONTACT GLASS C	1	1	1
	27	2DC12390		TAPE CONTACT GLASS D	7	7	7
	28	2DC12400		TAPE FFC	2	2	2
●	29	2A806250	5MVX111DN003	RING STOPPER	2	2	2
●	30	2DC93010		PARTS,IMAGE SCANNER SP	1	1	1
●	31	•2DC12200		LAMP SCANNER	1	1	1
	32	•2DC27090		CONN.CORD ASSY SCANNER-CCD	1	1	1
	33	2DC27040		CONN.CORD ASSY SCANNER-MAIN1	1	1	1
	34	2DC27050		CONN.CORD ASSY SCANNER-PANEL	1	1	1
	35	2DC27080		CONN.CORD ASSY SCANNER-MAIN2	1	1	1
	36	2DC12420		PLATE EARTH SCANNER D	1	1	1
	37	2DC12430		PLATE EARTH SCANNER E	1	1	1
	38	2DC12440		PLATE EARTH SCANNER F	1	1	1
	39	2DC12450		PLATE EARTH SCANNER G	1	1	1
	40	2DC27150		CORE FFC1	1	1	1

SP	Ref. No.	Part. No.	KYOCERA Part Number	Description	Quantity		
					120V	230V	240V
	41	2BY26040		FERRITE CORE	1	1	1
	42	33927590		CORE 7-15X18	1	1	1

- Parts with "•" are component parts or sub-assemblies of the assembly appearing immediately above them.
- Parts with "●" indicates the spare parts.

- Parts with "••" are component parts or sub-assembly with "•" appearing immediately above them.

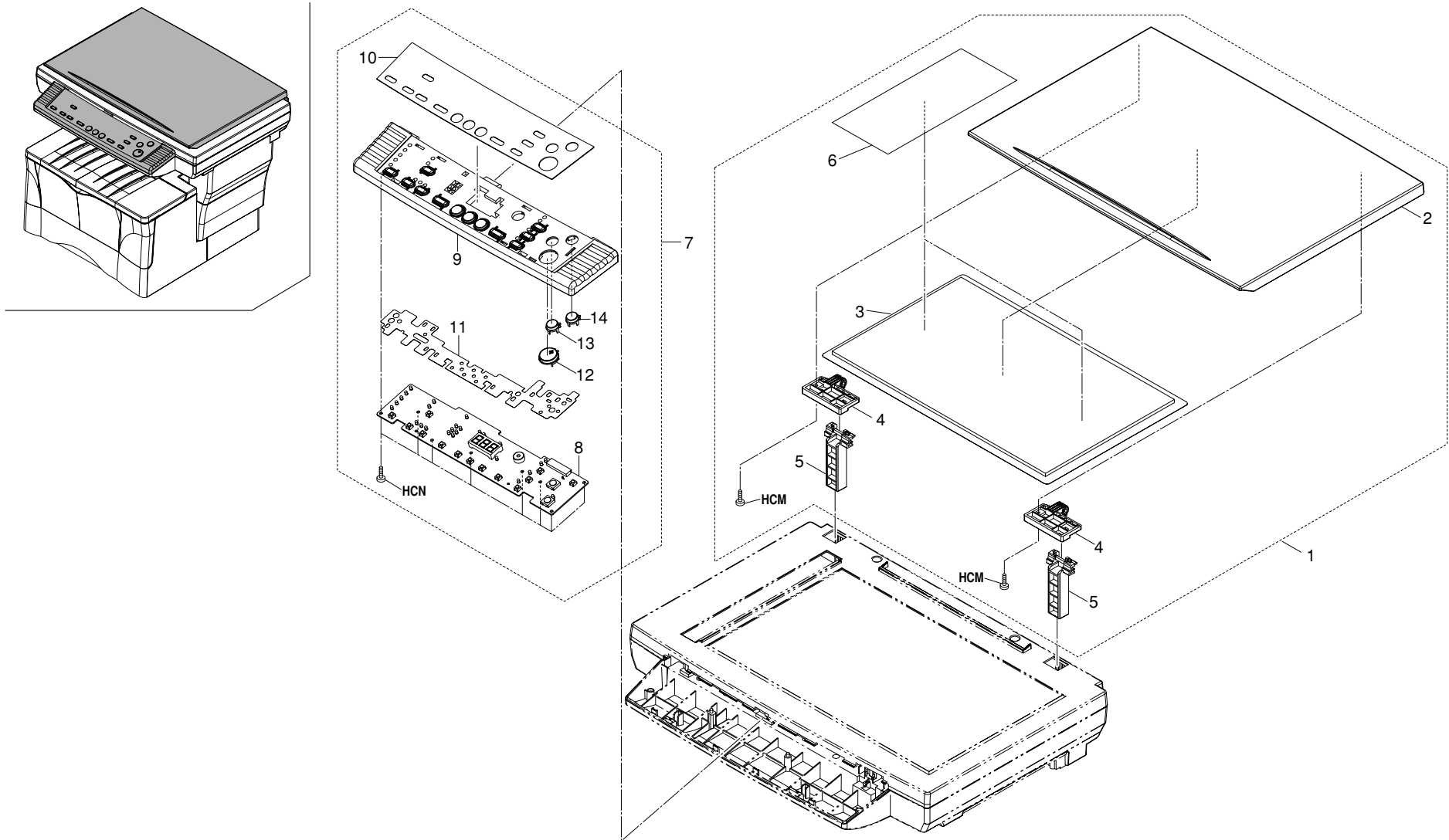

FIG. 9 OPERATION UNIT & ORIGINAL HOLDER

SP	Ref. No.	Part. No.	KYOCERA Part Number	Description	Quantity		
					120V	230V	240V
●	1	2DC93110		PARTS,PLATEN COVER SP	1	1	1
●	2	•2DC11010		COVER ORIGINAL HOLDER(1/2)	1	1	1
●	3	•2DC11020		MAT ORIGINAL HOLDER	1	1	1
●	4	•2DC11030		UPPER HINGE	2	2	2
●	5	•2DC11040		LOWER HINGE	2	2	2
●	6	•2DC11050		TAPE ORIGINAL HOLDER	2	2	2
●	7	2DC93020		PARTS,OPERATION PANEL,SP	1	1	1
●	8	•2DC01050		P.W.BOARD ASSY	1	1	1
●	9	•2DC25010		COVER OPERATION	1	1	1
●	10	•2DC25020		SHEET OPERATION	1	1	1
●	11	•2DC25030		SHEET DUST SHIELD	1	1	1
●	12	•2DC25050		KEY PRINT	1	1	1
●	13	•2DC25060		KEY STOP	1	1	1
●	14	•2DC25070		KEY RESET	1	1	1

- Parts with "•" are component parts or sub-assemblies of the assembly appearing immediately above them.
- Parts with "●" indicates the spare parts.

- Parts with "••" are component parts or sub-assembly with "•" appearing immediately above them.

TOOLS

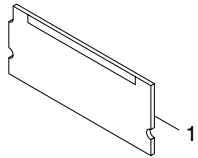

SUPPLIED PARTS

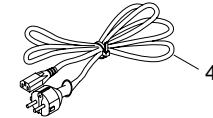
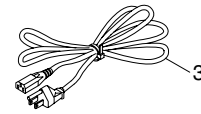
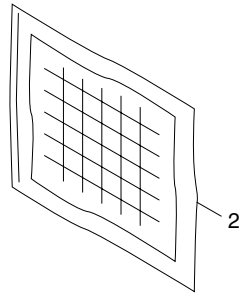

FIG. 10 TOOLS & SUPPLIED PARTS

2DC

SP	Ref. No.	Part. No.	KYOCERA Part Number	Description	Quantity		
					120V	230V	240V
●	1	2DC01090		PCB DIMM ASSY	1	1	1
	2	2A802530	5AAMDK5P**01	CLEANING KIT C	1	1	1
	3	2A827810	5AACAC482JULA	AC CORD ASSY	1		
	4	2A827830	5AACAC479EEA	AC CORD ASSY		1	1

- Parts with "•" are component parts or sub-assemblies of the assembly appearing immediately above them.
- Parts with "●" indicates the spare parts.

- Parts with "••" are component parts or sub-assembly with "•" appearing immediately above them.

INDEX

2DC

SP	Part. No.	KYOCERA Part Number	Description	Quantity			Fig. No.
				120V	230V	240V	
	2A627940		CORE 10-20X10	1	1	1	3
	2A802030	5MVB874CH002	COVER PWB	1	1	1	2
	2A802040	5MVV721DN001	LEVER INTERLOCK	1	1	1	2
	2A802050	5MVT653DW001	PIN CASSETTE	1	1	1	2
	2A802060	5MMV351LD006	SPRING INTERLOCK	1	1	1	2
	2A802070	5MMV341LD005	SPRING PIN CASSETTE	1	1	1	2
	2A802500	5MVS228RB019	FOOT	4	4	4	3
	2A802520	5MMT263SN012	SCREW OP	1	1	1	1
	2A802530	5AAMDK5P*01	CLEANING KIT C	1	1	1	10
	2A804080	5MVVX422DN005	HINGE FRONT L	1	1	1	1
	2A804090	5MVVX422DN006	HINGE FRONT R	1	1	1	1
	2A805010	5MVVL661VN34	LABEL LASER CAUTION	1	1	1	3
	2A805020	5MVVL731VN14	LABEL FUSER CAUTION	1	1	1	6
	2A806020	5MMT766SN007	SHAFT FEED	1	1	1	2
	2A806030	5MVM176DN026	BUSH FEED	4	4	4	2,3
●	2A806040	5MMT876SN073	ROLLER REGIST LOW	1	1	1	2
●	2A806050	5MMT865SN010	ROLLER REGIST UP	1	1	1	2
●	2A806090	5MVVX432DB009	ACTUATOR REGIST	1	1	1	2
●	2A806100	5MVVX542DB003	ACTUATOR PE	1	1	1	2
●	2A806120	5AAVCLTCH016	CLUTCH REGIST	1	1	1	2
●	2A806130	5EZSA2402410301	SOLENOID FEED	1	1	1	4
●	2A806141	5EZSA2402410401	SOLENOID REGIST	1	1	1	4
	2A806170	5MVS441KF008	SHEET REGIST SW	1	1	1	2
	2A806210	5MMVX532LD005	CONTACT EARTH REG	1	1	1	2
●	2A806220	5MVT676DB002	PULLEY FEED	1	1	1	2
●	2A806230	5MVG127DB047	GEAR REGIST Z20	1	1	1	2
●	2A806240	5MVG126DB025	GEAR REGIST Z13	1	1	1	2
●	2A806250	5MVVX111DN003	RING STOPPER	10	10	10	2,3,8
	2A806260	5MVM161DV001	BUSH PULLEY FEED	2	2	2	2
	2A806280	5MVS217SN002	PAD SOLENOID	1	1	1	4
	2A806410	5MMV261LD023	SPRING REGIST R	2	2	2	2
	2A806420	5MVVX221DB019	BUSH REGIST LEFT	1	1	1	2
	2A806430	5MVVX221DV006	BUSH REGIST RIGHT	1	1	1	2
	2A806480	5MVS312KF011	SHEET GUIDE	4	4	4	3
●	2A806510	5AAVROLL*045	ROLLER MPF ASSY	1	1	1	3
	2A806520	5MVVX854SH002	HOLDER MP FEED	1	1	1	3
	2A806530	5MMT766SN008	SHAFT MPF	1	1	1	3
	2A806550	5MVVX522DB004	SEPARATOR MPF	1	1	1	3
	2A806560	5MVS416XN001	PAD SEPARATOR MPF	1	1	1	3
	2A806570	5MMV261LD038	SPRING SEPA MPF	1	1	1	3

SP	Part. No.	KYOCERA Part Number	Description	Quantity			Fig. No.
				120V	230V	240V	
●	2A806580	5AAVCLTCH017	CLUTCH MPF	1	1	1	2
●	2A806590	5EZSA2402410501	SOLENOID MPF	1	1	1	4
	2A806600	5MVVX432DB010	ACTUATOR MPF	1	1	1	3
	2A806620	5MVVX221DN014	CAM MPF R	1	1	1	3
	2A806660	5MVB872SH019	BASE MPF	1	1	1	3
	2A806670	5MVVX852CB003	BOTTOM PLATE MPF	1	1	1	3
	2A806680	5MVS616XN002	PAD BOTTOM MPF	1	1	1	3
	2A806690	5MMV271SZ005	SPRING BOTTOM MPF	1	1	1	3
	2A806700	5MVVX752SH002	GUIDE MPF R	1	1	1	3
	2A806710	5MVVX752SH003	GUIDE MPF L	1	1	1	3
	2A806720	5MVG137DN032	GEAR MPF	1	1	1	3
	2A806730	5MVVX861SH004	TRAY MPF A	1	1	1	3
	2A806740	5MVVX751SH001	TRAY MPF B	1	1	1	3
	2A806750	5MMX332LD013	PLATE EARTH MPF	1	1	1	4
	2A806760	5MVS431TX001	TAPE SEPARATOR	1	1	1	3
	2A807010	5MVB886SH063	BASE CASSETTE	1	1	1	7
	2A807020	5MVVX765SH002	GUIDE SIDE R	1	1	1	7
	2A807030	5MVVX765SH003	GUIDE SIDE L	1	1	1	7
●	2A807050	5MVG127DN071	GEAR CASSETTE	1	1	1	7
	2A807060	5MVVX882SH002	BOTTOM CASSETTE	1	1	1	7
	2A807080	5MVS616XN001	PAD BOTTOM	1	1	1	7
	2A807110	5MMV251LD047	SPRING SEPARATOR C	1	1	1	7
	2A807121	5MVVX431DW001	LOCK CASSETTE R	1	1	1	7
	2A807131	5MVVX431DW002	LOCK CASSETTE L	1	1	1	7
	2A807140	5MMV251LD045	SPRING LOCK	2	2	2	7
	2A807161	5MVVX541DG003	LEVER SIDE	1	1	1	7
	2A807170	5MMS856SL001	PLATE BOTTOM	1	1	1	7
	2A807191	5MVVX541DG002	LEVER REAR	1	1	1	7
	2A807510	5MMP141LD002	PLATE SIDE GUIDE	1	1	1	7
	2A807520	5MMP141LD003	PLATE STOPPER	1	1	1	7
●	2A807530	5MMV171LD006	SPRING STOPPER	1	1	1	7
	2A807550	5MVL311KF003	SHEET CASSETTE	2	2	2	7
	2A807910	5MVS315CN001	SPACER CASSETTE	2	2	2	7
	2A813030	5MMX221LD024	SPRING MIRROR	2	2	2	3
	2A813050	5MMV341LD006	SPRING SHUTTER LSU	1	1	1	3
●	2A814190	5MVG127DN067	GEAR MIXER Z20 A	1	1	1	5
●	2A814230	5MVG127DN068	GEAR Z14-Z18	1	1	1	5
●	2A814240	5MVG148DN056	GEAR Z40	1	1	1	5
●	2A814470	5MVG127DN069	GEAR MIXER Z20 B	1	1	1	5
	2A814570	5MMV261LD036	SPRING TE SENSOR	1	1	1	3

• Parts with "●" indicates the spare parts.

SP	Part. No.	KYOCERA Part Number	Description	Quantity			Fig. No.
				120V	230V	240V	
	2A815010	5MMW361LD015	SPRING PIN BIAS	1	1	1	2
	2A815020	5MMT366SN003	PIN CONTACT BIAS	1	1	1	2
●	2A816020	5MVX221DB023	BUSH TC L	1	1	1	2
●	2A816030	5MVX221DW008	BUSH TC R	1	1	1	2
	2A816040	5MMW251LD043	SPRING TC L	1	1	1	2
●	2A816060	5MVG127DB048	GEAR TC Z18	1	1	1	2
●	2A818080	5MVT865SB002	ROLLER SWEEP	1	1	1	5
●	2A818220	5MVG127DN0065	GEAR SWEEP Z13	1	1	1	5
●	2A818230	5MVG127DN0066	GEAR IDLE Z18H	1	1	1	5
	2A820022	5MVB863KB003	FRAME FUSER UP	1	1	1	6
●	2A820080	5MMT774SN001	ROLLER EXIT LOW	1	1	1	6
●	2A820090	5MMT874SN007	ROLLER EXIT UP	1	1	1	2
●	2A820100	5MVM273DB005	PULLEY EXIT	4	4	4	3,6
	2A820110	5MVX211DB016	BUSH EXIT	1	1	1	6
	2A820120	5MVM188XN015	BUSH HEAT R	1	1	1	6
	2A820131	5MVM188XN016	BUSH HEAT L	1	1	1	6
●	2A820160	5MVG148XN008	GEAR HEAT Z33	1	1	1	6
●	2A820170	5MVG137DN031	GEAR EXIT Z23	1	1	1	6
●	2A820180	5MVG148XN009	GEAR IDLE Z34	1	1	1	6
●	2A820190	5MVG127DN070	GEAR IDLE Z18	1	1	1	6
	2A820200	5MVX731CB002	ACTUATOR FUSER A	1	1	1	6
	2A820220	5MML211RD002	HOLDER LAMP B	1	1	1	6
	2A820260	5MMW601LD011	SPRING PULLEY	2	2	2	6
	2A820280	5MMX666LD004	PLATE EARTH FUSER	1	1	1	6
●	2A820290	5MVG137DN030	GEAR EXIT Z23 UP	1	1	1	2
	2A820300	5MVX322SB020	ACTUATOR FUSER B	1	1	1	2
	2A820340	5MMX322LD022	PLATE TRAY	2	2	2	3
	2A820350	5MVMW261LD055	SPRING SEPARATOR	4	4	4	6
	2A820360	5AAVSEPR015	SEPARATOR ASSY	4	4	4	6
	2A820520	5MVMW261LD017	SPRING ACTUATOR	1	1	1	6
	2A820850	5MMX332LD021	BKT PULLEY FD	2	2	2	3
●	2A820950	5MVB874SH018	COVER REAR	1	1	1	3
	2A820961	5MVB874SH019	TRAY EXIT FU	1	1	1	3
	2A820970	5MVS222KN006	SHEET REAR	2	2	2	3
	2A820980	5MVS222KN001	SHEET REAR B	2	2	2	3
	2A821010	5MVM176DW001	BUSH EXIT	1	1	1	2
●	2A822030	5MVG168DN017	GEAR Z68H-Z21H	1	1	1	4
●	2A822050	5MVG148DN044	GEAR Z40H	1	1	1	4
●	2A822060	5MVG169DN032	GEAR Z95H-Z21H	1	1	1	4
●	2A822070	5MVG169DN033	GEAR Z53H	1	1	1	4

• Parts with "●" indicates the spare parts.

SP	Part. No.	KYOCERA Part Number	Description	Quantity			Fig. No.
				120V	230V	240V	
●	2A822080	5MVG148DN045	GEAR Z38H	1	1	1	2
●	2A822090	5MVG148DN046	GEAR FREE Z40H	1	1	1	2
●	2A822100	5MVG138DN041	GEAR FREE Z25S	1	1	1	2
●	2A822110	5MVG148DN047	GEAR Z34S	1	1	1	2
●	2A822120	5MVG148DN048	GEAR Z40S	1	1	1	2
●	2A822130	5MMT364SN003	PIN DRIVE	3	3	3	2
●	2A822140	5MMW271LD010	SPRING FREE	1	1	1	2
	2A822150	5MMX521LD005	PLATE EARTH DRUM	1	1	1	4
●	2A822160	5MVG148DN049	GEAR Z37S	1	1	1	2
●	2A822170	5MVG138DN042	GEAR Z24H	1	1	1	4
●	2A822180	5MVG137DN029	GEAR Z21H	1	1	1	4
●	2A822190	5MVG148DN050	GEAR Z36H-Z21H	1	1	1	4
	2A822200	5MVB663SB048	COVER CORD	1	1	1	2
	2A827010	5MMS775SL001	PLATE CONTROLLER	1	1	1	2
	2A827030	5MMX773SL001	PLATE SW REG	1	1	1	2
	2A827060	5MVS765KF001	SHEET SW REG	1	1	1	2
●	2A827110	5ENXGP1AT3A*01	PT SENSOR	1	1	1	3
	2A827580	5AACCNRM0GEA	CONN.CORD ASSY	1	1	1	3
	2A827590	5AACCNRM1GGEA	CONN.CORD ASSY	1	1	1	4
	2A827810	5AACAC482JULA	AC CORD ASSY	1			10
	2A827830	5AACAC479EEA	AC CORD ASSY		1	1	10
	2A868610	5AAY3010E+31	EARTH GUIDE ASSY	1	1	1	2
●	2A868700	5AAY3010E+58	COVER REAR ASSY	1	1	1	3
●	2A893062	5PLPXJ55AEKX	MC-40 MCH ASSY	1	1	1	5
	2BX68340	5AAVSEPR016	SEPARATOR KIT	1	1	1	7
	2BY02010	5MMX632LD008	CONTACT MAIN MR	1	1	1	2
	2BY06040	5MMW261LD057	SPRING ACTUATOR REG	1	1	1	2
	2BY06050	5MVS622KF011	SHEET REGIST R	1	1	1	2
	2BY06060	5MVS622KF012	SHEET REGIST L	1	1	1	2
●	2BY20010	5MMT876AX002	ROLLER HEAT	1	1	1	6
●	2BY20020	5EYFFQ16001+01	THERMOSTAT 250V 160	1	1	1	6
	2BY20050	5MMS111SL002	NUT FUSER A	2	2	2	6
	2BY20060	5MML531CG001	HOLDER LAMP A	1	1	1	6
	2BY20070	5MVX221XN004	BUSH PRESS	2	2	2	6
	2BY26040		FERRITE CORE	1	1	1	8
	2BY27560	5AACCNSH3GGEA	CONN.CORD ASSY S02774		1	1	6
	2BY27570	5AACCNSH4GGEA	CONN.CORD ASSY S02775	1			6
●	2BZ14610	5MVM187DB009	PULLEY DLP	2	2	2	5
●	2DC01020		P.W.BOARD ASSY	1	1	1	8

SP	Part. No.	KYOCERA Part Number	Description	Quantity			Fig. No.
				120V	230V	240V	
●	2DC01050		P.W.BOARD ASSY	1	1	1	9
●	2DC01060		P.W.BOARD ASSY	1	1	1	2
●	2DC01090		PCB DIMM ASSY	1	1	1	10
●	2DC01170		P.W.BOARD ASSY	1	1	1	3
	2DC02010		FRAME BASE (1/8)	1	1	1	2
	2DC02020		STAY SCANNER LEFT	1	1	1	2
	2DC02030		STAY SCANNER RIGHT	1	1	1	2
	2DC02040		FRAME MIDDLE (1/3)	1	1	1	2
	2DC02050		MOUNT SCANNER PCB	1	1	1	2
	2DC02060		PLATE EARTH STAY L	1	1	1	2
	2DC02090		PLATE EARTH STAY L2	1	1	1	2
	2DC02100		FILM PS LOW	1	1	1	2
●	2DC04010		COVER FRONT (1/2)	1	1	1	1
●	2DC04020		COVER LEFT (1/2)	1	1	1	1
	2DC04030		COVER REAR	1	1	1	1
●	2DC04040		COVER MPF	1	1	1	3
●	2DC04050		COVER DIMM	1	1	1	1
●	2DC04060		COVER RIGHT (1/2)	1	1	1	1
●	2DC04080		COVER TOP (1/3)	1	1	1	1
	2DC04090		PLATE SHIELD	1	1	1	1
●	2DC04100		LID TOP B		1		1
	2DC05010		LABEL CONTACT GLASS	1	1	1	8
●	2DC06010		CLUTCH FEED	1	1	1	2
	2DC06020		GUIDE TURN A	1	1	1	3
●	2DC06030		ROLLER FEED ASSY	1	1	1	2
●	2DC07010		STOPPER PAPER	1	1	1	7
●	2DC07020		POSITIONING FOLIO PAPER	1	1	1	7
	2DC07030		SPRING CASSETTE	2	2	2	7
●	2DC11010		COVER ORIGINAL HOLDER(1/2)	1	1	1	9
●	2DC11020		MAT ORIGINAL HOLDER	1	1	1	9
●	2DC11030		UPPER HINGE	2	2	2	9
●	2DC11040		LOWER HINGE	2	2	2	9
	2DC11050		TAPE ORIGINAL HOLDER	2	2	2	9
	2DC12010		UPPER FRAME SCANNER(1/2)	1	1	1	8
	2DC12020		LOWER FRAME SCANNER(1/4)	1	1	1	8
	2DC12040		SHAFT SCANNER	1	1	1	8
●	2DC12050		CONTACT GLASS	1	1	1	8
●	2DC12060		CONTACT GLASS DF	1	1	1	8
	2DC12110		MOUNT SCANNER MOTOR	1	1	1	8

SP	Part. No.	KYOCERA Part Number	Description	Quantity			Fig. No.
				120V	230V	240V	
●	2DC12120		GEAR SCANNER 39/22	1	1	1	8
●	2DC12130		GEAR SCANNER 45/18	1	1	1	8
	2DC12140		MOUNT TENSION PULLEY	1	1	1	8
●	2DC12150		PULLEY TENSION	1	1	1	8
●	2DC12160		MOTOR SCANNER	1	1	1	8
	2DC12170		SPRING TENSION	1	1	1	8
●	2DC12180		BELT SCANNER	1	1	1	8
	2DC12190		RAIL SCANNER	1	1	1	8
●	2DC12200		LAMP SCANNER	1	1	1	8
	2DC12210		STANDARD PLATE SHADING	1	1	1	8
●	2DC12280		STOPPER 8	1	1	1	8
	2DC12300		GROUND PLATE SCANNER	1	1	1	8
	2DC12310		HOLDER FFC	1	1	1	8
	2DC12330		PLATE EARTH SCANNER A	1	1	1	8
	2DC12340		PLATE EARTH SCANNER B	1	1	1	8
	2DC12350		PLATE EARTH SCANNER C	1	1	1	8
	2DC12360		TAPE CONTACT GLASS A	2	2	2	8
	2DC12370		TAPE CONTACT GLASS B	2	2	2	8
	2DC12380		TAPE CONTACT GLASS C	1	1	1	8
	2DC12390		TAPE CONTACT GLASS D	7	7	7	8
	2DC12400		TAPE FFC	2	2	2	8
	2DC12420		PLATE EARTH SCANNER D	1	1	1	8
	2DC12430		PLATE EARTH SCANNER E	1	1	1	8
	2DC12440		PLATE EARTH SCANNER F	1	1	1	8
	2DC12450		PLATE EARTH SCANNER G	1	1	1	8
	2DC13020		SHUTTER LSU	1	1	1	3
	2DC13030		MIRROR LSU	1	1	1	3
	2DC13040		SPRING FULL SENSOR	1	1	1	3
●	2DC14100		GEAR DLP 20	1	1	1	5
●	2DC14110		GEAR DLP 24	1	1	1	5
●	2DC14120		GEAR DLP 14/26/30	1	1	1	5
●	2DC14140		GEAR DLP 18/44	1	1	1	5
●	2DC14150		GEAR DLP 18/40	1	1	1	5
●	2DC16010		ROLLER TRANSFER,(C)		1	1	2
●	2DC16020		ROLLER TRANSFER,(I)	1			2
	2DC16030		PLATE EARTH BRUSH A	1	1	1	2
	2DC16040		SPRING TC R	1	1	1	2
	2DC20010		SPRING PRESS ROLLER	2	2	2	6
●	2DC20020		HEATER 230 FIXING		1	1	6
●	2DC20030		HEATER 120 FIXING	1			6

• Parts with "●" indicates the spare parts.

SP	Part. No.	KYOCERA Part Number	Description	Quantity			Fig. No.
				120V	230V	240V	
●	2DC20040		FRAME FUSER LOW (1/2)	1	1	1	6
	2DC20050		THERMISTOR FUSER	1	1	1	6
	2DC20060		ROLLER PRESS	1	1	1	6
●	2DC22010		MOTOR MAIN	1	1	1	4
	2DC22020		MOUNT MACHINE DRIVE	1	1	1	4
●	2DC22030		GEAR 48/21	1	1	1	4
●	2DC23010		FAN COOLING	1	1	1	2
●	2DC25010		COVER OPERATION	1	1	1	9
●	2DC25020		SHEET OPERATION	1	1	1	9
●	2DC25030		SHEET DUST SHIELD	1	1	1	9
●	2DC25050		KEY PRINT	1	1	1	9
●	2DC25060		KEY STOP	1	1	1	9
●	2DC25070		KEY RESET	1	1	1	9
	2DC26010		SHIELD CONTROLLER (1/3)	1	1	1	2
	2DC26070		SHIELD LSU	1	1	1	3
	2DC26080		GROUND PLATE SR	1	1	1	2
	2DC26100		CONTACT TRANSFER	1	1	1	2
	2DC26110		PLATE EARTH LSU	1	1	1	3
	2DC26120		TAPE FFC M/S	1	1	1	2
	2DC26130		FILM MAIN PWB	1	1	1	2
	2DC27010		CONN.CORD ASSY ENGINE-MAIN	1	1	1	2
	2DC27020		CONN.CORD ASSY ENGINE-SCANNER1	1	1	1	2
	2DC27030		CONN.CORD ASSY ENGINE-SCANNER2	1	1	1	2
	2DC27040		CONN.CORD ASSY SCANNER-MAIN1	1	1	1	8
	2DC27050		CONN.CORD ASSY SCANNER-PANEL	1	1	1	8
	2DC27070		WIRE MAIN-LSU	1	1	1	3
	2DC27080		CONN.CORD ASSY SCANNER-MAIN2	1	1	1	8
	2DC27090		CONN.CORD ASSY SCANNER-CCD	1	1	1	8
	2DC27110		CONN.CORD ASSY ENGINE-MMOT	1	1	1	2
	2DC27120		CONN.CORD ASSY ENGINE-BIASH	1	1	1	2
	2DC27130		CONN.CORD ASSY ENGINE-BIASY	1	1	1	2
	2DC27140		WIRE ENGINE-LSU	1	1	1	3
	2DC27150		CORE FFC1	1	1	1	8
	2DC27160		CORE FFC2	1	1	1	2
●	2DC28070		PRINTED W.BOARD PS100	1			2
●	2DC28080		TRANS ASSY	1	1	1	2
●	2DC28100		PRINTED W.BOARD PS200		1	1	2
●	2DC68090		TE SENSOR ASSY	1	1	1	3
●	2DC68100		FULL SENSOR ASSY	1	1	1	3
●	2DC68110		P.W.BOARD ASSY(SP)	1	1	1	2

SP	Part. No.	KYOCERA Part Number	Description	Quantity			Fig. No.
				120V	230V	240V	
●	2DC68120		P.W.BOARD ASSY(SP)	1	1	1	2
●	2DC93010		PARTS,IMAGE SCANNER SP	1	1	1	8
●	2DC93020		PARTS,OPERATION PANEL,SP	1	1	1	9
●	2DC93030		PU-100 PARTS PROCESS UNIT SP		1	1	5
●	2DC93040		PU-101 PARTS PROCESS UNIT (U) SP	1			5
●	2DC93050		FK-100(E) PARTS FUSER UNIT		1	1	6
●	2DC93060		FK-100(U) PARTS FUSER UNIT	1			6
●	2DC93070		LK-100 PARTS LASER SCANNER	1	1	1	3
●	2DC93080		DR-100PARTS DRIVE UNIT	1	1	1	4
●	2DC93090		PARTS,CASSETTE SP	1	1	1	7
●	2DC93100		PARTS,MPF COVER SP	1	1	1	3
●	2DC93110		PARTS,PLATEN COVER SP	1	1	1	9
●	2DD04020		LID TOP	1		1	1
	33927590		CORE 7-15X18	1	1	1	8
	B8023060		BINDING TAP-TITE B SCREW M3X6	2	2	2	3

• Parts with "●" indicates the spare parts.

CLASSIFICATION OF THE SCREWS IN ILLUSTRATION

<u>REF.</u>	<u>ITEM #</u>	<u>DESCRIPTION</u>	<u>REF.</u>	<u>ITEM #</u>	<u>DESCRIPTION</u>
ANG	B4073080	TRIPLE TAP-TITE B SCREW M3X8	HEC	B4090060	PEDESTALHEAD TAP-TIGHT B SCREW M3X6
ANJ	B8023120	BINDING TAP-TITE B SCREW M3X12	KAK	E0020080	SPRING PIN 2X8
BHA	B3023060	BINDING TAP TITE S SCREW M3X6	KDE	E1120100	SPRING PIN M2 X 10 SUS-DP XX
BHE	B3023050	BINDING TAP-TITE S SCREW M3X5	NAB	C1003000	NUT NM3
BUD	B8204100	BINDING TAP-TITE B SCREW M4X10	NAD	C1004000	NUT NM4
BUL	B8023060	BINDING TAP-TITE B SCREW M3X6	NCZ	B4213100	TRIPLE SCREW M3X10(UNICRO)
EMQ	B3204060	BINDING TAP-TITE S SCREW M4X6	NGL	C2806130	POLY SLIDER M6.2X 13X.25T PA
E03	D1000300	STOP RING (E-3)	RDD	D4000400	STOP RING CSTW-4
E05	D1000500	STOP RING (E-5)	TGB	C4204000	CROWN WASHER TWM4
HCM	B4213080	TRIPLE SCREW M3X8(UNICRO)	WPM	C2891100	POLY-SLIDER WASHER 4.1X10X0.3T
HCN	B8023080	BINDING TAP-TITE B SCREW M3X8	WPP	C2891080	POLY CUT WASHER 5.2X8X0.25T
HCP	B4003060	TRIPLE SEREW M3X6	XBE	C2894650	SHIM 4.1X0.25T
HCX	B8023100	BINDING TAP-TITE B SCREW M3X10	XCC	C2892950	SHIM 6.2X9.5X0.5T
HDL	B4073050	TRIPLE TAP-TITE B SCREW M3X5	XEJ	C3790080	WAVE WASHER SUS WW4.3X8X0.2T
HEB	B4094100	PEDESTALHEAD TAP-TITE B SCREW(CHROMATING)M4X10			