

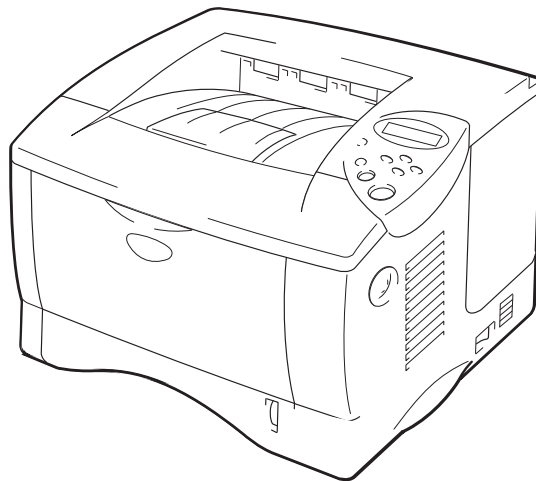

Brother Laser Printer **PARTS REFERENCE LIST**

MODEL: HL-1650/1670N



Read this list thoroughly before maintenance work.

Keep this list in a convenient place for quick and easy reference at all times.

PL-PRN009

NOTE FOR USING THIS PARTS REFERENCE LIST

1. In the case of ordering parts, it needs mentioning the following items:

- (1) Code
- (2) Q'ty
- (3) Description
- (4) Symbol (PCB No., Revision , and Parts location mounted on the PCB.)

Note : No orders without Parts Code or Tool No. can be accepted.

< Example >

REF.NO.	CODE	Q'TY	DESCRIPTION	SYMBOL	REMARK

Revision No.: marked on the **main printed circuit board**.

B48K056 - 201A

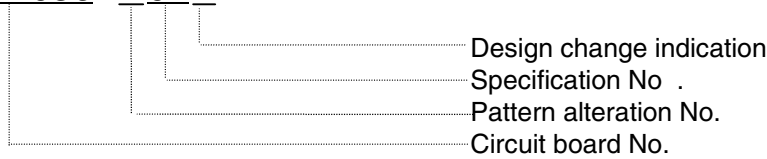

Revision No.: marked on the **power supply printed circuit board**.

Rev. A



2. Design-changed parts :

If the parts are changed, any one of the following symbols is indicated in the REMARKS column.

- #A : Compatible between old and new
- #B : Replaceable from old to new
- #D : Incompatible
- # : Newly established

3. The original of this list was made based on the information available in January 2001.

4. Parts are subject to change in design without prior notice.

CONTENTS

1.	<u>FRAME / DRIVE UNIT</u>	1
2.	<u>LASER UNIT</u>	1
3.	<u>PAPER FEEDER / MP UNIT</u>	3
4.	<u>DUPLEX</u>	5
5.	<u>PAPER CASSETTE</u>	7
6.	<u>FIXING UNIT</u>	9
7.	<u>COVERS</u>	11
8.	<u>MAIN PCB</u>	13
9.	<u>ENGINE PCB</u>	15
10.	<u>LOW-VOLTAGE POWER SUPPLY PCB</u>	15
11.	<u>HIGH-VOLTAGE POWER SUPPLY PCB</u>	17
12.	<u>AC CORDS</u>	17
13.	<u>ACCESSORIES</u>	19
14.	<u>PACKING MATERIALS</u>	21
15.	<u>NETWORK BOARD</u>	21
16.	<u>PERIODICAL MAINTENANCE PARTS</u>	23

1. FRAME / DRIVE UNIT

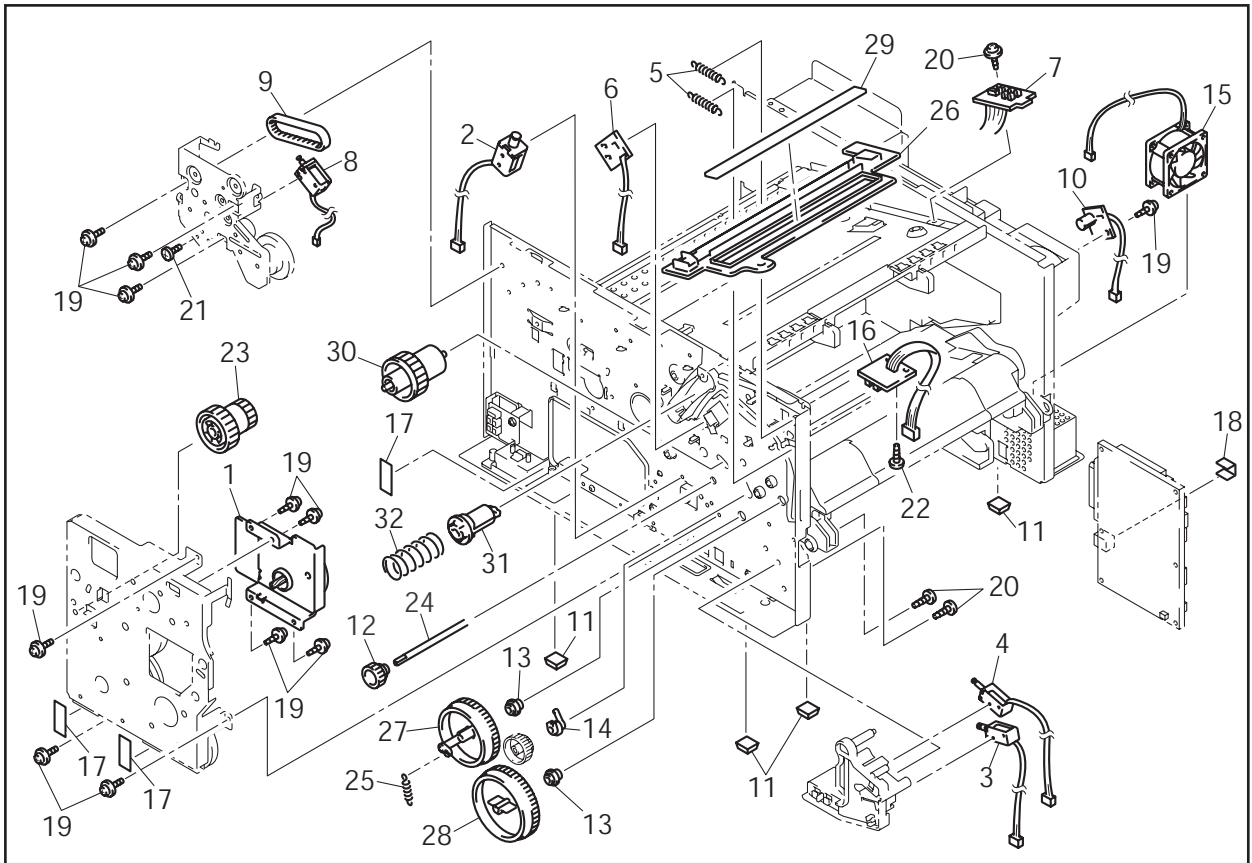

MODEL HL-1650/1670N 84U-Z21/Z22-010

2. LASER UNIT

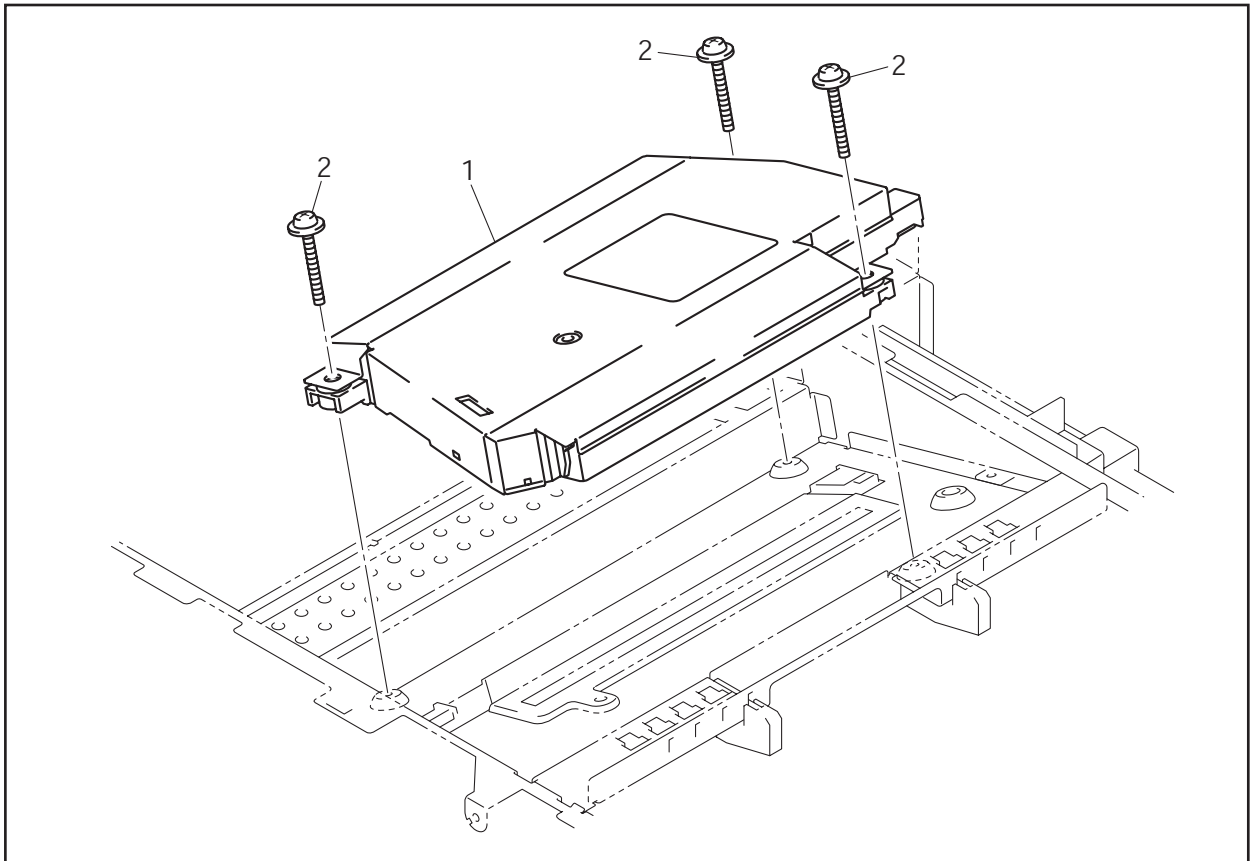

MODEL HL-1650/1670N 84U-Z21/Z22-020

1. FRAME / DRIVE UNIT

REF.NO.	CODE	Q'TY	DESCRIPTION	SYMBOL	REMARK
1	LJ5052001	1	MAIN MOTOR ASSY		
2	LJ5053001	1	FEED SOLENOID ASSY		
3	LJ5058001	1	SOLENOID ASSY P/R		
4	LJ5060001	1	SOLENOID ASSY MP		
5	LJ5208001	2	LOCK LEVER SPRING		
6	LJ5307001	1	TONER LED PCB UNIT (EMISSION)		
7	LJ8357001	1	SOL RELAY PCB ASSY		
8	LJ5088001	1	REVERSING SWITCH SOLENOID		
9	LJ5015001	1	T-BELT B40S2M142		
10	LJ5100001	1	TONER SENSOR PCB UNIT (RECEPTION)		
11	LJ7403001	4	RUBBER FOOT		
12	LJ5925001	1	GEAR 21 H		
13	UL9069001	2	CONDUCTOR BEARING 5		
14	LJ5533001	1	CONDUCTOR BEARING H		
15	LJ5117001	1	FAN MOTOR 60		
16	LJ8363001	1	DX SENSOR PCB ASSY		
17	LJ8724001	3	TAPE 60X12		
18	LE1169001	1	USB GROUND PLATE		
19	087320615	11	SCREW, CUP S TITE 3X6		
20	085411015	3	TAPTITE, BIND B M4X10		
21	000300415	1	SCREW, BIND M3X4		
22	085310815	1	TAPTITE, BIND B M3X8		
23	LJ5051001	1	FUSER DRIVE GEAR		
24	LJ5930001	1	FEED ROLLER GEAR SHAFT		
25	LJ5114001	1	SPRING, EXTENSIONS P/R		
26	LJ5107001	1	COVER GLASS HOLDER H		
27	LJ5112001	1	GEAR 60 P/R		add
28	LJ5115001	1	GEAR 72MP		add
29	UL9023001	1	COVER GLASS		add
30	LJ5109001	1	PENDULUM GEAR		ADD
31	LJ5064001	1	DEVELOP JOINT		ADD
32	LJ5065001	1	JOINT SPRING		ADD

MODEL HL-1650/1670N 84U-Z21/Z22-010

T/I NO. PR2001114 / PR2002063 / PR2002076 / PR2002139 / PR2002158

2. LASER UNIT

REF.NO.	CODE	Q'TY	DESCRIPTION	SYMBOL	REMARK
1	LJ5604001	1	LASER UNIT (SP)		
2	087321615	3	TAPTITE, CUP S M3X16		

MODEL HL-1650/1670N 84U-Z21/Z22-020

3. PAPER FEEDER / MP UNIT

PR2002067

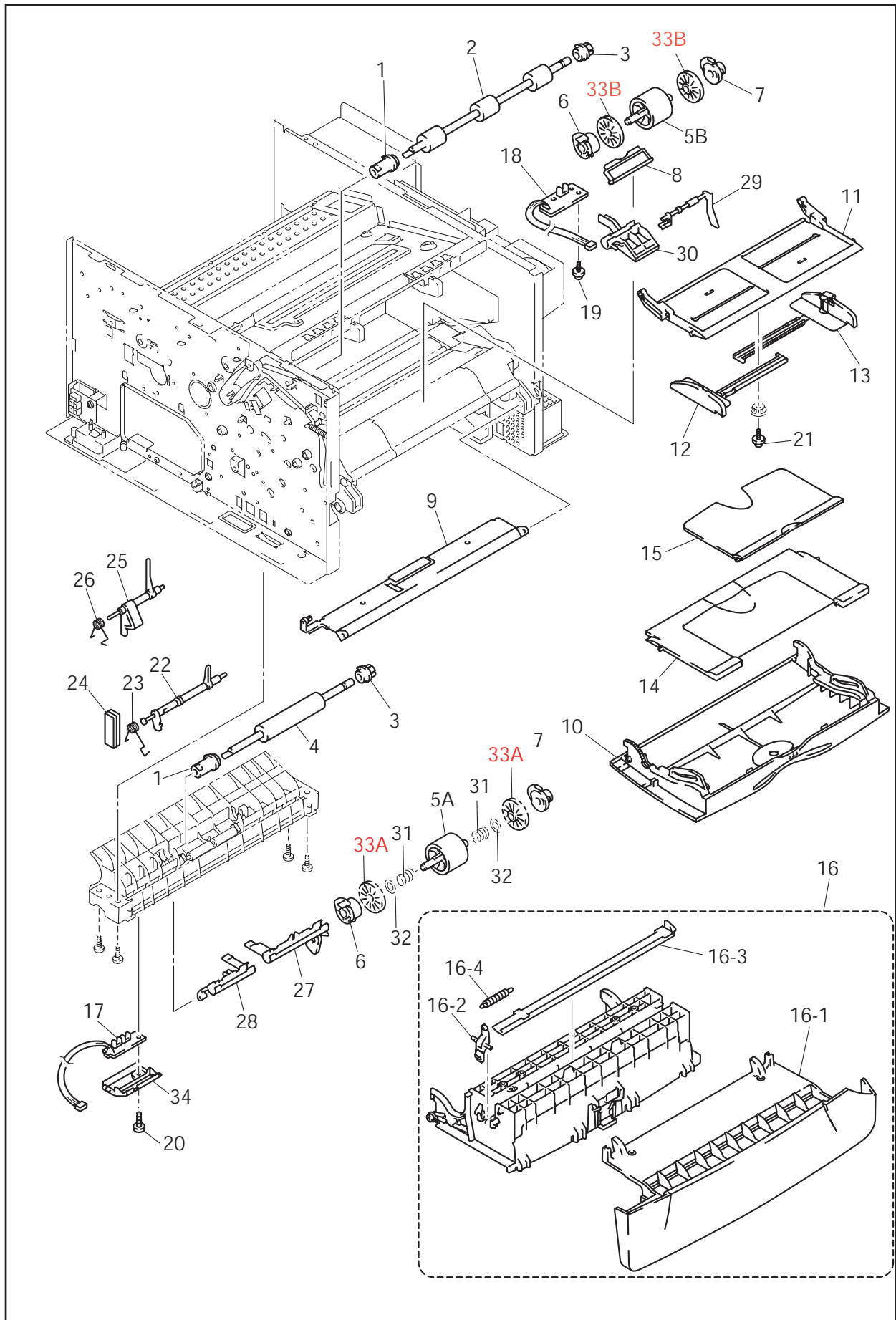

MODEL HL-1650/1670N 84U-Z21/Z22-041

T/I NO. PR2001032/PR2001114/PR2002067

3. PAPER FEEDER / MP UNIT

REF.NO.	CODE	Q'TY	DESCRIPTION	REMARK
1	UL9059001	2	JOINT 5	
2	UL9060001	1	FEED ROLLER ASSY	
3	UL9062001	2	BEARING 5	
4	LJ5146001	1	FIRST FEED ROLLER ASSY	
5A	LJ5016001	1	PAPER PICK-UP ROLLER ASSY *1	*1 A component part of the PAPER FEEDING KIT. Refer to "16. PERIODICAL MAINTENANCE PARTS".
5B	LJ5016001	1	PAPER PICK-UP ROLLER ASSY	
6	LJ5020001	2	BEARING L	
7	LJ5021001	2	BEARING R	
8	LJ5184001	1	SEPARATION PLATE ASSY	
9	LJ5188001	1	MP PRESSURE PLATE ASSY	
10	LJ5197001	1	MP COVER	
11	LJ5199001	1	MP PAPER GUIDE 1	
12	LJ5200001	1	MP SIDE GUIDE L	
13	LJ5201001	1	MP SIDE GUIDE R	
14	LJ5203001	1	MP PAPER GUIDE 2	
15	LJ5204001	1	MP PAPER GUIDE 3	
16	LJ5013001	1	PROCESS UNIT COVER ASSY	
16-1	LJ5205001	1	PROCESS UNIT COVER	
16-2	LJ5206001	1	P COVER LOCK LEVER L	
16-3	LJ5207001	1	P COVER LOCK LEVER R	
16-4	LJ5208001	1	LOCK LEVER SPRING	
17	LJ8365001	1	CASSETTE SENSOR PCB ASSY	
18	LJ8367001	1	MP SENSOR PCB ASSY	
19	087310815	1	TAPTITE, CUP B M3X8	
20	085311015	1	SCREW, BIND B TITE 3X10	
21	087310615	1	TAPTITE, CUP B M3X6	
22	LJ5131001	1	RESIST FRONT ACTUATOR	
23	LJ5132001	1	RESIST FRONT ACTUATOR SPRING	
24	LJ5626001	1	STOPPER H	
25	LJ5133001	1	RESIST REAR ACTUATOR	
26	LJ5134001	1	RESIST REAR ACTUATOR SPRING	
27	LJ7073001	1	PE ACTUATOR H	
28	LJ5155001	1	CA ACTUATOR	
29	LJ5162001	1	MP-PE SENSOR ACTUATOR 1	
30	LJ5163001	1	MP-PE SENSOR ACTUATOR 2	
31	LJ5915001	2	ROLLER COLLAR SPRING	
32	LJ5916001	2	ROLLER COLLAR WASHER	
33A	LJ5150001	2	ROLLER COLLAR	
33B	LJ5150001	2	ROLLER COLLAR	
34	LJ5211001	1	PE SENSOR COVER	ADD

MODEL HL-1650/1670N 84U-Z21/Z22-041

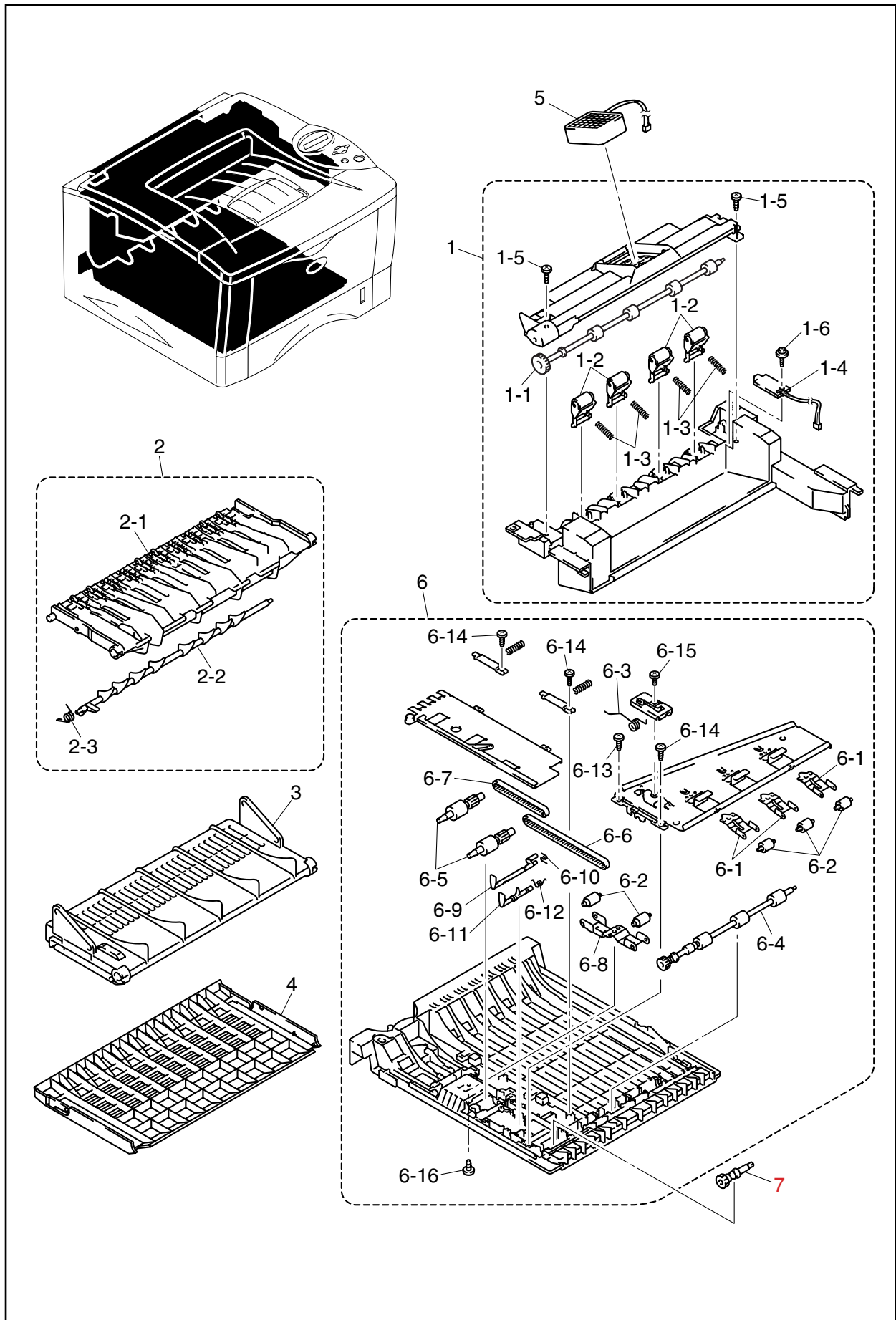

MODEL HL-1650/1670N 84U-Z21/Z22-042

T/I No. PR2001032 / PR2001114

4. DUPLEX

REF.NO.	CODE	Q'TY	DESCRIPTION	REMARK
1	LJ5216001	1	EXIT ROLLER UNIT	
1-1	LJ5220001	1	EXIT ROLLER ASSY ZLH	
1-2	UL9122001	4	PINCH ROLLER ASSY	
1-3	UL9125001	4	PINCH ROLLER SPRING	
1-4	LJ8364001	1	REAR COVER SENSOR PCB ASSY	
1-5	085411015	2	TAPTITE, BIND B M4X10	
1-6	087310815	1	TAPTITE, CUP B M3X8	
2	LJ5222001	1	DX OUTER CHUTE ASSY	
2-1	LJ5223001	1	DX OUTER CHUTE	
2-2	LJ5224001	1	FRAP 2	
2-3	LJ5225001	1	FRAP 2 SPRING	
3	LJ5226001	1	DX REAR CHUTE	
4	LJ5227001	1	REAR COVER C	
5	LJ5569001	1	FAN MOTOR 60 A UNIT	
6	LJ1887001	1	DX FEED ASSY 2	CHG
6-1	LJ7092001	3	ROLLER HOLDER HE	chg
6-2	UH2360000	5	PRESSURE ROLLER	
6-3	LJ5233001	1	GROUND WIRE	
6-4	LJ5235001	1	DX FEED ROLLER ASSY	
6-5	LJ5238001	2	SIDE REGIST ROLLER	
6-6	LJ5015001	1	T-BELT B40S2M142	
6-7	LJ5240001	1	T-BELT B40S2M224	
6-8	LJ5241001	1	SIDE REGIST ROLLER HOLDER	
6-9	LJ5248001	1	GUIDE ACTUATOR	
6-10	LJ5249001	1	GUIDE ACTUATOR SPRING	
6-11	LJ5250001	1	DX PAPER ACTUATOR	
6-12	LJ5251001	1	PAPER ACTUATOR SPRING	
6-13	LJ5616001	1	SHOULDER TAPTITE, BIND B 3X7.5A	
6-14	085310815	3	TAPTITE, BIND B M3X8	
6-15	060300415	1	SCREW, BIND M3X4	
6-16	085310515	1	TAPTITE, BIND M3X5	
7	LJ5237001	1	DRIVE GEAR 14	

MODEL HL-1650/1670N 84U-Z21/Z22-042

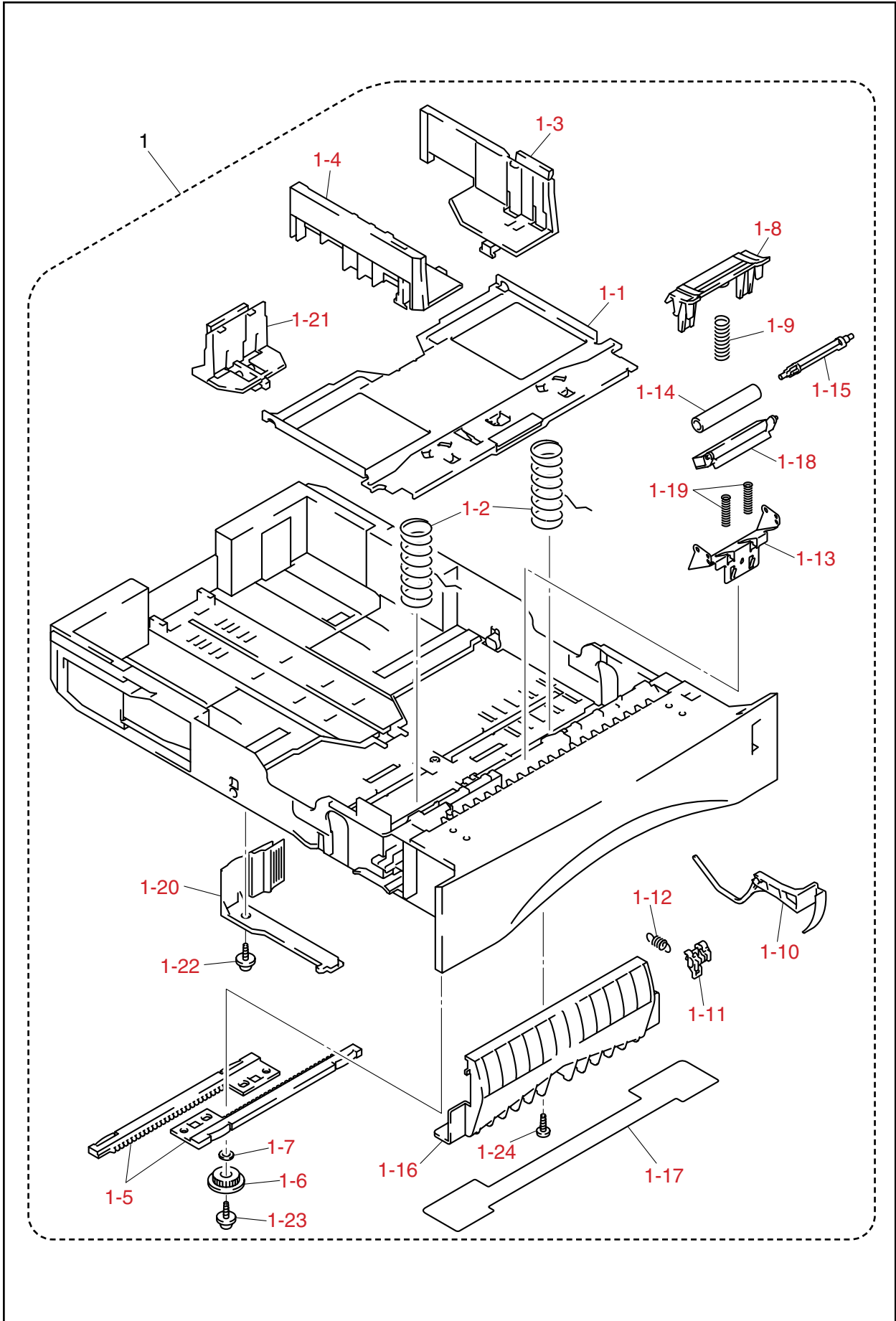

MODEL HL-1650/1670N 84U-Z21/Z22-046

5. PAPER CASSETTE

PR2001135

REF.NO.	CODE	Q'TY	DESCRIPTION	REMARK
1	LJ5002001	1	PAPER TRAY ASSY H2 BRO	
1-1	LJ4537001	1	PRESSURE PLATE ASSY LGL	
1-2	UL9077001	2	PERSSURE PLATE SPRING	
1-3	UL9078001	1	SIDE GUIDE L	
1-4	UL9079001	1	SIDE GUIDE R	
1-5	UL9080001	2	SIDE GUIDE RACK	
1-6	UL9081001	1	SIDE GUIDE GEAR	
1-7	UL9082001	1	FRICTION SPRING	
1-8	LJ5256001	1	PAD HOLDER ZLH ASSY *2	*2 A component part of the PAPER FEEDING KIT. Refer to "16. PERIODICAL MAINTENANCE PARTS".
1-9	LJ5923001	1	SEPARATION PAD SPRING 350	
1-10	LJ5259001	1	PAPER INDICATOR	
1-11	UL9092001	1	LOCK LEVER	
1-12	UL9095001	1	RELEASE LEVER EXTENSION SPRING	
1-13	LJ4196001	1	PRESSURE ROLLER HOLDER	
1-14	LJ5260001	1	PRESSURE ROLLER COLLAR	
1-15	LJ5261001	1	PRESSURE ROLLER SHAFT	
1-16	LJ4197001	1	PAPER TRAY COVER	
1-17	LJ4272001	1	TRAY COVER FILM	
1-18	LJ4221001	1	SCRATCH SPONGE HOLDER ASSY	
1-19	LJ4200001	2	SCRATCH SPONGE SPRING	
1-20	LJ5011001	1	TRAY LOCK LEVER	
1-21	UL9083001	1	PAPER REAR GUIDE	
1-22	UU0231001	1	TAPTITE, PAN B M3X8	
1-23	087310815	1	TAPTITE, CUP B M3X8	
1-24	UF8709001	1	TAPTITE, TORX PAN B M3X8	

MODEL HL-1650/1670N 84U-Z21/Z22-045/046

T/I No. PR2001032 / PR2001135

6. FIXING UNIT

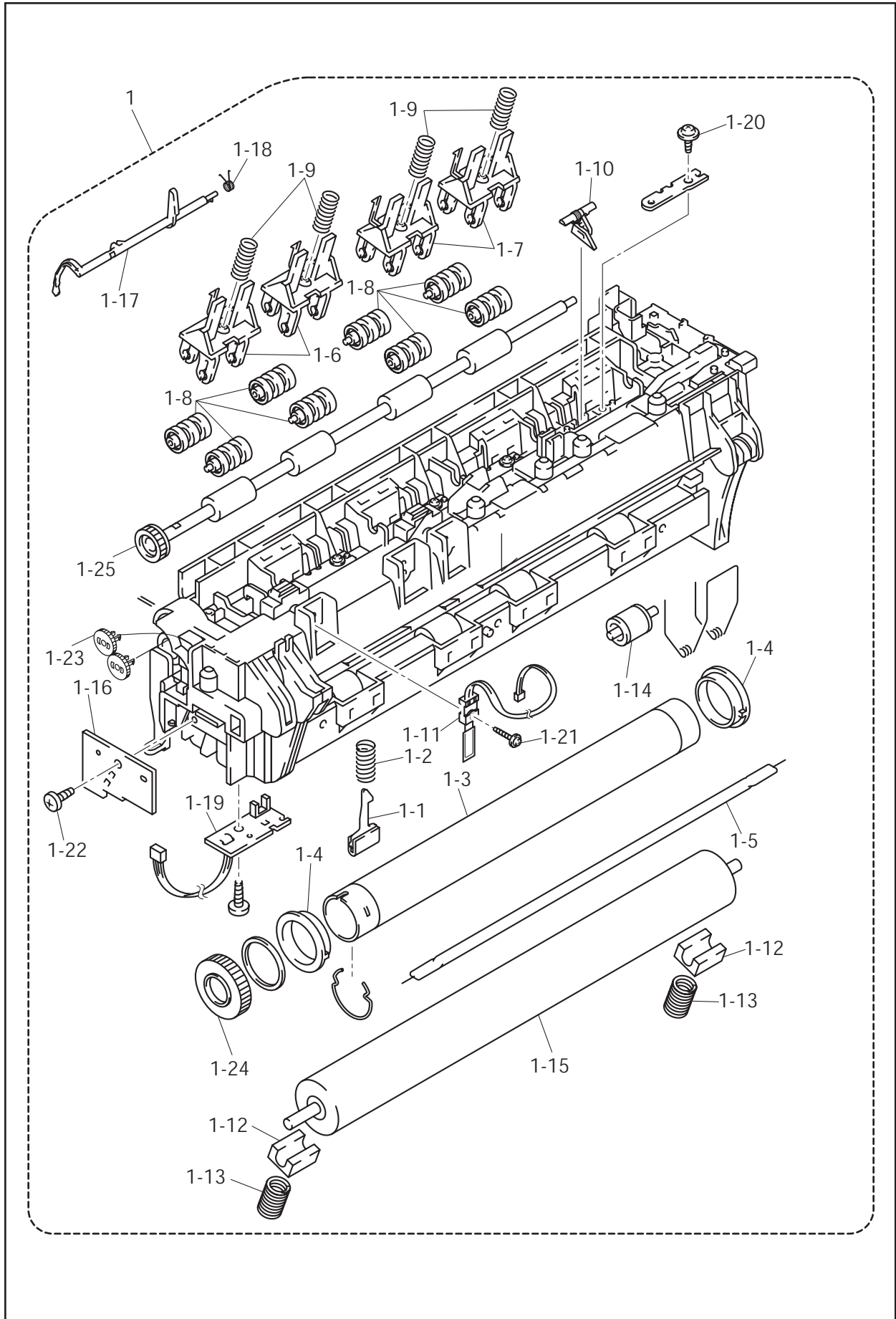

MODEL HL-1650/1670N 84U-Z21/Z22-050/051

6. FIXING UNIT

REF.NO.	CODE	Q'TY	DESCRIPTION	REMARK
1	LJ7747001	1	FIXING UNIT, 115V (SP)	chg
1	LJ7753001	1	FIXING UNIT, 230V (SP)	chg
1-1	LJ5621001	1	CLEANER ASSY H	
1-2	UH3635001	1	CLEANER SPRING 30	
1-3	LJ7748001	1	HEAT ROLLER 25	chg
1-4	UL8908001	2	HR BEARING 25	
1-5	LJ5274001	1	HALOGEN LAMP, 115V	
1-5	LJ5351001	1	HALOGEN LAMP, 230V	
1-6	LJ5276001	2	EJECT PINCH ROLLER HOLDER L	
1-7	LJ5277001	2	EJECT PINCH ROLLER HOLDER R	
1-8	LJ5540001	8	EJECT PINCH ROLLER F	
1-9	LJ5279001	4	EJECT PINCH SPRING	
1-10	LJ7750001	4	PICK OFF FINGER ASSY 3	chg
1-11	LJ7749001	1	THERMISTOR ASSY	chg
1-12	UL8916001	2	PR BEARING	
1-13	LJ5286001	2	PR SPRING	
1-14	LJ5268001	5	CLEANER PINCH ROLLER ASSY	
1-15	LJ5287001	1	PRESSURE ROLLER 25	
1-16	LJ8356001	1	THERMISTOR RELAY PCB ASSY	
1-17	LJ5289001	1	PAPER EJECT ACTUATOR	
1-18	LJ5066001	1	EJECT ACTUATOR SPRING	
1-19	LJ8366001	1	EJECT SENSOR PCB ASSY	
1-20	087310615	1	TAPTITE, CUP B M3X6	
1-21	087311215	1	TAPTITE, CUP B M3X12	
1-22	085311015	1	SCREW, BIND B TITE 3X10	
1-23	LM2047001	2	IDLE GEAR 13	chg
1-24	UL8910001	1	HR GEAR 34	add
1-25	LJ4118001	1	EJECT ROLLER ASSY	ADD

MODEL HL-1650/1670N 84U-Z21/Z22-050/051

7. COVERS

REF.NO.	CODE	Q'TY	DESCRIPTION	REMARK
1	LJ5004001	1	SIDE COVER R	
2	LJ5630001	1	SIDE COVER L ASSY	
3	LJ5291001	1	PAPER STOPPER	
4	LJ5599001	1	PAPER STOPPER S	
5	LJ5293001	1	TOP COVER	
6	LJ5294001	1	PANEL COVER ASSY	
6-1	LJ5295001	1	PANEL COVER	
6-2	LJ5296001	1	PANEL LIGHT GUIDE	
6-3	LJ5297001	1	KEY	
6-4	LJ5298001	1	KEY TOP A	
6-5	LJ5299001	1	KEY TOP B	
6-6	LJ8361001	1	PANEL PCB ASSY	
6-7	LJ5301001	1	LCDLMG161S6-TPT	
6-8	LJ8362001	1	BACK LIGHT PCB ASSY	
6-9	LJ5073001	1	DIFFUSION FILM	
6-10	LJ5302001	1	LCD HOLDER	
6-11	087310815	3	TAPTITE, CUP B M3X8	
6-12	087311015	3	TAPTITE, CUP B M3X10	
7	LJ5006001	1	ACCESS COVER	
8	LJ5007001	1	REAR COVER R	
9	LJ5008001	1	REAR COVER L	
10	LJ5030001	1	BROTHER EMBLEM	
11	LJ5472001	1	PRINTED LCD COVER ASSY 1650	
11	LJ5467001	1	PRINTED LCD COVER ASSY 1670N	
11	LJ5563001	1	PRINTED LCD COVER ASSY OEM	add
12	LJ0908001	1	LASER CAUTION LABEL B	CHG
13	LJ5306001	1	HEATER CAUTION LABEL REAR	
14	LJ5575001	1	MYLAR LABEL 1650 FRONT (US)	
15	LJ5576001	1	MYLAR LABEL 1650 A (US)	
16	UH0905001	1	PATENT LABEL (US)	
16	LJ4421001	1	MARKING LABEL N/S (Norway/Sweden)	
16	LJ4541001	1	HOT LINE LABEL (Swiss)	
16	UH3297001	1	C-TICK MARK (Australia)	
17	UF9823001	6	SHOULDER SCREW	
18	LJ5013001	1	PROCESS UNIT COVER ASSY	add

MODEL HL-1650/1670N 84U-Z21/Z22-060/061

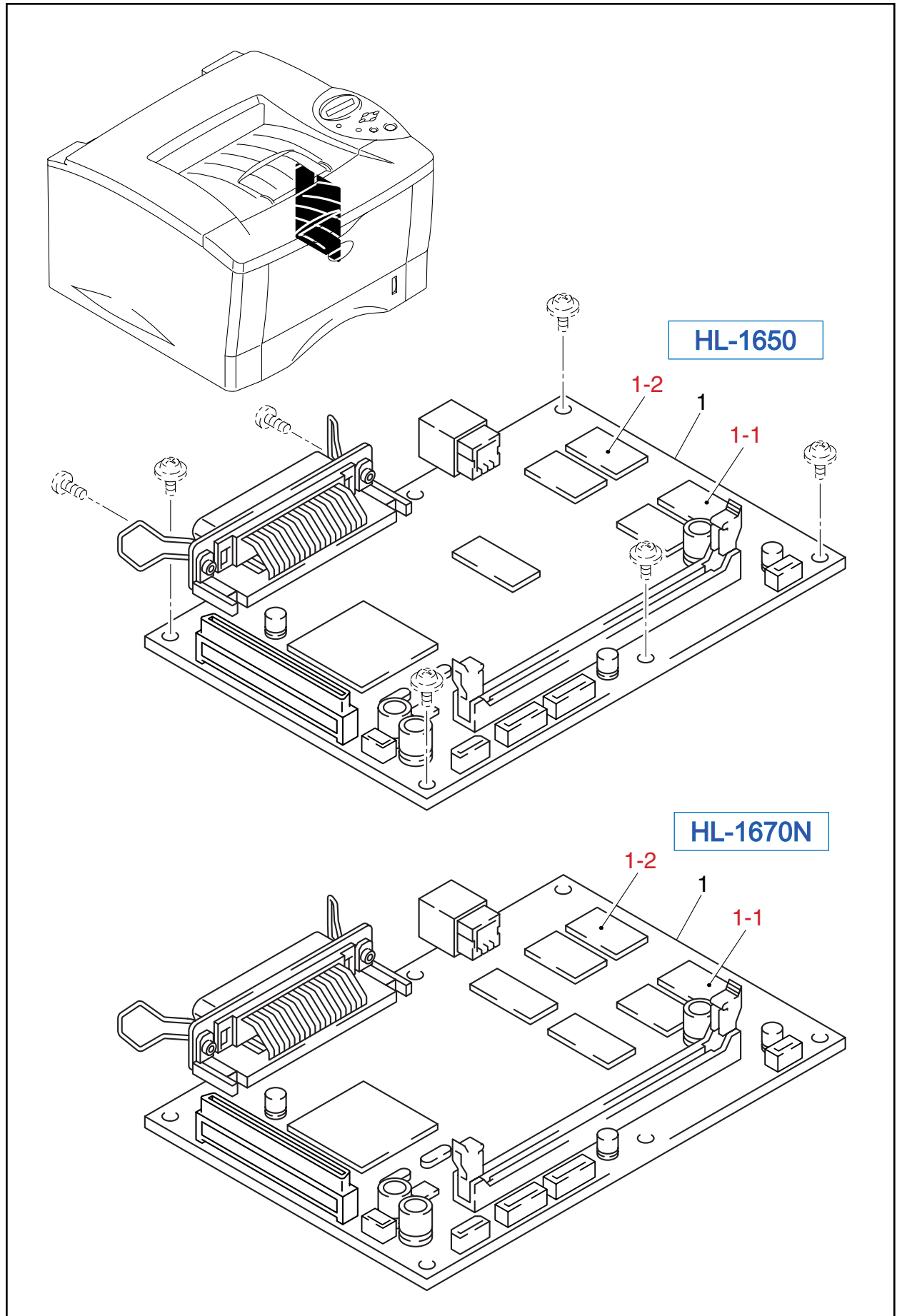

MODEL HL-1650/1670N 84U-Z21/Z22-101

T/I NO. PR2001071

8. MAIN PCB

REF.NO.	CODE	Q'TY	DESCRIPTION	SYMBOL	REMARK
1	LJ8451001	1	MAIN PCB ASSY 1650 (US)	B512078-400L	chg
1	LJ8451005	1	MAIN PCB ASSY 1650 (EU)	B512078-407L	chg
1	LJ8451008	1	MAIN PCB ASSY 1650 (ISRAEL)	B512078-401L	chg
1	LJ8650001	1	MAIN PCB ASSY 1670N (US)	B512078-420J	chg
1	LJ8650005	1	MAIN PCB ASSY 1670N (EU)	B512078-427J	chg
1	LJ8650008	1	MAIN PCB ASSY 1670N (ISRAEL)	B512078-421J	chg
1	LJ9349001	1	MAIN PCB ASSY ZLH FLASH	B512078-430Z	ADD
1-1	LJ8865001	1	MASK ROM: MX23L6411TC-12 1650L		chg
1-2	LJ8866001	1	MASK ROM: MX23L6411TC-12 1650H		chg

MODEL HL-1650/1670N 84U-Z21/Z22-101

9. ENGINE PCB

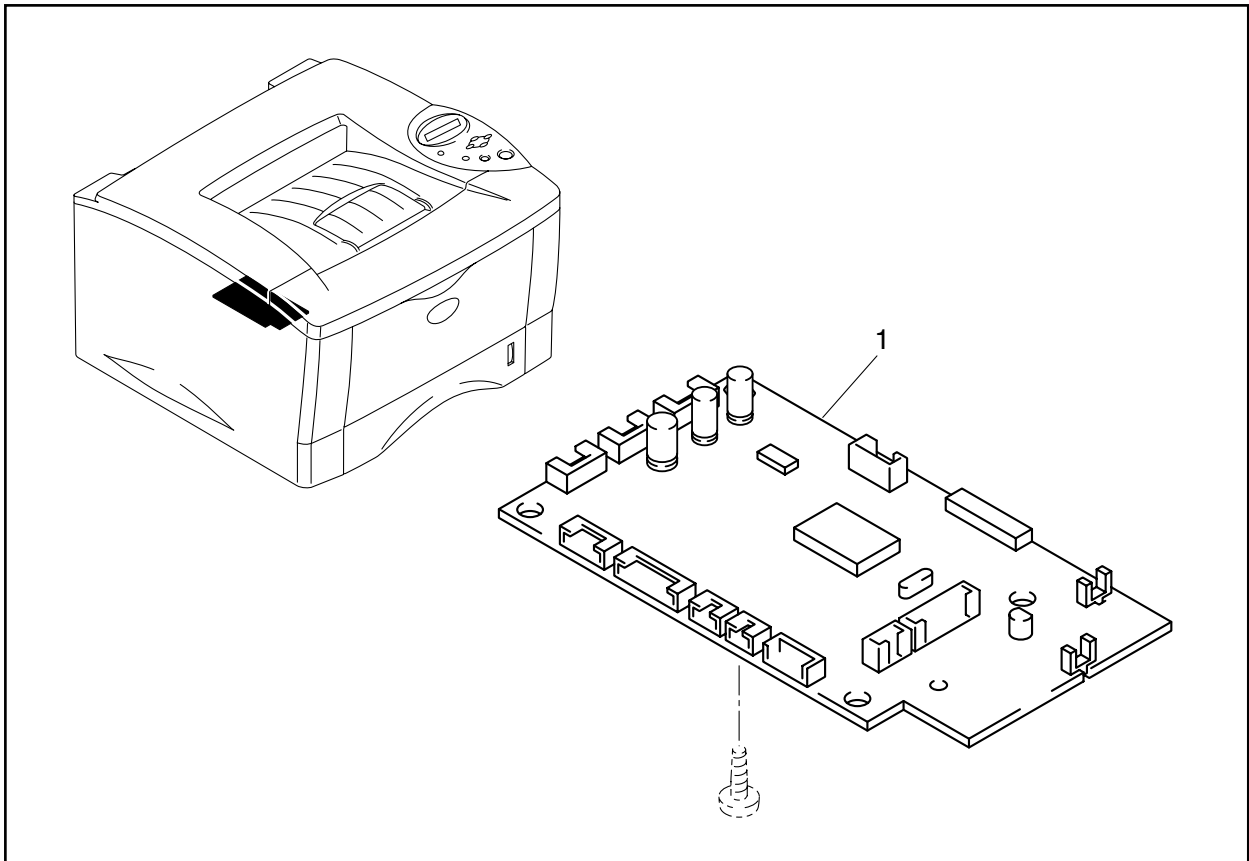

MODEL HL-1650/1670N 84U-Z21/Z22-151

10. LOW-VOLTAGE POWR SUPPLY PCB

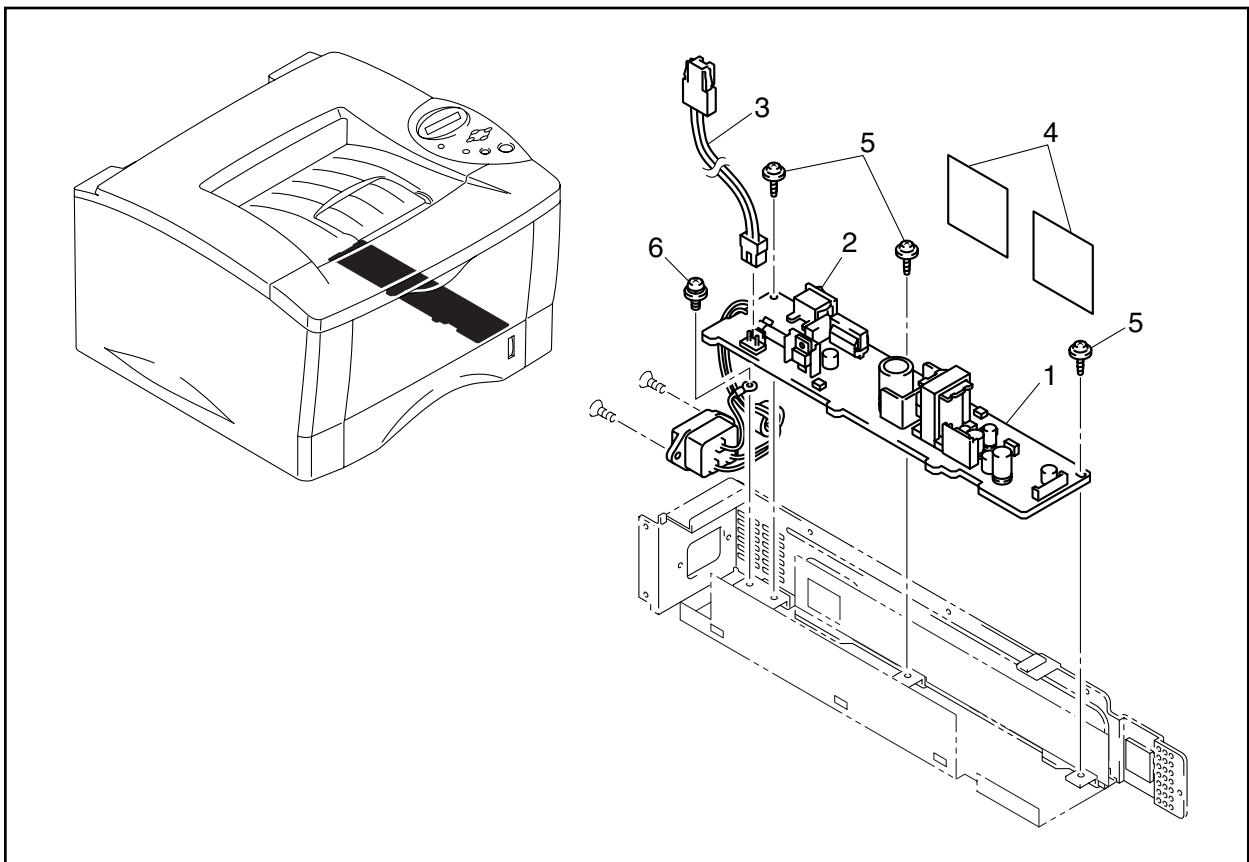

MODEL HL-1650/1670N 84U-Z21/Z22-200/201

9. ENGINE PCB

REF.NO.	CODE	Q'TY	DESCRIPTION	SYMBOL	REMARK
1	LJ8355001	1	ENGINE PCB ASSY 1650	B512079-200C	

MODEL HL-1650/1670N 84U-Z21/Z22-151

10. LOW-VOLTAGE POWER SUPPLY PCB

REF.NO.	CODE	Q'TY	DESCRIPTION	REMARK
1	LJ8388001	1	PS PCB ASSY ZLH, 115V	
1	LJ8389001	1	PS PCB ASSY ZLH, 230V	
2	LJ8424001	1	POWER SWITCH RIGHT ANGLE	
3	LJ8391001	1	INLET HARNESS ASSY, 115V	
4	LJ8723001	2	TAPE 50X40	
5	087320615	3	SCREW, CUP S TITE 3X6	
6	LM2048001	1	SCREW, PAN M3.5X6 (S/P WASHER)	CHG

MODEL HL-1650/1670N 84U-Z21/Z22-200/201

11. HIGH-VOLTAGE POWER SUPPLY PCB

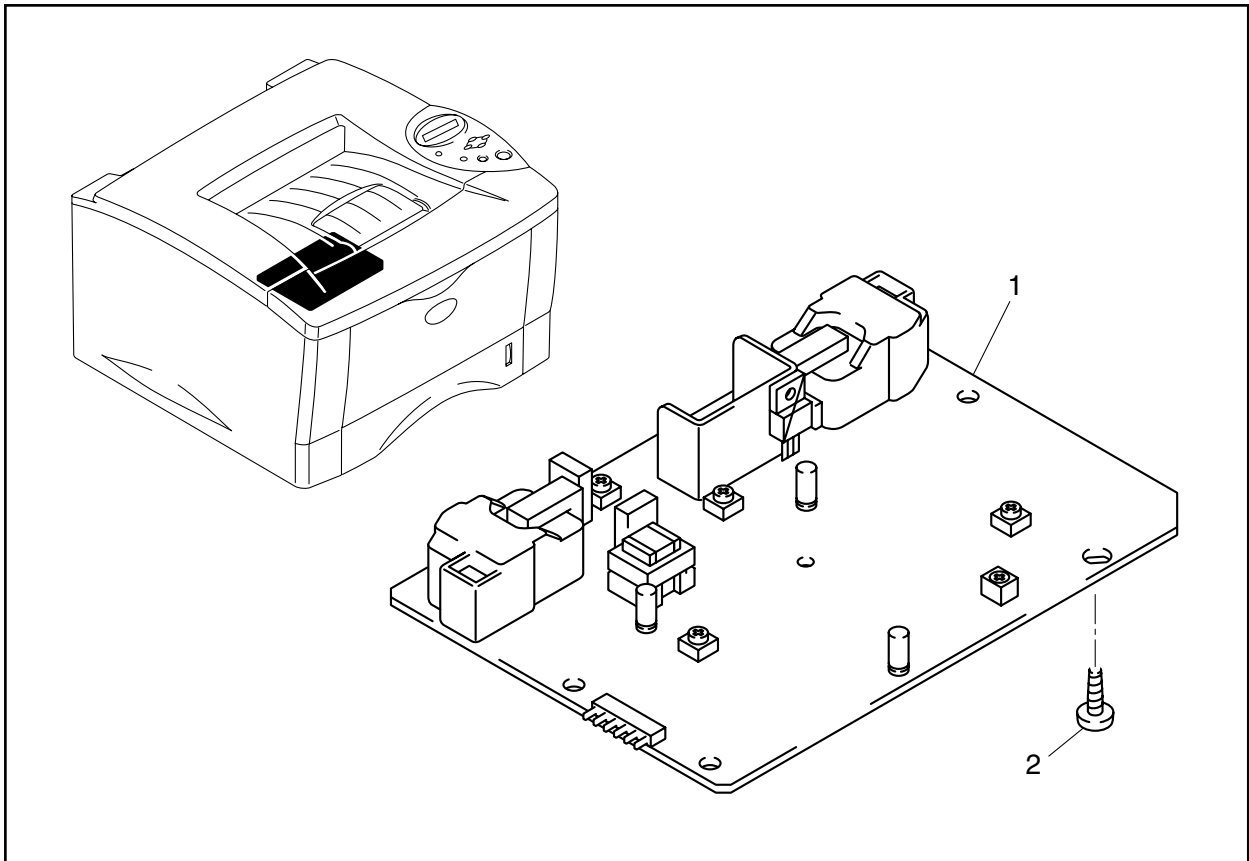

MODEL HL-1650/1670N 84U-Z21/Z22-220

12. AC CORDS

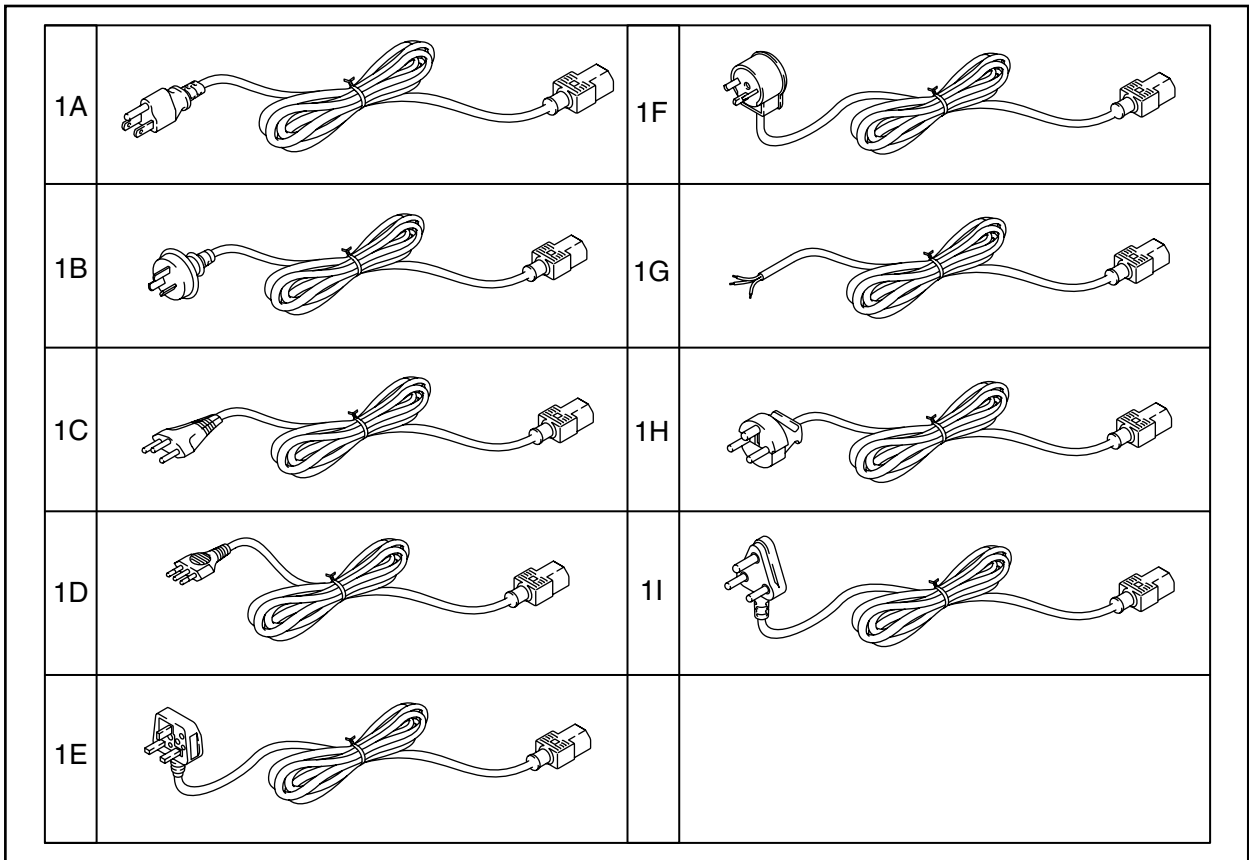

MODEL HL-1650/1670N 84U-Z21/Z22-230

11. HIGH-VOLTAGE POWER SUPPLY PCB

REF.NO.	CODE	Q'TY	DESCRIPTION	REMARK
1	LJ8422001	1	HIGH-VOLTAGE PS PCB ASSY ZLH	
2	085411015	1	TAPTITE, BIND B M4X10	

MODEL HL-1650/1670N 84U-Z21/Z22-220

12. AC CORDS

REF.NO.	CODE	Q'TY	DESCRIPTION	REMARK
1A	LJ8875001	1	AC CORD, UL/CSA	chg
1B	LJ9666001	1	AC CORD LF, SAA	CHG
1C	LJ8877001	1	AC CORD ASSY, SEV	chg
1D	UK4099001	1	AC CORD, CHLI	
1E	UH1054001	1	AC CORD, BS	
1F	U34322001	1	AC CORD #6, ISRAEL	
1G	UK4094001	1	AC CORD, DEMKO	
1H	LJ8876001	1	AC CORD ASSY, VDE	chg
1I	LJ8288001	1	AC CORD ASSY, SOUTH AFRICA	

MODEL HL-1650/1670N 84U-Z21/Z22-230

13. ACCESSORIES

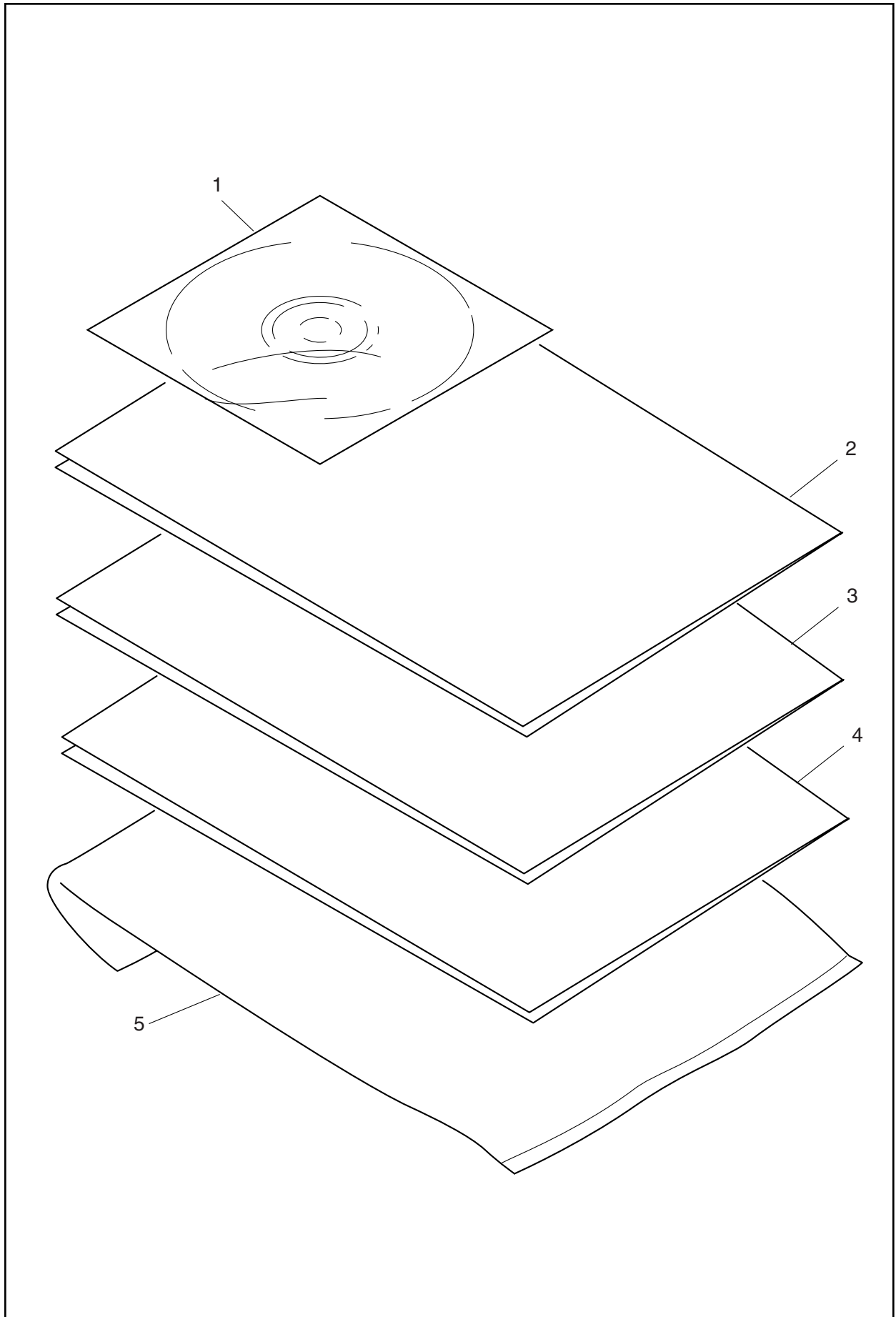

MODEL HL-1650/1670N 84U-Z21/Z22-920

13. ACCESSORIES

PR2001138

REF.NO.	CODE	Q'TY	DESCRIPTION	REMARK
1	LJ5024001	1	CD ASSY 1650/1670N	
2	LJ5025001	1	SET GUIDE, US	
2	LJ5414001	1	SET GUIDE, FRA	
2	LJ5353001	1	SET GUIDE, GER	
2	LJ5424001	1	SET GUIDE, NOR	
2	LJ5429001	1	SET GUIDE, NL	
2	LJ5438001	1	SET GUIDE, DEN	
2	LJ5443001	1	SET GUIDE, SPA	
2	LJ5448001	1	SET GUIDE, ITA	
2	LJ5453001	1	SET GUIDE, SWE	
3	LJ5404001	1	SOFT GUIDE, US	
3	LJ5415001	1	SOFT GUIDE, FRA	
3	LJ5405001	1	SOFT GUIDE, GER	
3	LJ5425001	1	SOFT GUIDE, NOR	
3	LJ5430001	1	SOFT GUIDE, NL	
3	LJ5439001	1	SOFT GUIDE, DEN	
3	LJ5444001	1	SOFT GUIDE, SPA	
3	LJ5449001	1	SOFT GUIDE, ITA	
3	LJ5454001	1	SOFT GUIDE, SWE	
4	LJ1047001	1	NETWORK SET UP GUIDE, US	CHNG
4	LJ1049001	1	NETWORK SET UP GUIDE, FRA	CHNG
4	LJ1048001	1	NETWORK SET UP GUIDE, GER	CHNG
4	LJ1054001	1	NETWORK SET UP GUIDE, NOR	CHNG
4	LJ1050001	1	NETWORK SET UP GUIDE, NL	CHNG
4	LJ1051001	1	NETWORK SET UP GUIDE, DEN	CHNG
4	LJ1052001	1	NETWORK SET UP GUIDE, SPA	CHNG
4	LJ1053001	1	NETWORK SET UP GUIDE, ITA	CHNG
4	LJ1055001	1	NETWORK SET UP GUIDE, SWE	CHNG
5	LJ4961001	1	BAG, 215X350H	

MODEL HL-1650/1670N 84U-Z21/Z22-920

T/I NO. PR2001138

14. PACKING MATERIALS

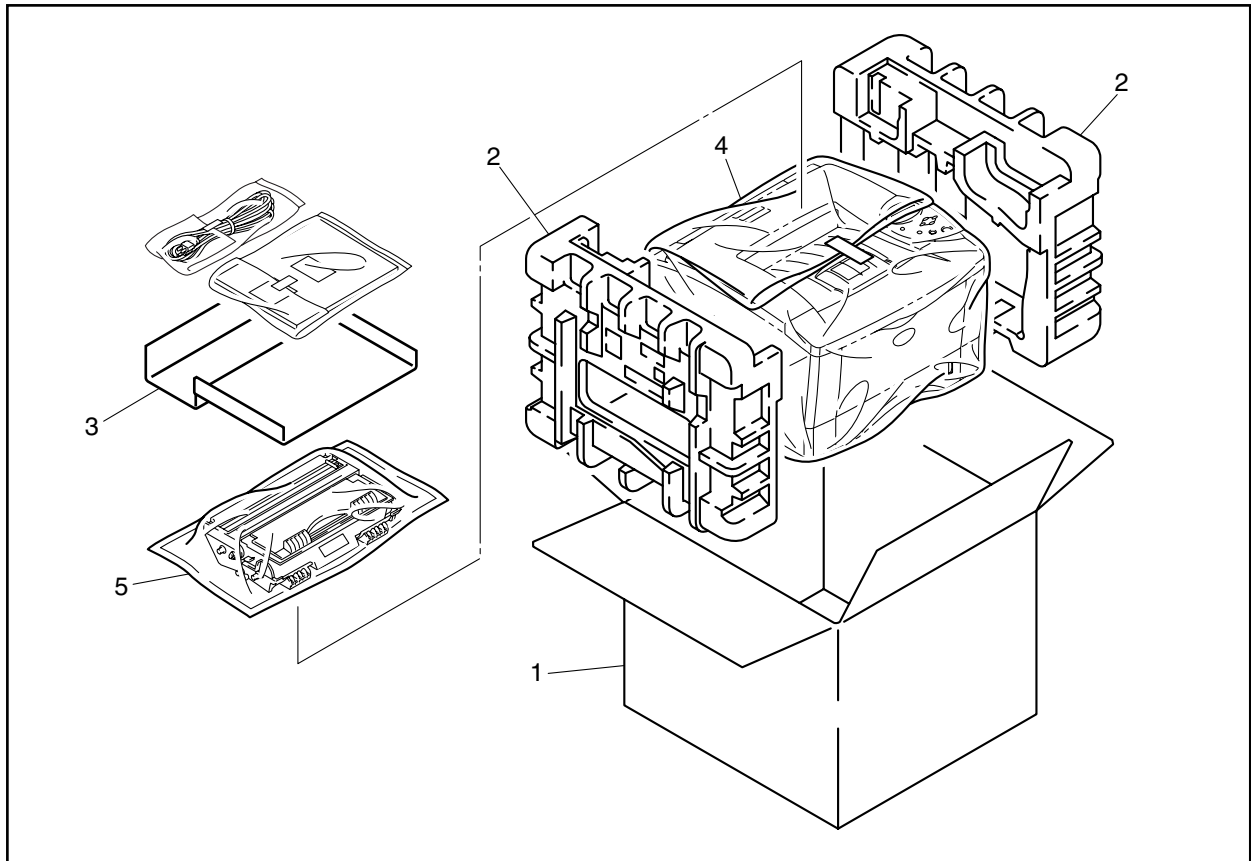

MODEL HL-1650/1670N 84U-Z21/Z22-930

15. NETWORK BOARD

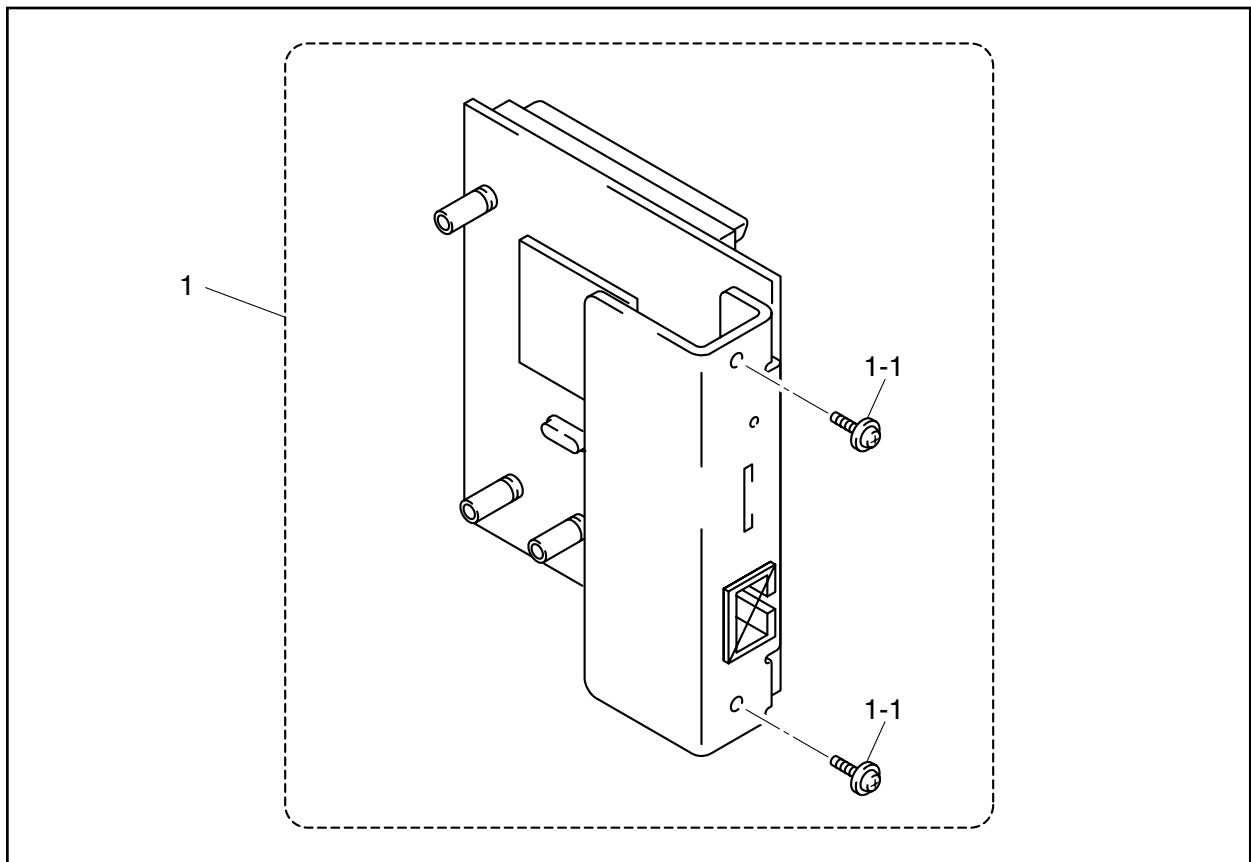

MODEL HL-1670N 84U-Z22

14. PACKING MATERIALS

PR2001120

REF.NO.	CODE	Q'TY	DESCRIPTION	REMARK
1	LL0329001	1	CARTON, HL-1650 US OSS	
1	LL0322001	1	CARTON, HL-1670N US	
1	LL0317001	1	CARTON, HL-1650 CANADA	
1	LL0318001	1	CARTON, HL-1650 EUR	
1	LL0323001	1	CARTON, HL-1670N EUR	
1	LL0050001	1	CARTON, OEM	
1	LL0281001	1	CARTON	
2	LL0282001	1	STYROFORM PAD ASSY	
3	LL0280001	1	CARTON FOR ACCESSORIES	
4	LJ5583001	1	BAG, 800X900H	
5	LJ5557001	1	PROCESS BAG 400X480	

MODEL HL-1650/1670N 84U-Z21/Z22-930

T/I NO. PR2001066 / PR2001120

15. NETWORK BOARD

REF.NO.	CODE	Q'TY	DESCRIPTION	SYMBOL	REMARK
1	LJ8671001	1	BRNET PCB UNIT 4100H	B512058-211A	
1-1	087320616	2	TAPTITE, CUP S M3X6		

MODEL HL-1670N 84U-Z22

16. PERIODICAL MAINTENANCE PARTS

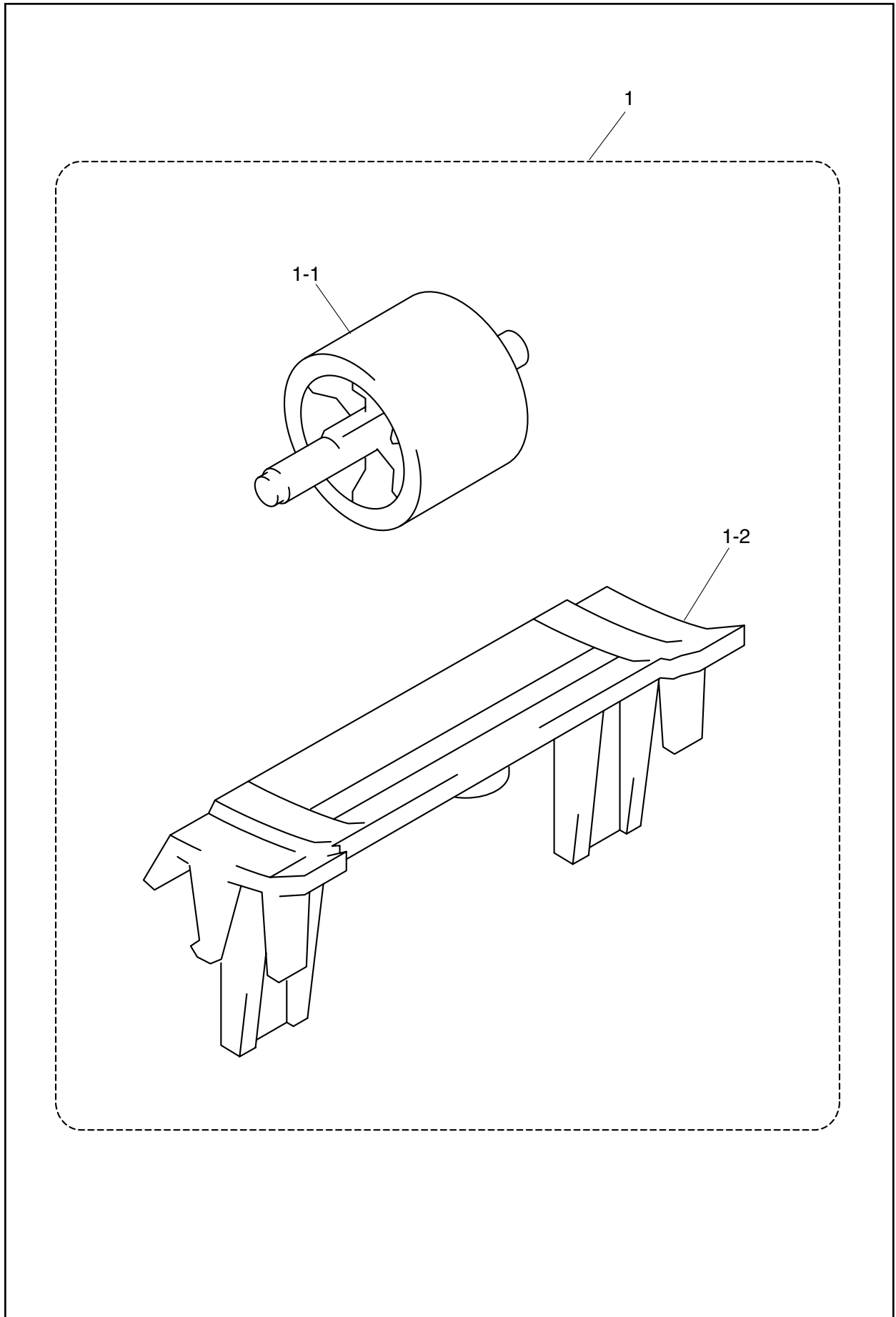

MODEL HL-1650/1670N 84U-Z21/Z22

16. PERIODICAL MAINTENANCE PARTS

REF.NO.	CODE	Q'TY	DESCRIPTION	REMARK
1	LJ5615001	1	PAPER FEEDING KIT	
1-1	LJ5016001	1	PAPER PICK-UP ROLLER ASSY *1	
1-2	LJ5256001	1	PAD HOLDER ZLH ASSY *2	
			*1 Refer to "3. PAPER FEEDER / MP UNIT".	
			*2 Refer to "5. PAPER CASSETTE".	

MODEL HL-1650/1670N 84U-Z21/Z22