



FS-1016MFP

PARTS LIST

Published in February 2006

2G4PL070

842G4120

First Edition

NOTES

1. Indicate parts number and machine model when placing an order.

e.g.	Parts Number	Parts Name	Machine Model	Cycle	Quantity
	302G404020	COVER LID	FS-1016MFP	50Hz/60Hz	1

2. Service calls and freight will be charged separately.

3. Symbols in the "Parts Number" column.

- Parts with "•" are component parts or sub-assemblies of the assembly appearing immediately above them.

e.g.	Parts Number	Parts Name	Parts Number	Parts Name
	302FV93080	CT-110	•2DC07010	STOPPER PAPER
			•2DC07020	POSITIONING FOLIO PAPER

- Parts with "••" are component parts or sub-assembly with "•" appearing immediately above them.

e.g.	Parts Number	Parts Name	Parts Number	Parts Name
	•302G470030	UNIT HOUSING BOTTOM	••302G470040	UNIT BELT
			••302G470190	BUTTON, RELEASE

- Parts with "⊙" indicates the spare parts and the parts without "⊙" can not be supplied.

CONTENTS

FIG. 1	Covers	2
FIG. 2	Frames I	4
FIG. 3	Frames II	6
FIG. 4	Paper Cassette	8
FIG. 5	Driving Unit	10
FIG. 6	Imaging Unit	12
FIG. 7	Developer Unit	14
FIG. 8	Fuser Unit	16
FIG. 9	MFP Unit	18
FIG. 10	Accessories & Parts Package	20
	• INDEX	22

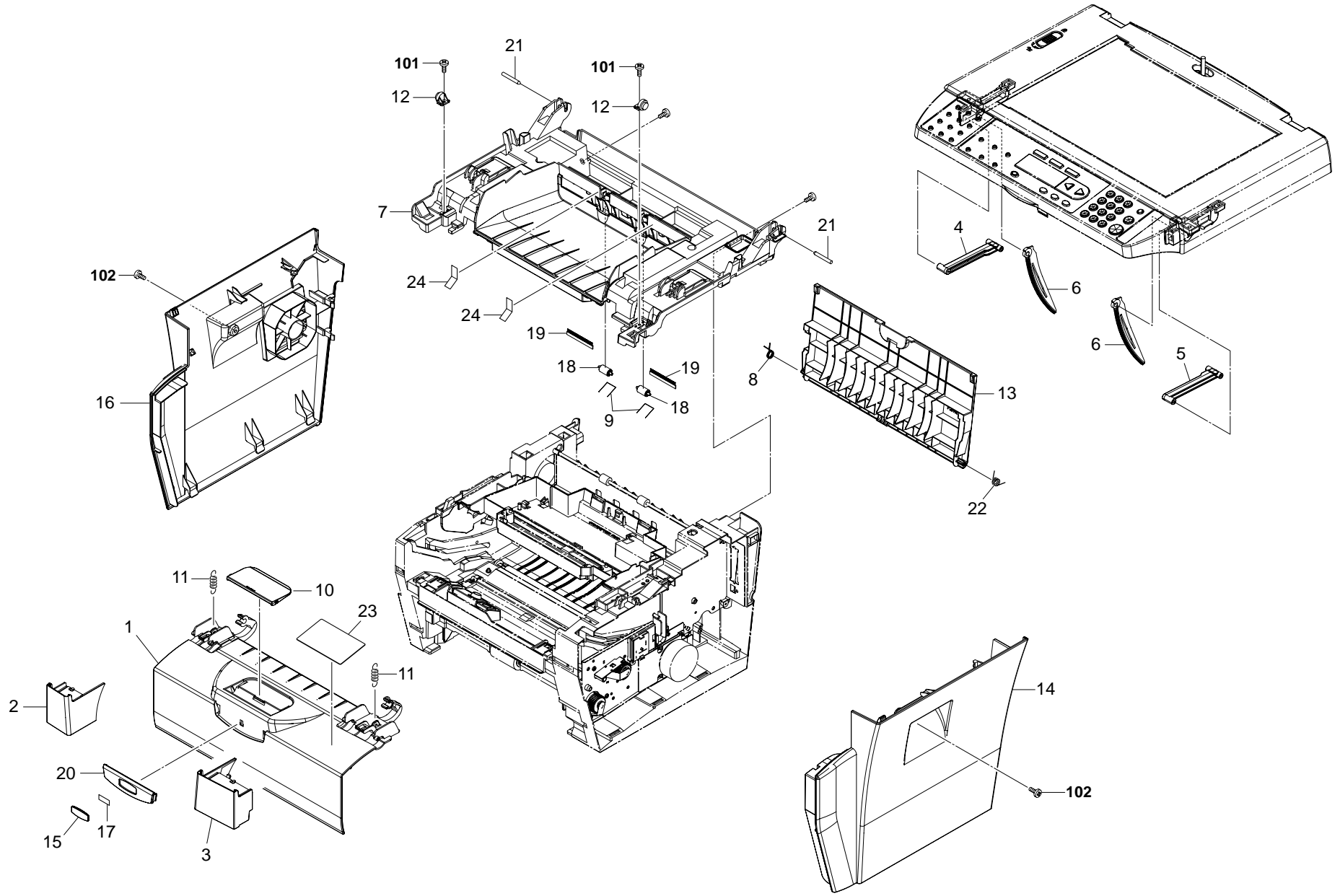

FIG. 1 Covers

2G4

SP	Ref. No.	Part.No.	Alternative.	Description	Quantity	
					120	230
⊙	1	302G404020	2G404020	COVER LID	1	1
	2	302G404070	2G404070	ARM LID L	1	1
	3	302G404080	2G404080	ARM LID R	1	1
	4	302G404090	2G404090	LINK LIFT L	1	1
	5	302G404100	2G404100	LINK LIFT R	1	1
	6	302G404110	2G404110	GEAR ARM DAMPING	2	2
⊙	7	302G404010	2G404010	COVER TOP PRINTER	1	1
	8	5MMW126SD001	2FV04130	SPRING COVER REAR	1	1
	9	302G404060	2G404060	SPRING PULLEY FD	2	2
	10	302G404050	2G404050	TRAY SUBTRAY	1	1
	11	302G404150	2G404150	SPRING ARM	2	2
	12	302G404160	2G404160	DAMPER	2	2
⊙	13	5MVB874SB011	2FV04060	COVER REAR	1	1
⊙	14	302G404040	2G404040	COVER SIDE R	1	1
	15	302F904120	2F904120	EMBLEM KYOCERA	1	1
⊙	16	302G404030	2G404030	COVER SIDE L	1	1
	17	302F904130	2F904130	TAPE EMBLEM	1	1
⊙	18	5MVM363DB001	2FV04150	PULLEY FD	2	2
	19	5MVS625XF001	2FV04140	DISCHARGER FD	2	2
	20	302G404140	2G404140	PLATE LOGOTYPE	1	1
	21	302G404130	2G404130	PIN PIVOT OD=4 L=20	2	2
	22	302FV04200	2FV04200	SPRING COVER REAR R	1	1
	23	302G404380	2G404380	LABEL LID OPERATION	1	1
	24	302G404450	2G404450	SHEET FD	2	2

SP	Ref. No.	Part.No.	Alternative.	Description	Quantity	
					120	230
	101	5MBTPB3008PW++R	B1A63080	BIND T.T SCREW(+)/ M3 X 8		
	102	5MBTPB3012PW++R	B1A63120	BIND T.T SCREW(+)/ M3 X 12 CRFREE P-T		

- Parts with "•" are component parts or sub-assemblies of the assembly appearing immediately above them.
- Parts with "⊙" indicates the spare parts.

- Parts with "••" are component parts or sub-assembly with "•" appearing immediately above them.

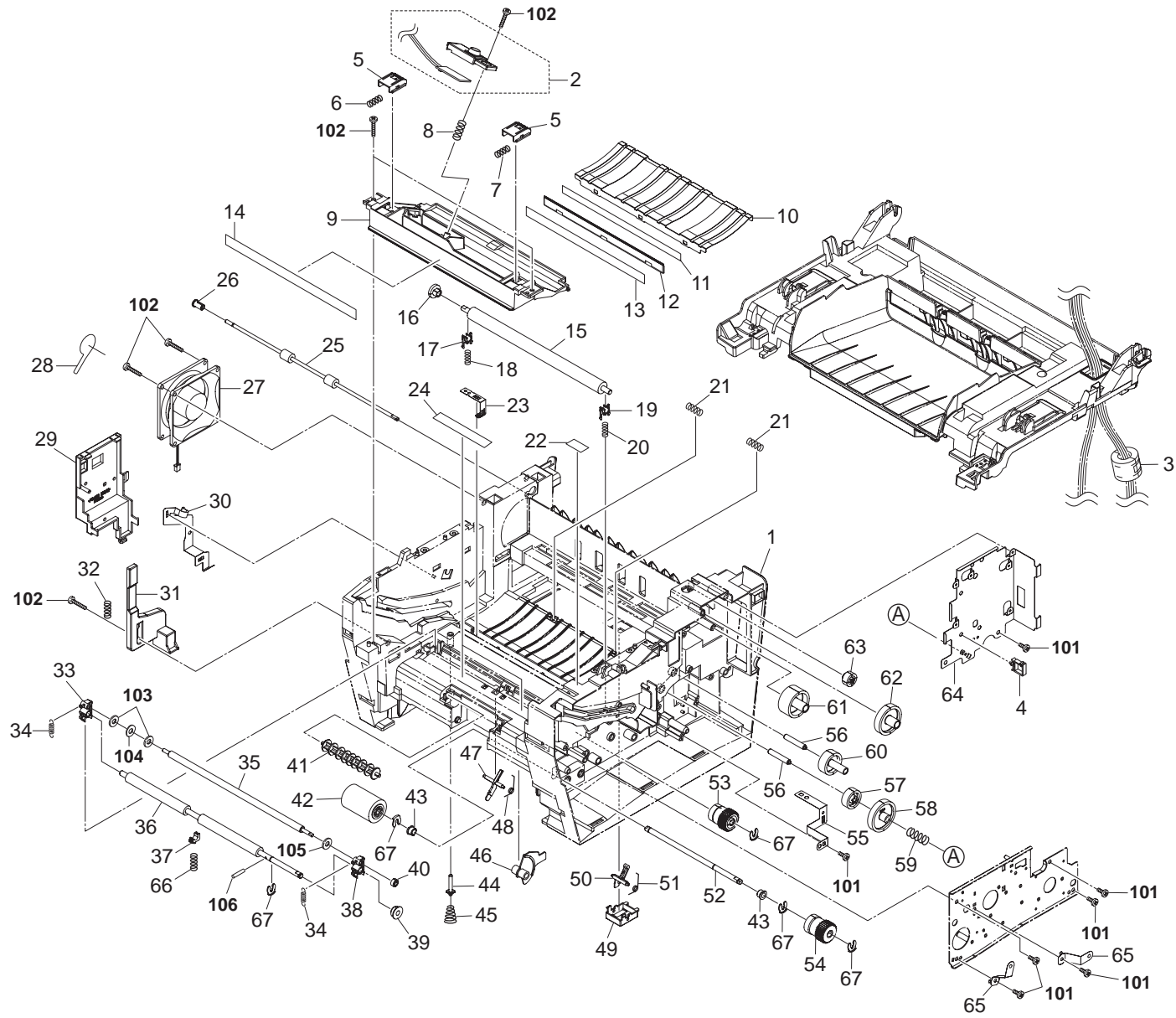

FIG. 2 Frames I

2G4

SP	Ref. No.	Part.No.	Alternative.	Description	Quantity	
					120	230
⊙	1	5MVX888CB001	2FV02170	FRAME BASE	1	1
	2	302FV00030	2FV00030	TE SENSOR ASSY	1	1
	3	M70CA010		FERRITE CORE,SFT-72SN(TAKEUCHI)	1	1
	4	7YZM610003++H01	YZ010250	ACCESS SADDLE	1	1
	5	5MVX431DN005	2FV02100	LEVER LOCK DLP	2	2
	6	5MMW261LD067	2FV02270	SPRING LEVER LOCK L	1	1
	7	5MMW261LD068	2FV02280	SPRING LEVER LOCK R	1	1
	8	5MMW261LD036	2A814570	SPRING TE SENSOR	1	1
	9	5MVX865SB008	2FV02160	GUIDE FEED	1	1
	10	5MMU862SL001	2FV02250	PLATE EARTH GUIDE	1	1
	11	5MVS812XF003	2A816120	TAPE BRUSH	1	1
	12	5MMS821LD014	2A816080	BRUSH DISCHARGER	1	1
	13	5MVS812KF006	2A816090	SHEET DISCHARGER	1	1
	14	302G402030	2G402030	LABEL JAM OPERATION	1	1
⊙	15	5MMT876SN104	2FV02230	ROLLER TRANSFER	1	1
⊙	16	5MVG127DN131	2FV02030	GEAR TC Z17	1	1
⊙	17	5MVX221DB023	2A816020	BUSH TC L	1	1
⊙	18	302G622010	2G622010	SPRING TC L	1	1
⊙	19	5MVX221DW008	2A816030	BUSH TC R	1	1
⊙	20	302FV02490	2FV02490	SPRING TC R	1	1
	21	302FV02480	2FV02480	SPRING ROLL	2	2
	22	302FV14500	2FV14500	LABEL GUIDE DLP	1	1
	23	5MMX331LD005	2FV02330	PLATE CONTACT TC	1	1
⊙	24	5MVS721KF007	2FV02390	SHEET REGIST	2	2
	25	5MMT875SN016	2FV02220	ROLLER FD	1	1
⊙	26	302FV02470	2FV02470	BUSH FD	1	1
	27	302FV45010	2FV45010	FAN MOTOR	1	1
	28	302FV02500	2FV02500	SHEET FAN	1	1
	29	5MVB763CB001	2FV02010	COVER MC	1	1
	30	5MMX763LD007	2FV02370	PLATE CONTACT MC	1	1
	31	5MVX763SB011	2FV02150	ROD INTERLOCK	1	1
	32	5MMW451LD001	2B700570	SPRING INTERLOCK	1	1
⊙	33	5MVX221DB019	2A806420	BUSH REGIST LEFT	1	1
⊙	34	5MMW261LD023	2A806410	SPRING REGIST R	2	2
	35	302A806051	2A806051	ROLLER REGIST UP	1	1
⊙	36	5MMT876SN105	2FV02240	ROLLER REGIST LOW	1	1
⊙	37	2FM02180	5MVX221DN020	BUSH REGIST C	1	1
⊙	38	5MVX221DW006	2A806430	BUSH REGIST RIGHT	1	1
⊙	39	5MVG127DB047	2A806230	GEAR REGIST Z20	1	1
⊙	40	5MVG126DB025	2A806240	GEAR REGIST Z13	1	1
⊙	41	5MVM776DB001	2FV02090	PULLEY FEED	1	1
⊙	42	5AAVR0LL+044	2A806010	ROLLER FEED ASSY	1	1
	43	5MVM176DN016	2BR20170	BUSH A	2	2
	44	5MMT365SN003	2A815020	PIN CONTACT BIAS	1	1
	45	5MMW361LD028	2FV02310	SPRING PIN BIAS	1	1
	46	5MVX552DB001	2FV02130	ACTUATOR EMPTY	1	1
⊙	47	5MVX441SB006	2FV02110	ACTUATOR REGIST	1	1
	48	5MMW261LD066	2FV02260	SPRING ACTUATOR	1	1
	49	5MVX432SB014	2FV02460	BKT ACTUATOR EXIT	1	1
⊙	50	5MVX442SB011	2FV02120	ACTUATOR EXIT	1	1

SP	Ref. No.	Part.No.	Alternative.	Description	Quantity	
					120	230
⊙	51	5MMW261LD069	2FV02290	SPRING EXIT	1	1
	52	5MMT766SN011	2FV02210	SHAFT FEED	1	1
⊙	53	5AAVCLTCH032	2FV02180	CLUTCH REGIST	1	1
⊙	54	5AAVCLTCH028	2BY02020	CLUTCH FEED	1	1
	55	5MMX643LD006	2FV02360	PLATE EARTH B	1	1
⊙	56	5MMT463SN002	2FV02200	PIN DRIVE	2	2
⊙	57	5MVG138DN088	2FV02040	GEAR FREE Z28S	1	1
⊙	58	5MVG158DN059	2FV02060	GEAR FREE Z46H	1	1
	59	5MMW371LD006	2FV02320	SPRING FREE	1	1
⊙	60	5MVG148DN107	2FV02050	GEAR Z34S	1	1
⊙	61	5MVG158DN060	2FV02070	GEAR FD Z42S	1	1
⊙	62	5MVG158DN061	2FV02080	GEAR FD Z45S	1	1
⊙	63	5MVG127DN130	2FV02020	GEAR FD Z19S	1	1
	64	302G439010	2G439010	LID CONTROLLER	1	1
	65	5MMX522LD013	2FV02340	PLATE EARTH FEED	2	2
	66	2FM02580		SPRING REGIST C	1	1
	67	5MVX111DN003	2A806250	RING STOPPER	5	5
	101	5MBTPB4010WW	B8204100	BIND T.T SCREW(+)/ M4 X 10		
	102	B4B74100		+TP T.T SCREW(+)/ M4 X 10 CRFREE B-T		
	103	5MBWK41A03NN	C2891100	POLY-SLIDER WASHER 4.1X10X0.3T		
	104	5MBWW43802SP++R	C3790080	WAVE WASHER / M4X8.0X0.2T		
	105	5MBWK4165+NN	C2894650	POLY SLIDER / M4.1X6.5X0.25T		
	106	5MBP2008WWLD	E1120080	SPRING PIN / M2 X 8		

- Parts with "*" are component parts or sub-assemblies of the assembly appearing immediately above them.
- Parts with "⊙" indicates the spare parts.

- Parts with "••" are component parts or sub-assembly with "•" appearing immediately above them.

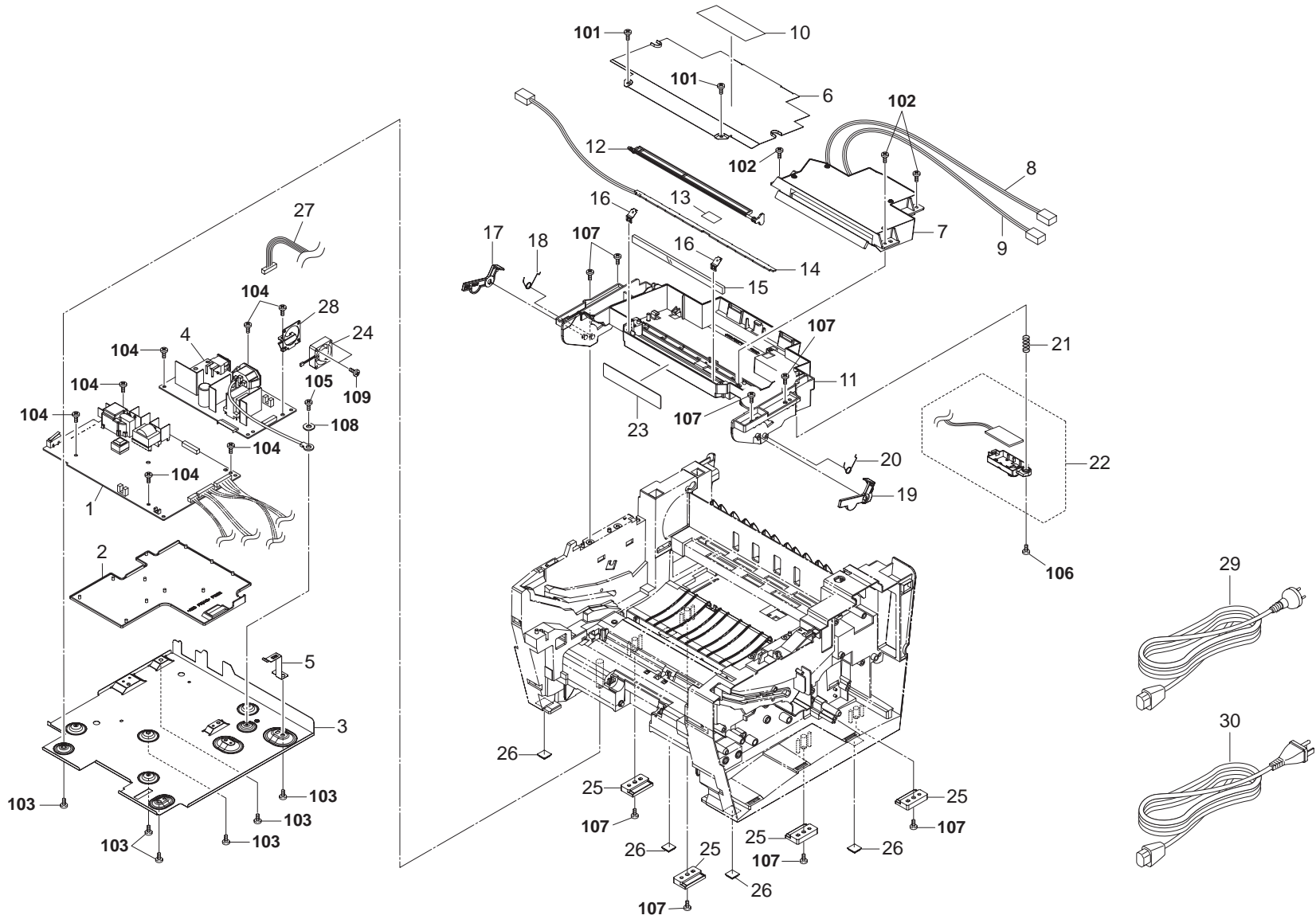

FIG. 3 Frames II

2G4

SP	Ref. No.	Part.No.	Alternative.	Description	Quantity	
					120	230
⊙	1	302G480010	2G480010	P.W.B ASSY ENGINE(SP)	1	1
	2	5MVS777CB001	2FV02000	COVER PWB	1	1
	3	5MMX884SL002	2FV02380	PLATE BOTTOM FRAME	1	1
⊙	4	302G445010	2G445010	UNIT LOW VOLTAGE 100	1	
⊙	4	302G445020	2G445020	UNIT LOW VOLTAGE 200		1
⊙	5	5MMX541LD002	2FV02350	PLATE EARTH A	1	1
	6	5MMS875SL007	2FV12020	COVER SCANNER	1	1
⊙	7	302FV93092	2FV93092	LK-110	1	1
	8	302G446010	2G446010	CONN.CORD ASSY MAIN-LSU	1	1
⊙	9	302FV26052	2FV26052	CONN CORD ASSY	1	1
	10	302FV12080	2FV12080	LABEL LASER CAUTION	1	1
⊙	11	5MVX876XB002	2FV12060	FRAME MID	1	1
	12	5MVX821SB014	2FV12050	SHUTTER LSU	1	1
⊙	13	302FV12070	2FV12070	SHEET ERASER	1	1
	14	5AAPRELC1008AHR	2FV01100	P.W.B.ASSY KP-5157	1	1
⊙	15	2DC13030		MIRROR LSU	1	1
	16	5MMX221LD034	2FV12030	SPRING MIRROR	2	2
⊙	17	5MVX631SB006	2FV02420	LEVER STOPPER L	1	1
	18	5MMW165SD001	2FV02400	SPRING STOPPER L	1	1
⊙	19	5MVX631SB007	2FV02430	LEVER STOPPER R	1	1
	20	5MMW165SD002	2FV02410	SPRING STOPPER R	1	1
⊙	21	5MMW261LD070	2FV12010	SPRING FULL SENSOR	1	1
	22	302FV00040	2FV00040	FULL SENSOR ASSY	1	1
⊙	23	302G402040	2G402040	LABE CONT OPERATION	1	1
	24	302G444020	2G444020	FAN MOTOR	1	1
⊙	25	5MVX431SB012	2FV02450	RAIL FRAME	4	4
	26	5MVX221RB014	2BS03110	FOOT	4	4
⊙	27	302G446030	2G446030	CONN.CORD ASSY LVP-MAIN	1	1
	28	302G402010	2G402010	BRACKET FAN	1	1
⊙	29	2DC27410		AC CORD ASSY	1	
	30	302FV45020	2FV45020	AC CORD ASSY		1

SP	Ref. No.	Part.No.	Alternative.	Description	Quantity	
					120	230
⊙	101	5MBTPB3008PW++R	B1A63080	BIND T.T SCREW(+)/ M3 X 8		
	102	5MBTPB3012PW++R	B1A63120	BIND T.T SCREW(+)/ M3 X 12		
⊙	103	5MBTPB4010WW	B8204100	BIND T.T SCREW(+)/ M4 X 10		
	104	BAB53060	B1A53060	+TP TAP-TITE S SCREW M3X06		
⊙	105	5MBTPB4006TW++R	B1A54060	BIND T.T SCREW(+)/ M4 X 6		
	106	BAA63080		+TP TAP-TITE P SCREW M3X08		
⊙	107	B4B74100		+TP T.T SCREW(+)/ M4 X 10 CRFREE B-T		
	108	5MBWG40854LD	CP003020	OT.LOCK WASHER / M4X8.5X0.4T		
⊙	109	5MBTPB3014TW++R	B1A53140	BIND T.T SCREW(+)/ M3 X 14 CRFREE S-T		

- Parts with "*" are component parts or sub-assemblies of the assembly appearing immediately above them.
- Parts with "⊙" indicates the spare parts.

- Parts with "••" are component parts or sub-assembly with "•" appearing immediately above them.

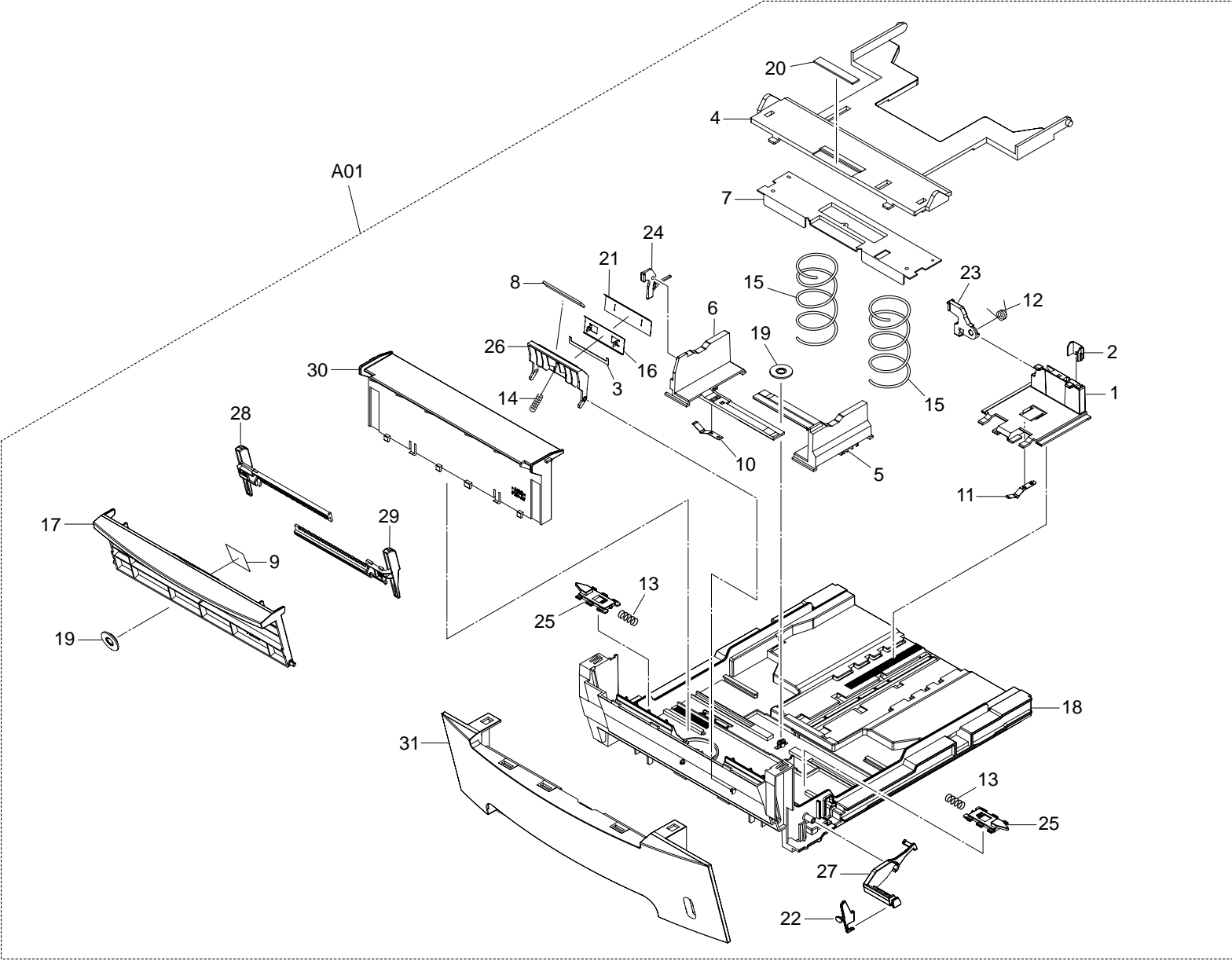

FIG. 4 Paper Cassette

SP	Ref. No.	Part.No.	Alternative.	Description	Quantity	
					120	230
⊙	A01	302FV93080	2FV93080	CT-110	1	1
	1	*2DC07010		STOPPER PAPER	1	1
	2	*2DC07020		POSITIONING FOLIO PAPER	1	1
	3	*2DC07040		FILM SEPARATOR	1	1
	4	*2FV06180		BOTTOM CASSETTE	1	1
	5	*302A807021	2A807021	GUIDE SIDE R	1	1
	6	*302A807031	2A807031	GUIDE SIDE L	1	1
	7	*302A807171	2A807171	PLATE BOTTOM	1	1
	8	*302FV06190	2FV06190	PAD SEPARATOR	1	1
	9	*302FV06210	2FV06210	LABEL MANUAL FEED	1	1
	10	*5MMP141LD002	2A807510	PLATE SIDE GUIDE	1	1
	11	*5MMP141LD003	2A807520	PLATE STOPPER	1	1
	12	*5MMW171LD006	2A807530	SPRING STOPPER	1	1
	13	*5MMW251LD045	2A807140	SPRING LOCK	2	2
	14	*5MMW251LD047	2A807110	SPRING SEPARATOR C	1	1
⊙	15	*5MMW552LD004	2FV06120	SPRING CASSETTE	2	2
	16	*5MMX631LD003	2A807180	GUIDE SEPARATOR	1	1
	17	*5MVB864SB024	2FV06100	TRAY MULTI	1	1
	18	*5MVB887SB002	2FV06010	BASE CASSETTE	1	1
	19	*5MVG127DN071	2A807050	GEAR CASSETTE	2	2
	20	*5MVS616XN001	2A807080	PAD BOTTOM	1	1
	21	*5MVS631TX001	3BW07040	TAPE SEPARATOR OP	1	1
	22	*5MVX321SG002	2FV06090	MARKER INDICATOR	1	1
	23	*5MVX541DG002	2A807191	LEVER REAR	1	1
	24	*5MVX541DG003	2A807161	LEVER SIDE	1	1
	25	*5MVX631DN001	2FV06030	LOCK CASSETTE	2	2
	26	*5MVX642SH010	2A807100	SEPARATOR PAPER	1	1
	27	*5MVX664SH005	2FV06070	LEVER PAPER INDICATOR	1	1
	28	*5MVX762SB019	2FV06040	GUIDE MULTI L	1	1
	29	*5MVX762SB020	2FV06050	GUIDE MULTI R	1	1
	30	*5MVX864SB013	2FV06060	GUIDE TURN	1	1
	31	*5MVX876SB010	2FV06020	COVER CASSETTE	1	1

- Parts with "*" are component parts or sub-assemblies of the assembly appearing immediately above them.
- Parts with "⊙" indicates the spare parts.

- Parts with "••" are component parts or sub-assembly with "•" appearing immediately above them.

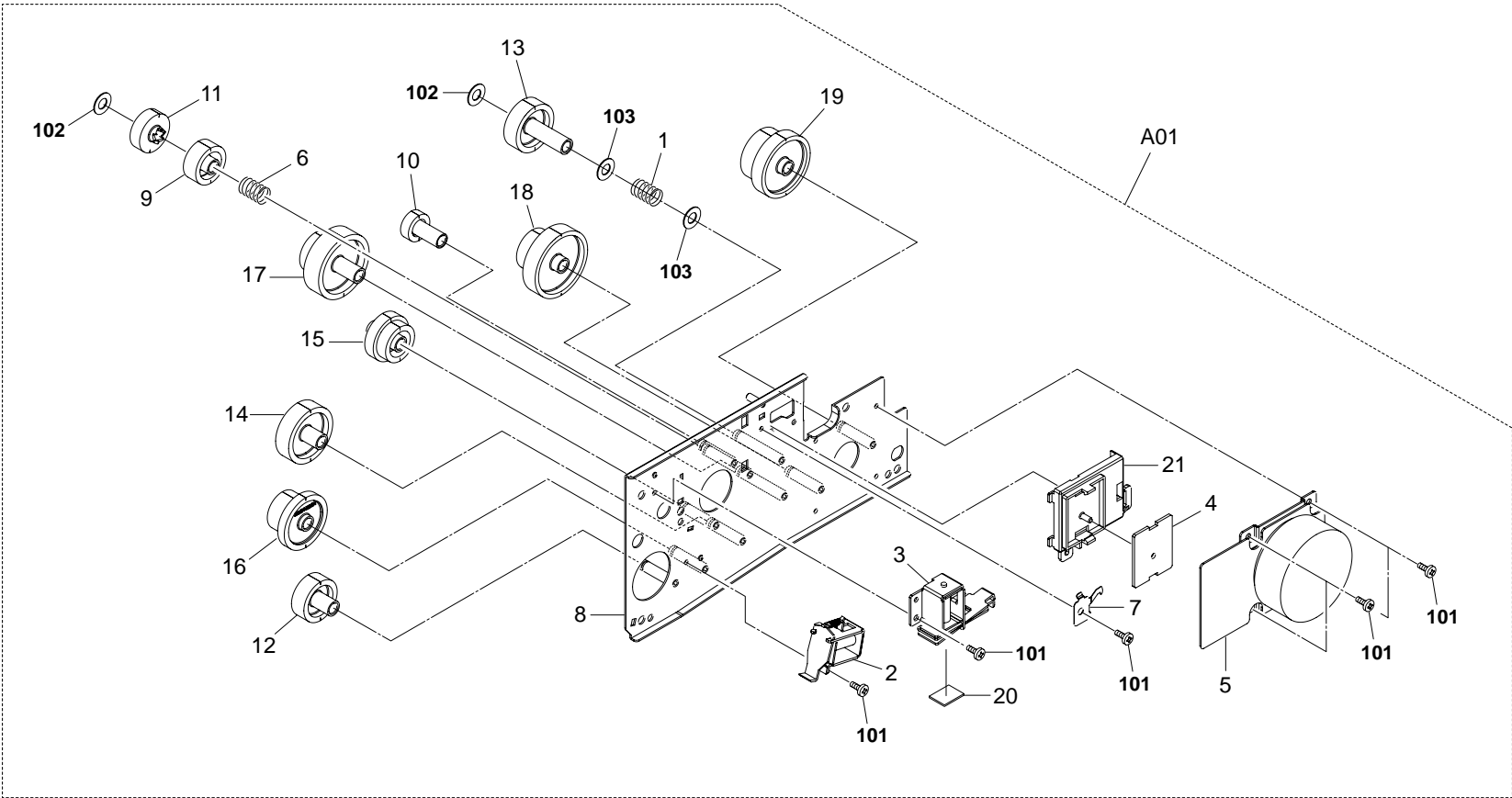

FIG. 5 Driving Unit

2G4

SP	Ref. No.	Part.No.	Alternative.	Description	Quantity	
					120	230
⊙	A01	302FV93061	2FV93061	DR-110	1	1
	1	*302FV22160	2FV22160	SPRING GEAR	1	1
⊙	2	*302GM44010	2GM44010	SOLENOID FEED	1	1
⊙	3	*302GM44020	2GM44020	SOLENOID REGIST	1	1
⊙	4	*5AAPRIFC1037AHR	2FV01080	P.W.B ASSY KP-1113	1	1
⊙	5	*5AAXMT074GEA	2FV27000	MOTOR MAIN	1	1
	6	*5MMW261LD071	2FV22010	SPRING REVERSE	1	1
	7	*5MMX321LD040	2FV22020	PLATE EARTH DRUM	1	1
	8	*5MMX874SL005	2FV22030	PLATE DRIVE	1	1
	9	*5MVG127DN132	2FV22040	GEAR FREE Z26H A	1	1
	10	*5MVG127DN133	2FV22050	GEAR Z18H	1	1
	11	*5MVG138DN089	2FV22060	GEAR FREE Z26H B	1	1
	12	*5MVG138DN090	2FV22070	GEAR Z29H	1	1
	13	*5MVG148DN108	2FV22080	GEAR Z33H	1	1
	14	*5MVG148DN109	2FV22090	GEAR Z39H	1	1
	15	*5MVG148DN110	2FV22100	GEAR Z31H-Z25H	1	1
	16	*5MVG148DN111	2FV22110	GEAR Z38H-Z26H	1	1
	17	*5MVG158DN062	2FV22120	GEAR Z45H-Z27H	1	1
	18	*5MVG168DN022	2FV22130	GEAR Z76H-Z27H	1	1
	19	*5MVG168DN023	2FV22140	GEAR Z70H-Z34H	1	1
	20	*5MVS217SN002	2A806280	PAD SOLENOID	1	1
	21	*5MVX652SB015	2FV22150	BRACKET DRIVE	1	1

SP	Ref. No.	Part.No.	Alternative.	Description	Quantity	
					120	230
	101	5MBTPB3006TW++R	B1A53060	BIND T.T SCREW(+)/ M3 X 6		
	102	5MBWL5280+NN	C2891080	POLY CUT WASHER / M5.2X8.0X0.25T		
	103	C2895950		SHIM 6.2-1.0T		

- Parts with "*" are component parts or sub-assemblies of the assembly appearing immediately above them.
- Parts with "⊙" indicates the spare parts.

- Parts with "••" are component parts or sub-assembly with "•" appearing immediately above them.

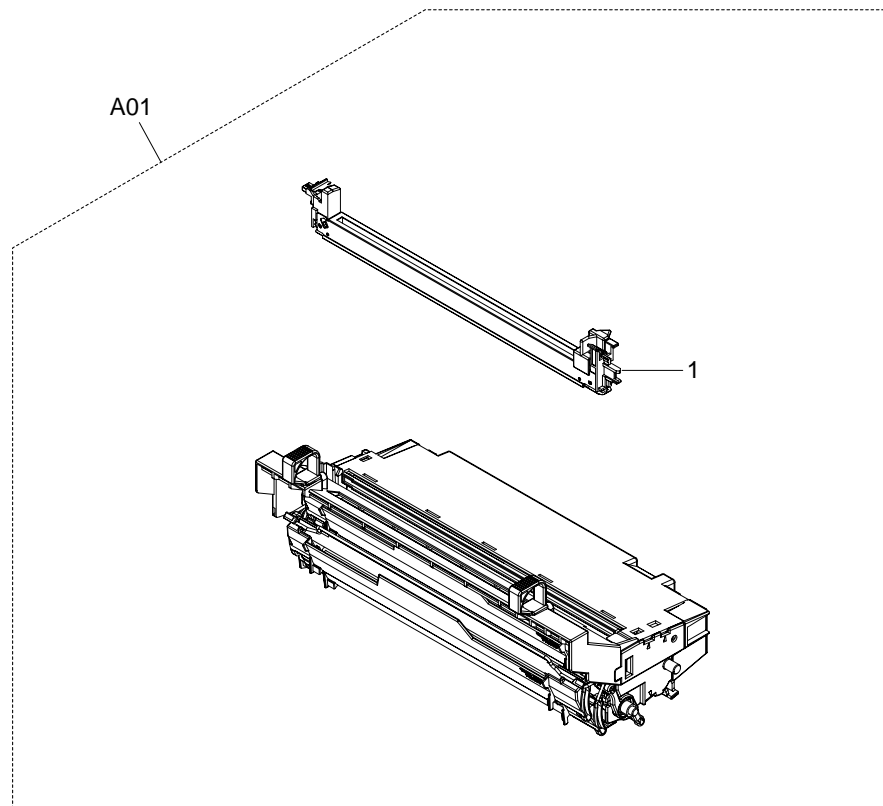

FIG. 6 Imaging Unit

2G4

SP	Ref. No.	Part.No.	Alternative.	Description	Quantity	
					120	230
⊙	A01	302FV93011	2FV93011	DK-110	1	1
⊙	1	•302FV93070	2FV93070	MC-110	1	1

- Parts with "•" are component parts or sub-assemblies of the assembly appearing immediately above them.
- Parts with "⊙" indicates the spare parts.

- Parts with "••" are component parts or sub-assembly with "•" appearing immediately above them.

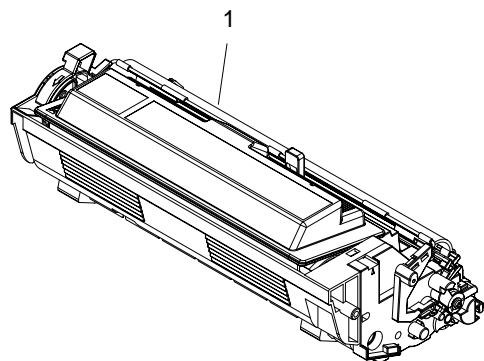

FIG. 7 Developer Unit

SP	Ref. No.	Part.No.	Alternative.	Description	Quantity	
					120	230
⊙	1	302FV93020	2FV93020	DV-110 (E)		1
⊙	1	302FV93030	2FV93030	DV-112 (U)	1	

- Parts with "•" are component parts or sub-assemblies of the assembly appearing immediately above them.
- Parts with "⊙" indicates the spare parts.

- Parts with "••" are component parts or sub-assembly with "•" appearing immediately above them.

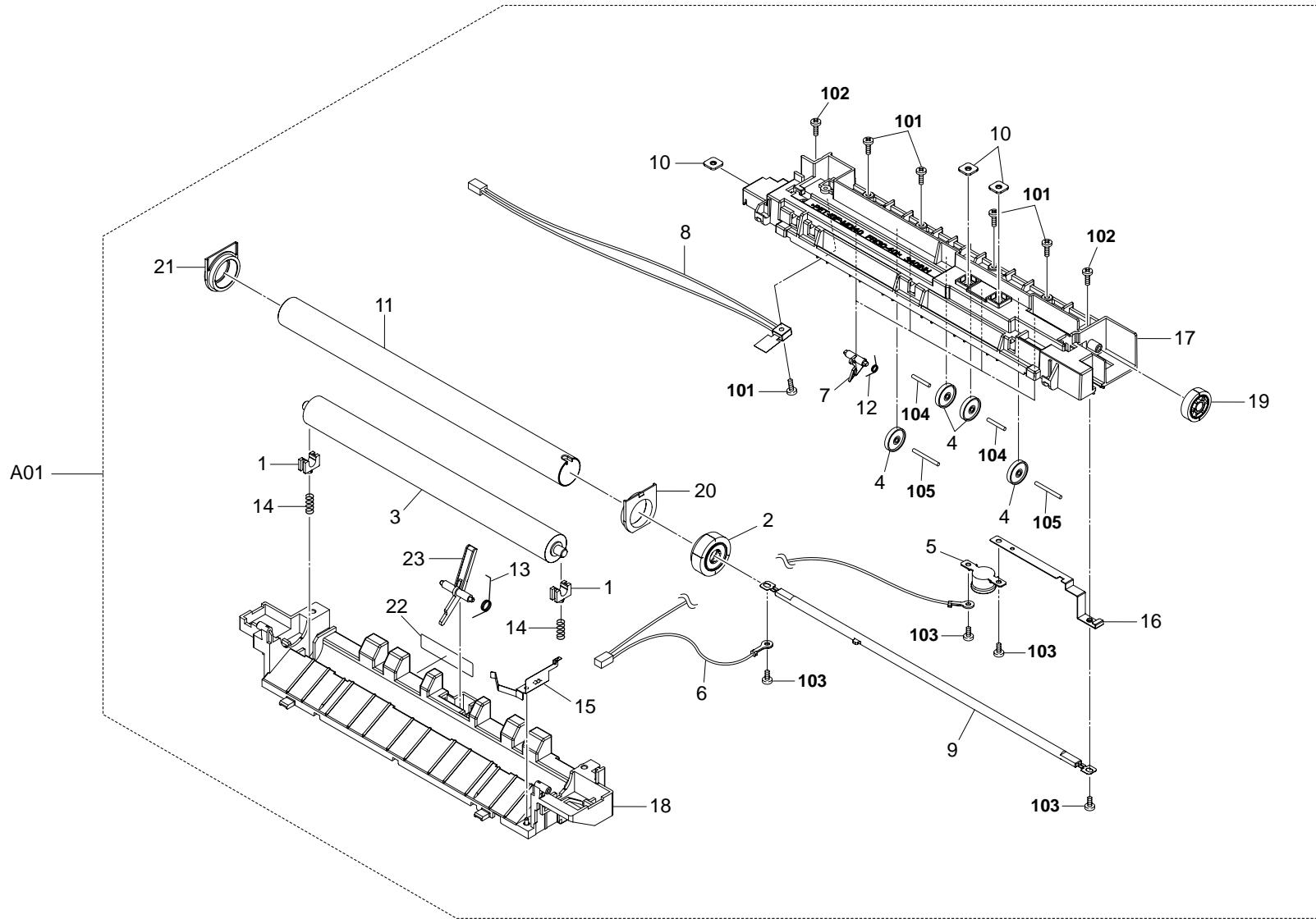

FIG. 8 Fuser Unit

2G4

SP	Ref. No.	Part.No.	Alternative.	Description	Quantity	
					120	230
⊙	A01	302FV93040	2FV93040	FK-110(E)		1
⊙	A01	302FV93050	2FV93050	FK-110(U)	1	
⊙	1	*2BY20070	5MVX221XN004	BUSH PRESS	2	2
⊙	2	*302A820161	2A820161	GEAR HEAT Z33	1	1
	3	*302DC20061	2DC20061	ROLLER PRESS	1	1
	4	*302FV20130	2FV20130	PULLEY EXIT	4	4
⊙	5	*302FV27060	2FV27060	THERMOSTAT 250V/170C	1	1
	6	*5AACNSX3GEA++R	2FV26060	CONN CORD ASSY		1
	6	*5AACNSX4GEA++R	2FV26070	CONN CORD ASSY	1	
⊙	7	*5AAVSEPR015	2A820360	SEPARATOR ASSY	4	4
⊙	8	*5AAXTM017GEA++R	2FV27040	THERMISTOR ASSY	1	1
⊙	9	*5HZPB1216320103	2FV27010	HEATER LAMP U	1	
⊙	9	*5HZPB2413120103	2FV27020	HEATER LAMP E		1
	10	*5MMS111SL002	2BY20050	NUT FUSER A	3	3
⊙	11	*5MMT876AX002	2BY20010	ROLLER HEAT	1	1
	12	*5MMW261LD072	2FV20050	SPRING SEPARATOR	4	4
	13	*5MMW261LD073	2FV20060	SPRING ACTUATOR	1	1
⊙	14	*5MMW261SD016	2FV20070	SPRING PRESS	2	2
	15	*5MMX533LD003	2FV20040	PLATE EARTH FUSER	1	1
	16	*5MMX611RD001	2FV20080	PLATE CORD	1	1
	17	*5MVB864KB009	2FV20020	FRAME FUSER UP	1	1
	18	*5MVB866KB003	2FV20010	FRAME FUSER LOW	1	1
	19	*5MVG138XN010	2FV20090	GEAR IDLE Z25	1	1
⊙	20	*5MVM188XN015	2A820120	BUSH HEAT R	1	1
⊙	21	*5MVM188XN016	2A820131	BUSH HEAT L	1	1
	22	*5MVL611WN06	2FV20100	LABEL FUSER CAUTION	1	1
⊙	23	*5MVX531CB002	2FV20030	ACTUATOR FUSER	1	1

SP	Ref. No.	Part.No.	Alternative.	Description	Quantity	
					120	230
	101	5MBTPB3012PW++R	B1A63120	BIND T.T SCREW(+)/ M3 X 12		
	102	5MBTPB4010PW++R	B1A64100	BIND T.T SCREW(+)/ M4 X 10		
	103	5MBSP43006NW++R	B4A03060	TP HEAD SCREW(+)/ M3 X 6		
	104	5MBP2012WPLD	E5120120	PARALLEL PIN / M2 X 12		
	105	7BP512016+++H01	BP010450	PARALLEL PIN / M2X16		

- Parts with "*" are component parts or sub-assemblies of the assembly appearing immediately above them.
- Parts with "⊙" indicates the spare parts.

- Parts with "••" are component parts or sub-assembly with "•" appearing immediately above them.

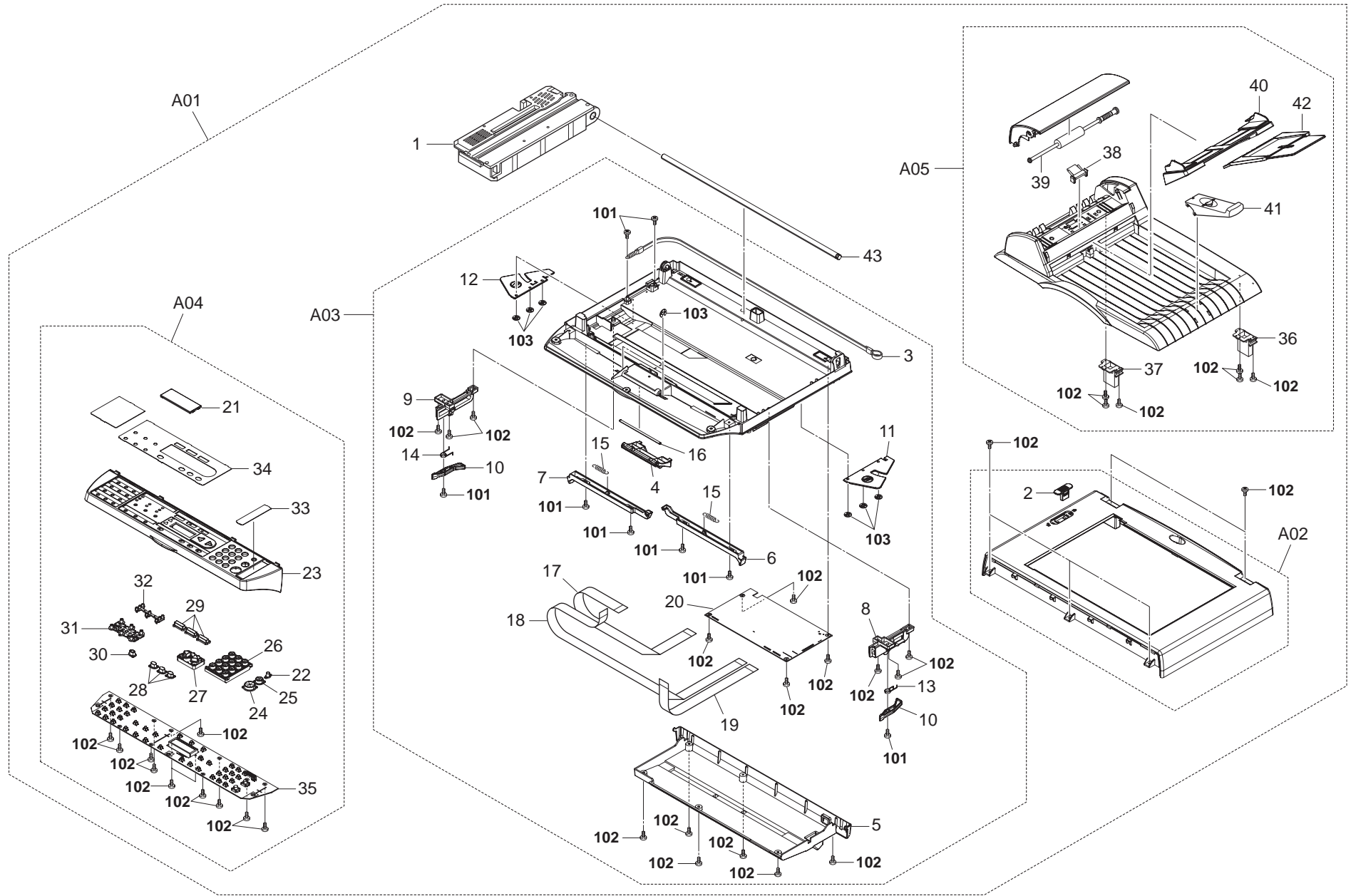

FIG. 9 MFP Unit

2G4

SP	Ref. No.	Part.No.	Alternative.	Description	Quantity	
					120	230
⊙	A01	302G445030	2G445030	UNIT MFP	1	1
⊙	1	*302G470010	2G470010	UNIT OPTICAL MODULE	1	1
⊙	A02	*302G470020	2G470020	UNIT HOUSING UPPER	1	1
⊙	2	**302G470180	2G470180	FIXER,CHASSIS	1	1
⊙	A03	*302G470030	2G470030	UNIT HOUSING BOTTOM	1	1
⊙	3	**302G470040	2G470040	UNIT BELT	1	1
⊙	4	**302G470190	2G470190	BUTTON, RELEASE	1	1
⊙	5	**302G470200	2G470200	COVER,MFP CONTROLLER	1	1
⊙	6	**302G470210	2G470210	LINK, RELEASE (R)	1	1
⊙	7	**302G470220	2G470220	LINK, RELEASE (L)	1	1
⊙	8	**302G470230	2G470230	GUIDER, ARM (R)	1	1
⊙	9	**302G470240	2G470240	GUIDER, ARM (L)	1	1
⊙	10	**302G470250	2G470250	LATCH:POM	2	2
⊙	11	**302G470260	2G470260	COVER,INSIDE (R)	1	1
⊙	12	**302G470270	2G470270	COVER,INSIDE (L)	1	1
⊙	13	**302G470280	2G470280	SPRING,TORSION (R)	1	1
⊙	14	**302G470290	2G470290	SPRING,TORSION (L)	1	1
⊙	15	**302G470300	2G470300	SPRING-2:SUS304	2	2
⊙	16	**302G470310	2G470310	PIN,RELEASE BUTTON	1	1
⊙	17	**302G470550	2G470550	FFC CABLE 18P	1	1
⊙	18	**302G470560	2G470560	FFC CABLE 20P	1	1
⊙	19	**302G470570	2G470570	FFC CABLE 22P	1	1
⊙	20	**302G470580	2G470580	P.W.BOARD ASSY MFP CONTROLLER	1	1
⊙	A04	*302G470050	2G470050	UNIT PANEL	1	1
⊙	21	**302G470360	2G470360	COVER,LCD	1	1
⊙	22	**302G470400	2G470400	BUTTON,TONER SAVE	1	1
⊙	23	**302G470410	2G470410	PANEL,UI	1	1
⊙	24	**302G470420	2G470420	BUTTON,START	1	1
⊙	25	**302G470430	2G470430	BUTTON,STOP	1	1
⊙	26	**302G470440	2G470440	BUTTON,NUMBER	1	1
⊙	27	**302G470450	2G470450	BUTTON,ARROW	1	1
⊙	28	**302G470460	2G470460	BUTTON,MENU	3	3
⊙	29	**302G470470	2G470470	BUTTON,SCAN	3	3
⊙	30	**302G470480	2G470480	BUTTON,SCAN-TO	1	1
⊙	31	**302G470490	2G470490	BUTTON,SORT	1	1
⊙	32	**302G470510	2G470510	LED	1	1
⊙	33	**302G470520	2G470520	NAMEPLATE (R)	1	1
⊙	34	**302G470530	2G470530	NAMEPLATE,CENTER	1	1
⊙	35	**302G470590	2G470590	P.W.BOARD ASSY PANEL	1	1
⊙	A05	*302G470060	2G470060	UNIT ADF MODULE	1	1
⊙	36	**302G470070	2G470070	UNIT HINGE LITE	1	1
⊙	37	**302G470080	2G470080	UNIT HINGE HEAVY	1	1
⊙	38	**302G470090	2G470090	PAD ASS'Y SCANCOPIER U-SHAPE ADF	1	1
⊙	39	**302G470100	2G470100	UNIT ADF ROLLER	1	1
⊙	40	**302G470110	2G470110	UNIT PAPER SUPPORT	1	1
⊙	41	**302G470120	2G470120	UNIT STOPPER	1	1
⊙	42	**302G470130	2G470130	UNIT PAPER TRAY	1	1
⊙	43	*302G470350	2G470350	SLIDING ROD	1	1

SP	Ref. No.	Part.No.	Alternative.	Description	Quantity	
					120	230
	101	302G470170	2G470170	SCREW: +P-H, TAP-2, 3-8		
	102	302G470320	2G470320	SCREW:TS-M3-8		
	103	302G470330	2G470330	RING CSRG B,M4		

- Parts with "*" are component parts or sub-assemblies of the assembly appearing immediately above them.
- Parts with "⊙" indicates the spare parts.

- Parts with "••" are component parts or sub-assembly with "•" appearing immediately above them.

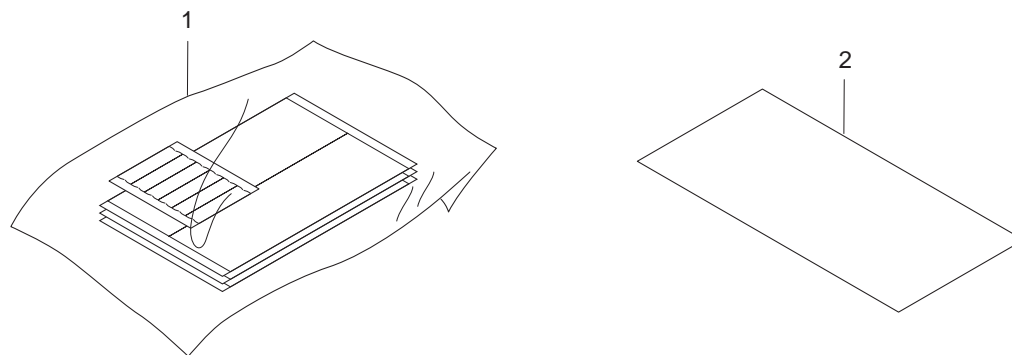

FIG. 10 Accessories & Parts Package

SP	Ref. No.	Part.No.	Alternative.	Description	Quantity	
					120	230
	1	302G405010	2G405010	SHEET PANEL SET	1	1
	2	302G405020	2G405020	SHEET PANEL SET KME		1
⊙		302FP50330	2FP50330	POLY BAG	2	2
⊙		302FV50020	2FV50020	POLY BAG	1	1

- Parts with "•" are component parts or sub-assemblies of the assembly appearing immediately above them.
- Parts with "⊙" indicates the spare parts.

- Parts with "••" are component parts or sub-assembly with "•" appearing immediately above them.

INDEX

SP	Part.No.	Alternative.	Description	Fig.No.	SP	Part.No.	Alternative.	Description	Fig.No.
⊙	2BY20070	5MVX221XN004	BUSH PRESS	8	⊙	302G404020	2G404020	COVER LID	1
	2DC07010		STOPPER PAPER	4	⊙	302G404030	2G404030	COVER SIDE L	1
	2DC07020		POSITIONING FOLIO PAPER	4	⊙	302G404040	2G404040	COVER SIDE R	1
	2DC07040		FILM SEPARATOR	4		302G404050	2G404050	TRAY SUBTRAY	1
	2DC13030		MIRROR LSU	3		302G404060	2G404060	SPRING PULLEY FD	1
	2DC27410		AC CORD ASSY	3		302G404070	2G404070	ARM LID L	1
⊙	2FM02180	5MVX221DN020	BUSH REGIST C	2		302G404080	2G404080	ARM LID R	1
	2FM02580		SPRING REGIST C	2		302G404090	2G404090	LINK LIFT L	1
	2FV06180		BOTTOM CASSETTE	4		302G404100	2G404100	LINK LIFT R	1
	302A806051	2A806051	ROLLER REGIST UP	2		302G404110	2G404110	GEAR ARM DAMPING	1
	302A807021	2A807021	GUIDE SIDE R	4		302G404130	2G404130	PIN PIVOT OD=4 L=20	1
	302A807031	2A807031	GUIDE SIDE L	4		302G404140	2G404140	PLATE LOGOTYPE	1
	302A807171	2A807171	PLATE BOTTOM	4		302G404150	2G404150	SPRING ARM	1
⊙	302A820161	2A820161	GEAR HEAT Z33	8		302G404160	2G404160	DAMPER	1
	302DC20061	2DC20061	ROLLER PRESS	8		302G404380	2G404380	LABEL LID OPERATION	1
	302F904120	2F904120	EMBLEM KYOCERA	1		302G404450	2G404450	SHEET FD	1
	302F904130	2F904130	TAPE EMBLEM	1		302G405010	2G405010	SHEET PANEL SET	10
⊙	302FP50330	2FP50330	POLY BAG	10		302G405020	2G405020	SHEET PANEL SET KME	10
⊙	302FV00030	2FV00030	TE SENSOR ASSY	2		302G439010	2G439010	LID CONTROLLER	2
⊙	302FV00040	2FV00040	FULL SENSOR ASSY	3		302G444020	2G444020	FAN MOTOR	3
	302FV02470	2FV02470	BUSH FD	2	⊙	302G445010	2G445010	UNIT LOW VOLTAGE 100	3
	302FV02480	2FV02480	SPRING ROLL	2	⊙	302G445020	2G445020	UNIT LOW VOLTAGE 200	3
⊙	302FV02490	2FV02490	SPRING TC R	2	⊙	302G445030	2G445030	UNIT MFP	9
	302FV02500	2FV02500	SHEET FAN	2		302G446010	2G446010	CONN.CORD ASSY MAIN-LSU	3
	302FV04200	2FV04200	SPRING COVER REAR R	1		302G446030	2G446030	CONN.CORD ASSY LVP-MAIN	3
	302FV06190	2FV06190	PAD SEPARATOR	4	⊙	302G470010	2G470010	UNIT OPTICAL MODULE	9
	302FV06210	2FV06210	LABEL MANUAL FEED	4	⊙	302G470020	2G470020	UNIT HOUSING UPPER	9
	302FV12070	2FV12070	SHEET ERASER	3	⊙	302G470030	2G470030	UNIT HOUSING BOTTOM	9
	302FV12080	2FV12080	LABEL LASER CAUTION	3	⊙	302G470040	2G470040	UNIT BELT	9
	302FV14500	2FV14500	LABEL GUIDE DLP	2	⊙	302G470050	2G470050	UNIT PANEL	9
	302FV20130	2FV20130	PULLEY EXIT	8	⊙	302G470060	2G470060	UNIT ADF MODULE	9
	302FV22160	2FV22160	SPRING GEAR	5		302G470070	2G470070	UNIT HINGE LITE	9
	302FV26052	2FV26052	CONN CORD ASSY	3		302G470080	2G470080	UNIT HINGE HEAVY	9
⊙	302FV27060	2FV27060	THERMOSTAT 250V170C	8	⊙	302G470090	2G470090	PAD ASS'Y SCANCOPIER U-SHAPE ADF	9
⊙	302FV45010	2FV45010	FAN MOTOR	2		302G470100	2G470100	UNIT ADF ROLLER	9
⊙	302FV45020	2FV45020	AC CORD ASSY	3		302G470110	2G470110	UNIT PAPER SUPPORT	9
⊙	302FV50020	2FV50020	POLY BAG	10		302G470120	2G470120	UNIT STOPPER	9
⊙	302FV93011	2FV93011	DK-110	6		302G470130	2G470130	UNIT PAPER TRAY	9
⊙	302FV93020	2FV93020	DV-110 (E)	7		302G470180	2G470180	FIXER,CHASSIS	9
⊙	302FV93030	2FV93030	DV-112 (U)	7		302G470190	2G470190	BUTTON, RELEASE	9
⊙	302FV93040	2FV93040	FK-110(E)	8		302G470200	2G470200	COVER,MFP CONTROLLER	9
⊙	302FV93050	2FV93050	FK-110(U)	8		302G470210	2G470210	LINK, RELEASE (R)	9
⊙	302FV93061	2FV93061	DR-110	5		302G470220	2G470220	LINK, RELEASE (L)	9
⊙	302FV93070	2FV93070	MC-110	6		302G470230	2G470230	GUIDER, ARM (R)	9
⊙	302FV93080	2FV93080	CT-110	4		302G470240	2G470240	GUIDER, ARM (L)	9
⊙	302FV93092	2FV93092	LK-110	3		302G470250	2G470250	LATCH:POM	9
	302G402010	2G402010	BRACKET FAN	3		302G470260	2G470260	COVER,INSIDE (R)	9
	302G402030	2G402030	LABEL JAM OPERATION	2		302G470270	2G470270	COVER,INSIDE (L)	9
	302G402040	2G402040	LABE CONT OPERATION	3		302G470280	2G470280	SPRING,TORSION (R)	9
⊙	302G404010	2G404010	COVER TOP PRINTER	1		302G470290	2G470290	SPRING,TORSION (L)	9

• Parts with "⊙" indicates the spare parts.

SP	Part.No.	Alternative.	Description	Fig.No.	SP	Part.No.	Alternative.	Description	Fig.No.
	302G470300	2G470300	SPRING-2:SUS304	9		5MMU862SL001	2FV02250	PLATE EARTH GUIDE	2
	302G470310	2G470310	PIN,RELEASE BUTTON	9		5MMW126SD001	2FV04130	SPRING COVER REAR	1
	302G470350	2G470350	SLIDING ROD	9		5MMW165SD001	2FV02400	SPRING STOPPER L	3
⊙	302G470360	2G470360	COVER LCD			5MMW165SD002	2FV02410	SPRING STOPPER R	3
⊙	302G470400	2G470400	BUTTON,TONER SAVE	9		5MMW171LD006	2A807530	SPRING STOPPER	4
⊙	302G470410	2G470410	PANEL,UI	9		5MMW251LD045	2A807140	SPRING LOCK	4
⊙	302G470420	2G470420	BUTTON,START	9		5MMW251LD047	2A807110	SPRING SEPARATOR C	4
⊙	302G470430	2G470430	BUTTON,STOP	9	⊙	5MMW261LD023	2A806410	SPRING REGIST R	2
⊙	302G470440	2G470440	BUTTON,NUMBER	9		5MMW261LD036	2A814570	SPRING TE SENSOR	2
⊙	302G470450	2G470450	BUTTON,ARROW	9		5MMW261LD066	2FV02260	SPRING ACTUATOR	2
⊙	302G470460	2G470460	BUTTON,MENU	9		5MMW261LD067	2FV02270	SPRING LEVER LOCK L	2
⊙	302G470470	2G470470	BUTTON,SCAN	9		5MMW261LD068	2FV02280	SPRING LEVER LOCK R	2
⊙	302G470480	2G470480	BUTTON,SCAN-TO	9		5MMW261LD069	2FV02290	SPRING EXIT	2
⊙	302G470490	2G470490	BUTTON,SORT	9		5MMW261LD070	2FV12010	SPRING FULL SENSOR	3
	302G470510	2G470510	LED	9		5MMW261LD071	2FV22010	SPRING REVERSE	5
⊙	302G470520	2G470520	NAMEPLATE (R)	9		5MMW261LD072	2FV20050	SPRING SEPARATOR	8
⊙	302G470530	2G470530	NAMEPLATE,CENTER	9		5MMW261LD073	2FV20060	SPRING ACTUATOR	8
	302G470550	2G470550	FFC CABLE 18P	9	⊙	5MMW261SD016	2FV20070	SPRING PRESS	8
	302G470560	2G470560	FFC CABLE 20P	9		5MMW361LD028	2FV02310	SPRING PIN BIAS	2
	302G470570	2G470570	FFC CABLE 22P	9		5MMW371LD006	2FV02320	SPRING FREE	2
⊙	302G470580	2G470580	P.W.BOARD ASSY MFP CONTROLLER	9		5MMW451LD001	2B700570	SPRING INTERLOCK	2
⊙	302G470590	2G470590	P.W.BOARD ASSY PANEL	9	⊙	5MMW552LD004	2FV06120	SPRING CASSETTE	4
⊙	302G480010	2G480010	P.W.B ASSY ENGINE(SP)	3		5MMX221LD034	2FV12030	SPRING MIRROR	3
⊙	302G622010	2G622010	SPRING TC L	2		5MMX321LD040	2FV22020	PLATE EARTH DRUM	5
⊙	302GM44010	2GM44010	SOLENOID FEED	5		5MMX331LD005	2FV02330	PLATE CONTACT TC	2
⊙	302GM44020	2GM44020	SOLENOID REGIST	5		5MMX522LD013	2FV02340	PLATE EARTH FEED	2
	5AACCNX3GGEA++R	2FV26060	CONN CORD ASSY	8		5MMX533LD003	2FV20040	PLATE EARTH FUSER	8
	5AACCNX4GGEA++R	2FV26070	CONN CORD ASSY	8		5MMX541LD002	2FV02350	PLATE EARTH A	3
⊙	5AAPRELC1008AHR	2FV01100	P.W.B.ASSY KP-5157	3		5MMX611RD001	2FV20080	PLATE CORD	8
⊙	5AAPRIFC1037AHR	2FV01080	P.W.B ASSY KP-1113	5		5MMX631LD003	2A807180	GUIDE SEPARATOR	4
⊙	5AAVCLTCH028	2BY02020	CLUTCH FEED	2		5MMX643LD006	2FV02360	PLATE EARTH B	2
⊙	5AAVCLTCH032	2FV02180	CLUTCH REGIST	2		5MMX763LD007	2FV02370	PLATE CONTACT MC	2
⊙	5AAVROLL+044	2A806010	ROLLER FEED ASSY	2		5MMX874SL005	2FV22030	PLATE DRIVE	5
⊙	5AAVSEPR015	2A820360	SEPARATOR ASSY	8		5MMX884SL002	2FV02380	PLATE BOTTOM FRAME	3
⊙	5AAXMT074GEA	2FV27000	MOTOR MAIN	5		5MVB763CB001	2FV02010	COVER MC	2
⊙	5AAXTM017GEA++R	2FV27040	THERMISTOR ASSY	8		5MVB864KB009	2FV20020	FRAME FUSER UP	8
⊙	5HZPB1216320103	2FV27010	HEATER LAMP U	8		5MVB864SB024	2FV06100	TRAY MULTI	4
⊙	5HZPB2413120103	2FV27020	HEATER LAMP E	8		5MVB866KB003	2FV20010	FRAME FUSER LOW	8
	5MMP141LD002	2A807510	PLATE SIDE GUIDE	4	⊙	5MVB874SB011	2FV04060	COVER REAR	1
	5MMP141LD003	2A807520	PLATE STOPPER	4		5MVB887SB002	2FV06010	BASE CASSETTE	4
	5MMS111SL002	2BY20050	NUT FUSER A	8	⊙	5MVG126DB025	2A806240	GEAR REGIST Z13	2
	5MMS821LD014	2A816080	BRUSH DISCHARGER	2	⊙	5MVG127DB047	2A806230	GEAR REGIST Z20	2
	5MMS875SL007	2FV12020	COVER SCANNER	3	⊙	5MVG127DN071	2A807050	GEAR CASSETTE	4
	5MMT365SN003	2A815020	PIN CONTACT BIAS	2	⊙	5MVG127DN130	2FV02020	GEAR FD Z19S	2
⊙	5MMT463SN002	2FV02200	PIN DRIVE	2	⊙	5MVG127DN131	2FV02030	GEAR TC Z17	2
	5MMT766SN011	2FV02210	SHAFT FEED	2		5MVG127DN132	2FV22040	GEAR FREE Z26H A	5
	5MMT875SN016	2FV02220	ROLLER FD	2	⊙	5MVG127DN133	2FV22050	GEAR Z18H	5
⊙	5MMT876AX002	2BY20010	ROLLER HEAT	8	⊙	5MVG138DN088	2FV02040	GEAR FREE Z28S	2
⊙	5MMT876SN104	2FV02230	ROLLER TRANSFER	2		5MVG138DN089	2FV22060	GEAR FREE Z26H B	5
⊙	5MMT876SN105	2FV02240	ROLLER REGIST LOW	2		5MVG138DN090	2FV22070	GEAR Z29H	5

• Parts with "⊙" indicates the spare parts.

SP	Part.No.	Alternative.	Description	Fig.No.	SP	Part.No.	Alternative.	Description	Fig.No.
	5MVG138XN010	2FV20090	GEAR IDLE Z25	8		5MVX763SB011	2FV02150	ROD INTERLOCK	2
⊙	5MVG148DN107	2FV02050	GEAR Z34S	2		5MVX821SB014	2FV12050	SHUTTER LSU	3
	5MVG148DN108	2FV22080	GEAR Z33H	5		5MVX864SB013	2FV06060	GUIDE TURN	4
	5MVG148DN109	2FV22090	GEAR Z39H	5		5MVX865SB008	2FV02160	GUIDE FEED	2
	5MVG148DN110	2FV22100	GEAR Z31H-Z25H	5		5MVX876SB010	2FV06020	COVER CASSETTE	4
	5MVG148DN111	2FV22110	GEAR Z38H-Z26H	5		5MVX876XB002	2FV12060	FRAME MID	3
⊙	5MVG158DN059	2FV02060	GEAR FREE Z46H	2		5MVX888CB001	2FV02170	FRAME BASE	2
⊙	5MVG158DN060	2FV02070	GEAR FD Z42S	2		7YZM610003++H01	YZ010250	ACCESS SADDLE	2
⊙	5MVG158DN061	2FV02080	GEAR FD Z45S	2		M70CA010		FERRITE CORE,SFT-72SN(TAKEUCHI)	2
	5MVG158DN062	2FV22120	GEAR Z45H-Z27H	5					
	5MVG168DN022	2FV22130	GEAR Z76H-Z27H	5					
	5MVG168DN023	2FV22140	GEAR Z70H-Z34H	5					
	5MVM176DN016	2BR20170	BUSH A	2					
⊙	5MVM188XN015	2A820120	BUSH HEAT R	8					
⊙	5MVM188XN016	2A820131	BUSH HEAT L	8					
⊙	5MVM363DB001	2FV04150	PULLEY FD	1					
⊙	5MVM776DB001	2FV02090	PULLEY FEED	2					
	5MVS217SN002	2A806280	PAD SOLENOID	5					
	5MVS616XN001	2A807080	PAD BOTTOM	4					
	5MVS625XF001	2FV04140	DISCHARGER FD	1					
	5MVS631TX001	3BW07040	TAPE SEPARATOR OP	4					
⊙	5MVS721KF007	2FV02390	SHEET REGIST	2					
	5MVS777CB001	2FV02000	COVER PWB	3					
	5MVS812KF006	2A816090	SHEET DISCHARGER	2					
	5MVS812XF003	2A816120	TAPE BRUSH	2					
	5MVL611WN06	2FV20100	LABEL FUSER CAUTION	8					
	5MVX111DN003	2A806250	RING STOPPER	2					
⊙	5MVX221DB019	2A806420	BUSH REGIST LEFT	2					
⊙	5MVX221DB023	2A816020	BUSH TC L	2					
⊙	5MVX221DW006	2A806430	BUSH REGIST RIGHT	2					
⊙	5MVX221DW008	2A816030	BUSH TC R	2					
	5MVX221RB014	2BS03110	FOOT	3					
	5MVX321SG002	2FV06090	MARKER INDICATOR	4					
	5MVX431DN005	2FV02100	LEVER LOCK DLP	2					
	5MVX431SB012	2FV02450	RAIL FRAME	3					
	5MVX432SB014	2FV02460	BKT ACTUATOR EXIT	2					
⊙	5MVX441SB006	2FV02110	ACTUATOR REGIST	2					
⊙	5MVX442SB011	2FV02120	ACTUATOR EXIT	2					
⊙	5MVX531CB002	2FV20030	ACTUATOR FUSER	8					
	5MVX541DG002	2A807191	LEVER REAR	4					
	5MVX541DG003	2A807161	LEVER SIDE	4					
	5MVX552DB001	2FV02130	ACTUATOR EMPTY	2					
	5MVX631DN001	2FV06030	LOCK CASSETTE	4					
	5MVX631SB006	2FV02420	LEVER STOPPER L	3					
	5MVX631SB007	2FV02430	LEVER STOPPER R	3					
	5MVX642SH010	2A807100	SEPARATOR PAPER	4					
	5MVX652SB015	2FV22150	BRACKET DRIVE	5					
	5MVX664SH005	2FV06070	LEVER PAPER INDICATOR	4					
	5MVX762SB019	2FV06040	GUIDE MULTI L	4					
	5MVX762SB020	2FV06050	GUIDE MULTI R	4					

• Parts with "⊙" indicates the spare parts.