

## 5 Parts Lists

### Introduction

Introduction .....	5-3
Subsystem Information .....	5-4
Symbology .....	5-5

FOREIGN INTERFACE = 98K65090

### MAIN DRIVES

PL 1.1 DRIVE ASSEMBLY .....	5-7
PL 1.2 DRIVE COMPONENTS .....	5-8

### PAPER FEED AND REGISTRATION

PL 2.1 TRAY 1 (500 SHEET) .....	5-9
PL 2.2 TRAY 2 (250 SHEET) .....	5-10
PL 2.3 DOOR TRANSPORT MODULE .....	5-11
PL 2.4 DOOR TRANSPORT COMPONENTS (PART 1 OF 2) AND BY-PASS TRAY ...	5-12
PL 2.5 DOOR TRANSPORT COMPONENTS (PART 2 OF 2) .....	5-13

### IMAGER

PL 3.1 IMAGER COMPONENTS .....	5-14
--------------------------------	------

### XEROGRAPHICS

PL 4.1 COPY CARTRIDGE MODULE .....	5-15
------------------------------------	------

### FUSER

PL 5.1 FUSER MODULE .....	5-16
---------------------------	------

### ELECTRICAL

PL 6.1 POWER/CONTROL MODULE (PCM) COMPONENTS .....	5-17
--	------

### FRAMES AND COVERS

PL 7.1 COVERS .....	5-18
---------------------	------

### SET DOCUMENT FEEDER (SDF)

PL 8.1 SDF MODULE .....	5-19
PL 8.2 SDF COMPONENTS .....	5-20
Part Number Index .....	5-21

## Introduction

### Overview

The Parts List section identifies all part numbers and the corresponding location of all spared subsystem components.

### Organization

#### Parts Lists

Each item number in the part number listing corresponds to an item number in the related illustration. All the parts in a given subsystem of the machine will be located in the same illustration or in a series of associated illustrations.

#### Electrical Connectors and Fasteners

This section contains the illustrations and descriptions of the plugs, jacks, and fasteners used in the machine. A part number listing of the connectors is included.

#### Common Hardware

The common hardware is listed in alphabetical order by the letter or letters used to identify each item in the part number listing and in the illustrations. Dimensions are in millimeters unless otherwise identified.

#### Part Number Index

This index lists all the spared parts in the machine in numerical order. Each number is followed by a reference to the parts list on which the part may be found.

## Other Information

### Abbreviations

Abbreviations are used in the parts lists and the exploded view illustrations to provide information in a limited amount of space. The following abbreviations are used in this manual:

Table 1

Abbreviation	Meaning
A	AMP
AC	Alternating Current
AO	Americas Operations
DH	Document Handler
HZ	Hertz
M	Millimeter
P/O	Part of
PWB	Printed Wiring Board
RDH	Recirculating Document Handler
REF	Reference
R/E	Reduction Enlargement
USCO	United States Customer Operations
V	Volt
W/	With
W/O	Without
XCL	Xerox Canada Limited
XL	Xerox Limited

### Symbology

Symbology used in the Parts List section is identified in the Symbology section.

### Service Procedure Referencing

If a part or assembly has an associated repair or adjustment procedure, the procedure number will be listed at the end of the part description in the parts lists e.g. (REP 5.1, ADJ 5.3)

## Subsystem Information

### Use of the Term "Assembly"

The term "assembly" will be used for items in the part number listing that include other itemized parts in the part number listing. When the word "assembly" is found in the part number listing, there will be a corresponding item number on the illustrations followed by a bracket and a listing of the contents of the assembly.

### Brackets

A bracket is used when an assembly or kit is spared, but is not shown in the illustration. The item number of the assembly or kit precedes the bracket; the item numbers of the piece parts follow the bracket.

### Tag

The notation "W/Tag" in the parts description indicates that the part configuration has been updated. Check the change Tag index in the General Information section of the Service Data for the name and purpose of the modification.

A Tag identifier is a one letter code that indicates the subsystem area of a modification.

A-010 - ADH Tag 010  
C-010 - OCT Tag 010  
F-010 - Finisher Tag 010  
P-010 - Processor Tag 010  
R-010 - RDH Tag 010  
S-010 - Sorter Tag 010

In some cases, a part or assembly may be spared in two versions: with the Tag and without the Tag. In those cases, use whichever part is appropriate for the configuration of the machine on which the part is to be installed. If the machine does not have a particular Tag and the only replacement part available is listed as "W/Tag," install the Tag kit or all of the piece parts. The Change Tag Index tells you which kit or piece parts you need.

Whenever you install a Tag kit or all the piece parts that make up a Tag, mark the appropriate number on the Tag matrix.

## Symbology

A Tag number within a circle pointing to an item number shows that the part has been changed by the tag number within the circle (Figure 1). Information on the modification is in the Change Tag Index.

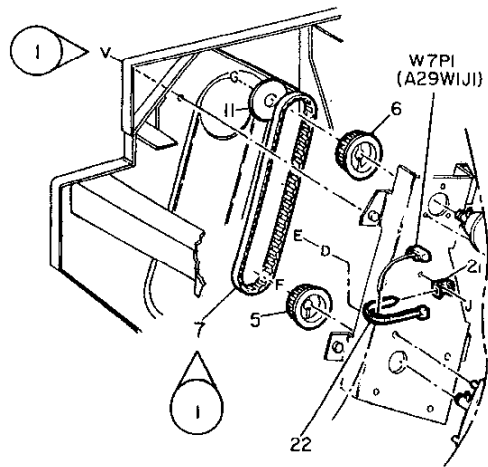

0	Z004	A
850	PL	M I

Figure 1 With Tag Symbol

A Tag number within a circle having a shaded bar and pointing to an item number shows that the configuration of the part shown is the configuration before the part was changed by the Tag number within the circle (Figure 2).

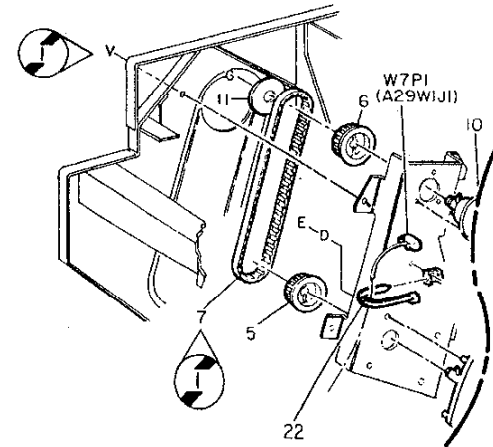

0	Z005	A
850	PL	M I

Figure 2 Without Tag Symbol

A tag number within a circle with no apex shows that the entire drawing has been changed by the tag number within the circle (Figure 3). Information on the modification is in the Change Tag Index.

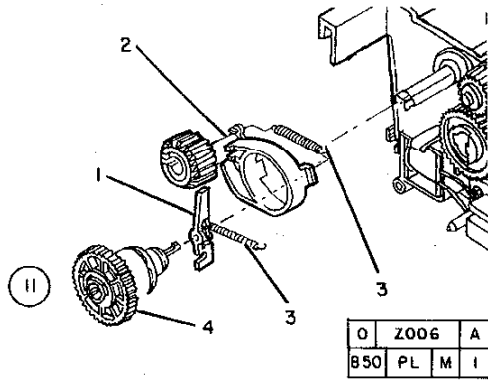

Figure 3 Entire Drawing With Tag Symbol

A tag number within a circle with no apex and having a shaded bar shows that the entire drawing was the configuration before being changed by the tag number within the circle (Figure 4).

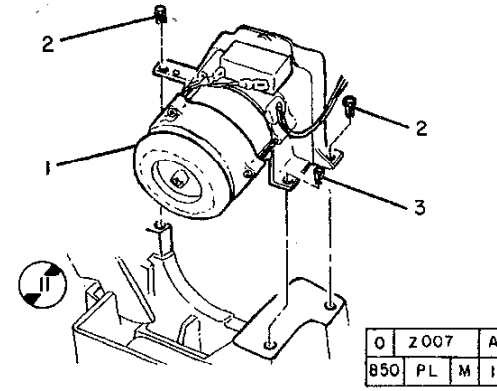
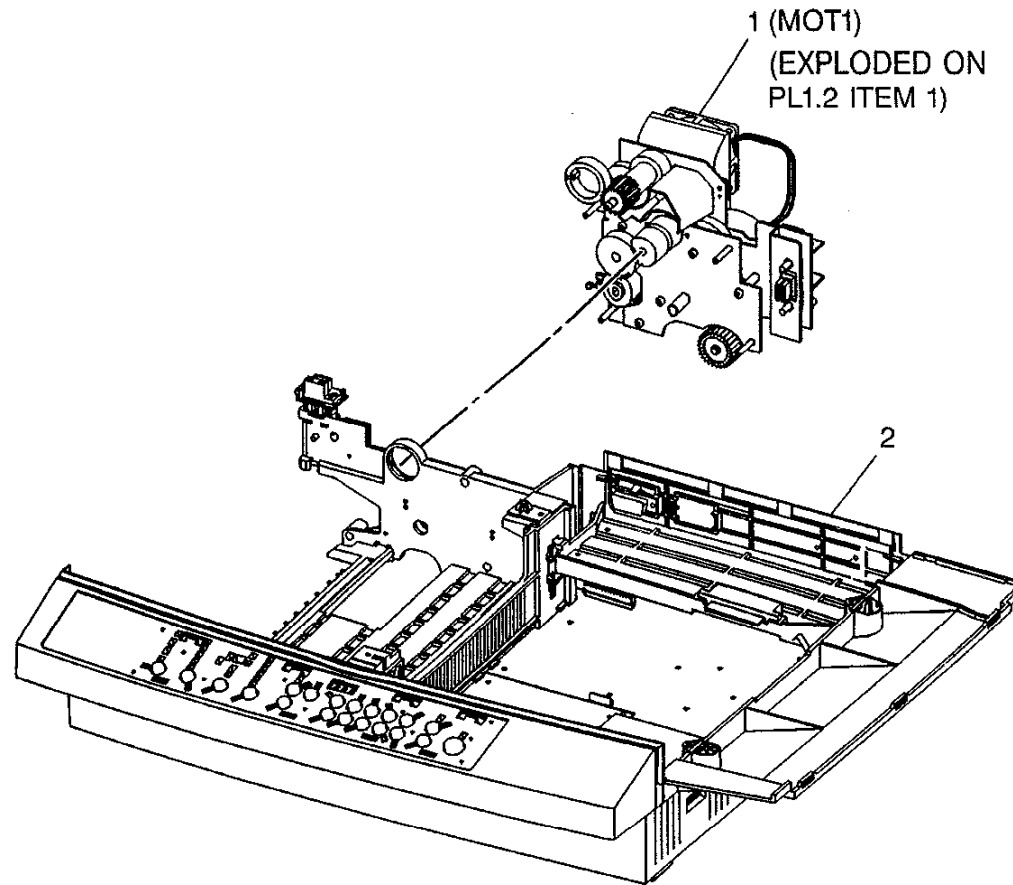

Figure 4 Entire Drawing Without Tag Symbol

## PL 1.1 DRIVE ASSEMBLY

Item	Part	Description
1	7K10024	DRIVE ASSEMBLY (MOT1) (REP 4.1)
2	-	ELECTRONIC CONTROL SYSTEM HOUSING (NOT SPARED)



0000006A-AFF

## PL 1.2 DRIVE COMPONENTS

Item	Part	Description
1	-	PART OF DRIVE ASSEMBLY (REF: PL 1.1 item 1)
2	600K62990	COOLING FAN KIT
3	<del>127K22800</del>	COOLING FAN (MOT2) (P/O PL 1.2 item 2) (REP 4.2)
4	-	DRIVE FRAME (P/O PL 1.2 item 1)

1 { 4

2 { 3

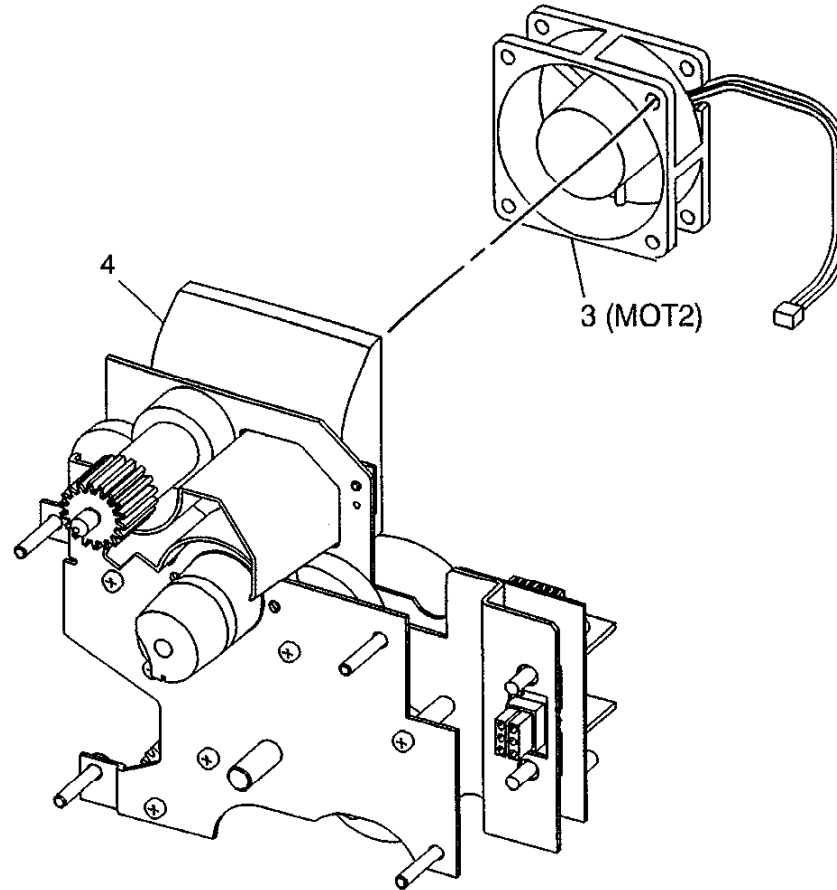

000007A-AFF

## PL 2.1 TRAY 1 (500 SHEET)

Item	Part	Description
1	121E13870	TRAY 1 FEED SOLENOID (SOL1) (REP 4.3)
2	7K10120	TRAY 1 / TRAY 2 DRIVE GEARS (REP 4.5)
3	600K62850	TRAY 1 SECTOR GEAR KIT
4	-	SPRING (P/O PL 2.1 item 3)
5	<del>7E49450</del>	TRAY 1 SECTOR GEAR (P/O PL 2.1 item 3) (REP 4.4)
6	600K62900	FEED ROLL KIT
7	-	TRAY 1 FEED ROLL (P/O PL 2.1 item 6) (REP 8.13)
8	6E66580	TRAY 1 / TRAY 2 FEED SHAFT (REP 8.15)
9	600K62890	TRAY 1 DRAWER KIT
10	-	TRAY 1 DRAWER (P/O PL 2.1 item 9) (REP 8.11)
11	-	TRAY 1 HOUSING (NOT SPARED)

3 { 4, 5  
6 { 7  
9 { 10

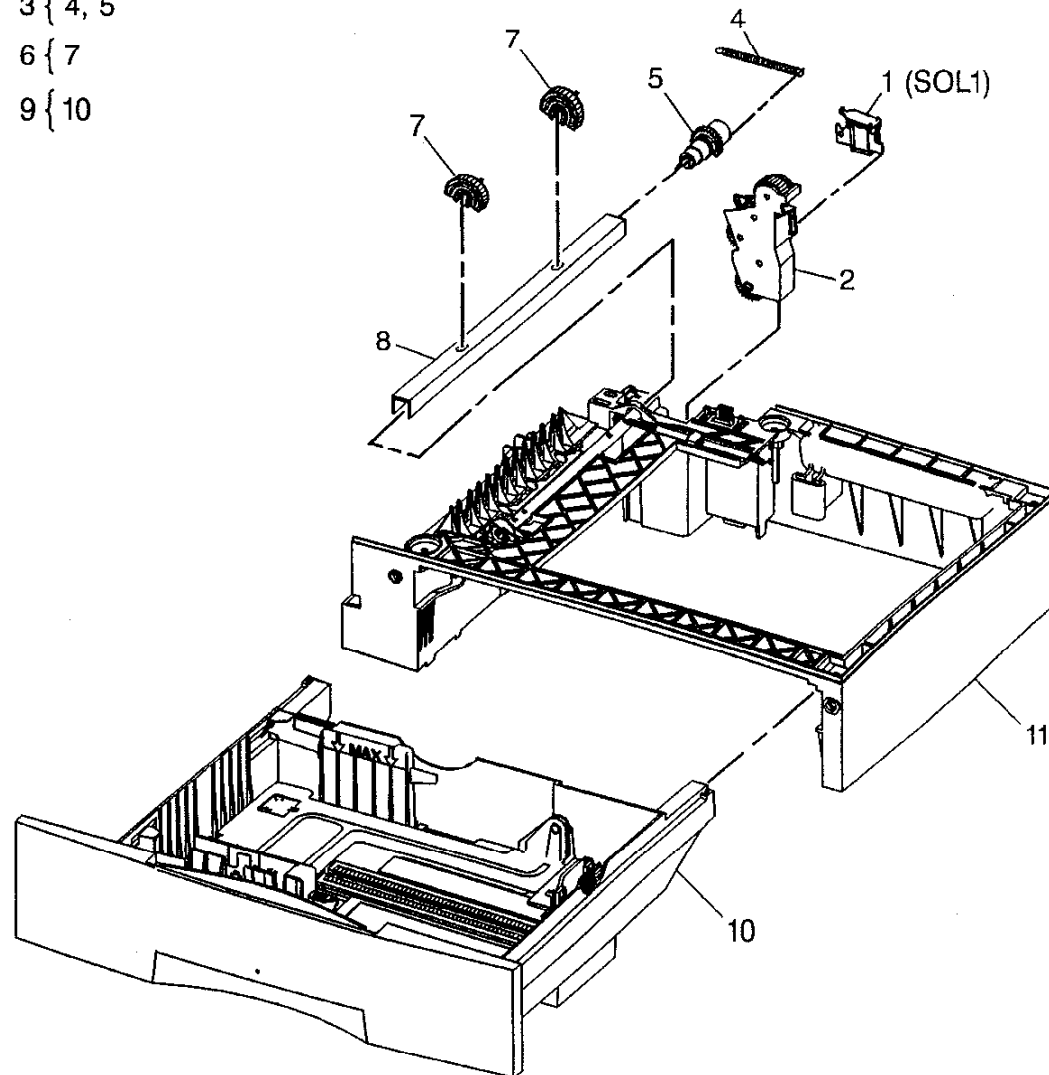

000005B-AFF



## PL 2.2 TRAY 2 (250 SHEET)

Item	Part	Description
1	600K63051	TRAY 2 REAR COVER KIT
2	-	TRAY 2 REAR COVER (P/O PL 2.2 item 1)
3	121E13870	TRAY 2 FEED SOLENOID (SOL2) (REP 4.6)
4	7K10140	TRAY 2 DRIVE GEARS (REP 4.8)
5	7K10130	INTERFACE GEAR
6	600K62850	TRAY 2 SECTOR GEAR KIT
7	<del>7E49450</del>	TRAY 2 SECTOR GEAR (P/O PL 2.2 item 6) (REP 4.7)
8	-	SPRING (P/O PL 2.2 item 6)
9	600K62900	FEED ROLL KIT
10	-	TRAY 2 FEED ROLL (P/O PL 2.2 item 9) (REP 8.14)
11	6E66580	TRAY 1 / TRAY 2 FEED SHAFT (REP 8.19)
12	600K64100	TAKEAWAY ROLL KIT
13	-	TRAY 2 TAKEAWAY ROLL (P/O PL 2.2 item 11)(REP 8.18)
14	600K63040	TRAY 2 DRAWER MODULE KIT (REP 8.10)
15	-	TRAY 2 ACCESS DRAWER (P/O PL 2.2 item 13)(REP 8.17)
16	600K62910	TRAY 2 DRAWER ASSEMBLY KIT
17	-	TRAY 2 DRAWER ASSEMBLY (P/O PL 2.2 item 16)(REP 8.16)
18	-	TRAY 2 HOUSING (NOT SPARED)

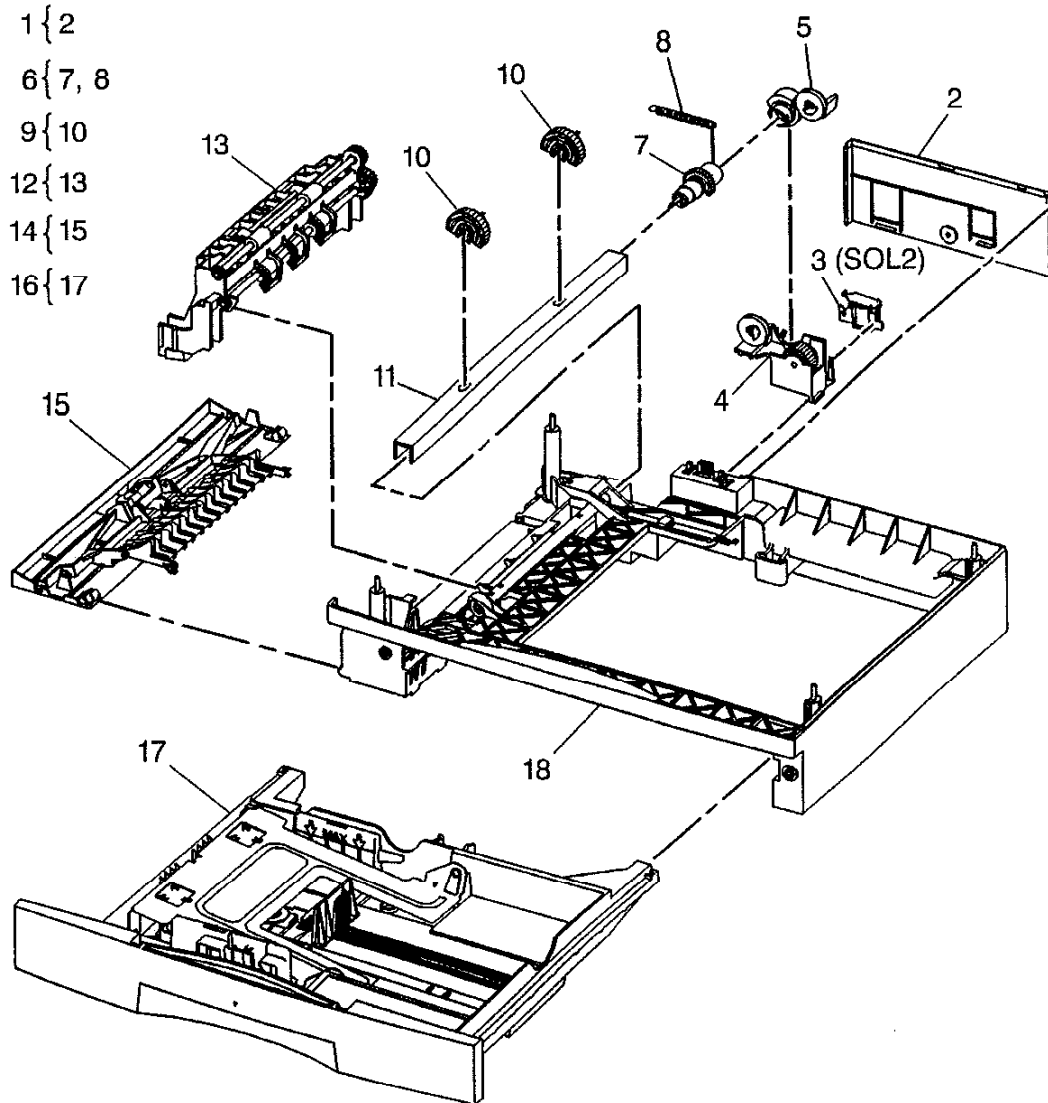

000004B-AFF

**PL 2.3 DOOR TRANSPORT MODULE**

Item	Part	Description
1	600K62943	DOOR TRANSPORT MODULE KIT
2	-	DOOR TRANSPORT MODULE (P/O PL 2.3 item 1) (REP 8.1)
3	-	COPY INPUT MODULE (NOT SPARED)

1 { 2

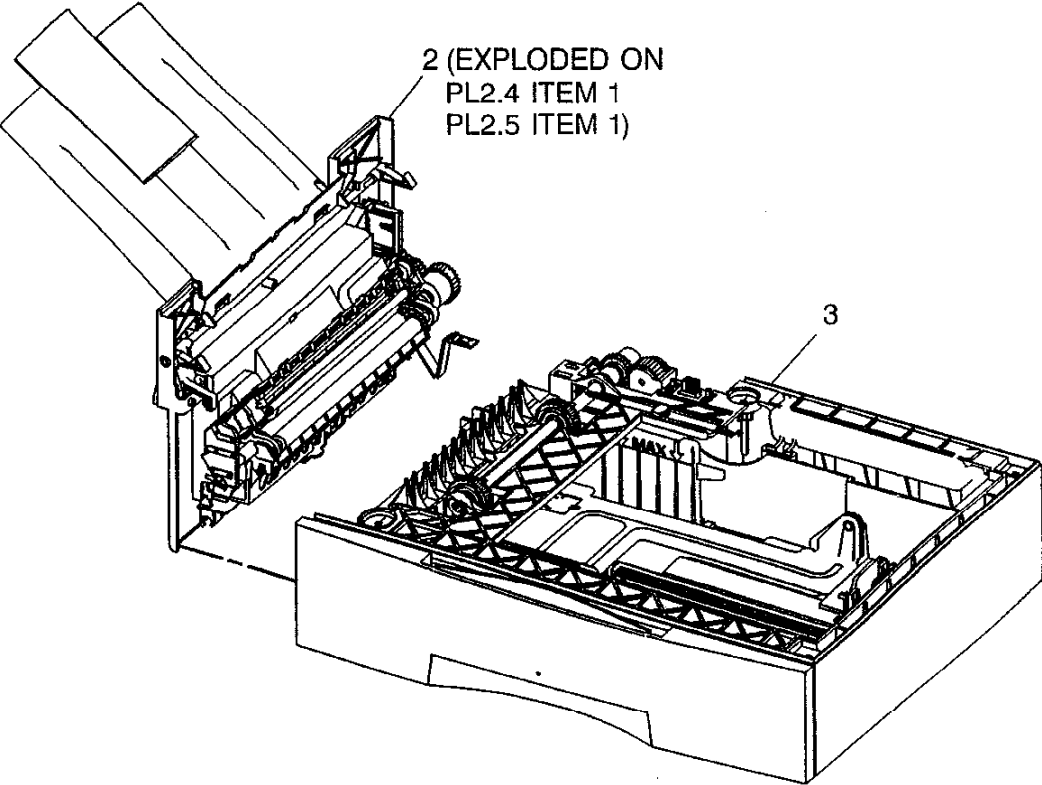

0000001A-AFF

**PL 2.4 DOOR TRANSPORT  
COMPONENTS (PART 1 OF 2) AND  
BY-PASS TRAY**

Item	Part	Description
1	-	PART OF DOOR TRANSPORT MODULE KIT (REF: PL 2.3 item 2)
2	-	DOOR FRAME (P/O PL 2.4 item 1)
3	600K62983	OUTPUT TRAY KIT
4	-	OUTPUT TRAY (P/O PL 2.4 item 3) (REP 8.9)
5	600K62970	BY-PASS TRAY KIT
6	-	BY-PASS TRAY (P/O PL 2.4 item 5) (REP 8.7)
7	-	NUDGER BAR (P/O PL 2.4 item 1)
* 8	<del>600K71890</del>	COPY CURL REPAIR KIT <i>NOT SPACED</i>
9	-	SPACER STRIP (P/O PL 2.4 item 8)
10	-	BY-PASS FEED ROLL (P/O PL 2.4 item 1) (REP 8.12)
11	-	BY-PASS RETARD PAD (P/O PL 2.4 item 1) (REP 8.21)

\* 600K72090 CURL KIT

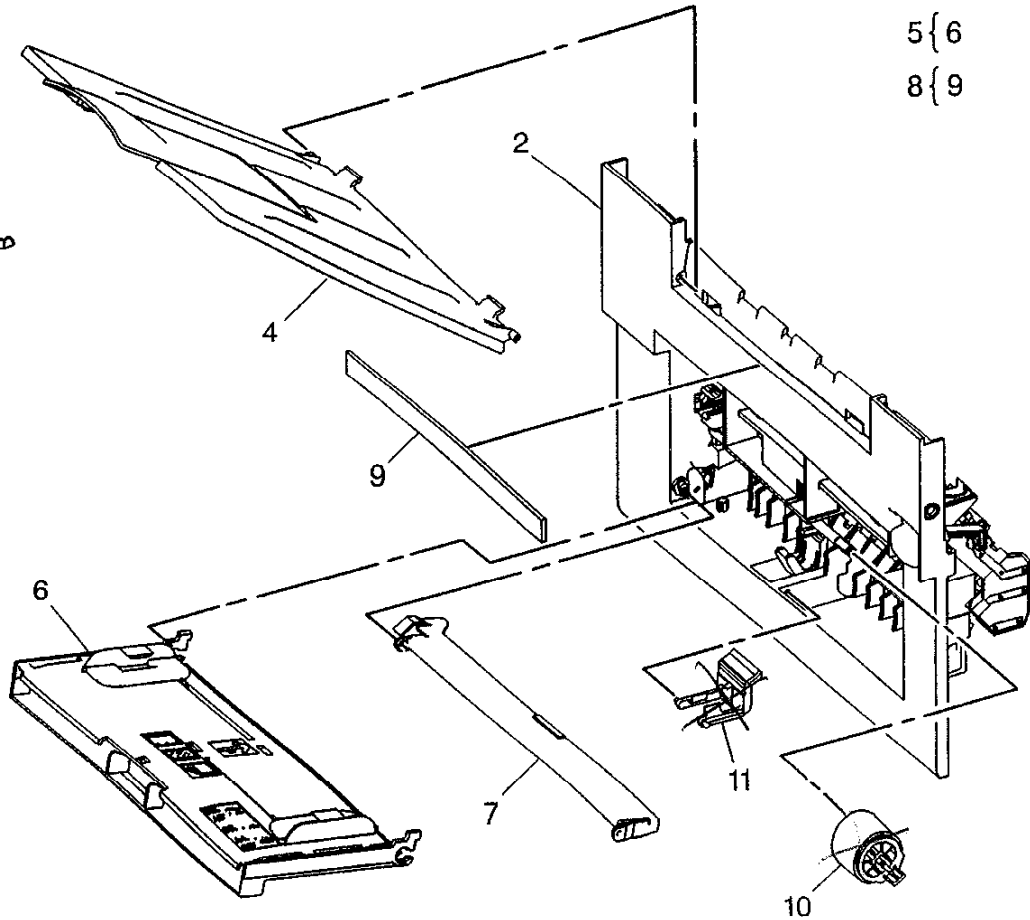

1 { 2, 7

3 { 4

5 { 6

8 { 9

0000003B-AFF

**PL 2.5 DOOR TRANSPORT COMPONENTS (PART 2 OF 2)**

Item	Part	Description
1	-	PART OF DOOR TRANSPORT MODULE KIT (REF: PL 2.3 item 2)
2	600K62952	DOOR LATCH KIT
3	-	LATCH (P/O PL 2.5 item 2)
4	-	DOOR FRAME (P/O PL 2.5 item 1)
5	-	DOOR CONNECTOR (P/O PL 2.5 item 1)
6	600K62861	BYPASS SIDE GUIDE GEAR KIT
7	-	SIDE GUIDE GEAR (P/O PL 2.5 item 6)
8	-	TETHER (P/O PL 2.5 item 1)
9	121E14620	BYPASS FEED SOLENOID (SOL3)
10	130K58602	REGISTRATION SENSOR (Q1) (REP 8.3)
11	600K70743	TRANSFER/DETACK COROTRON KIT
12	-	TRANSFER/DETACK COROTRON (P/O PL 2.5 item 11) (REP 8.5)
13	-	REGISTRATION ROLL (P/O PL 2.5 item 1)
14	600K70750	REGISTRATION CLUTCH KIT
15	-	REGISTRATION CLUTCH (CL1) (P/O PL 2.5 item 14)

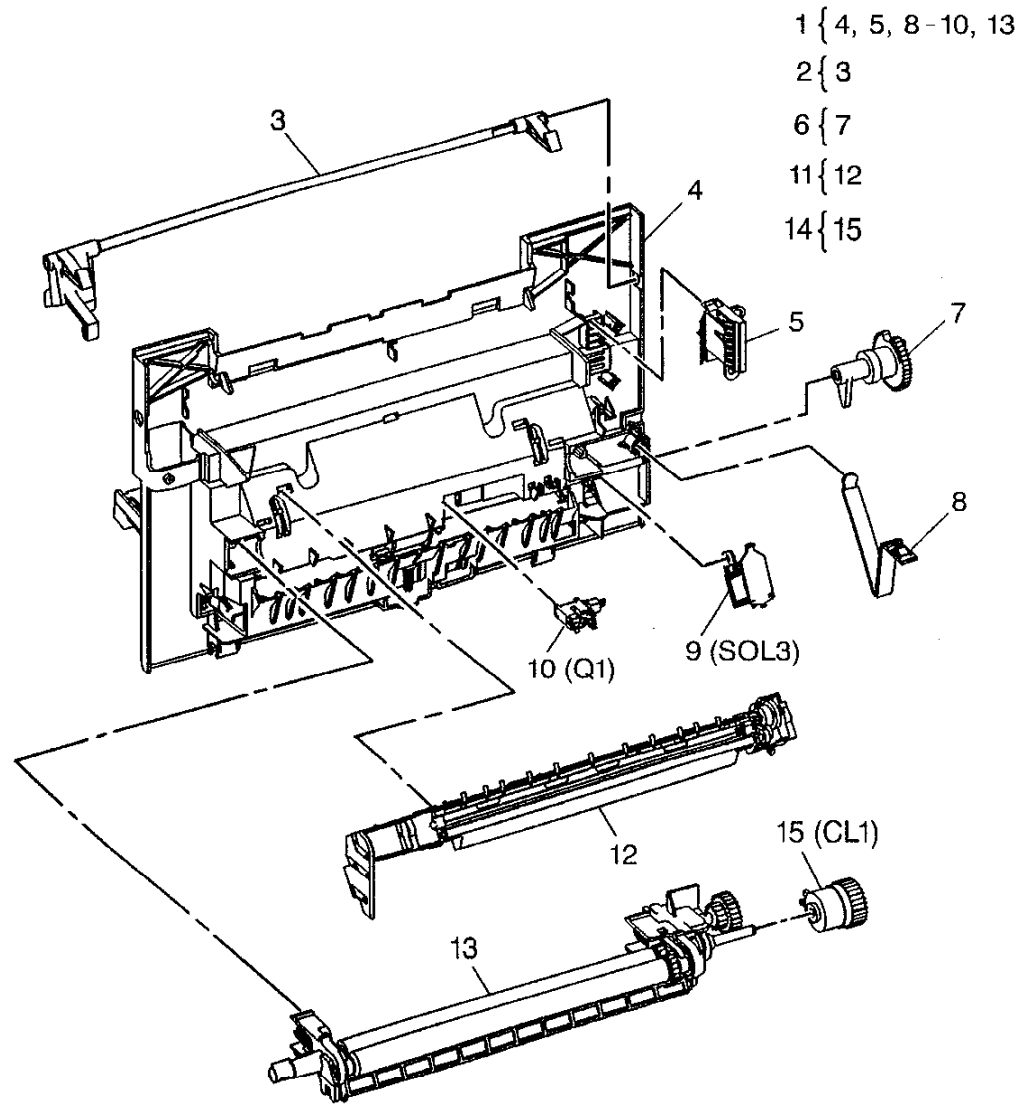

0000028-AFF

### PL 3.1 IMAGER COMPONENTS

Item	Part	Description
1	62K8723	IMAGER MODULE (USCO) (REP 6.1)
-	62K9300	IMAGER MODULE (XL) (REP 6.1)
2	90E2001	DOCUMENT GLASS (REP 14.1)
3	130E8430	SCAN HOME SENSOR (Q4)
4	-	IMAGER HOUSING (P/O PL 3.1 item 1)
5	122E2230	EXPOSURE LAMP (LP1) (REP 6.2)
6	62K8680	ROS (REP 6.3)
7	26E69590	CARRIAGE LOCKING SCREW

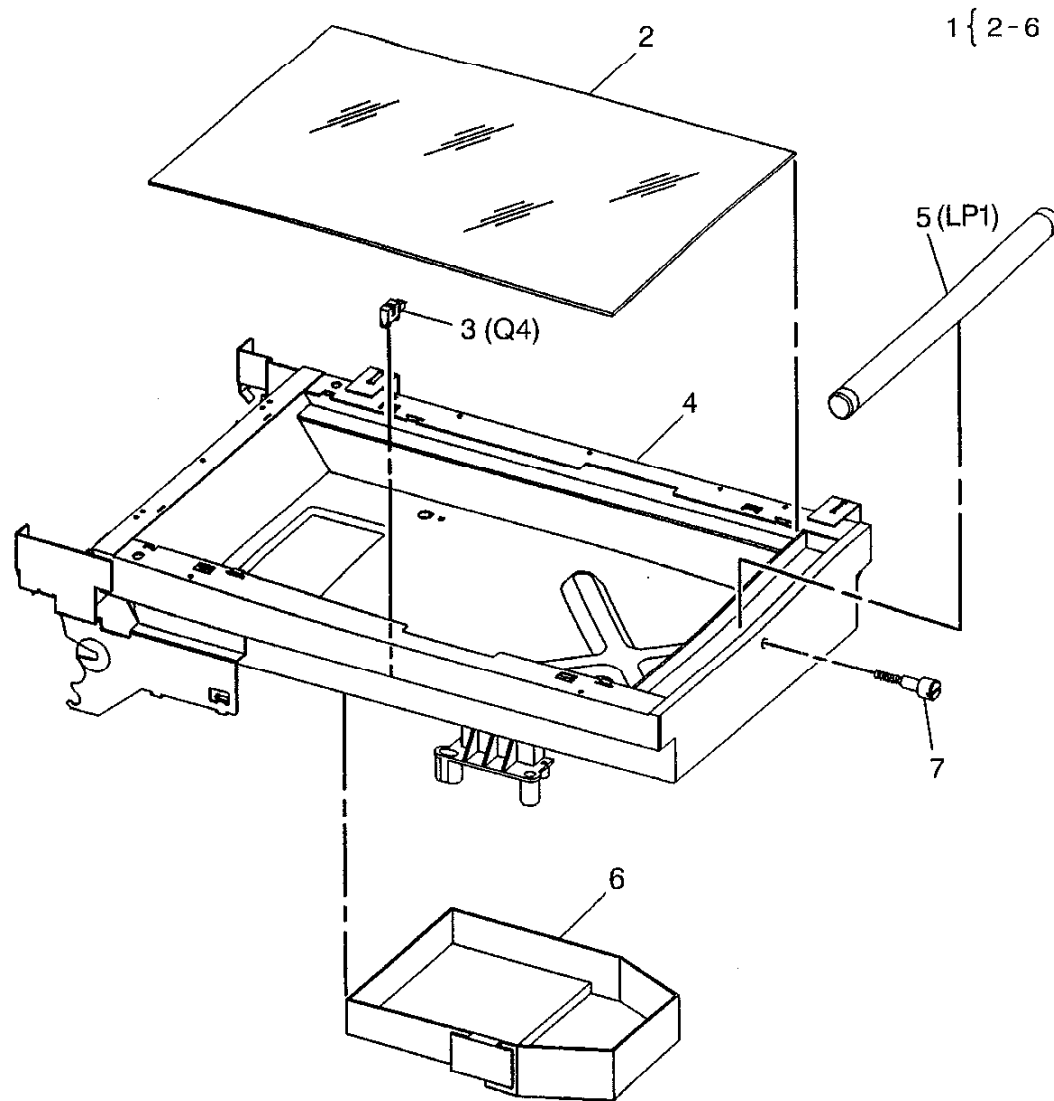

000009B-AFF

## PL 4.1 COPY CARTRIDGE MODULE

Item	Part	Description
1	113R180	COPY CARTRIDGE MODULE (SOLD EP/HARDSTOP) (ACO/USCO/XCL)(REP 9.1)
-	113R181	COPY CARTRIDGE MODULE (SOLD NON-EP/HARDSTOP) (USCO) (REP 9.1)
-	113R182	COPY CARTRIDGE MODULE (SOLD/HARDSTOP) (XL) (REP 9.1)
-	113R286	COPY CARTRIDGE MODULE (METERED/RUN TO LIFE) (XL) (REP 9.1)
2	-	IMAGER HOUSING (NOT SPARED)

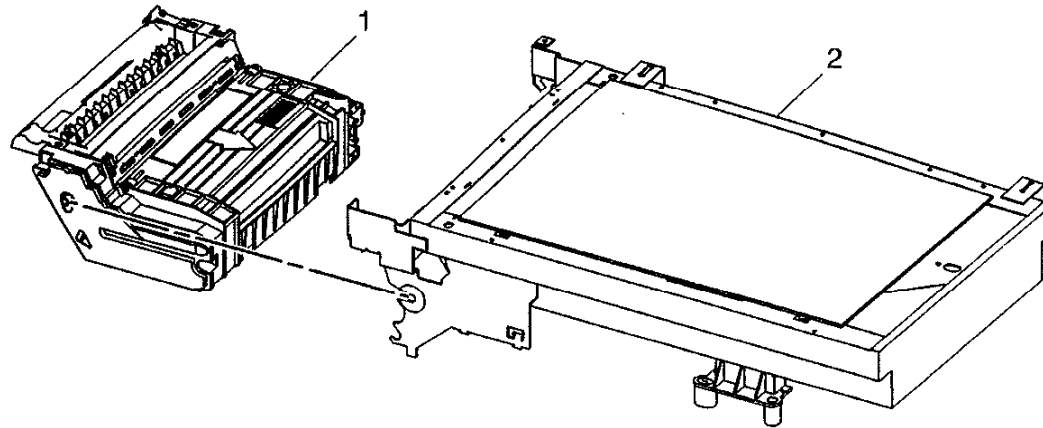

0000011A-AFF

## PL 5.1 FUSER MODULE

Item	Part	Description
1	600K62927	FUSER MODULE KIT (110V) (REP 10.1)
-	600K62936	FUSER MODULE KIT (220V) (REP 10.1)
2	-	IMAGER HOUSING (NOT SPARED)

*Cook72090 - CURL KIT*  
*- FUSER ASSY*  
*- OUTPUT TRAY SHIM*

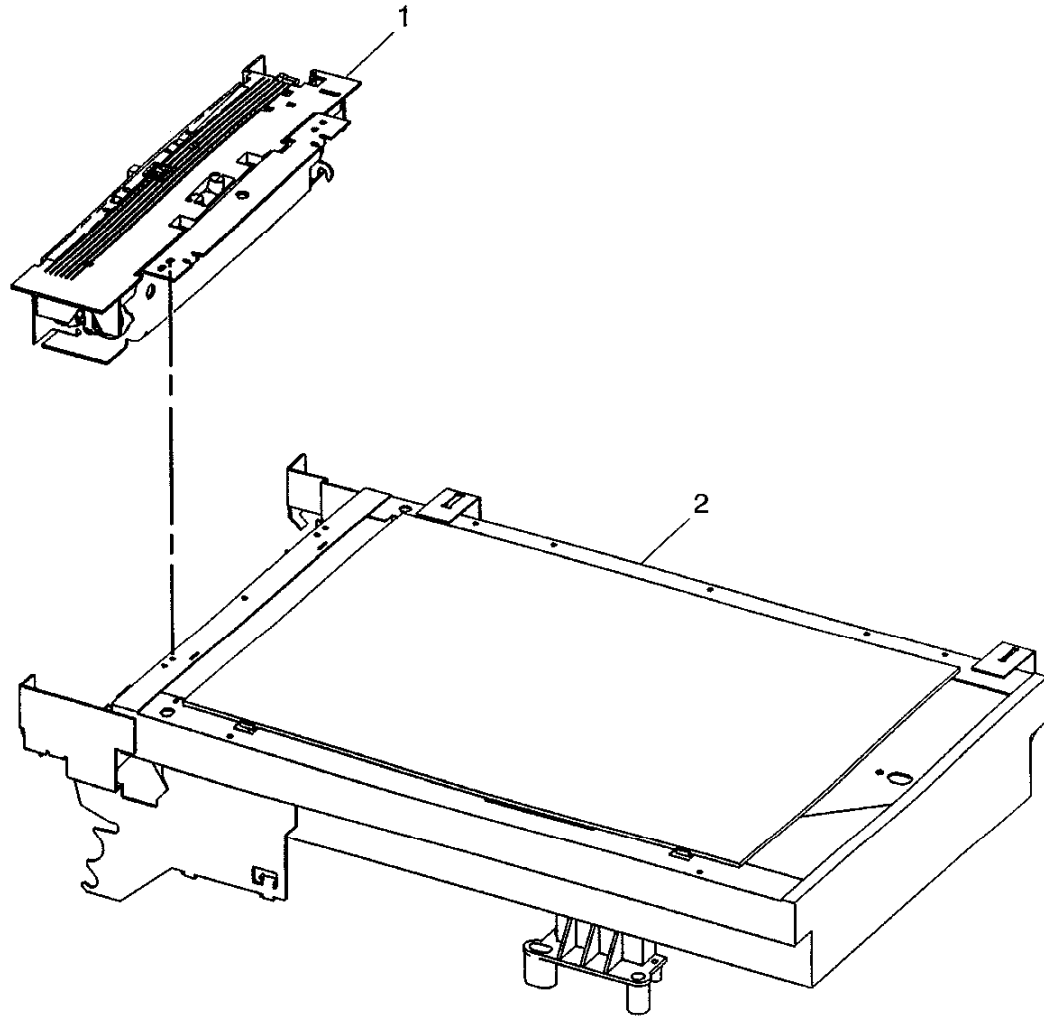

000010A-AFF

# PL 6.1 POWER/CONTROL MODULE (PCM) COMPONENTS

Item	Part	Description
1	600K70512	CONTROL CONSOLE 212/214 INCH LABEL KIT (REP 1.1)
-	600K70543	CONTROL CONSOLE 212/214 METRIC LABEL KIT (REP 1.1)
2	-	CONTROL CONSOLE LABEL (P/O PL 6.1 item 1)
3	-	CONTROL CONSOLE BEZEL (P/O PL 6.1 item 1)
4	-	PWB COVER (NOT SPARED)
5	160K55470	PRINTER PWB
6	-	INTERFACE PANEL (NOT SPARED)
7	160K55562	MAIN PWB (REP 1.2) (TAG: P-013)
8	-	PWB CLIP (NOT SPARED)
9	160K44650	INTERCONNECT PWB (REP 1.3)
10	160K37251	HVPS (REP 1.5)
11	160K37240	LVPS (110V) (REP 1.4)
-	160K39840	LVPS (220V) (REP 1.4)
12	-	POWER / CONTROL MODULE (NOT SPARED)
13	-	EEA PRINT SERVER (5VDC) (NOT SPARED)
14	-	AC/DC POWER CORD (NOT SPARED)
15	114E15900	HVPS CONTACTS (NOT SPARED)
16	117E18480	POWER CORD, 110V

600K71940 U4 Fix Kit  
 - 107.4 slw  
 - RWBA CLAMP. (ITEM 8)

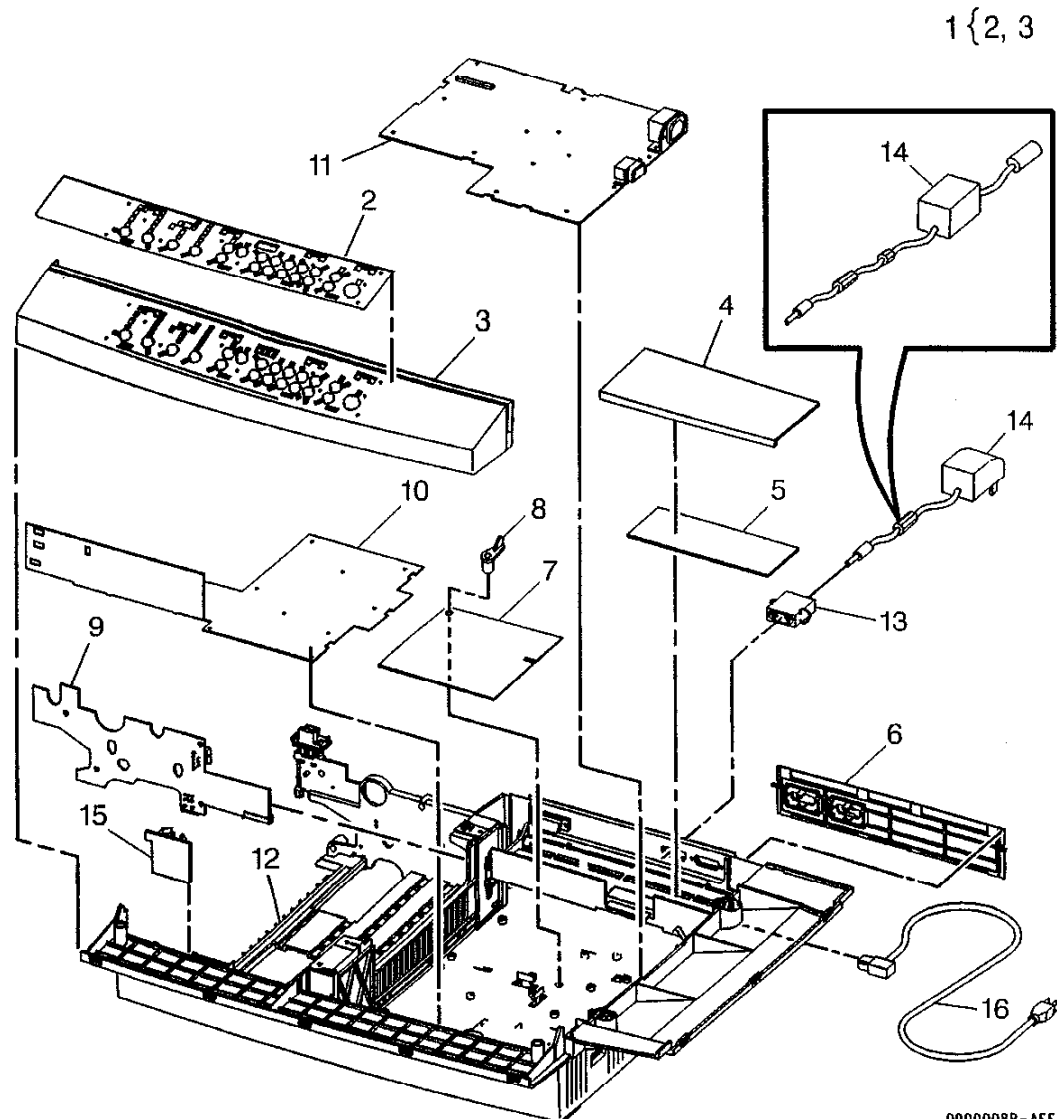

0000088-AFF



## PL 7.1 COVERS

Item	Part	Description
1	600K63033	DOCUMENT COVER KIT
2	-	DOCUMENT COVER (P/O PL 7.1 item 1)(REP 14.4)
3	600K62880	DOCUMENT COVER HINGE KIT
4	-	RIGHT HINGE (P/O PL 7.1 item 3)(REP 14.5)
5	-	LEFT HINGE (P/O PL 7.1 item 3)(REP 14.5)
6	600K63020	FUSER COVER KIT
7	-	FUSER COVER (P/O PL 7.1 item 6, PL 7.1 item 8) (REP 14.2)
8	48K56787	TOP COVER ASSEMBLY
9	-	TOP COVER (P/O PL 7.1 item 8) (REP 14.1)
10	600K63012	REAR COVER KIT
11	-	DRIVES COVER (P/O PL 7.1 item 10)(REP 14.3)
12	-	COPIER HOUSING (NOT SPARED)

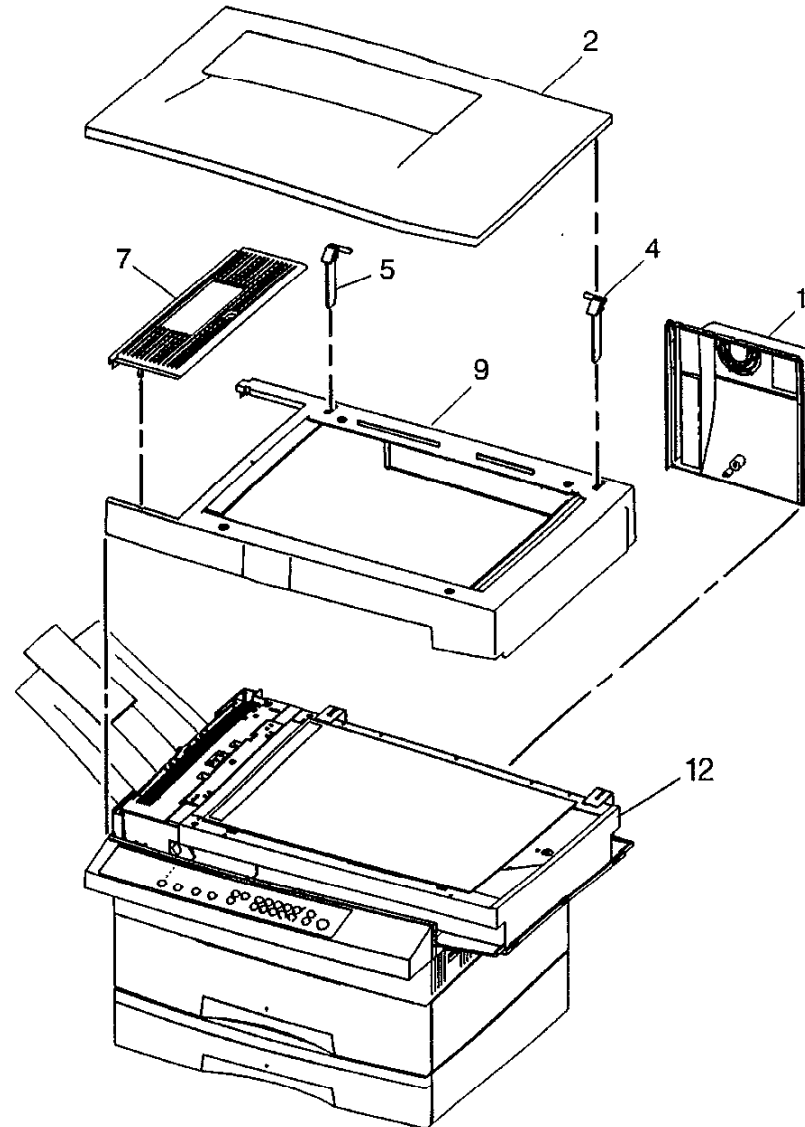

1 { 2  
 3 { 4, 5  
 6 { 7  
 8 { 7, 9  
 10 { 11

0000012B-AFF

## PL 8.1 SDF MODULE

Item	Part	Description
1	-	SDF MODULE ASSEMBLY (NOT SPARED) (REP 5.1)
2	-	COPIER HOUSING (NOT SPARED)

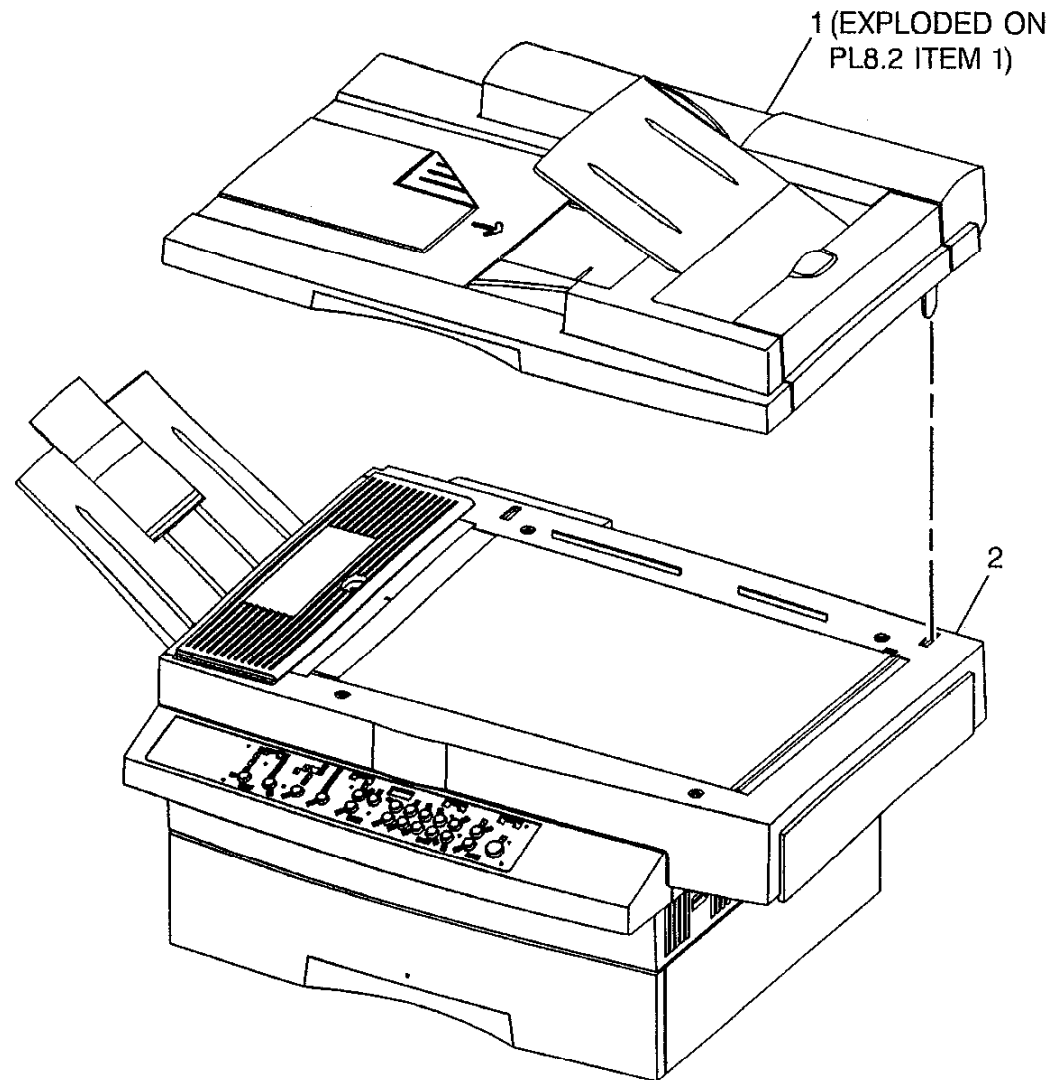

0000013A-AFF

## PL 8.2 SDF COMPONENTS

Item	Part	Description
1	-	PART OF SDF MODULE ASSEMBLY (REF: PL 8.1 item 1)
2	-	SDF DRIVES COVER (P/O PL 8.2 item 1)(REP 5.2)
3	22K60211	FEED ROLL
4	50E13701	SDF OUTPUT TRAY
5	160K32621	SDF PWB (REP 5.7)
6	121E10931	DOCUMENT FEED SOLENOID (SOL4) (REP 5.4)
7	107E94941	DOCUMENT PRESENT SENSOR (Q2) (REP 5.10) DOCUMENT REGISTRATION SENSOR (Q3) (REP 5.9)
8	127K22402	SDF DRIVE MOTOR (MOT3) (REP 5.8)
9	5K4431	DOCUMENT FEED CLUTCH (CL2)
10	-	SDF ACCESS DOOR (P/O PL 8.2 item 1)
11	-	SDF FEED TRANSPORT COVER (P/O PL 8.2 item 1) (REP 5.3)

1 { 2, 4-11

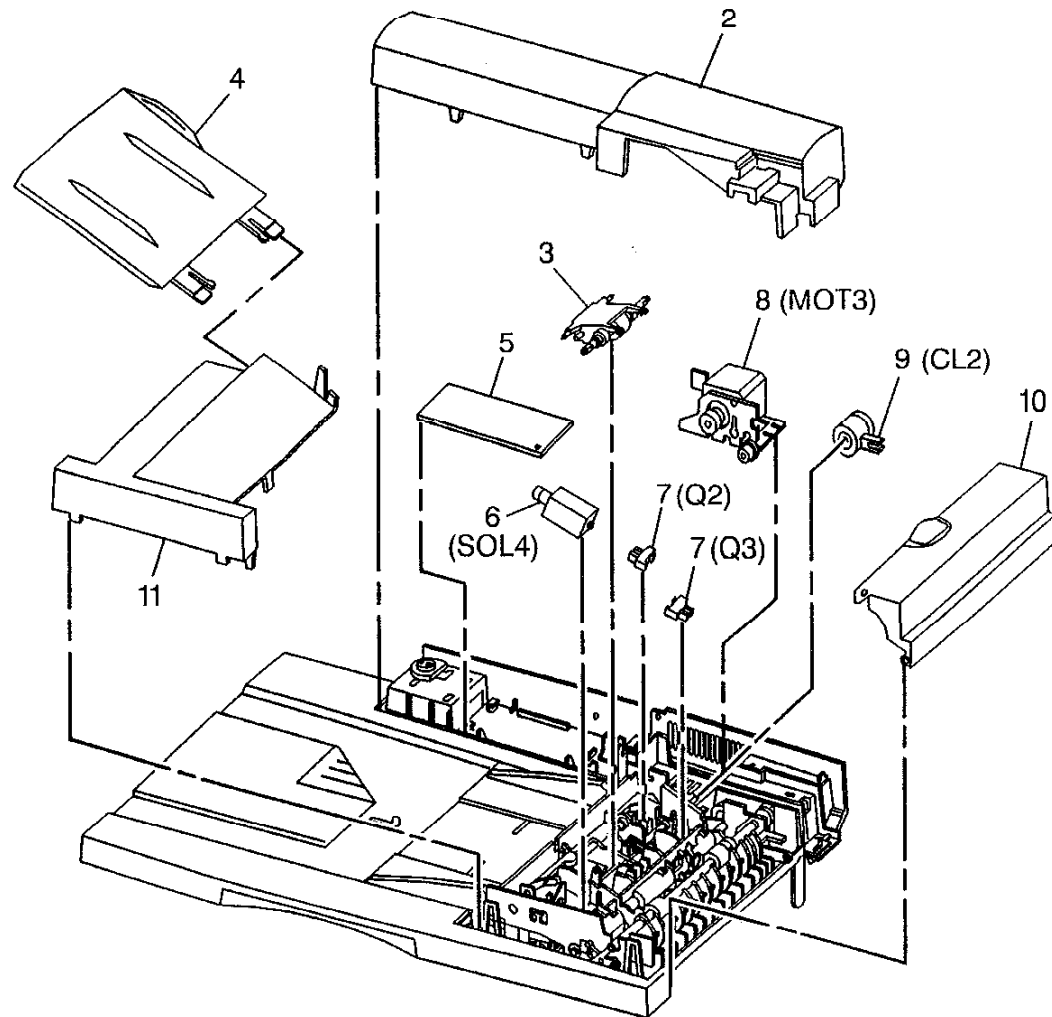

0000014B-AFF

# Part Number Index

Table 1 Part Number Index

Part Number	Part List
5K4431	PL 8.2
6E66580	PL 2.1
	PL 2.2
7K10024	PL 1.1
7K10120	PL 2.1
7K10130	PL 2.2
7K10140	PL 2.2
22K60211	PL 8.2
26E69590	PL 3.1
48K56787	PL 7.1
50E13701	PL 8.2
62K8680	PL 3.1
62K8723	PL 3.1
62K9300	PL 3.1
90E2001	PL 3.1
107E94941	PL 8.2
113R180	PL 4.1
113R181	PL 4.1
113R182	PL 4.1
113R286	PL 4.1
117E18480	PL 6.1
121E10931	PL 8.2
121E13870	PL 2.1
	PL 2.2
121E14620	PL 2.5
122E2230	PL 3.1
127K22402	PL 8.2
130E8430	PL 3.1
130K58602	PL 2.5
160K32621	PL 8.2
160K37240	PL 6.1
160K37251	PL 6.1
160K39840	PL 6.1
160K44650	PL 6.1
160K55470	PL 6.1
160K55562	PL 6.1
600K62850	PL 2.1
	PL 2.2
600K62861	PL 2.5

Table 1 Part Number Index

Part Number	Part List
600K62880	PL 7.1
600K62890	PL 2.1
600K62900	PL 2.1
	PL 2.2
600K62910	PL 2.2
600K62927	PL 5.1
600K62936	PL 5.1
600K62943	PL 2.3
600K62952	PL 2.5
600K62970	PL 2.4
600K62983	PL 2.4
600K62990	PL 1.2
600K63012	PL 7.1
600K63020	PL 7.1
600K63033	PL 7.1
600K63040	PL 2.2
600K63051	PL 2.2
600K64100	PL 2.2
600K70512	PL 6.1
600K70543	PL 6.1
600K70743	PL 2.5
600K70750	PL 2.5
600K71890	PL 2.4