

# SHARP PARTS GUIDE

CODE:00ZAR6023NP02

## デジタル複合機 DIGITAL MULTIFUNCTIONAL SYSTEM

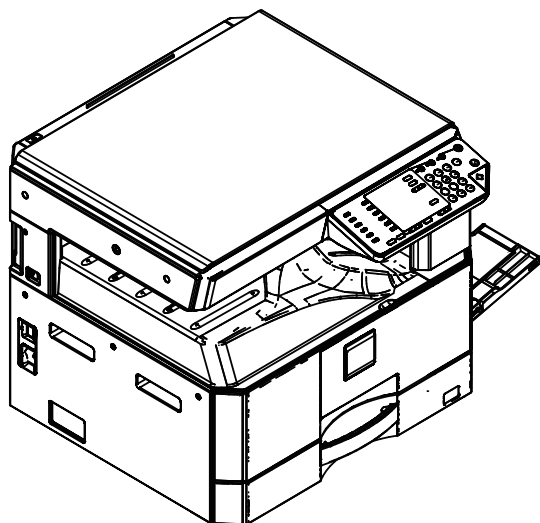

AR-6031N/AR-6031NR  
AR-6131/AR-X311N  
AR-6026N/AR-6026NR  
AR-6023N/AR-6023NR  
AR-X231N/AR-6020N  
AR-6020NR/AR-6120N  
AR-6023D/AR-6020D  
AR-X201D/AR-6023  
AR-6020/AR-X201  
AR-G200  
AR-RP11/MX-VR12

## MODEL AR-NB7/AR-NB7R

このパーツガイドに掲載されている表示価格ランクは消費税抜きです。

### CONTENTS

- ① 外装 (Exteriors)
- ② 操作パネル (Operation Panel)
- ③ RSPF 外装・搬送 (Exteriors, Transport)  
[AR-6131N,AR-6120N,AR-RP11]
- ④ RSPF 給紙・原稿トレイ (Paper feed, Original tray)  
[AR-6131N,AR-6120N,AR-RP11]
- ⑤ RSPF 搬送部 (Paper transfer section)  
[AR-6131N,AR-6120N,AR-RP11]
- ⑥ RSPF ベーストレイ (Base tray)  
[AR-6131N,AR-6120N,AR-RP11]
- ⑦ RSPF 駆動部 (Drive section)  
[AR-6131N,AR-6120N,AR-RP11]
- ⑧ スキャナユニット 1(Scanner Unit 1)
- ⑨ スキャナユニット 2(Scanner Unit 2)
- ⑩ ランプユニット (Lamp unit)
- ⑪ プロセスユニット (Process unit)  
[AR-6031N,AR-6031NR,AR-6131N,AR-X311N,AR-6026N,  
AR-6026NR]
- ⑫ プロセスユニット (Process unit)  
[AR-6023N,AR-6023NR,AR-X231N,AR-6020N,AR-6020NR,  
AR-6120N,AR-6023D,AR-6020D,AR-X201D,AR-6023,  
AR-6020,AR-X201]
- ⑬ DV ユニット (DV unit)
- ⑭ 定着ユニット (Fusing unit)  
[AR-6031N,AR-6031NR,AR-6131N,AR-X311N,AR-6026N,  
AR-6026NR]
- ⑮ 定着ユニット (Fusing unit)  
[AR-6023N,AR-6023NR,AR-X231N,AR-6020N,AR-6020NR,  
AR-6120N,AR-6023D,AR-6020D,AR-X201D,AR-6023,  
AR-6020,AR-X201]
- ⑯ メイン駆動ユニット (Main drive unit)
- ⑰ 550 枚トレイユニット (550 paper tray unit)  
[AR-6031N,AR-6031NR,AR-6131N,AR-X311N,AR-6026N,  
AR-6026NR]
- ⑱ 250 枚トレイユニット (250 paper tray unit)  
[AR-6023N,AR-6023NR,AR-X231N,AR-6020N,AR-6020NR,  
AR-6120N,AR-6023D,AR-6020D,AR-X201D,AR-6023,  
AR-6020,AR-X201]
- ⑲ 給紙ユニット (Paper Feed Unit)  
[AR-6031N,AR-6031NR,AR-6131N,AR-X311N,AR-6026N,  
AR-6026NR]
- ⑳ 2nd 給紙ユニット (2nd paper Feed Unit)  
[AR-6031N,AR-6031NR,AR-6131N,AR-X311N,AR-6026N,  
AR-6026NR]
- ㉑ 2nd ユニット (2nd unit)  
[AR-6031N,AR-6031NR,AR-6131N,AR-X311N,AR-6026N,  
AR-6026NR]
- ㉒ 手差しマルチユニット (MF unit)
- ㉓ サイドドアユニット (side door unit)
- ㉔ 転写ローラーユニット (Transcer roller unit)
- ㉕ 排紙フレーム (Delivery unit)
- ㉖ PS ユニット (PS unit)
- ㉗ フレームセクション 1(Frame section 1)
- ㉘ フレームセクション 2(Frame section 2)
- ㉙ フレームセクション 3(Frame section 3)  
[AR-6031N,AR-6031NR,AR-6131N,AR-X311N,AR-6026N,  
AR-6026NR]
- ㉚ フレームセクション 3(Frame section 3)  
[AR-6023N,AR-6023NR,AR-X231N,AR-6020N,AR-6020NR,  
AR-6120N,AR-6023D,AR-6020D,AR-X201D,AR-6023,  
AR-6020,AR-X201]
- ㉛ フレームセクション 4(Frame section 4)
- ㉜ ハーネス部 (Harness section)
- ㉝ ワイヤースドル・クランプ (Wire saddle, Clamp)
- ㉞ 付属品 (Accessories)

## 仕向地インデックス (Destination index)

マトリックスに記載している地域名について、各々の国がどの地域に該当するかは、下記表を参照する事。

Regarding the name of regions listed on matrix, refer to the table below to figure out which country belongs to which region.

Classification by the large area (大分類)	Classification by the small area (小分類)	Country(国)	Classification by the voltage	Classification by the Paper standard
Japan(日本)	Japan(日本)	Japan(日本)	100V	AB series
Americas	Americas1	Mexico / LAG(120V)	120V	Inch series
Europe	Europe1	Germany / Spain / France / Italy / The Netherlands / Switzerland	220-240V	AB series
		U.kingdom	220-240V	AB series
		Sweden / Denmark / Finland / Norway	220-240V	AB series
	Europe2	Greek / Cyprus / Turkish / Polish / Hungarian / Czech / Slovak	220-240V	AB series
		Romania / Latvia / Portugal	220-240V	AB series
	Europe3	Russia	220-240V	AB series
Australia	Australia	Australia / New Zealand	220-240V	AB series
Asia	Asia1	Hong Kong / Thailand /India	220-240V	AB series
	Asia2	Singapore / Malaysia / Vietnam	220-240V	AB series
	Asia3	Philippines	220-240V	Inch series
	Asia4	Saudi Arabia /Yemen / Bahrain / Kuwait / UAE / Oman / Qatar	220-240V	AB series
	Asia6	Pakistan / Nigeria / Jordan / Tunisia / Morocco / West Africa / Egypt	220-240V	AB series
	Asia10	Iran	220-240V	AB series
Class B	Class B	South Africa / Namibia	220-240V	AB series
		Brazil	120V	AB series
		Taiwan	110V	AB series

## 補修部品のランク付

市場における補修部品の在庫管理が、適正に運営出来る手助けとなることを、目的とします。

Aランク：メンテナンスパーツ、メンテナンスパーツには入っていないがメンテナンスパーツに近い消耗パーツ。

Bランク：性能・機能パーツ（センサー、クラッチ等の電気パーツ）、消耗パーツ。

Eランク：基板含むユニットパーツ。

Dランク：整備パーツ（外装、パッキング、同梱パーツ）。

Cランク：上記ランク以外のパーツ（基板の子部品を除いたもの）。

## DEFINITION

Rank A：Maintenance parts, and consumable parts which are not included in but closely related to maintenance parts

Rank B：Performance/function parts (sensors, clutches, and other electrical parts), consumable parts

Rank E：Unit parts including PWB

Rank D：Preparation parts (External fitting, packing, parts packed together)

Rank C：Parts other than the above (excluding sub components of PWB)

安全性・信頼性確保のため部品は、必ず正規のものをご使用下さい。

△印の商品は、安全上重要な部品です。交換をする時は、安全及び性能維持のため必ず指定の部品をご使用下さい。

Because parts marked with "△" is indispensable for the machine safety maintenance and operation, it must be replaced with the parts specific to the product specification.

○ 当モデルのサービス資料には、この資料以外にサービスマニュアルがあります。合わせてご利用下さい。

○ Other than this Parts Guide, please refer to documents Service Manual of this model.

○ Please use the 13 digit code described in the right hand corner of front cover of the document, when you place an order.

○ For U.S. only-Use order codes provided in advertising literature. Do not order from parts department.

## [NOTE]

PRICE RANK: \* These parts are supplied by SMF.

## <修正パーツガイド活用時の注意>

・ 部品の互換性は下表の通り、No1 ～ 6 で表現しております。

### < 互換性 >

1	新・旧の互換性有り。
2	新の代わりに旧は使用可。旧の代わりに新は使用不可。
3	新の代わりに旧は使用不可。旧の代わりに新は使用可。
4	新・旧の互換性無。
5	旧 (a,b,c...) どうし一対、又は、新 (a,b,c...) どうし一対で、互換性有。
6	その他

・ 部品の追加・変更・廃止・員数の増減等の変更は下表のマークで表現しております。

### < 変更区分 >

新規追加		員数増・その他	☆
変更		員数減	★
廃止		パーツ修正	

・ 変更時期のランニングチェンジは、RC として記載しています。

### < 変更時期 >

RC	ランニングチェンジ
----	-----------

### <Reason for Change / 変更理由 >

英文	和文
[Missing parts code]	パーツコード記載漏れ
[Commonization]	共通化
[Improve performance]	性能向上
[Carried-out timing change]	実施時期変更
[Productivity improvement]	生産性向上
[Specification change]	仕様変更
[Parts code correction]	パーツコード訂正
[Change supply form]	供給形態変更

## <Note for use of the revised Parts Guide>

・ Interchangeability of parts is expressed by No1~6 as shown in the table below.

### <Interchangeability>

1	Interchangeable.
2	Current type can be used in place of new type. New type cannot be used in place of current type.
3	Current type cannot be used in place of new type. New type can be used in place of current type.
4	Not interchangeable.
5	Interchangeable if replaced with same types of related parts in use.
6	Others

・ New & Addition, Change, Abolition, and Quantity change are expressed with the marks shown in the table below.

### <Change of Division>

New & Addition		Q'antity (increase) Other	☆
Change		Q'antity (decrease)	★
Abolition		Correction	

Running Change of Effective Time is expressed as RC.

### <Effective Time>

RC	Running Change
----	----------------

1 外装 (Exteriors)

NO.	PARTS CODE	Inter-change	PRICE Ex.	RANK Ja.	NEW MARK	PART RANK	DESCRIPTION	Reason for change	Effective time
1	LSOU-0074QSZZ		BC	GJ	N	D	Delivery tray 排紙トレイ		
	LSOU-0074QSAZ	-	BC	GJ	N	D	Delivery tray 排紙トレイ	Parts code correction	1st lot
2	XEBS740P08000		AA	DD		C	Screw(4x8) ビス		
3	GCOVA0122QSZZ		BB	GD	N	D	OC cover OCカバー		
	MHNG-0039QSZZ		AT	EZ	N	D	OC hinge OCヒンジ		
4	MHNG-0039QSZ1	3	AT	EZ	N	D	OC hinge OCヒンジ	Improve performance	14/Nov
5	XEBS740P10000		AA	DD		C	Screw(4x10) ビス		
6	PCUSS0035QSZZ		AT	EZ	N	D	OC mat OCマット		
7	DUNT-1222RSZZ		BC	GD	N	E	Table glass unit テーブルガラスユニット		
8	LFIX-0695FCAZ		AR	EQ	N	D	Glass fixing plate left OC [AR-6031N,AR-6031NR,AR-X311N,AR-6026N,AR-6026NR,AR-6023N,AR-6023NR,AR-X231N,AR-6020N,AR-6020NR,AR-6023D,AR-6020D,AR-X201D,AR-6023,AR-6020,AR-X201,AR-G200]	ガラス押え左 OC	
9	LFIX-0683FCBZ		AL	EB	N	D	Glass fixing plate right ガラス押え右		
10	GCOVA0136QSZ1		BC	GD	N	D	Main rear cover(Refer to Matrix) メイン後カバー		
	GCOVA0136QSZ4	-	BC	GD	N	D	Main rear cover(Refer to Matrix) メイン後カバー	Parts code correction	1st lot
	GCOVA0136QSZ5	-	BC	GD	N	D	Main rear cover(Refer to Matrix) メイン後カバー	Parts code correction	1st lot
	GCOVA0136QSZ8	3	BC	GD	N	D	Main rear cover(Refer to Matrix) メイン後カバー	Improve performance	14/Dec
	GCOVA0136QSZ9	3	BC	GD	N	D	Main rear cover(Refer to Matrix) メイン後カバー	Improve performance	14/Dec
	GCOVA0136QSZD	3	BC	GD	N	D	Main rear cover(Refer to Matrix) メイン後カバー	Improve performance	15/Jan
	GCOVA0136QSZE	3	BC	GD	N	D	Main rear cover(Refer to Matrix) メイン後カバー	Improve performance	15/Jan
	GCOVA0136USZD	1			N	D	Main rear cover(Refer to Matrix) メイン後カバー	Productivity improvement	15/May
GCOVA0136USZE	1			N	D	Main rear cover(Refer to Matrix) メイン後カバー	Productivity improvement	15/May	
11	XHBS740P08000		AA	DD		C	Screw(4x8) ビス		
12	GCOVA0114QSZZ		AX	FG	N	D	Right cover(Refer to Matrix) 右カバー		
	GCOVA0114QSZ1	-	AX	FG	N	D	Right cover(Refer to Matrix) 右カバー	Parts code correction	1st lot
	GCOVA0142QSZZ	1	AW	FG	N	D	Right cover(Refer to Matrix) 右カバー	Productivity improvement	15/Apr RC
13	XHBS730P06000		AC	DD		C	Screw(3x6) ビス		
14	GCAB-0233QSZZ		AN	EQ	N	D	Right sub cabinet 右サブキャビネット		
15	GCAB-0224QSZZ		AM	EG	N	D	Delivery tray right 排紙トレイ右		
16	GCAB-0226QSZZ		AK	DX	N	D	Front cabinet right 前キャビネット右		
17	GCAB-0228QSZZ		AU	EZ	N	D	Main front cabinet right メイン前キャビネット右		
	GCAB-0228QSZ1	3	AU	EZ	N	D	Main front cabinet right メイン前キャビネット右	Specification change	14/Nov RC
18	GCAB-0228QSZ2	3			N	D	Main front cabinet right メイン前キャビネット右	Improve performance	15/Feb
	LFRM-0160QSZ1		AV	FG	N	C	Front inner frame(Refer to Matrix) 前インナーフレーム		
19	LFRM-0160QSZ2		AV	FG		C	Front inner frame(Refer to Matrix) 前インナーフレーム		
	GCAB-0227QSZZ		AQ	EQ	N	D	Main front cabinet left メイン前キャビネット左		
20	GCAB-0227QSZ1	-	AQ	EQ	N	D	Main front cabinet left メイン前キャビネット左	Parts code correction	1st lot
21	GCAB-0225QSZZ		AK	DX	N	D	Front cabinet left 前キャビネット左		
	GCOVA0116QSZZ		AY	FQ	N	D	Left cover 左カバー		
22	GCAB-0225QSZ1	3	AY	FQ	N	D	Left cover 左カバー	Productivity improvement	14/Dec RC
	GCOVA0133QSZZ		AP	EQ	N	D	Scanner front cover left スキャナー前カバー左		
23	GCAB-0228QSZ1	-	AP	EQ	N	D	Scanner front cover left スキャナー前カバー左	Parts code correction	1st lot
	GCOVA0115QSZZ		AT	EZ	N	D	Scanner left cover スキャナー左カバー		
24	GCAB-0229QSZZ		AS	EQ	N	D	Scanner left cover スキャナー左カバー	Parts code correction	1st lot
25	GCAB-0229QSZ1	-	AT	EZ	N	D	Scanner left cover スキャナー左カバー	Parts code correction	1st lot
26	GCAB-0229QSZ2		AS	EQ	N	D	Delivery rear cabinet 排紙後キャビネット		
27	XBTS740P06000		AA	DD		C	Screw(4x6) ビス		
28	XEBS730P08000		AC	DD		C	Screw(3x8) ビス		
29	LX-BZ0088QSPZ		AA	DD		C	Screw(3x6) ビス		
30	GCAB-0234QSZZ		AT	EZ	N	D	Upper cabinet rear 上キャビネット後		
31	GCAB-0230QSZ1		AH	DX	N	D	Scanner left cover lower(Refer to Matrix) スキャナー左カバー下		
	GCAB-0230QSZ2		AH	DX	N	D	Scanner left cover lower(Refer to Matrix) スキャナー左カバー下		
32	PMLT-2173FCZZ		AD	DD		C	Dust proof molt 防塵マット		
33	GCOVA0134QSZZ		AV	FG	N	D	Scanner front cover right スキャナー前カバー右		
33	TCAUA1080FCZZ		AD	DJ		D	Service caution label [Americas1,Europe,Australia,Asia,Class B] サービス注意ラベル		
	CBDGD0008QS06		AL	EB	N	D	Model name plate(Refer to Matrix) 機種名プレート		
	CBDGD0008QS07		AL	EB	N	D	Model name plate(Refer to Matrix) 機種名プレート		
	CBDGD0008QS08		AL	EB	N	D	Model name plate(Refer to Matrix) 機種名プレート		
	CBDGD0008QS09		AL	EB	N	D	Model name plate(Refer to Matrix) 機種名プレート		
	CBDGD0008QS10		AL	EB	N	D	Model name plate(Refer to Matrix) 機種名プレート		
	CBDGD0008QS11		AL	EB	N	D	Model name plate(Refer to Matrix) 機種名プレート		
	CBDGD0008QS20		AL	EB	N	D	Model name plate(Refer to Matrix) 機種名プレート		
	CBDGD0008QS18		AL	EB	N	D	Model name plate(Refer to Matrix) 機種名プレート		
	CBDGD0008QS19		AL	EB	N	D	Model name plate(Refer to Matrix) 機種名プレート		
CBDGD0008QS22				N	D	Model name plate(Refer to Matrix) 機種名プレート			
CBDGD0008QS23		AM	EG	N	D	Model name plate(Refer to Matrix) 機種名プレート			



# 1 外装 (Exteriors)

NO.	PARTS CODE	Inter-change	PRICE RANK		NEW MARK	PART RANK	DESCRIPTION	Reason for change	Effective time
			Ex.	Ja.					
33	CBDGD0008QS24		AM	EG	N	D	Model name plate(Refer to Matrix) 機種名プレート		
	CBDGD0008QS25		AM	EG	N	D	Model name plate(Refer to Matrix) 機種名プレート		
	CBDGD0008QS26		AL	EB	N	D	Model name plate(Refer to Matrix) 機種名プレート		
	CBDGD0008QS27		AZ	FX	N	D	Model name plate(Refer to Matrix) 機種名プレート		
34	QEARP0288FCZZ		AC	DJ		C	Earth terminal base アース端子台		
35	TLABH1000QSZZ		AF	DS		D	Operation instruction label(Refer to Matrix) 操作説明ラベル		
	TLABH1001QSZZ		AW	FG	N	D	Operation instruction label(Refer to Matrix) 操作説明ラベル		
36	PSHEZ0897QSZZ		AC	DD		C	Hinge sheet ヒンジマイラー		
37	TLABZ1007QSZZ		AW	FG	N	D	Power supply label [Japan(日本)] 電源ラベル		
38	TLABZ1008QSZZ		AW	FG	N	D	Heater label [Japan(日本)] ヒーターラベル		
39	TLABH5200FCZZ		AB	DJ		D	Plug caution label [Japan(日本)] プラグ警告ラベル		
40	LFIX-0698FCA1		AK	DX		C	Glass fixing plate left ガラス押え左		
41	PGLSP0109FCZ1		BB	GD		C	SPF slit glass SPF スリットガラス		
42	PSHEZ5366FCZZ		AB	DJ		C	White correction sheet 白補正シート		
43	PSHEZ5971FCZZ		AA	DJ		C	SPF glass sheet SPF ガラスシート		
44	PGUMS0283FCZ2		AA	DJ		C	Table glass gum テーブルガラスゴム		
45	PSHEZ5367FCZ1		AC	DJ		C	SPF glass fixing sheet R SPF ガラス固定シートR		
46	PSHEZ5368FCZ1		AD	DJ		C	SPF glass fixing sheet L SPF ガラス固定シートL		
501	DUNT-9017FC13		AY	FQ		E	SPF glass unit SPF ガラスユニット		

## Matrix

No.10		メイン後カバー (Main rear cover)																			
PARTS CODE		AR-6031N	AR-6031NR	AR-6131N	AR-X311N	AR-6026N	AR-6026NR	AR-6023N	AR-6023NR	AR-X231N	AR-6020N	AR-6020NR	AR-6120N	AR-6023D	AR-6020D	AR-X201D	AR-6023	AR-6020	AR-X201	AR-G200	
		Americas1 Brazil	Europe Asia Class B	Americas1 Brazil	Europe Australia Asia Class B	Japan(日本)															
GCOVA0136QSZ1								Correction	Correction												
GCOVA0136QSZ4								1st Lot												1st Lot	
GCOVA0136QSZ5																					
GCOVA0136QSZ8																					
GCOVA0136QSZ9																					
GCOVA0136QSZD	1st Lot																				15/Jan
GCOVA0136QSZE																					15/Jan
GCOVA0136USZD	15/May																				
GCOVA0136USZE																					15/May

No.12		右カバー (Right cover)																			
PARTS CODE		AR-6031N	AR-6031NR	AR-6131N	AR-X311N	AR-6026N	AR-6026NR	AR-6023N	AR-6023NR	AR-X231N	AR-6020N	AR-6020NR	AR-6120N	AR-6023D	AR-6020D	AR-X201D	AR-6023	AR-6020	AR-X201	AR-G200	
		Americas1 Brazil	Europe Asia Class B	Americas1 Brazil	Europe Australia Asia Class B	Japan(日本)															
GCOVA0114QSZZ																					
GCOVA0114QSZ1																					Correction
GCOVA0142QSZZ	1st Lot																				1st Lot
																					15/Apr RC

No.18		前インナーフレーム (Front inner frame)																			
PARTS CODE		AR-6031N	AR-6031NR	AR-6131N	AR-X311N	AR-6026N	AR-6026NR	AR-6023N	AR-6023NR	AR-X231N	AR-6020N	AR-6020NR	AR-6120N	AR-6023D	AR-6020D	AR-X201D	AR-6023	AR-6020	AR-X201	AR-G200	
		Americas1 Brazil	Europe Asia Class B	Americas1 Brazil	Europe Australia Asia Class B	Japan(日本)															
LFRM-0160QSZ1																					1st Lot
LFRM-0160QSZ2	1st Lot																				

# 1 外装 (Exteriors)

No.29		スキャナ左カバー下 (Scanner left cover lower)	
PARTS CODE	AR-6031N AR-6031NR AR-6131N AR-6131N AR-X311N AR-6026N AR-6026NR AR-6023N AR-6023NR AR-X231N AR-6020N AR-6020NR AR-6120N		AR-6023D AR-6020D AR-X201D AR-6023 AR-6020 AR-X201 AR-G200
GCAB-0230QSZ1	1st Lot		
GCAB-0230QSZZ			1st Lot

No.33		機種名プレート (Model name plate)													
PARTS CODE	AR-6031N AR-6031NR	AR-6131N AR-6131N	AR-X311N	AR-6026N AR-6026NR	AR-6023N AR-6023NR	AR-X231N	AR-6020N AR-6020NR	AR-6120N	AR-6023D	AR-6020D	AR-X201D	AR-6023	AR-6020	AR-X201	AR-G200
CBDGD0008QS06															1st Lot
CBDGD0008QS07					1st Lot										
CBDGD0008QS08												1st Lot			
CBDGD0008QS09									1st Lot						
CBDGD0008QS10									1st Lot						
CBDGD0008QS11							1st Lot								
CBDGD0008QS18				1st Lot											
CBDGD0008QS19	1st Lot														
CBDGD0008QS20															1st Lot
CBDGD0008QS22								1st Lot							
CBDGD0008QS23														1st Lot	
CBDGD0008QS24											1st Lot				
CBDGD0008QS25						1st Lot									
CBDGD0008QS26			1st Lot												
CBDGD0008QS27		1st Lot													

No.35		操作説明ラベル (Operation instruction label)	
PARTS CODE	Americas1 Europe Australia Asia Class B		Japan (日本)
TLABH1000QSZZ	1st Lot		
TLABH1001QSZZ			1st Lot

# 1 外装 (Exteriors)

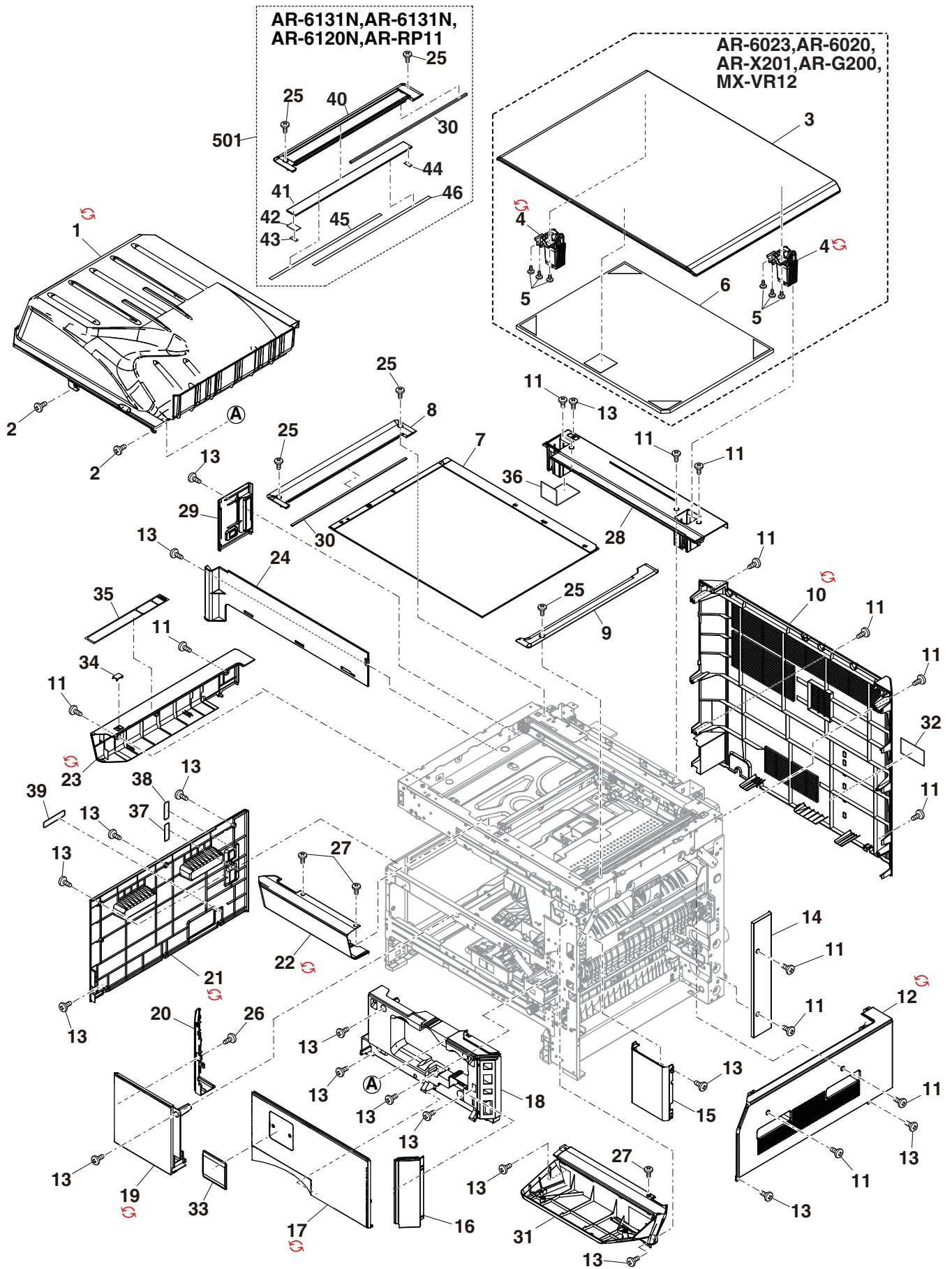

## 2 操作パネル (Operation Panel)

NO.	PARTS CODE	Inter-change	PRICE Ex.	RANK Ja.	NEW MARK	PART RANK	DESCRIPTION	Reason for change	Effective time
1	CPWBF0302QS31		BG	GT	N	E	OPE PWB	OPE 基板	
2	LHLZ0271QSZZ		AC	DD	N	C	Screw holder	ビスホルダ-	
3	RLCUC0004QSPZ		BE	GN	N	C	LCD	LCD	
4	CCOV-0137QS02		AQ	EQ	N	D	Operation panel upper cover(Refer to Matrix)	操作パネル上カバー	
	CCOV-0137QS03		AQ	EQ	N	D	Operation panel upper cover(Refer to Matrix)	操作パネル上カバー	
	CCOV-0137QS04		AY	FQ	N	D	Operation panel upper cover(Refer to Matrix)	操作パネル上カバー	
5	CPNLC0093QS01		AN	EQ	N	D	Key sheet(Refer to Matrix)	キーシート	
	CPNLC0093QS02		BH	HC	N	D	Key sheet(Refer to Matrix)	キーシート	
	CPNLC0093QS03		BA	FX	N	D	Key sheet(Refer to Matrix)	キーシート	
6	PLNS-0029QSZZ		AD	DD	N	C	Lens B	レンズ B	
7	PLNS-0105FCZZ		AC	DJ		B	PS key lens	電源キーレンズ	
8	JBTN-0145QSZZ		AF	DS	N	D	Key C	キー C	
9	XEBS730P08000		AC	DD		C	Screw(3x8)	ビス	
10	JBTN-0143QSZZ		AF	DS	N	D	Key A	キー A	
11	JBTN-0144QSZZ		AG	DS	N	D	Key B	キー B	
12	JBTN-0142QSZZ		AE	DS	N	D	Interrupt key	割り込みキー	
13	CBTN-0296FC05		AM	EG	N	C	10 key	テンキー	
14	CBTN-0293FC02		AN	EG		C	Power save switch	節電キー	
15	CBTN-0297FC01		AF	DS		C	CA key(Refer to Matrix)	CA キー	
	CBTN-0297FC02		AF	DS		C	CA key(Refer to Matrix)	CA キー	
16	CBTN-0146QS01		AN	EG	N	D	Start key assy	スタートキーアッセン	
17	XEBS740P08000		AA	DD		C	Screw(4x8)	ビス	
18	PFILW0036QSZZ		AD	DJ	N	C	Start key frame	スタートキー枠	
	(Unit)								
901	DUNT-1239RS11		BN	LP	N	E	Operation unit(Refer to Matrix)	操作ユニット	
	DUNT-1239RS12		BS	MJ	N	E	Operation unit(Refer to Matrix)	操作ユニット	
	DUNT-1239US13		BL	HL	N	E	Operation unit(Refer to Matrix)	操作ユニット	

### Matrix

No.4		操作パネル上カバーアッセン (Operation panel upper cover assy)		
PARTS CODE	Americas1 Europe Australia Asia Brazil SouthAfrica Namibia	Taiwan	Japan(日本)	
CCOV-0137QS02	1st Lot			
CCOV-0137QS03			1st Lot	
CCOV-0137QS04		1st Lot		

No.5		キーシート (Key sheet)		
PARTS CODE	Americas1 Europe Australia Asia Brazil SouthAfrica Namibia	Taiwan	Japan(日本)	
CPNLC0093QS01	1st Lot			
CPNLC0093QS02			1st Lot	
CPNLC0093QS03		1st Lot		

No.15		CA キー (CA key)		
PARTS CODE	Americas1 Europe Australia Asia Class B	Taiwan	Japan(日本)	
CBTN-0297FC01			1st Lot	
CBTN-0297FC02	1st Lot			

## 2 操作パネル (Operation Panel)

No.901	操作ユニット (Operation unit)		
PARTS CODE	Americas1 Europe Australia Asia Brazil SouthAfrica Namibia	Taiwan	Japan(日本)
DUNT-1239RS11	1st Lot		
DUNT-1239RS12			1st Lot
DUNT-1239US13		1st Lot	

## 2 操作パネル (Operation Panel)

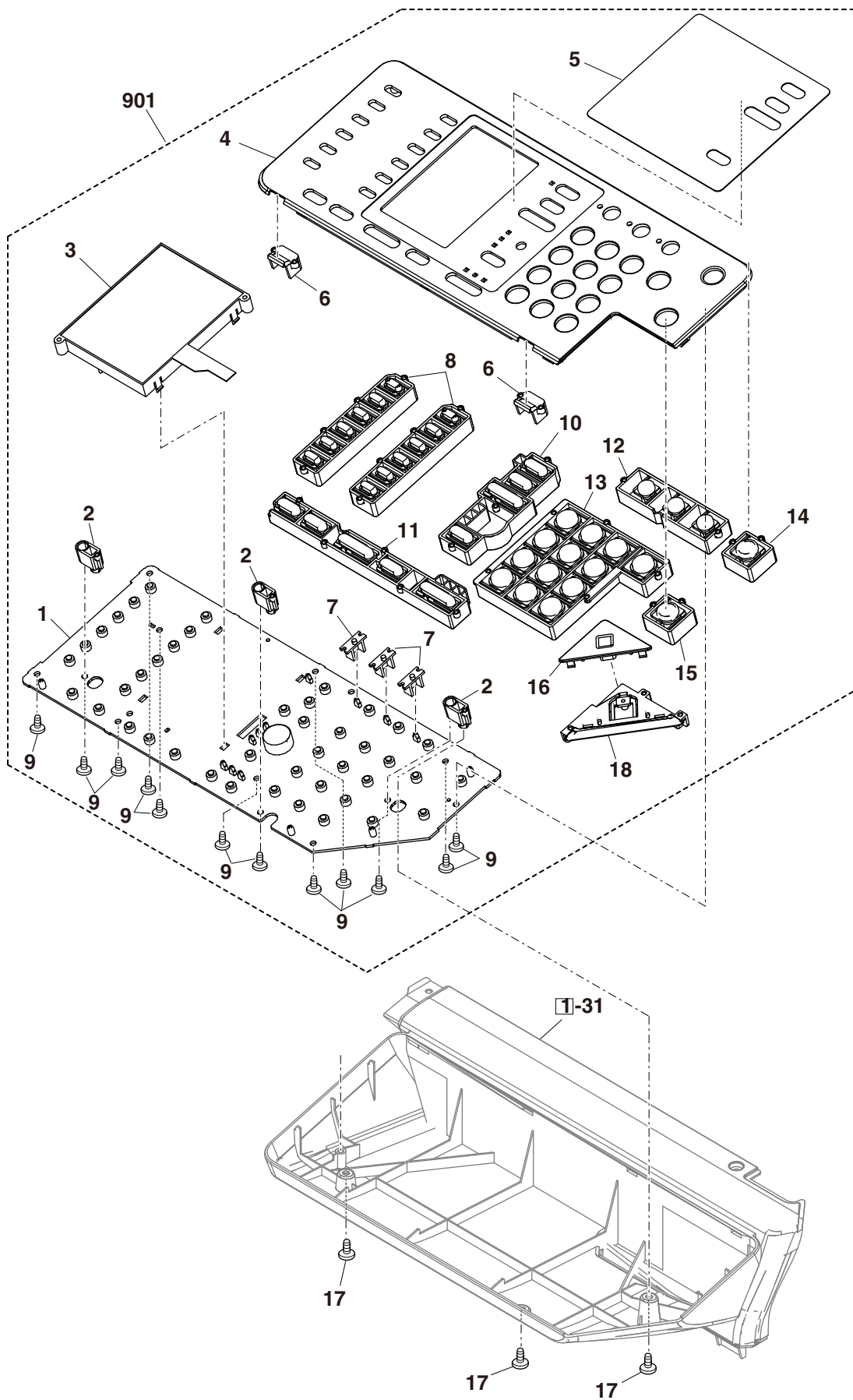

3 RSPF 外装・搬送 (Exteriors, Transport)[AR-6131N,AR-6120N,AR-RP11]

NO.	PARTS CODE	Inter-change	PRICE Ex.	RANK Ja.	NEW MARK	PART RANK	DESCRIPTION	Reason for change	Effective time
1	PGiDM2500FCB5		AT	EZ	N	C	Paper feed upper paper guide	給紙上ハ°-バ°-カ°-ト°	
2	MLEVP0932FCZZ		AC	DJ		C	Paper enter detect actuator	入紙検知アクチエ-ター	
3	MSPRD3378FCZZ		AB	DJ		C	Paper enter detect actuator return spring	入紙検知アクチエ-ター 復帰ス°リンク°	
4	LHLDZ1755FCZZ		AC	DJ		C	PS pressure holder	PS 圧接ホ-ルダ-	
5	MSPRC4039FCZZ		AC	DJ		C	PS pressure spring	PS 圧接ス°リンク°	
6	XEBS730P16000		AA	DD		C	Screw(3×16)	ビス	
7	XWHS730-05080		AA	DD		C	Washer(M3)	ワッシャ-	
8	PCOVP2290FCEZ		AX	FG	N	D	Upper cover	上加°-	
	PCOVP2290FCDZ	1	AX	FG	N	D	Upper cover	上加°-	Productivity improvement 14/Mar
9	NSFTZ2009QSPZ		AL	EB		C	Transport follower shaft	搬送従動軸	
10	NRÖLP1517FCZZ		AA	DJ		C	Transport follower roller	搬送従動ローラ-	
11	MARMP0325FCZZ		AC	DJ		C	Upper guide link arm	上ガイドリンクア-ム	
12	MSPRT3390FCZZ		AC	DJ		C	Link arm return spring	リンクア-ム復帰ス°リンク°	
13	GCAB-1361FCC1		AR	EQ	N	D	SPF rear cabinet	SPF 後ホ-ビ°	
14	MLEVP1185FCZZ		AC	DJ		C	PS front actuator	PS 前アクチエ-ター	
15	GCOV-0138QSZZ		AF	DS	N	D	F cabinet cover	F ホ-ビ° 上加°-	
16	VHPSG2A141+-1		AF	DS		B	Photo sensor(SG2A141)	フォトセンサ-	
17	VHPLG248NL1-1		AF	DS		B	Photo sensor(LG248NL1)	フォトセンサ-	
18	TLABH5695FCZZ		AH	DX		C	Cleaning cautions label [Japan( 日本 )]	清掃注意ラベル	
20	XEBS740P10000		AA	DD		C	Screw(4×10)	ビス	
21	XEBS730P08000		AC	DD		C	Screw(3×8)	ビス	
23	MSPRD4047FCZZ		AC	DJ		C	Paper feed shaft earth spring	給紙軸ア-ス°リンク°	
24	XHBS730P08000		AB	DD		C	Screw(3×8)	ビス	
25	NSFTZ3435FCZZ		AF	DS		C	Paper feed shaft	給紙軸	
26	XPSSP20-10000		AA	DD		C	Spring pin(2-10)	ス°リンク°ピ-ン	
27	NGERH2309FCZZ		AD	DJ		C	Pick up roller gear(18T)	ピ-ックアップ° ローラ°ギヤ	
28	XRESP50-06000		AA	DD		C	E type ring(E5)	E リンク°	
29	GCAB-1318FCCZ		AK	DX		D	SPF front cabinet	SPF 前ホ-ビ°	
30	NBRGM0968FCZZ		AC	DD		C	Mirror bearing N	ミラ-軸受 N	
32	QSW-M0502FCPZ		AH	DX		B	Door switch(AM51632C531)	ドアスイッチ	
33	MARMP0324FCZZ		AB	DJ		C	Lock arm	ロックア-ム	
34	MARMP0330FCZZ		AC	DJ		C	Paper lock arm	用紙ロックア-ム	
35	MARMP0339FCZZ		AC	DJ		C	Lock release arm	ロック解除ア-ム	
36	PSHEP6047FCZZ		AA	DJ		C	PS guide mylar	PS 案内マイラ-	
37	LX-WZ0469FCPZ		AA	DD		C	Washer	ワッシャ-	
38	PMLT-1652FCZZ		AC	DJ		C	Pickup damper cushion N	呼込み消音パ-ル N	
39	LHLDZ1650FCZZ		AD	DJ		C	Pickup roller holder	呼込みローラ°ホルダ-	
40	LPiNS0089FCZZ		AA	DD		C	Spring pin	ス°リンク°ピ-ン	
41	PCLC-0339FCZZ		BE	GN		A	Pickup torque limiter	呼込みトルクリミッタ-	
42	PGiDM2138FCAZ		AD	DD		C	Upper transport support paper guide	上搬送補助ハ°-バ°-カ°-ト°	
43	LHLDZ1640FCZZ		AC	DJ		C	Paper feed guide holder	給紙ガイドホルダ-	
45	NPLYZ0437FCZZ		AT	EZ		C	Paper feed pulley	給紙プ-リー	
46	NBLTH0442FCZZ		AD	DJ		B	Belt(132)	ベルト	
47	NCPL-0081FCZZ		AH	DX		B	One way coupling	ワンウェイカップリング°	
48	NRÖLR1541FCAZ		AG	DX	N	A	Paper feed separate roller	給紙分離ローラ-	
49	XHBS740P08000		AA	DD		C	Screw(4×8)	ビス	
50	PGiDM2139FCZZ		AC	DJ		D	Holder guide	ホルダ°-ガイド	
51	XRESP40-06000		AA	DD		C	E type ring(E4)	E リンク°	
52	NPLYZ0452FCZZ		AC	DJ		C	Pickup pulley(18P)	呼込みプ-リー	
54	NSFTZ2915FCZZ		AM	EG		C	Pickup shaft	呼込み軸	
	NRÖLR1542FCZZ		AH	DX		A	Pickup roller	呼込みローラ-	
55	NRÖLR1542FCAZ	1	AH	DX		A	Pick up roller	呼び込みローラ-	Productivity improvement 15/Jan
58	MLEVP0953FCZZ		AC	DJ		C	PE actuator	PE アクチエ-ター	
59	MSPRD3582FCZZ		AB	DJ		C	PE return spring	PE 復帰ス°リンク°	
60	LX-WZ0473FCZZ		AA	DD		C	Poly slider	ポリスライダ-	
501	DUNT-1246RSZZ		BK	HG	N	E	Paper feed unit	給紙ユニット	
	(Unit)								
901	DUNT-1245RSZZ		CD	UB	N	E	RSPF unit	RSPF ユニット	

③ RSPF 外装・搬送 (Exteriors, Transport)[AR-6131N,AR-6120N,AR-RP11]

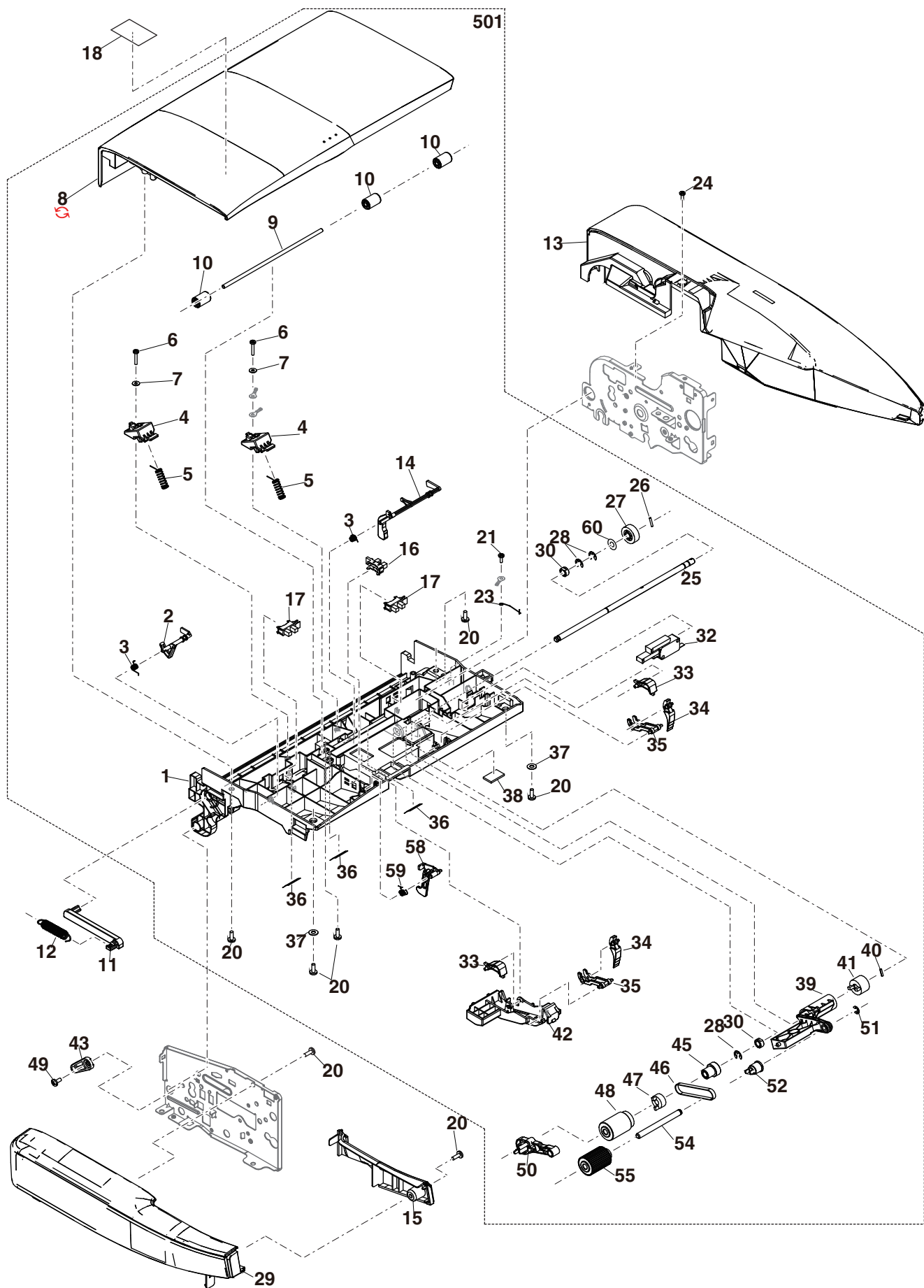



4 RSPF 給紙・原稿トレイ (Paper feed, Original tray)[AR-6131N,AR-6120N,AR-RP11]

NO.	PARTS CODE	Inter-change	PRICE RANK Ex.	PRICE RANK Ja.	NEW MARK	PART RANK	DESCRIPTION	Reason for change	Effective time
1	PGiDM2501FCCZ		AP	EQ		C	Separate paper guide	分離ペーパーガイド	
2	PCLR-0461FCZZ		AC	DJ		C	U-turn collar	Uターンコリ	
3	MSPRT4050FCZZ		AC	DJ		C	Separate pressure spring	分離圧接スプリング	
4	PSHEP6068FCZ1		AB	DD		C	Separate guide sheet F	分離ガイドシートF	
5	NSFTP3429FCZZ		AC	DJ		C	Separate fulcrum shaft	分離支点軸	
6	XEBS730P08000		AC	DD		C	Screw(3x8)	ビス	
7	PSHEP6069FCZ1		AB	DD		C	Separate guide sheet R	分離ガイドシートR	
8	PCOVP1850FCAZ		AC	DD		D	Separation roller cover	分離ローラカバー	
9	PSHEZ5462FCZ1		AD	DJ		C	Front separate sheet	前捌きシート	
10	PGiDH2535FCZZ		AL	EB		C	Transport upper paper guide	搬送上ペーパーガイド	
	PSHEZ5782FCZZ		AC	DJ		C	Rotation plate sheet N	回転板シートN	
11	PSHEZ6066FCZZ	1	AC	DJ		A	Rotation cork plate sheet	回転板コルクシート	Productivity improvement
									15/May RC
12	XHBS740P08000		AA	DD		C	Screw(4x8)	ビス	
13	XRESP40-06000		AA	DD		C	E type ring(E4)	Eリング	
15	LFiX-0040QSZZ		AC	DD	N	C	SPF torque limiter fixer	SPFトルクミッター押え	
16	MSPRC0636QSZZ		AD	DJ	N	C	SPF torque limiter spring	SPFトルクミッタースプリング	
17	LFiX-0039QSZZ		AC	DD	N	C	SPF separate coupling	SPF分離カップリング	
18	XEPS730P08X00		AA	DD		C	Screw(3x8)	ビス	
19	PMLT-1975FCZZ		AD	DJ		C	Actuator damper cushion	アクチュエーター消音ムシ	
20	NROLR1541FCAZ		AG	DX	N	A	Paper feed separate roller	給紙分離ローラ	
21	NSFTZ0196QSZZ		AE	DS	N	C	SPF separate shaft	SPF分離軸	
22	LHLDZ2081FCZZ		AD	DJ		C	Separate shaft holder R	分離軸ホルダー-R	
23	LHLDZ2080FCZZ		AC	DJ		C	Separate shaft holder F	分離軸ホルダー-F	
24	XHBS730P06000		AC	DD		C	Screw(3x6)	ビス	
25	XEBS740P10000		AA	DD		C	Screw(4x10)	ビス	
26	PBRSS0008QSZ1		AH	DX		B	Discharger brush N	除電ブラシN	
27	LSOU-0235FCB2		AZ	FQ	N	D	Original tray upper	原稿トレイ上	
28	LPLTP6485FCCZ		AG	DX		C	RSPF regulation plate F	RSPF規制板F	
29	LPLTP6486FCCZ		AF	DS		C	RSPF regulation plate R	RSPF規制板R	
30	PCOVP2291FCZZ		AC	DJ		D	Original tray fulcrum cover	原稿トレイ支点カバー	
34	MLEVP0098QSB1		AC	DD	N	C	Original detect actuator	原稿検知アクチュエーター	
35	VHPSG2A141+-1		AF	DS		B	Photo sensor(SG2A141)	フォトセンサー	
36	XHBS740P12000		AB	DD		C	Screw(4x12)	ビス	
38	LPLTP0321QSA1		AE	DS	N	C	Width detect sensor fixing plate	幅検知センサー取付板	
39	NGERP0168QSZZ		AD	DJ		C	Width detect pinion gear(36T)	幅検知ピニオンギア	
40	MSPRP0315QSZZ		AD	DJ		C	Regulation plate spring	規制板スプリング	
41	NGERR0169QSZZ		AE	DS		C	SPF VR PWB LF rack	SPF VR基板LFラック	
43	LSOU-0077QSZZ		AS	EZ	N	D	Original tray lower	原稿トレイ下	
44	LHLDZ1640FCZZ		AC	DJ		C	Paper feed guide holder	給紙ガイドホルダー	
45	XEBS730P08000		AC	DD		C	Screw(3x8)	ビス	
47	CPWBF1594FCE3		AS	EQ		E	SPF VR PWB LF	SPF VR基板LF	
48	MARMP0054QSZ1		AD	DJ		C	Paper fixing arm	用紙押えアーム	
	(Unit)								
901	CSOU-0077RS51		BF	GN	N	E	Original tray unit	原稿トレイユニット	

4 RSPF 給紙・原稿トレイ (Paper feed, Original tray)[AR-6131N,AR-6120N,AR-RP11]

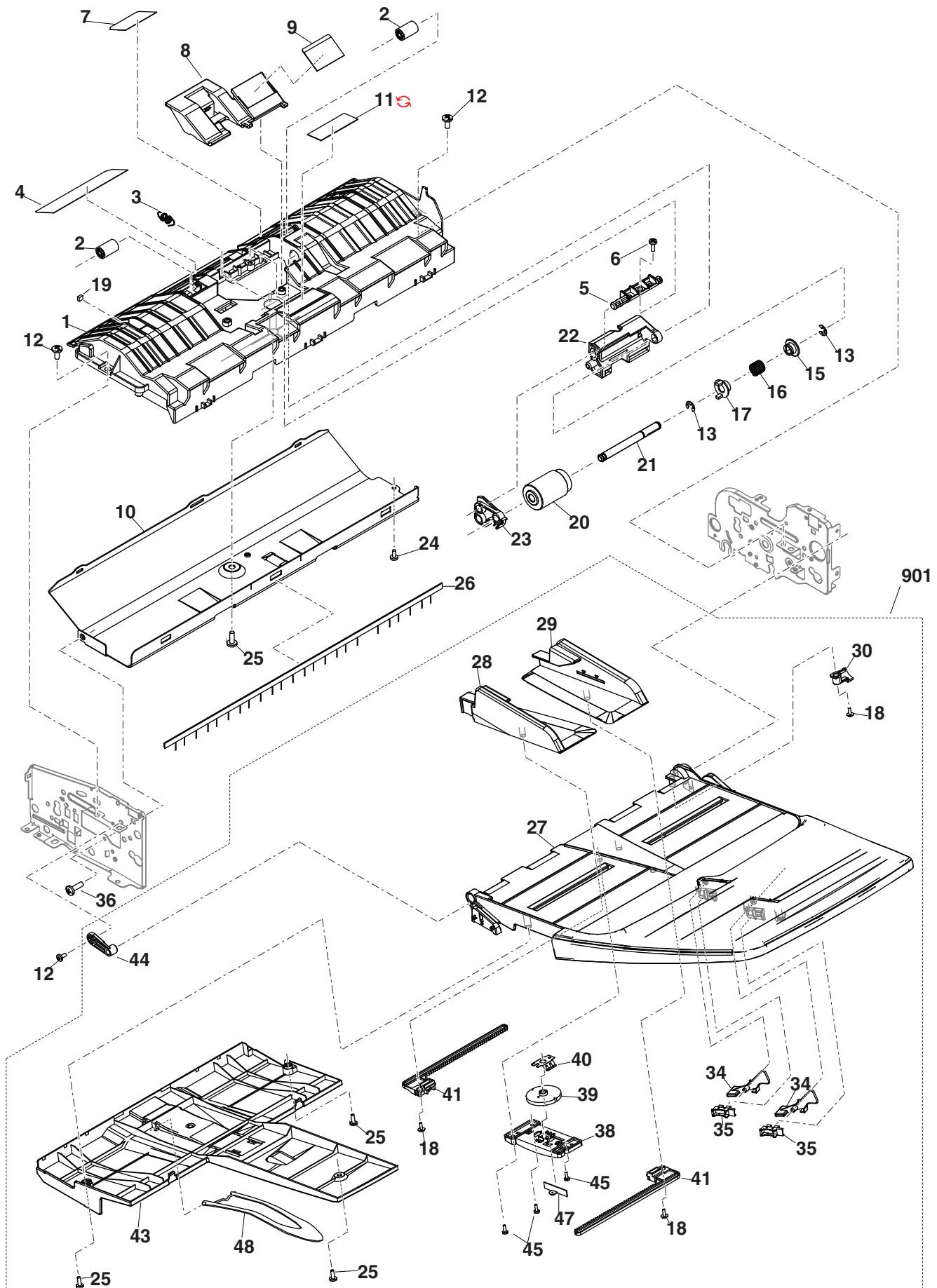

5 RSPF 搬送部 (Paper transfer section)[AR-6131N,AR-6120N,AR-RP11]

NO.	PARTS CODE	Inter-change	PRICE RANK		NEW MARK	PART RANK	DESCRIPTION	Reason for change	Effective time
			Ex.	Ja.					
1	PGiDM0265QSZZ		AT	EZ	N	C	Transport paper guide	搬送部ガイド	
2	PSHEP6047FCZZ		AA	DJ		C	PS guide mylar	PS 案内マイラー	
3	MSPRC3353FCZZ		AB	DJ		C	Read plate pressure spring	読取板圧接スプリング	
4	LPLTP7865FCZ1		AD	DJ	N	C	Sensor fixing plate	センサー取付板	
	LPLTP7865FCZ2	3	AD	DJ	N	C	Sensor fixing plate	センサー取付板	Productivity improvement 15/Mar
5	VHPLG248NL1-1		AF	DS		B	Photo sensor(LG248NL1)	フォトセンサー	
6	XEBS740P10000		AA	DD		C	Screw(4x10)	ビス	
7	MLEVP1163FCZ1		AC	DD		C	Read front actuator	読取前アクチュエーター	
8	MSPRD4045FCZZ		AC	DJ		C	Read front actuator spring	読取前アクチュエーター スプリング	
9	PMLT-1975FCZZ		AD	DJ		C	Actuator damper cushion	アクチュエーター消音マット	
10	LPLTM7997FCZZ		AK	DX		C	Reading plate	読取板	
11	PSHEP6193FCZZ		AD	DJ		C	White sheet	白マイラー	
12	PSHEP5163FCZZ		AA	DJ		C	Paper feed rear mylar 2	給紙後マイラー-2	
13	PGiDM0266QSZZ		AN	EG	N	C	Reverse gate	反転ゲート	
14	XHBS730P08000		AB	DD		C	Screw(3x8)	ビス	
15	XEBS740P10000		AA	DD		C	Screw(4x10)	ビス	
501	CPLTM7997DS51		AT	EZ		E	Reading plate unit	読取板ユニット	

5 RSPF 搬送部 (Paper transfer section)[AR-6131N,AR-6120N,AR-RP11]

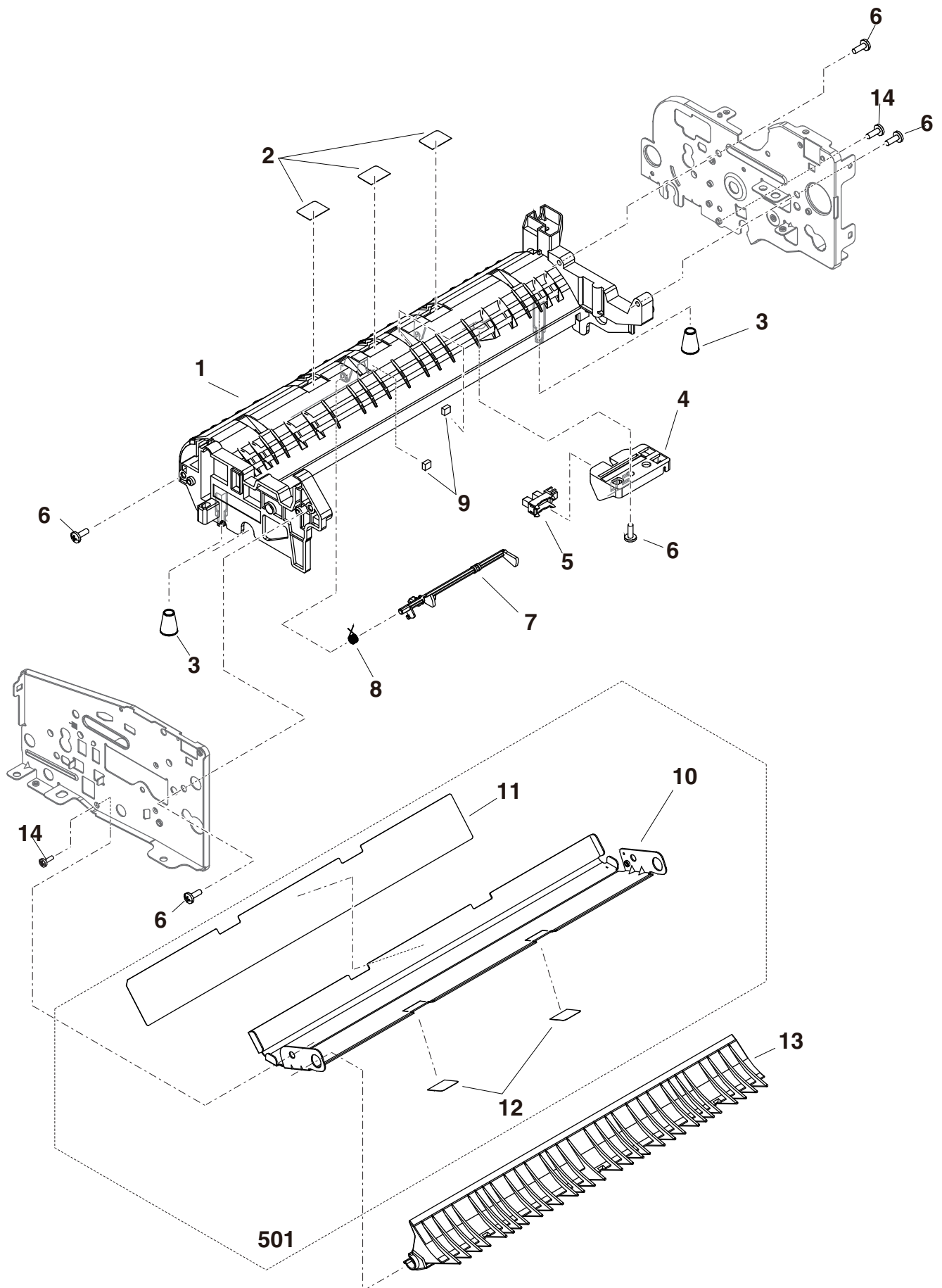

6 RSPF へ-ストレイ (Base tray)[AR-6131N,AR-6120N,AR-RP11]

NO.	PARTS CODE	Inter-change	PRICE Ex.	RANK Ja.	NEW MARK	PART RANK	DESCRIPTION		Reason for change	Effective time
1	LSOU-0076QSAZ		BH	GX	N	D	Base tray	へ-ストレイ		
1	LSOU-0076QSZZ	1	BH	GX	N	D	Base tray	へ-ストレイ	Productivity improvement	14/Mar
2	PMLT-1971FCZZ		AA	DJ		C	Gate damper cushion	ゲ-ト消音モルト		
3	MSPRC3413FCZZ		AB	DJ		C	Open/close look spring	開閉ロックスプリング		
4	LHLDZ2077FCZZ		AC	DJ		C	Read front follower holder	読取前従動ホルダ		
5	NSFTP3428FCZZ		AC	DJ		C	Read front follower shaft	読取前従動軸		
6	NROLP1517FCZZ		AA	DJ		C	Transport follower roller	搬送従動ローラ		
7	MSPRP0123QSZZ		AD	DJ		C	Transport follower spring	搬送従動スプリング		
8	XEBS730P08000		AC	DD		C	Screw(3x8)	ビス		
9	XHBS730P18000		AA	DD		C	Screw(3x18)	ビス		
10	PSHEZ0925QSZZ	-	AC	DD	N	C	RSPF sheet	RSPF マイラー	Improve performance	15/Feb
11	NSFTZ0009QSPZ		AL	EB		C	Transport follower shaft	搬送従動軸		
12	PSHEP6265FCZZ		AA	DJ		C	Reading front damper sheet	読取前消音シート		
13	PSHEZ5372FCZ1		AD	DJ		C	Read front sheet	読取前シート		
14	PSHEP6192FCZZ		AD	DJ		C	Reading rear sheet	読取後シート		
15	LPLTM7998FCZZ		AE	DJ		C	Solenoid fixing plate	ソレノイド取付板		
16	RPLU-0015QSP1		AR	EQ		B	Reverse solenoid	反転ソレノイド		
17	XBBS730P04000		AA	DD		C	Screw(3x4)	ビス		
18	XEBS740P10000		AA	DD		C	Screw(4x10)	ビス		
20	MHNG-0022QSBZ		BB	GD		C	SPF hinge R	SPF ヒンジ R		
21	XEBS740P14000		AB	DD		C	Screw(4x14)	ビス		
22	XWVS740-05000		AA	DD		C	Washer(M4)	菊ワッシャー		
23	CPWBN1958FCE4		BB	GD	N	E	RSPF driver PWB	RSPF ドライバ基板		
25	NSFTZ3496FCZZ		AR	EQ		C	Pressure release shaft	圧力解除軸		
26	MLEVF0093QSZZ		AE	DJ		C	Pressure release lever	圧解レバー		
27	LX-BZ3006SCPM		AA	DD		C	Screw	ビス		
28	NBRGM0968FCZZ		AC	DD		C	Mirror bearing N	ミラー軸受 N		
29	XRESP50-06000		AA	DD		C	E type ring(E5)	E リング		
30	LHLDZ2142FCZZ		AC	DJ		C	Pressure release hodler	圧解ホルダ		
31	LPI NS0134FCZZ		AB	DD		C	Pin(φ2-12)	平行ピン		
32	MSPRD4125FCZZ		AD	DJ		C	Delivery follower spring	排紙従動スプリング		
34	PMLT-2089FCZZ		AA	DD		C	Reversal Act damper cushion	反転 Act 消音モルト		
35	PGSK-0077FCZZ		AE	DS		C	Gasket FL	ガスケット FL		
36	PMLT-1935FCZZ		AA	DJ		C	Pressure release damper molt	圧解消音モルト		
37	XHBS730P06000		AC	DD		C	Screw(3x6)	ビス		
39	NSFTZ3495FCZZ		AC	DJ		C	Delivery follower shaft	排紙従動軸		
40	NROLP0011QSZZ		AD	DJ		C	Delivery follower roller	排紙従動ローラ		
41	PSHEZ5374FCZ1		AC	DJ		C	OC position sheet	OC 位置決めシート		
42	LX-BZ0586FCZZ		AA	DD		C	Screw(4x6)	ビス		
43	VHPLG248NL1-1		AF	DS		B	Photo sensor(LG248NL1)	フォトセンサー		
44	CCL EZ0027RS51		AM	EG	N	E	SPF glass cleaner	SPF ガラスクリーナー		
45	PSHEZ6631FCZ1		AR	EQ	N	D	OC mat	OC マット		
46	PSPO-0032QSZZ		AC	DJ		C	Delivery sponge	蹴り出しスポンジ		
47	PCOVP2286FCZZ		AG	DX		D	Follower roller cover	従動ローラカバー		
49	MLEVP1184FCZ1		AC	DD		C	Reverse front actuator	反転前アクチュエーター		
50	MSPRD4045FCZZ		AC	DJ		C	Read front actuator spring	読取前アクチュエーター スプリング		
51	PSHEZ0610QSZZ		AA	DJ		C	Follower spring sheet	従動スプリングシート		
52	MSPRC4124FCZZ		AD	DJ		C	Transport follower earth spring	搬送従動 アーススプリング		
54	MHNG-0021QSBZ		BB	GD		C	SPF hinge L	SPF ヒンジ L		
55	LSOU-0050QSEZ		AD	DJ		C	Delivery extension tray	排紙延長トレイ		
56	XEBS730P10000		AC	DD		C	Screw(3x10)	ビス		
57	PSPO-0022QSZZ		AB	DJ		C	Pressure release damper sponge	圧解消音スポンジ		
501	CSOU-0076RS51		BR	LP	N	E	SPF base tray unit	SPF へ-ストレイユニット		

6 RSPF ㄸ-ㄸㄸㄸ (Base tray)[AR-6131N,AR-6120N,AR-RP11]

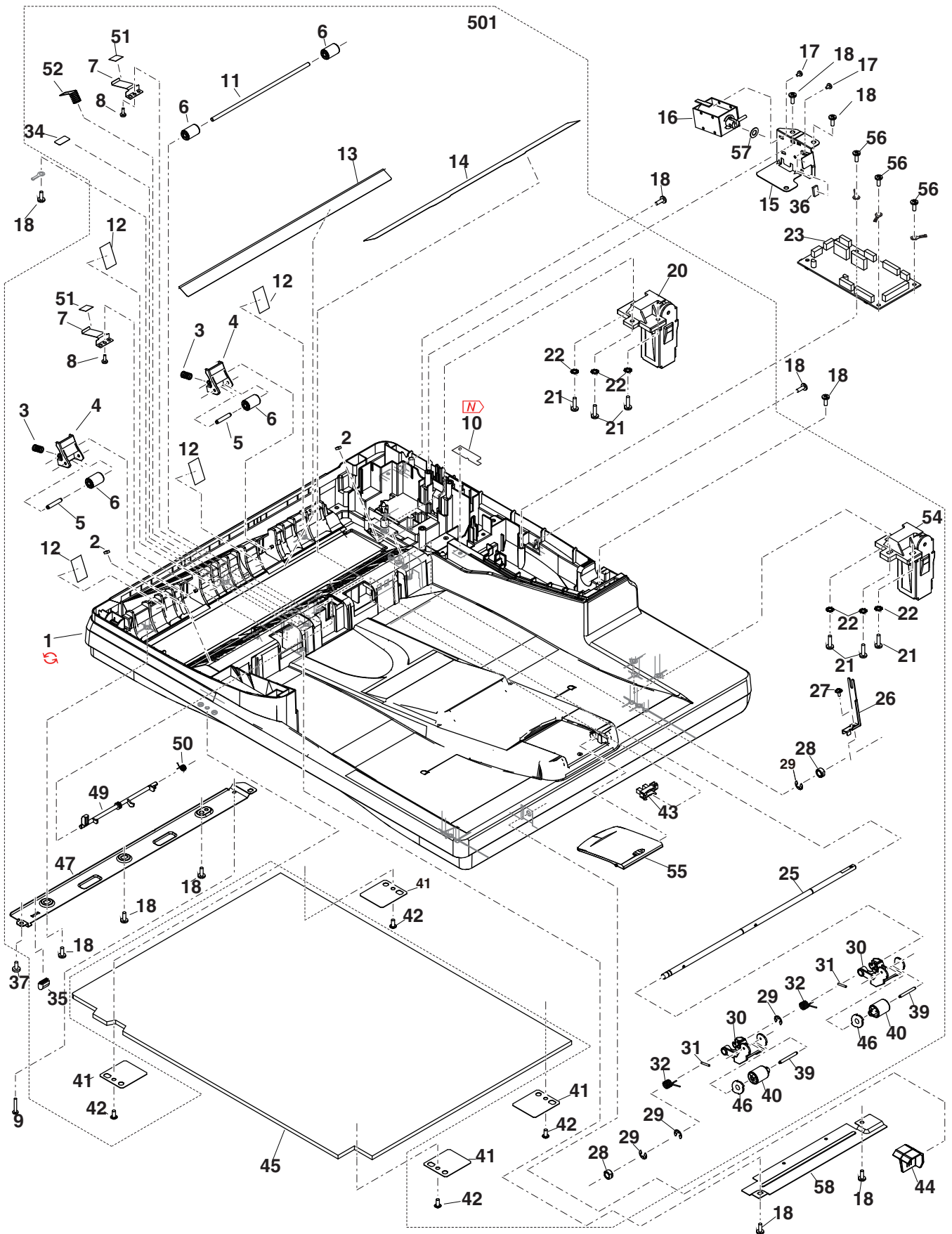



7 RSPF 駆動部 (Drive section)[AR-6131N,AR-6120N,AR-RP11]

NO.	PARTS CODE	Inter-change	PRICE RANK Ex.	RANK Ja.	NEW MARK	PART RANK	DESCRIPTION	Reason for change	Effective time
1	NBLTH0561FCZZ		BA	FX		B	Belt(40S2M236)		
2	NBRGM0501FCZZ		AB	DJ		C	Metal bearing		
3	XRESP50-06000		AA	DD		C	E type ring(E5)		
4	NSFTZ3437FCZZ		AD	DJ		C	Transport shaft		
5	NPLYZ0525FCZZ		AH	DX		C	Pulley(37P)(1WAY)		
6	LX-WZ0473FCZZ		AA	DD		C	Poly slider		
7	NGERH2034FCZ1		AD	DJ		C	Gear 37T/64P		
8	XPSSP20-10000		AA	DD		C	Spring pin(2-10)		
	LX-WZ5002BCZZ		AA	DD		C	Poly slider(M6)		
9	LX-WZ0448FCZZ	3	AB	DD		C	Poly slider(6×12×0.5)	Improve performance	14/Nov
	LX-WZ0448FCZZ	-	AB	DD		C	Poly slider(6×12×0.5)	Improve performance	14/Nov
11	XRESP40-06000		AA	DD		C	E type ring(E4)		
12	PCLR-0520FCZZ		AB	DJ		C	Tension collar		
13	NGERH2308FCZZ		AD	DJ		C	Paper feed gear(54P/18T)		
14	NBLTH0520FCZZ		AE	DS		B	Belt(40S2M212BLT)		
15	CFRM-1478FC01		AH	DX		D	Drive frame		
16	LHLDZ2073FCZZ		AE	DJ		C	Transport motor tension holder		
17	XWHS760-08115		AA	DD		C	Washer(φ6-11)		
18	RMOTS0986FCPZ		BD	GN		B	RSPF transport motor		
22	XWHS730-05080		AA	DD		C	Washer(M3)		
23	CPLTM0783QS01		AF	DS	N	C	Paper feed tension plate		
24	MSPRT0635QSZZ		AD	DD	N	C	Paper feed tension spring		
25	XHBS730P06000		AC	DD		C	Screw(3×6)		
27	XEBS740P10000		AA	DD		C	Screw(4×10)		
28	PCLC-0371FCZZ		AP	EQ		B	SPF paper feeding clutch		
34	MSPRT4052FCZZ		AC	DJ		C	Transport motor tension spring		
39	MSPRC4040FCZZ		AC	DJ		C	Brake spring		
41	PCLC-0027QSZ1		AP	EQ		B	Reversal clutch T		
46	NGERH0433QSZZ		AD	DD	N	C	Gear(32P)		
49	NGERH0022QSZZ		AC	DJ		C	33T gear		
50	CPLTM7867FC01		AE	DJ		C	Tension plate R		
51	PCLR-0520FCZZ		AB	DJ		C	Tension collar		
55	LHLDZ2078FCZZ		AC	DJ		C	Stopper holder		
56	PTME-0030QSZZ		AC	DJ		C	Open/close lock pawl		
57	MSPRC3356FCZZ		AA	DJ		C	Lock spring		
62	NGERH2037FCZZ		AC	DJ		C	67T gear		
66	NGERH1620FCZZ		AC	DJ		C	32T gear		
67	NGERH0425QSZZ		AD	DD	N	C	Paper feed coupling pulley(37P)		
69	CFRM-1477FC01		AL	EB		D	R frame		
70	MSPRT4051FCZZ		AC	DJ		C	Tension spring		
72	LPLTP0131QSZ1		AD	DJ	N	C	Book sensor fixing plate		
74	NR0LR1891FCZ1		AV	FG	N	C	PS roller		
75	NR0LR1813FCZ1		AM	EG		C	Read front roller		
76	NR0LR1892FCZ1		AU	EZ		C	Reading rear roller		
77	NR0LR0246QSZZ		AS	EQ	N	A	RSPF delivery roller		
78	LFRM-1476FCZZ		AG	DX		D	F frame		
82	NBRGC0017QSZZ		AC	DJ		C	Bearing(B-F6-10)		
83	NPLYZ0523FCZZ		AD	DJ		C	JAM release pulley		
86	MSPRC0153QSZZ		AB	DJ		C	Book sensor spring		
87	XBBS730P04000		AA	DD		C	Screw(3×4)		
88	MLEVP0095QSZZ		AD	DJ		C	Book sensor actuator		
89	VHPSG2A141+-1		AF	DS		B	Photo sensor(SG2A141)		
90	XHBS740P08000		AA	DD		C	Screw(4×8)		
91	LHLDZ2078FCZZ		AC	DJ		C	Stopper holder		
92	MSPRC3356FCZZ		AA	DJ		C	Lock spring		
93	PTME-0030QSZZ		AC	DJ		C	Open/close lock pawl		

7 RSPF 駆動部 (Drive section)[AR-6131N,AR-6120N,AR-RP11]

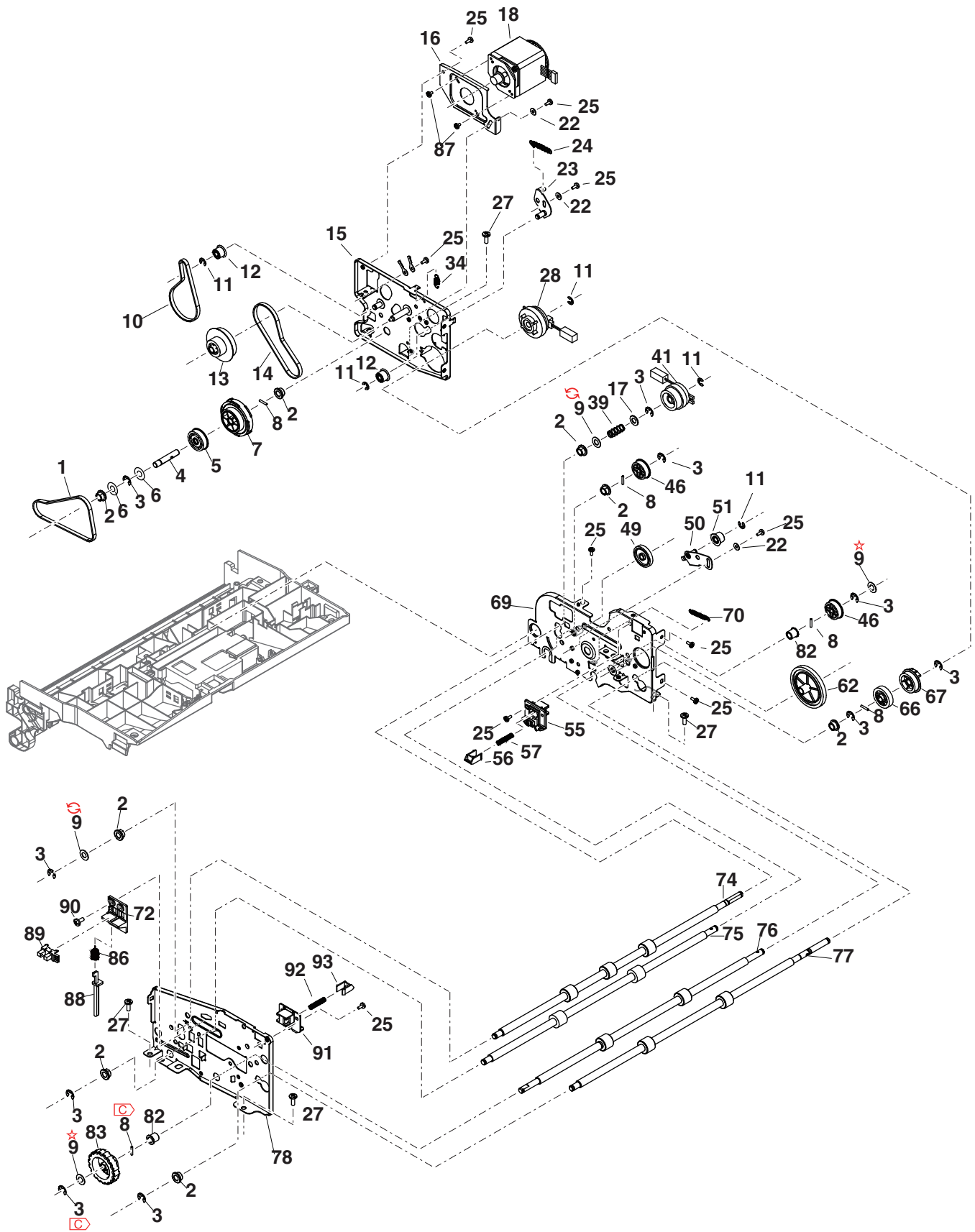



## 8 スキャナユニット 1(Scanner Unit 1)

NO.	PARTS CODE	Inter-change	PRICE RANK		NEW MARK	PART RANK	DESCRIPTION	Reason for change	Effective time
			Ex.	Ja.					
1	XEBS740P10000		AA	DD			Screw(4×10)	ビス	
2	PMLT-1896FCZZ		AB	DJ		C	Rail molt	レールモルト	
3	PSHEZ5768FCZZ		AA	DJ		C	Screw protect sheet	ビス保護シート	
4	PMLT-1791FCZZ		AA	DJ		C	T glass lower molt	Tガラス下モルト	
5	PGUMS0283FCZZ		AA	DJ		C	Table glass gum	テーブルガラスゴム	
6	VHPSG2A141+-1		AF	DS		B	Photo sensor(SG2A141)	フォトセンサー	
7	LPLTM0817QSZZ		AD	DJ	N	C	MHPS sensor fixing plate	MHPS センサ-取付板	
8	XHBS730P06000		AC	DD		C	Screw(3×6)	ビス	
	PSHEZ0875QSZZ		AF	DS	N	C	OPE FFC fixing sheet	OPE FFC 取付マフ-	
9	PSHEZ0875QSZ1	1	AF	DS	N	C	OPE FFC fixing sheet	OPE FFC 取付マフ-	Productivity improvement 14/Oct RC
10	LPLTM8624FCZZ		AF	DS		C	Hinge guide fixing plate L	ヒンジガイド固定板 L	
11	PTPE-0090QSZZ		AC	DD	N	C	OPE harness fixing tape	OPE ハ-ネ固定テープ	
12	CLNS-0017RS55		BM	HR	N	E	Lens unit	レンズユニット	
13	PCASZ0022QSZZ		AN	EG	N	C	Dark box	暗箱	
14	PSHEZ0854QSZZ		AC	DD	N	C	R side harness protect sheet	R側ハ-ネ保護マフ-	
15	PSHEZ0874QSZZ		AG	DS	N	C	MHPS sensor harness protect sheet	MHPSセンサーハ-ネ保護マフ-	
16	PTPE-0092QSZZ		AB	DD	N	C	CL FFC fixing tape	CL FFC 固定テープ	
	LPLTM8623FCZZ		AF	DS		C	Hinge guide fixing plate R	ヒンジガイド固定板 R	
17	LPLTM8623FCZ2	1	AF	DS		C	Hinge guide fixing plate R	ヒンジガイド固定板 R	Commonization 14/Oct RC
18	LPLTP0828QSZZ		AE	DJ	N	C	Interface harness guide [AR-6131N,AR-6131N,AR-6120N,AR-RP11]	中継ハ-ネガイド	
19	XHBS730P06KS0		AC	DD		C	Screw(3×6KS)	ビス	
20	PSHEP6213FCZZ		AC	DJ		C	Scanner right sheet	スキャナ右マフ-	
21	PTPE-0050QSZZ		AA	DJ		C	Core fixing tape	コア固定テープ	
22	PSHEZ0857QSZZ		AC	DD	N	C	OPE FFC protect sheet	OPE FFC 保護マフ-	
23	PGUMS0336FCZZ		AB	DJ		C	Table glass gum	テーブルガラスゴム	
24	LHLDZ0275QSZZ		AC	DD	N	C	CL lead holder	CLリードホルダ-	
25	PMLT-1958FCZZ		AC	DD	N	C	Optical cushion B	光学モルト B	
26	PMLT-1959FCZZ		AC	DD	N	C	Optical cushion C	光学モルト C	
27	PTPE-0095QSZZ		AD	DJ	N	C	FFC fixing tape	FFC 固定テープ	
	(Unit)								
901	DUNT-1224RSZZ		BZ	TR	N	E	Optical unit(Refer to Matrix)	光学ユニット	
	DUNT-1224US11		CF	UK	N	E	Optical unit(Refer to Matrix)	光学ユニット	

### Matrix

No.901	光学ユニット (Optical unit)						
PARTS CODE	Americas1	Europe	Australia	Asia	Brazil	SouthAfrica Namibia Japan(日本)	Taiwan
DUNT-1224RSZZ	1st Lot						
DUNT-1224US11	1st Lot						

8 スキャナユニット 1(Scanner Unit 1)

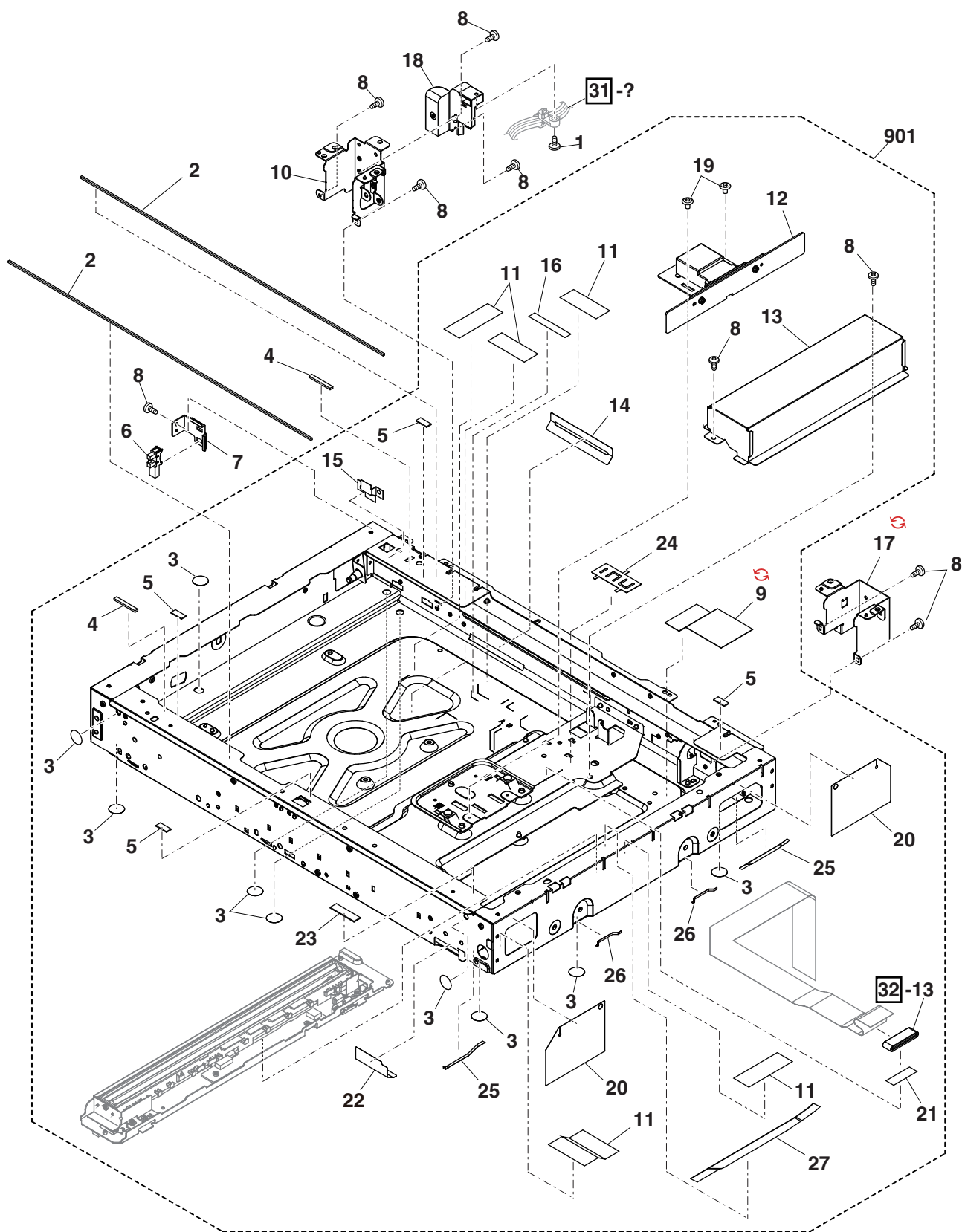

9 スキャナユニット 2(Scanner Unit 2)

NO.	PARTS CODE	Inter-change	PRICE RANK		NEW MARK	PART RANK	DESCRIPTION	Reason for change	Effective time	
			Ex.	Ja.						
1	PWiR-0191FCSZ		AN	EQ		C	MB wire R	MBワイヤ-R		
2	NPLYZ0016QSZZ		AF	DS		C	Constant pulley	定ア-リー		
3	NPLYZ0006QSZ1		AD	DJ		C	L pulley	Lア-リー		
4	XRESP40-05000		AA	DD		C	E type ring(E4)	Eリング		
5	LX-BZ0004QSPZ		AB	DD		C	Red screw(3x6)	赤ビス		
6	XHBS730P06000		AC	DD		C	Screw(3x6)	ビス		
7	RMOTS0090QSPZ		BB	GD	N	B	SCAN motor	SCAN モーター		
8	CPLTM7978FC01		AF	DS		B	Mirror motor fixing plate	ミラーモーター取付板		
9	MSPRT3388FCZZ		AC	DJ		C	Mirror motor spring	ミラーモータースプリング		
10	NGERH1647FCZZ		AE	DJ		C	Mirror motor idle gear	ミラーモーターアイドルギア		
11	NBLTH0440FCZZ		AS	EQ		C	Winder drive belt	巻取り駆動ベルト		
12	LX-WZ0119FCP1		AC	DD		C	Washer	ワッシャー		
13	XRESP70-08000		AA	DD		C	E type ring(E7)	Eリング		
14	NPLYZ0062QSZZ		AQ	EQ	N	C	Winder drive shaft pulley	巻取り駆動軸ア-リー		
15	XPSSJ30-12000		AB	DD		C	Spring pin(φ3-12)	スプリングピン		
16	NPLYZ0506FCZZ		AL	EB		C	Winder pulley	巻取りア-リー		
17	NSFTZ0192QSZZ		AP	EQ	N	C	Winder drive shaft	巻取り駆動軸		
18	LX-BZ2106ACZZ		AB	DD		C	Screw(2x4)	ビス		
19	LX-BZ0049FCPZ		AB	DD		C	Screw(4x6)	ビス		
20	NBRGY0466FCZ1		AK	DX		B	Bearing(φ8-16)	軸受		
20	NBRGP0012QSZZ	-	AC	DJ		C	Winder bearing R	巻取り軸受 R	Parts code correction	1st lot
21	PWiR-0192FCSZ		AN	EQ		C	MB wire F	MBワイヤ-F		
22	LRALM0316FCZ1		AN	EQ	N	C	MB-B rail R	MB-B レール R		
23	LRALM0226FCZ2		AN	EQ	N	C	MB-B rail F	MB-B レール F		
24	CHLDZ1446FC35		BB	GD	N	E	2nd,3rd Mirror unit	第 2,3 ミラーユニット		
25	PGiDM1890FCZ1		AC	DJ		C	CL guide	CLガイド		
26	XRESP50-06000		AA	DD		C	E type ring(E5)	Eリング		
27	NBRGP0011QSZZ	-	AC	DJ		C	Winder bearing F	巻取り軸受 F	Parts code correction	1st lot
28	PSHEZ0448QSZZ		AA	DJ		C	Optical bottom sheet	光学底マイラー	Missing parts code	15/Jan RC
29	PSHEZ0900QSZZ		AC	DD		C	Optical sheet A	光学マイラー A	Missing parts code	15/Jan RC
30	PSHEZ0901QSZZ		AC	DD		C	Optical sheet B	光学マイラー B	Missing parts code	15/Jan RC
31	PSHEZ0631QSZZ	-	AA	DJ		C	Optical sheet	光学マイラー	Improve performance	15/Jan RC

9 スキャナユニット 2(Scanner Unit 2)

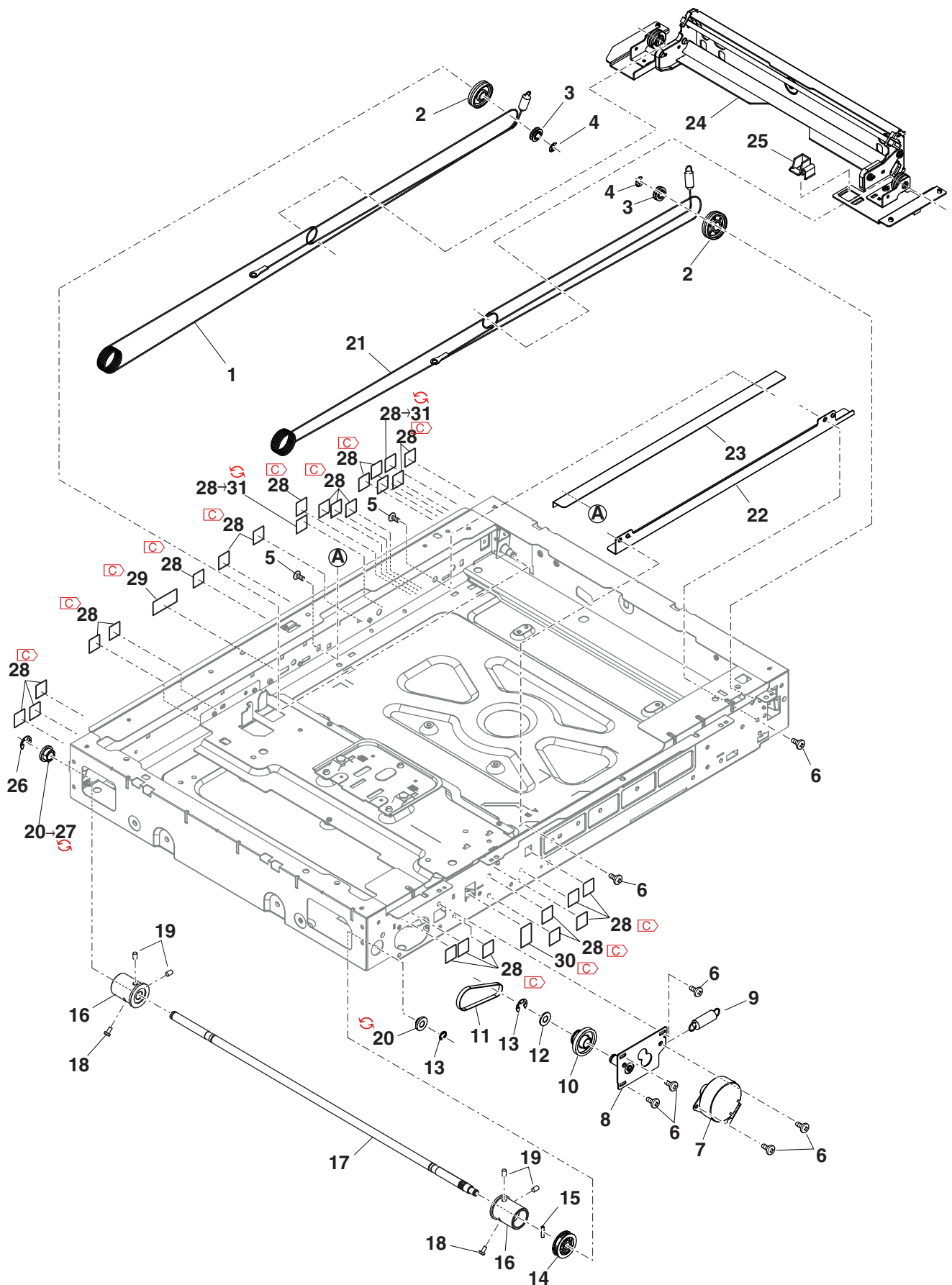

# 10 ランプユニット (Lamp unit)

NO.	PARTS CODE	Inter-change	PRICE RANK		NEW MARK	PART RANK	DESCRIPTION	Reason for change	Effective time
			Ex.	Ja.					
1	PGiDM0252QSZZ		AK	DX	N	C	LED PWB guide	LED 基板ガイド	
2	CPWBL0295QSE1		AS	EZ	N	E	LED PWB unit	LED 基板ユニット	
3	LPLTM0838QSZZ		AD	DJ	N	C	LED heat sink R	LED 放熱板 R	
4	PLGPZ0002QSZZ		AQ	EQ	N	C	Waveguide stick	導光棒	
5	XEBS730P08000		AC	DD		C	Screw(3x8)	ビス	
6	XHBS730P06000		AC	DD		C	Screw(3x6)	ビス	
7	PMiR-0164FCZ1		AM	EG	N	B	1st mirror	第1ミラー	
8	CPWBN0307QSE1		AX	FQ	N	E	LED driver PWB	LEDドライバ基板	
9	LFiX-0673FCZZ		AC	DJ		C	CL lead harness fixture	CLリードホルダ挿挿え	
10	LPLTM0772QSZZ		AQ	EQ	N	C	Lamp base	ランプベース	
11	PSHEZ0849QSZZ		AC	DD	N	C	Reflection sheet	反射シート	
12	PSHEZ0835QSZZ		AG	DS	N	C	Thermal sheet	放熱シート	
13	LPLTM0771QSZZ		AD	DJ	N	C	LED heat sink	LED 放熱板	
14	PMLT-1614FCZZ		AA	DJ		C	Rail cushion	レールクッション	
15	MSLiP0166FCZZ		AE	DJ		C	Slider	滑り材	
16	PCUSS0033QSZZ		AC	DJ		C	Mirror cushion N	ミラークッション N	
17	MSPRP4030FCZZ		AE	DJ		C	Mirror spring LED	ミラースプリング LED	
18	XBBS740P06000		AA	DD		C	Screw(4x6)	ビス	
19	LHLDZ1505FCZZ		AC	DJ		C	Wire holder	ワイヤホルダー	
20	XBBS830P06000		AA	DD		C	Screw(3x6)	ビス	
	(Unit)								
901	DUNT-1225RSZZ		BF	GN	N	E	Lamp unit(Refer to Matrix)	ランプユニット	
	DUNT-1225US13		BP	LP	N	E	Lamp unit(Refer to Matrix)	ランプユニット	

## Matrix

No.901	ランプユニット (Lamp unit)	
PARTS CODE	Americas1 Europe Australia Asia Brazil South Africa Namibia Japan(日本)	Taiwan
DUNT-1225RSZZ	1st Lot	
DUNT-1225US13		1st Lot

10 ランプユニット (Lamp unit)

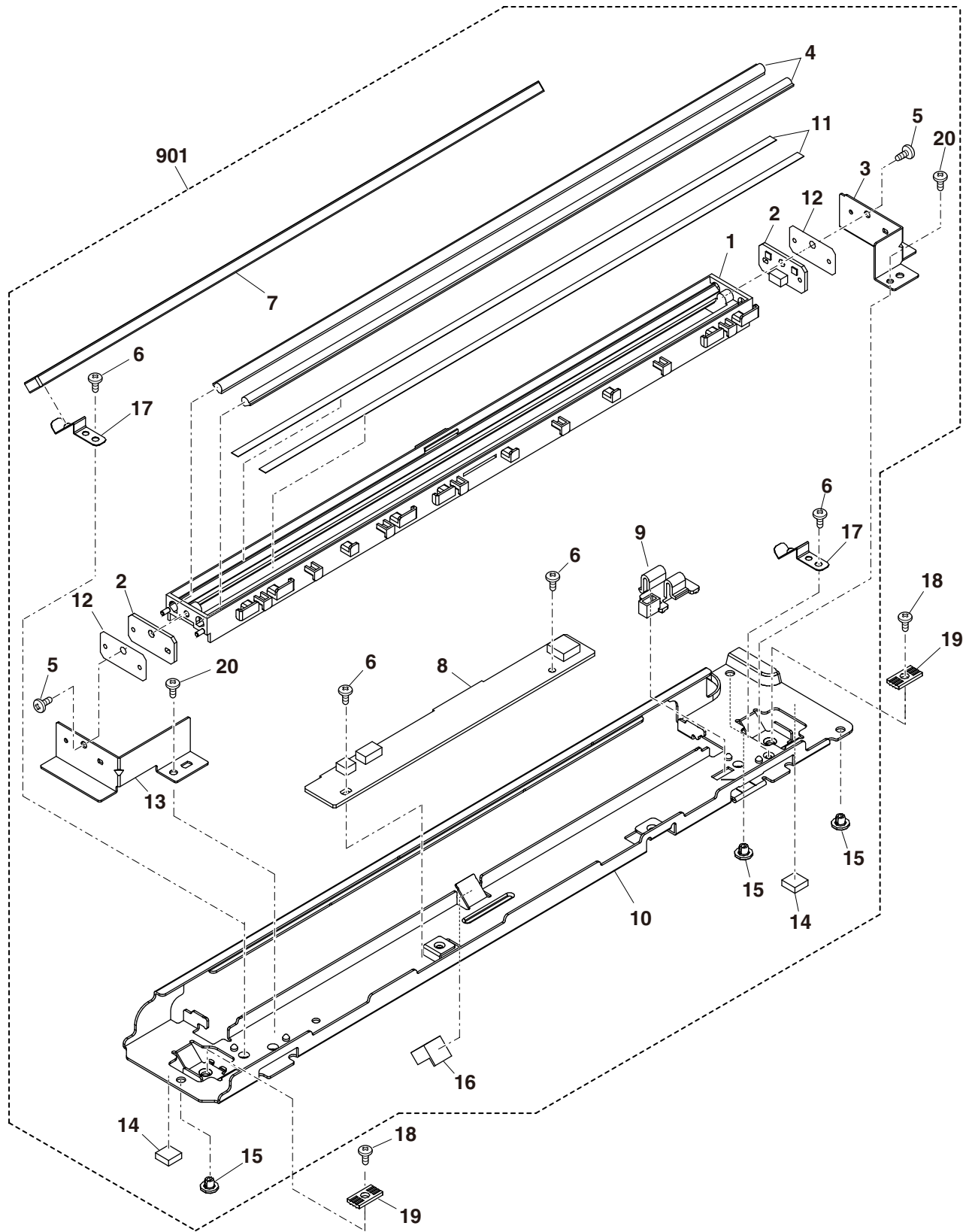

11 プロセスユニット (Process unit)

[AR-6031N,AR-6031NR,AR-6131N,AR-X311N,AR-6026N,AR-6026NR]

NO.	PARTS CODE	Inter-change	PRICE Ex.	RANK Ja.	NEW MARK	PART RANK	DESCRIPTION	Reason for change	Effective time
1	CFRM-0154QS06		AT	EZ		C	Process frame assy	ﾌﾟﾛｽﾞﾌﾚｰﾑｱｯｾﾝ	
2	PMLT-0251QSZZ		AD	DJ		A	Blade side cushion	ﾌﾞﾚｰﾄﾞｻｲﾄﾞﾓﾙﾄ	
	PMLT-0252QSZZ		AC	DD		C	Seal cushion F	密封ﾓﾙﾄF	
3	PMLT-0281QSZZ	3	AD	DD	N	C	Toner seal cushion F	ﾄﾅｰ密封ﾓﾙﾄF	Improve performance
4	CCLEZ0011QS32		BD	GN		A	Cleaning blade	ｸﾘｰﾆﾝｸﾞﾌﾞﾚｰﾄﾞ	15/Jan
5	XEBS730P10000		AC	DD		C	Screw(3×10)	ﾋﾞｽ	
6	PMLT-0254QSZZ		AF	DS		A	Drum red cushion F	ﾄﾞﾗﾑ赤ﾓﾙﾄF	
7	PMLT-0255QSZZ		AF	DS		A	Drum red cushion R	ﾄﾞﾗﾑ赤ﾓﾙﾄR	
8	NCPL-0003QSZ1		AC	DJ		C	Screw coupling	ｽｸﾚｰｸｯﾌﾟﾘﾝｸﾞ	
9	NBRGP0299FCPZ		AD	DJ		C	CL bearing	CL 軸受	
10	NSRW-0009QSZZ		AK	DX		C	Waste toner transport screw	廃ﾄﾅｰ搬送ｽｸﾚｰ	
11	PMLT-0018QSZ1		AC	DJ		C	Transport screw cushion	搬送ｽｸﾚｰﾓﾙﾄ	
12	LFIX-0014QSZZ		AE	DJ		C	Drum fixing plate A(Refer to Matrix)	ﾄﾞﾗﾑ固定板A	
	LFIX-0015QSZZ		AE	DJ		C	Drum fixing plate B(Refer to Matrix)	ﾄﾞﾗﾑ固定板B	
13	MSPRC0639QSZZ		AE	DJ		C	Blade earth spring	ﾌﾞﾚｰﾄﾞｱｰｽﾞﾘﾝｸﾞ	
14	CPLTM0833QS01		AE	DS		C	Separate holder assy	剥離ﾓﾙﾀﾞｰｱｯｾﾝ	
15	PSHEZ0844QSZZ		AE	DS		C	Drum cleaner sheet	ﾄﾞﾗﾑｸﾘｰﾅｰｼｰﾄ	
16	PCOVP0222QSZ1		AG	DX		C	Process gear cover	ﾌﾟﾛｽﾞｷﾞｱｶﾊﾞｰ	
17	NGERH0037QSZZ		AC	DJ		C	Idle gear(26T)	ｱｲﾄﾞﾙｷﾞｱ	
18	NGERH0038QSZZ		AC	DJ		C	Transport pipe gear(15T)	搬送ﾊﾟｲﾌﾟｷﾞｱ	
19	NGERH0039QSZZ		AE	DS		B	Transport pipe gear(14T)	搬送ﾊﾟｲﾌﾟｷﾞｱ	
20	PPiPP0021QSZZ		AF	DS		C	Waste toner pipe	廃ﾄﾅｰﾊﾟｲﾌﾟ	
21	PSPAZ0696FCZZ		AC	DJ		C	P cap spacer	Pｷｯﾌﾟｽﾊﾟｰｻｰ	
22	NSRW-0010QSZZ		AE	DJ		C	Transport pipe screw	搬送ﾊﾟｲﾌﾟｽｸﾚｰ	
23	PCAPH0032QSZZ		AC	DD		C	Waste toner cap	廃ﾄﾅｰｷｯﾌﾟ	
24	NGERH0036QSZZ		AC	DJ		C	Transport screw gear(30T)	搬送ｽｸﾚｰｷﾞｱ	
25	MSPRC0045QSZ1		AC	DJ		C	Toner pipe spring	ﾄﾅｰﾊﾟｲﾌﾟｽﾌﾘﾝｸﾞ	
26	PSHT-0023QSZZ		AD	DD		C	Waste toner shutter	廃ﾄﾅｰｼｯﾀﾞ	
27	LFRM-0159QSZZ		AL	EB		C	MC frame	MCﾌﾚｰﾑ	
28	PTPE-0091QSZZ		AD	DD		C	MC case tape	MCｾｰｽﾃｰﾌﾟ	
29	PCASZ0023QSZZ		AE	DJ		C	MC case	MCｾｰｽ	
30	PTPE-0005QSZZ		AG	DJ		C	Saw blade tape	ﾉｼﾞﾈｰﾌﾟ	
31	LPLTM0929QSZZ		AK	DX	N	C	Saw blade	ﾉｼﾞ	
32	LPLTM0062QSZ1		AG	DS		A	Grid	ｸﾞﾘｯﾄﾞ	
33	QSLP-0033QSZ1		AC	DD		C	Saw blade terminal	ﾉｼﾞ端子	
34	QSLP-0032QSZZ		AC	DD		C	Grid terminal	ｸﾞﾘｯﾄﾞ端子	
35	LX-RZ0001QSZZ		AB	DD		A	Star ring	ｽﾀｰﾘﾝｸﾞ	
36	LHLDZ0276QSZZ		AC	DD		C	Star ring holder	ｽﾀｰﾘﾝｸﾞﾓﾙﾀﾞｰ	
37	PRNGF0106FCZ2		AC	DJ		C	Starling	ｽﾀｰﾘﾝｸﾞ	
38	PTME-0021QSZZ		AK	DX		C	Separator pawl	剥離爪	
39	LX-WZ0329FCPZ		AB	DD		C	Washer	ワｯｼﾞｰ	
	MSPRC4506QSZZ		AB	DD		C	Separation pawl spring	剥離爪ｽﾌﾟﾘﾝｸﾞ	
40	MSPRC4506QSZ1	1	AB	DD		C	Separation pawl spring	剥離爪ｽﾌﾟﾘﾝｸﾞ	Productivity improvement
41	LX-BZ0406FCPZ		AA	DD		C	Screw(3×4)	ﾋﾞｽ	
42	XEBS730P08000		AC	DD		C	Screw(3×8)	ﾋﾞｽ	
	PMLT-0250QSZ1		AC	DD		C	Seal cushion R	密封ﾓﾙﾄR	
43	PMLT-0282QSZZ	3	AD	DD	N	C	Toner seal cushion R	ﾄﾅｰ密封ﾓﾙﾄR	Improve performance
44	MLEVP0191QSZZ		AG	DX	N	C	Separation pawl lever	剥離爪ﾘﾊﾞｰ	
45	MSPRT0214QSZZ		AB	DJ		C	Lever spring	ﾘﾊﾞｰｽﾌﾟﾘﾝｸﾞ	
46	PMLT-0271QSZZ		AD	DJ	N	C	Flange cushion	ﾌﾗﾝｼﾞﾓﾙﾄ	
47	PSHEZ0927QSZZ		AC	DD	N	C	Lever damper cushion	ﾘﾊﾞｰ-消音ﾓﾙﾄ	
48	PSEL-0133QSZ1	-	AB	DD	N	C	TH cushion R	TH ﾓﾙﾄR	Missing parts code
49	LPLTM0938QSZZ	-	AE	DS	N	C	Holder support plate	ﾓﾙﾀﾞｰ-保持板	Missing parts code
50	PSHEZ0932QSZZ	-	AC	DD	N	C	Scattering prevention sheet F	飛散防止ｼｰﾄF	Missing parts code
51	PSHEZ0933QSZZ	-	AC	DD	N	C	Scattering prevention sheet R	飛散防止ｼｰﾄR	Missing parts code
52	PMLT-0280QSZZ	-	AB	DD	N	C	Scattering prevention cushion F	飛散防止ﾓﾙﾄF	Missing parts code
501	CCASZ0023RS51		AV	FG		E	MC unit	MC ﾆｯﾄ	
	(Unit)								
901	CFRM-0154RS53		BF	GN		E	Process unit	ﾌﾟﾛｽﾞ ﾆｯﾄ	

11 プロセスユニット (Process unit)

[AR-6031N,AR-6031NR,AR-6131N,AR-X311N,AR-6026N,AR-6026NR]

**Matrix**

No.12	ドラム固定板 A(Drum fixing plate A)	
PARTS CODE	Americas1 Asia Brazil Class B	Australia Europe Japan(日本)
LF i X-0014QSZZ		1st Lot
LF i X-0015QSZZ	1st Lot	



11 プロセスユニット (Process unit)  
 [AR-6031N,AR-6031NR,AR-6131N,AR-X311N,AR-6026N,AR-6026NR]

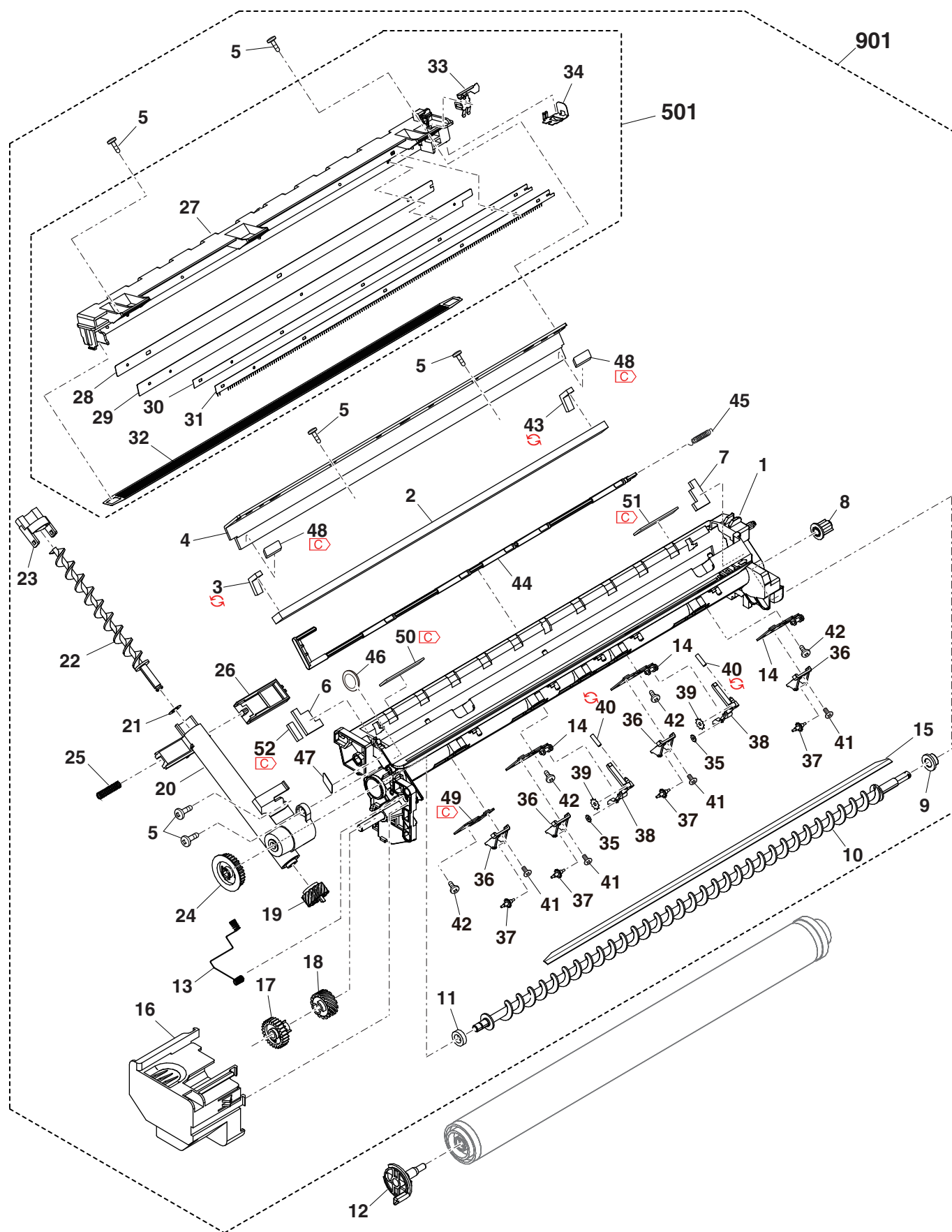

12) プロセスユニット (Process unit)[AR-6023N,AR-6023NR,AR-X231N,AR-6020N, AR-6020NR,AR-6120N,AR-6023D,AR-6020D,AR-X201D,AR-6023,AR-6020,AR-X201]

NO.	PARTS CODE	Inter-change	PRICE Ex.	RANK Ja.	NEW MARK	PART RANK	DESCRIPTION	Reason for change	Effective time
1	CFRM-0154QS05		AT	EZ	N	C	Process frame assy		
2	PMLT-0251QSZZ		AD	DJ	N	A	Blade side cushion		
3	PMLT-0252QSZZ		AC	DD		C	Seal cushion F		
4	CCLEZ0011QS32		BD	GN		A	Cleaning blade		
5	XEBS730P10000		AC	DD		C	Screw(3x10)		
6	PMLT-0254QSZZ		AF	DS	N	A	Drum red cushion F		
7	PMLT-0255QSZZ		AF	DS	N	A	Drum red cushion R		
8	NCPL-0003QSZ1		AC	DJ		C	Screw coupling		
9	NBRGP0299FCPZ		AD	DJ		C	CL bearing		
10	NSRW-0009QSZZ		AK	DX	N	C	Waste toner transport screw		
11	PMLT-0018QSZ1		AC	DJ		C	Transport screw cushion		
12	LFIX-0014QSZZ		AE	DJ		C	Drum fixing plate A(Refer to Matrix)		
	LFIX-0015QSZZ		AE	DJ		C	Drum fixing plate B(Refer to Matrix)		
13	MSPRC0639QSZZ		AE	DJ	N	C	Blade earth spring		
14	★CPLTM0833QS01	-	AE	DS	N	C	Separate holder assy	Improve performance	15/Jan
	CPLTM0833QS01		AE	DS	N	C	Separate holder assy		
15	PSHEZ0844QSZZ		AE	DS	N	C	Drum cleaner sheet		
	PCOVP0222QSZZ		AG	DX	N	C	Process gear cover		
16	PCOVP0222QSZ1	3	AG	DX		C	Process gear cover	Improve performance	14/Oct
17	NGERH0037QSZZ		AC	DJ		C	Idle gear(26T)		
18	NGERH0038QSZZ		AC	DJ		C	Transport pipe gear(15T)		
19	NGERH0039QSZZ		AE	DS		B	Transport pipe gear(14T)		
20	PIPP0021QSZZ		AF	DS	N	C	Waste toner pipe		
21	PSPAZ0696FCZZ		AC	DJ		C	P cap spacer		
22	NSRW-0010QSZZ		AE	DJ	N	C	Transport pipe screw		
23	PCAPH0032QSZZ		AC	DD	N	C	Waste toner cap		
24	NGERH0036QSZZ		AC	DJ		C	Transport screw gear(30T)		
25	MSPRC0045QSZ1		AC	DJ		C	Toner pipe spring		
26	PSHT-0023QSZZ		AD	DD	N	C	Waste toner shutter		
27	LFRM-0159QSZZ		AD	EB	N	C	MC frame		
28	PTPE-0091QSZZ		AL	DD	N	C	MC case tape		
29	PCASZ0023QSZZ		AE	DJ	N	C	MC case		
30	PTPE-0005QSZZ		AG	DJ		C	Saw blade tape		
	LPLTM0386QSZZ		AG	DX		C	Saw blade		
31	LPLTM0929QSZZ	3	AK	DX	N	C	Saw blade	Improve performance	14/Nov
32	LPLTM0062QSZ1		AG	DS		A	Grid		
	QSLP-0033QSZZ		AC	DD	N	C	Saw blade terminal		
33	QSLP-0033QSZ1	3	AC	DD	N	C	Saw blade terminal	Improve performance	14/Nov RC
34	QSLP-0032QSZZ		AC	DD	N	C	Grid terminal		
35	LX-RZ0001QSZZ		AB	DD		A	Star ring		
36	LHLDZ0276QSZZ	-	AC	DD	N	C	Star ring holder	Missing parts code	1st lot
37	PRNGF0106FCZ2		AC	DJ	N	C	Starling		
	PTME-0021QSZZ		AK	DX	N	C	Separator pawl		
38	PTME-0046QSZZ	3	AF	DS		A	Separator pawl	Improve performance	14/Nov
39	LX-WZ0329FCPZ	-	AB	DD		C	Washer	Improve performance	14/Nov
	MSPRC0213QSZZ		AB	DJ		C	Separation pawl spring		
40	MSPRC4506QSZZ	-	AB	DD	N	C	Separation pawl spring	Parts code correction	1st lot
	MSPRC4506QSZZ	-	AB	DD	N	C	Separation pawl spring	Improve performance	14/Nov
41	LX-BZ0406FCPZ		AA	DD		C	Screw(3x4)		
42	XEBS730P08000		AC	DD		C	Screw(3x8)		
43	PMLT-0250QSZ1		AC	DD	N	C	Seal cushion R		
44	LHLDZ0254QSZZ	-	AD	DJ	N	C	Separation pawl holder	Improve performance	14/Nov
45	LPLTM0938QSZZ	-	AE	DS	N	C	Holder support plate	Improve performance	15/Jan
501	CCASZ0023RS51		AV	FG	N	E	MC unit		
	(Unit)								
	CFRM-0154RS52		BE	GN	N	E	Process unit		
901	CFRM-0154RS55	3	BF	GN	N	E	Process unit	Improve performance	14/Nov

12 プロセスユニット (Process unit)[AR-6023N,AR-6023NR,AR-X231N,AR-6020N,  
AR-6020NR,AR-6120N,AR-6023D,AR-6020D,AR-X201D,AR-6023,AR-6020,AR-X201]

**Matrix**

No.12		ドラム固定板 A(Drum fixing plate A)	
PARTS CODE	Americas1 Asia Brazil Class B	Australia Europe Japan(日本)	
LF i X-0014QSZZ			1st Lot
LF i X-0015QSZZ	1st Lot		

12 プロセスユニット (Process unit)[AR-6023N,AR-6023NR,AR-X231N,AR-6020N,AR-6020NR,AR-6120N,AR-6023D,AR-6020D,AR-X201D,AR-6023,AR-6020,AR-X201]

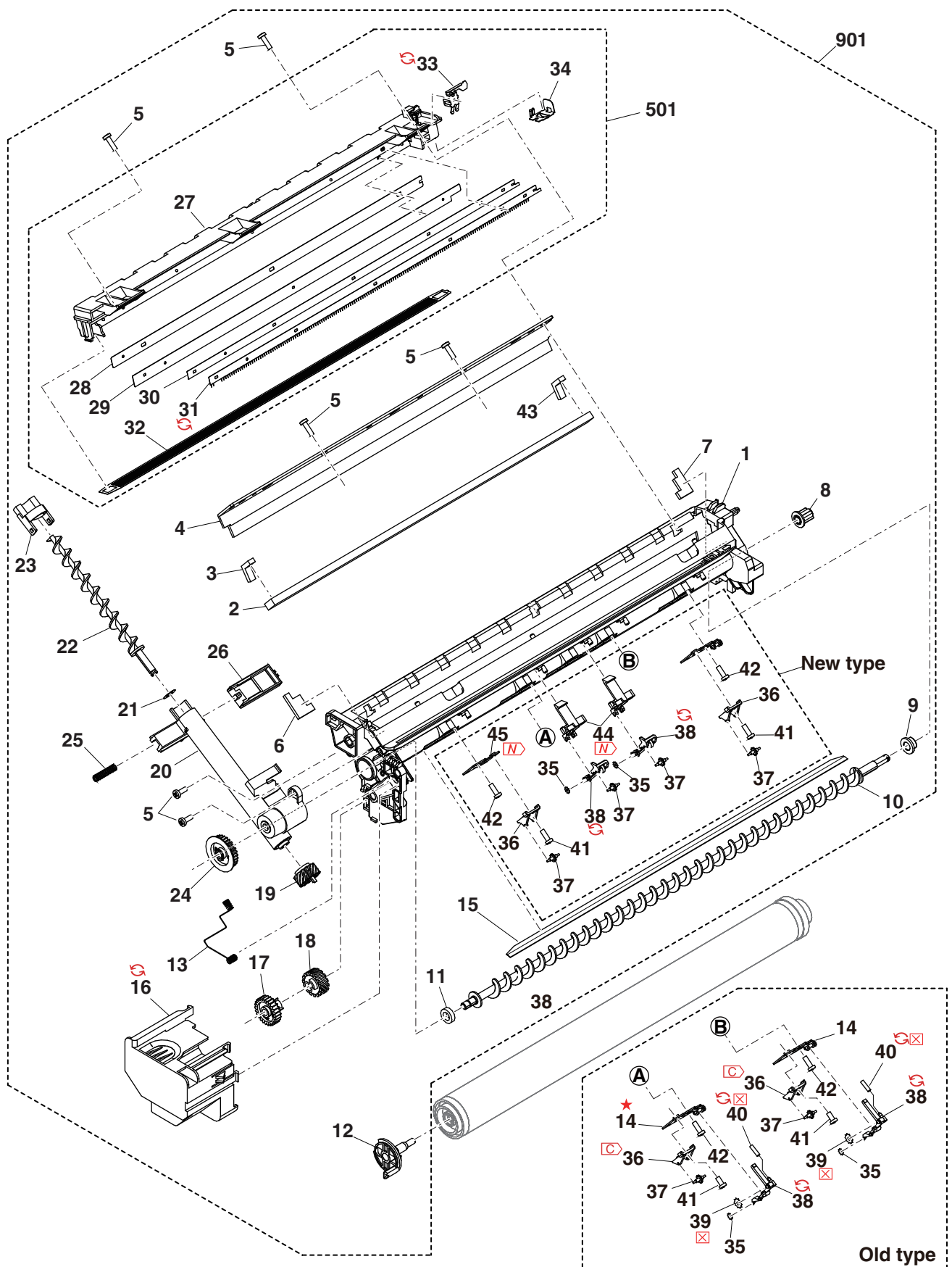

13 DV ユニット (DV unit)

NO.	PARTS CODE	Inter-change	PRICE Ex.	RANK Ja.	NEW MARK	PART RANK	DESCRIPTION	Reason for change	Effective time
1	PBOX-0025QSZ1		AM	EG		C	DV BOX		
2	NR0LM0151QSZZ		BC	GD		B	MG roller		
3	NR0LP0238QSZZ		AR	EQ	N	C	MX roller R(Refer to Matrix)		
	NR0LP0149QSZZ		AS	EQ		C	MX roller R(Refer to Matrix)		
4	NR0LP0150QSZZ		AS	EQ		C	MX roller L(Refer to Matrix)		
	NR0LP0239QSZZ		AR	EQ	N	C	MX screw L(Refer to Matrix)		
5	PGiDM0247QSZZ		AQ	EQ	N	C	Cartridge guide lower		
6	CHLDZ0142RS52		AP	EQ	N	A	Filter holder unit		
7	PGiDM0246QSZZ		AG	DX	N	C	Cartridge guide upper		
8	XEBS730P08000		AC	DD		C	Screw(3x8)		
9	XRESP40-06000		AA	DD		C	E type ring(E4)		
10	NBRGC0770FCZZ		AH	DX		C	DMX bearing(6/14)		
11	LDAiU0033QSZZ		AC	DJ		C	DV block R		
12	LPLTM0194QSZZ		AC	DJ		C	DV box fixing plate		
13	NPLYZ0040QSZZ		AC	DJ		C	MG pulley		
14	NBLTH0494FCZZ		AD	DJ		B	DV belt B		
15	NPLYZ0041QSZZ		AC	DJ		C	MX pulley		
16	PMLT-0147QSZZ		AB	DJ		C	DV side cushion R		
17	NGERH1653FCZZ		AC	DJ		C	DMX gear(24T)		
18	PCOVP0121QSZ1		AE	DJ		C	Doctor cover		
19	LPLTM0477QSZZ		AK	EB		C	DV doctor		
20	LPLTM0820QSZZ		AQ	EQ	N	C	Doctor reinforce plate		
21	MSPRD0651QSZZ		AE	DJ	N	C	DV high voltage spring F		
22	RDTCM0021QSZZ		AY	FQ		B	ATC sensor		
23	XUBUZ30P08000		AA	DD		C	Screw(3x8)		
24	PCOVP0122QSAZ		AH	DX		D	DV cover F(Refer to Matrix)		
	PCOVP0122QSZZ		AF	DS		D	DV cover F(Refer to Matrix)		
25	LHLDZ0129QSZZ		AC	DJ		C	MG holder		
26	MSPRD0395QSZ1		AC	DD		C	Bias spring		
27	LHLDZ0128QSZZ		AC	DJ		C	DV holder F		
28	XEBS730P10000		AC	DD		C	Screw(3x10)		
29	XBPBZ30P03000		AB	DD		C	Screw(3x3)		
30	LPLTM0765QSZZ		AD	DJ	N	C	DV high voltage terminal		
31	XBBBZ30P06000		AC	DD		C	Screw(3x6)		
32	LX-BZ1143FCPZ		AD	DJ		C	Process fixing screw		
33	XRESP50-06000		AA	DD		C	E type ring(E5)		
34	XBPS730P06KS0		AB	DD		C	Screw(3x6K)		
35	PMLT-0146QSZZ		AB	DJ		C	DV side cushion F		
36	PMLT-0141QSZZ		AC	DJ		C	DV guide cushion N		
37	LX-BZ1066FCZZ		AC	DD		C	Screw(3x6)		
38	LHLDZ0132QSZ1		AC	DJ		C	Scraper holder		
39	XEBS730P06000		AA	DD		C	Screw(3x6)		
40	PSHEZ0651QSZZ		AA	DJ		A	DV side sheet R		
41	PSHEZ0652QSZZ		AA	DJ		A	DV side sheet F		
42	MSPRD0652QSZZ		AE	DS	N	C	DV high voltage spring R		
43	PMLT-0137QS11		AC	DJ		C	Pipe cushion N		
44	PMLT-0142QSZZ		AC	DJ		C	Pipe cover cushion N		
45	PSEL-0964FCZ1		AA	DJ		C	Cover upper seal		
46	PMLT-0002YSZ1		AC	DJ		C	DV TH cushion		
47	PSHEP0632QSZZ		AB	DJ		C	Doctor cover seal		
48	PSEL-0162QSZZ		AE	DJ		A	DV blade seal		
49	LX-WZ0020QSZZ		AC	DJ	N	C	DV Washer [AR-6031N,AR-6031NR,AR-6131N, AR-X311N,AR-6026N,AR-6026NR]		
50	NBRGC0770FCZZ		AH	DX		C	DMX bearing(6/14)(Refer to Matrix)		
	NBRGY0769FCZ2		AQ	EB		B	MG bearing(Refer to Matrix)		
51	NBRGC0020QSZZ		AH	DX		C	Bearing(Refer to Matrix)		
	NBRGC0770FCZZ		AH	DX		C	DMX bearing(6/14)(Refer to Matrix)		
52	PMLT-0272QSZZ		AB	DD	N	C	DV seal cushion [AR-6031N,AR-6031NR,AR-6131N, AR-X311N,AR-6026N,AR-6026NR]		
53	PSHEZ0920QSZZ		AB	DD	N	C	DG blade sheet [AR-6031N,AR-6031NR,AR-6131N, AR-X311N,AR-6026N,AR-6026NR]		
54	PMLT-0279QSZZ		AB	DD	N	C	TN guide lower seal [AR-6031N,AR-6031NR,AR-6131N, AR-X311N,AR-6026N,AR-6026NR]		
55	PMLT-0278QSZZ		AC	DD	N	C	DV seal F [AR-6031N,AR-6031NR,AR-6131N, AR-X311N,AR-6026N,AR-6026NR]		
	(Unit)								
901	DUNT-1257RS13		BP	LP	N	E	DV unit(Refer to Matrix)		
	DUNT-1257RSZZ		BP	LP	N	E	DV unit(Refer to Matrix)		

13 DV ユニット (DV unit)

Matrix

No.3		MX ロール R (MX roller R)
PARTS CODE	AR-6031N AR-6031NR AR-6131N AR-X311N AR-6026N AR-6026NR	AR-6023N AR-6023NR AR-X231N AR-6020N AR-6020NR AR-6120N AR-6023D AR-6020D AR-X201D AR-6023 AR-6020 AR-X201 AR-G200
NRÖLP0149QSZZ	1st Lot	
NRÖLP0238QSZZ		1st Lot

No.4		MX ロール L (MX roller L)
PARTS CODE	AR-6031N AR-6031NR AR-6131N AR-X311N AR-6026N AR-6026NR	AR-6023N AR-6023NR AR-X231N AR-6020N AR-6020NR AR-6120N AR-6023D AR-6020D AR-X201D AR-6023 AR-6020 AR-X201 AR-G200
NRÖLP0150QSZZ	1st Lot	
NRÖLP0239QSZZ		1st Lot

No.50		ベアリング (Bearing)
PARTS CODE	AR-6031N AR-6031NR AR-6131N AR-X311N AR-6026N AR-6026NR	AR-6023N AR-6023NR AR-X231N AR-6020N AR-6020NR AR-6120N AR-6023D AR-6020D AR-X201D AR-6023 AR-6020 AR-X201 AR-G200
NBRGC0770FCZZ		1st Lot
NBRGY0769FCZ2	1st Lot	

No.51		ベアリング (Bearing)
PARTS CODE	AR-6031N AR-6031NR AR-6131N AR-X311N AR-6026N AR-6026NR	AR-6023N AR-6023NR AR-X231N AR-6020N AR-6020NR AR-6120N AR-6023D AR-6020D AR-X201D AR-6023 AR-6020 AR-X201 AR-G200
NBRGC0020QSZZ	1st Lot	
NBRGC0770FCZZ		1st Lot

No.24		DV カバ F (DV cover F)
PARTS CODE	AR-6031N AR-6031NR AR-6131N AR-X311N AR-6026N AR-6026NR	AR-6023N AR-6023NR AR-X231N AR-6020N AR-6020NR AR-6120N AR-6023D AR-6020D AR-X201D AR-6023 AR-6020 AR-X201 AR-G200
PCÖVP0122QSAZ	1st Lot	
PCÖVP0122QSZZ		1st Lot

No.901		DV ユニット (DV unit)
PARTS CODE	AR-6031N AR-6031NR AR-6131N AR-X311N AR-6026N AR-6026NR	AR-6023N AR-6023NR AR-X231N AR-6020N AR-6020NR AR-6120N AR-6023D AR-6020D AR-X201D AR-6023 AR-6020 AR-X201 AR-G200
DUNT-1257RS13	1st Lot	
DUNT-1257RSZZ		1st Lot

13 DV ユニット (DV unit)

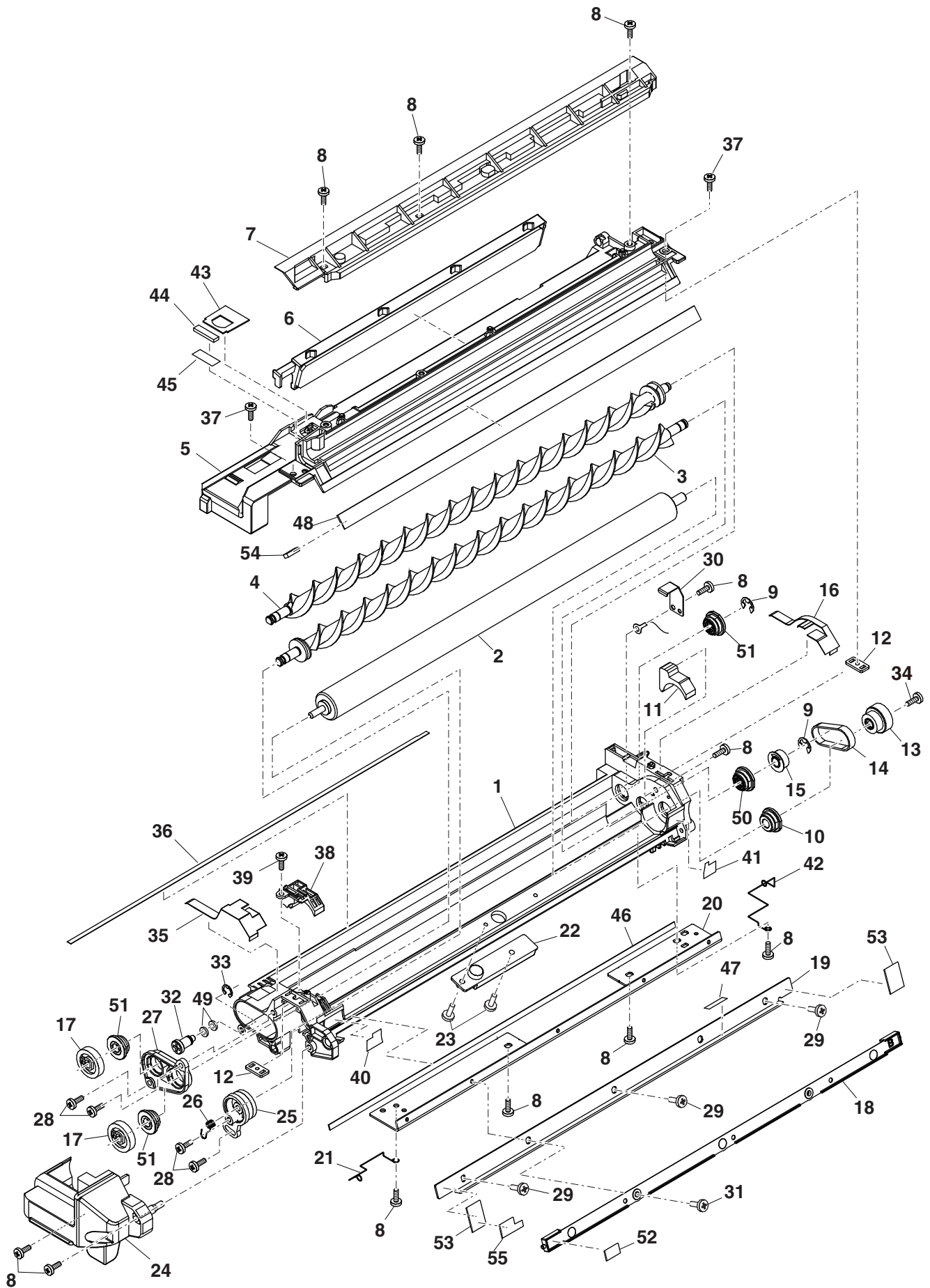



14 定着ユニット (Fusing unit)

[AR-6031N,AR-6031NR,AR-6131N,AR-X311N,AR-6026N,AR-6026NR]

NO.	PARTS CODE	Inter-change	PRICE Ex.	RANK Ja.	NEW MARK	PART RANK	DESCRIPTION	Reason for change	Effective time
1	CPLTM0805QS01		AL	EB	N	C	Fusing frame R	定着フレーム R	
2	MLEVF0179QSZZ		AD	DJ		C	Pressure lever R	加圧レバ <sup>°</sup> -R	
3	MSPRC0668QSZZ		AD	DD	N	C	Fusing pressure spring	定着加圧スプリング <sup>°</sup>	
4	LX-BZ0862FCPZ		AC	DD		C	Pressure plate fulcrum screw	圧接板支点ビス	
5	MLEVP0187QSA1		AD	DJ	N	C	Pressure release lever F	圧解除レバ <sup>°</sup> -F	
6	CPLTM0804QS01		AL	EB	N	C	Fusing frame F	定着フレーム F	
7	MLEVF0178QSZZ		AD	DJ		C	Pressure lever F	加圧レバ <sup>°</sup> -F	
8	MLEVP0188QSA2		AD	DJ	N	C	Pressure release lever R	圧解除レバ <sup>°</sup> -R	
9	LSTYM0021QSZZ		AN	EG	N	C	Fusing upper frame stay	定着上フレームステー	
10	XHBS730P06000		AC	DD		C	Screw(3x6)	ビス	
11	NROLR0156QSAZ		BF	GN		C	Pressure roller	加圧ローラー	
12	NBRGY0022QSZZ		AL	EB		A	FU pressure bearing	FU 加圧軸受	
13	NROLM0129QSZZ		BB	FX		A	Heat roller(TL)	ヒートローラー	
13	NBRGP0093QSZ1		AH	DX	N	C	Fusing upper HR bearing	定着上 HR 軸受	
14	NBRGP0093QSA1	3	AH	DX	N	C	Fusing upper HR bearing	定着上 HR 軸受	Improve performance 15/Jan RC
15	NGERH0171QSZZ		AR	EQ		A	Fusing gear(TL)(38T)	定着ギヤ	
16	LSTPF0172FCZZ		AA	DD		C	Roller stopper	ローラーストップ <sup>°</sup> -	
17	LFRM-0157QSZZ		AQ	EQ		C	Fusing lower frame	定着下フレーム	
18	LHLDZ0277QSZZ		AG	DX	N	C	Lamp fixing plate R	ランプ取付板 R	
18	VHPSG2A141+-1		AF	DS		B	Photo sensor(SG2A141)	フォトセナー	
19	VHPSG2A241+-1	1			N	B	Photo sensor(SG2A241)	フォトセナー	Productivity improvement 15/Jan
20	XBBS730P08000		AA	DD		C	Screw(3x8)	ビス	
21	CPLTM0855QS01		AT	EZ	N	C	Fusing cleaner plate	定着クリーナー板	
22	LPLTM0816QSZ1		AG	DX	N	C	Fusing upper plate	定着上板	
23	TLABH0289QSZZ		AA	DJ		D	Fusing green label	定着グリーンラベル	
24	MLEVP0192QSZZ		AG	DX	N	C	Fusing rear paper detect lever	定着後用紙検知レバ <sup>°</sup> -	
25	MSPRD0322QSZZ		AC	DJ		C	Fusing ACT return spring	定着 ACT 復帰スプリング <sup>°</sup>	
26	PGiDM0264QSZ1		AN	EQ	N	C	Fusing rear upper paper guide	定着後上 <sup>°</sup> -レバ <sup>°</sup> -ガイド	
26	PGiDM0264QSZ2	3	AN	EQ	N	C	Fusing rear upper paper guide	定着後上 <sup>°</sup> -レバ <sup>°</sup> -ガイド	Improve performance 15/Jan RC
27	PTME-0039QSZZ		AE	DS		A	Upper separator pawl	上剥離爪	
28	MSPRT0086QSZZ		AB	DJ		C	Upper pawl pressure spring	上爪加圧スプリング <sup>°</sup>	
29	LX-BZ0676FCZZ		AA	DD		C	Screw(4x10 Blue)	ビス	
30	PGiDM0249QSZ1		AP	EQ		C	Fusing rear lower guide	定着後下ガイド	
31	LHLDZ0278QSZ1		AG	DX	N	C	Lamp fixing plate F	ランプ取付板 F	
32	MSPRD0326QSZZ		AC	DJ		C	PG cleaner	定着後下 PG 拭き	
33	LX-BZ1127FCPZ		AC	DD		C	Joint plate fixing step screw	ジョイントプレート取付段ビス	
34	LX-BZ1195FCZZ		AC	DD		C	Step screw	段ビス	
35	LX-BZ0759FCPZ		AC	DD		C	Step screw(M3)	段ビス	
37	PBRSS0276FCZZ	-	AC	DD		B	Fusing lower discharge brush	定着下除電ブラシ	Improve performance 15/Jan RC
38	PGiDH0262QSZZ		AQ	EQ		C	Fusing front paper guide	定着前 <sup>°</sup> -レバ <sup>°</sup> -ガイド	
39	LFRM-0156QSZ4		AQ	EQ	N	C	Fusing frame	定着フレーム	
40	RLMPU0059QSZZ		BF	GN	N	B	Heater lamp(Refer to Matrix)	ヒーターランプ	
40	RLMPU0060QSZZ		BF	GN	N	B	Heater lamp(Refer to Matrix)	ヒーターランプ	
40	RLMPU0058QSZZ		BF	GN	N	B	Heater lamp(Refer to Matrix)	ヒーターランプ	
41	PCOVP0173QSZZ		AD	DJ		C	Thermostat cover	サーモスタットカバー	
42	VRH-ST2HB507K		AD	DJ		C	Resistor(500MΩ)	抵抗	
43	RTHM-0050FCZ1		AM	EG		B	Upper thermostat	上サーモスタット	
44	LX-BZ1181FCZZ		AB	DD		C	Screw(3x6)	ビス	
45	XHPS730P04000		AB	DD		C	Screw(3x4)	ビス	
46	XWHS730-05080		AA	DD		C	Washer(M3)	ワッシャー	
47	RH-HX0001QSLB		AT	EZ		B	Thermistor TL	サーミスタ TL	
47	LX-BZ1126FCPZ		AB	DD		C	Thermistor screw	サーミスタビス	
48	XBPS730P10KS0	3	AB	DD		C	Screw(3x10KS)	ビス	Improve performance 15/Apr RC
49	XEBS730P08000		AC	DD		C	Screw(3x8)	ビス	
50	TLABH0685QSZZ		AD	DJ		D	High temperature caution label (Refer to Matrix)	高温注意ラベル	
50	TLABH0686QSZZ		AD	DJ		D	High temperature caution label (Refer to Matrix)	高温注意ラベル	
51	PTME-0041QSZZ		AG	DS		C	Under separator pawl	下剥離爪	
52	MSPRD0398QSZZ		AC	DJ		C	Under pawl SP	下爪剥離 SP	
53	LPLTM0343QSZZ		AB	DJ		C	Gear key	ギヤキー	
54	LX-WZ0021QSZZ		AB	DJ		C	Ring	スリッパ <sup>°</sup> -リング	
55	PCLR-0501FCZZ	-	AB	DJ		C	Delivery guide collar	排紙ガイド <sup>°</sup> コリ	Improve performance 15/Jan RC
56	LX-WZ0001QSZZ	-	AC	DD		C	Separator pawl washer	剥離爪ワッシャー	Improve performance 15/Jan RC
	(Unit)								
901	DUNTW1275RS11		BV	NU	N	E	Fusing unit(Refer to Matrix)	定着ユニット	
901	DUNTW1275RS12		BV	NU	N	E	Fusing unit(Refer to Matrix)	定着ユニット	
901	DUNTW1333RS11	1	BW	RJ	N	E	Fusing unit(Refer to Matrix)	定着ユニット	Productivity improvement 15/Jan
901	DUNTW1333RS12	1	BW	RJ	N	E	Fusing unit(Refer to Matrix)	定着ユニット	Productivity improvement 15/Jan



14 定着ユニット (Fusing unit)

[AR-6031N,AR-6031NR,AR-6131N,AR-X311N,AR-6026N,AR-6026NR]

NO.	PARTS CODE	Inter-change	PRICE RANK		NEW MARK	PART RANK	DESCRIPTION	Reason for change	Effective time
			Ex.	Ja.					
901	DUNTW1333US13		CA	TR	N	E	Fusing unit(Refer to Matrix) 定着ユニット		

Matrix

No.40		ヒーターランプ (Heater lamp)		
PARTS CODE	120V	200V series	110V	
RLMPU0058QSZZ			1st Lot	
RLMPU0059QSZZ	1st Lot			
RLMPU0060QSZZ		1st Lot		

No.50		高温注意ラベル (High temperature caution label)		
PARTS CODE	Americas1 Europe Asia Brazil SouthAfrica Namibia	Taiwan		
TLABH0685QSZZ	1st Lot			
TLABH0686QSZZ		1st Lot		

No.901		定着ユニット (Fusing unit)		
PARTS CODE	120V	200V series	110V	
DUNTW1275RS11	1st Lot			
DUNTW1275RS12		1st Lot		
DUNTW1333RS11	15/Jun			
DUNTW1333RS12		15/Jun		
DUNTW1333US13			1st Lot	

14 定着ユニット (Fusing unit)  
 [AR-6031N,AR-6031NR,AR-6131N,AR-X311N,AR-6026N,AR-6026NR]

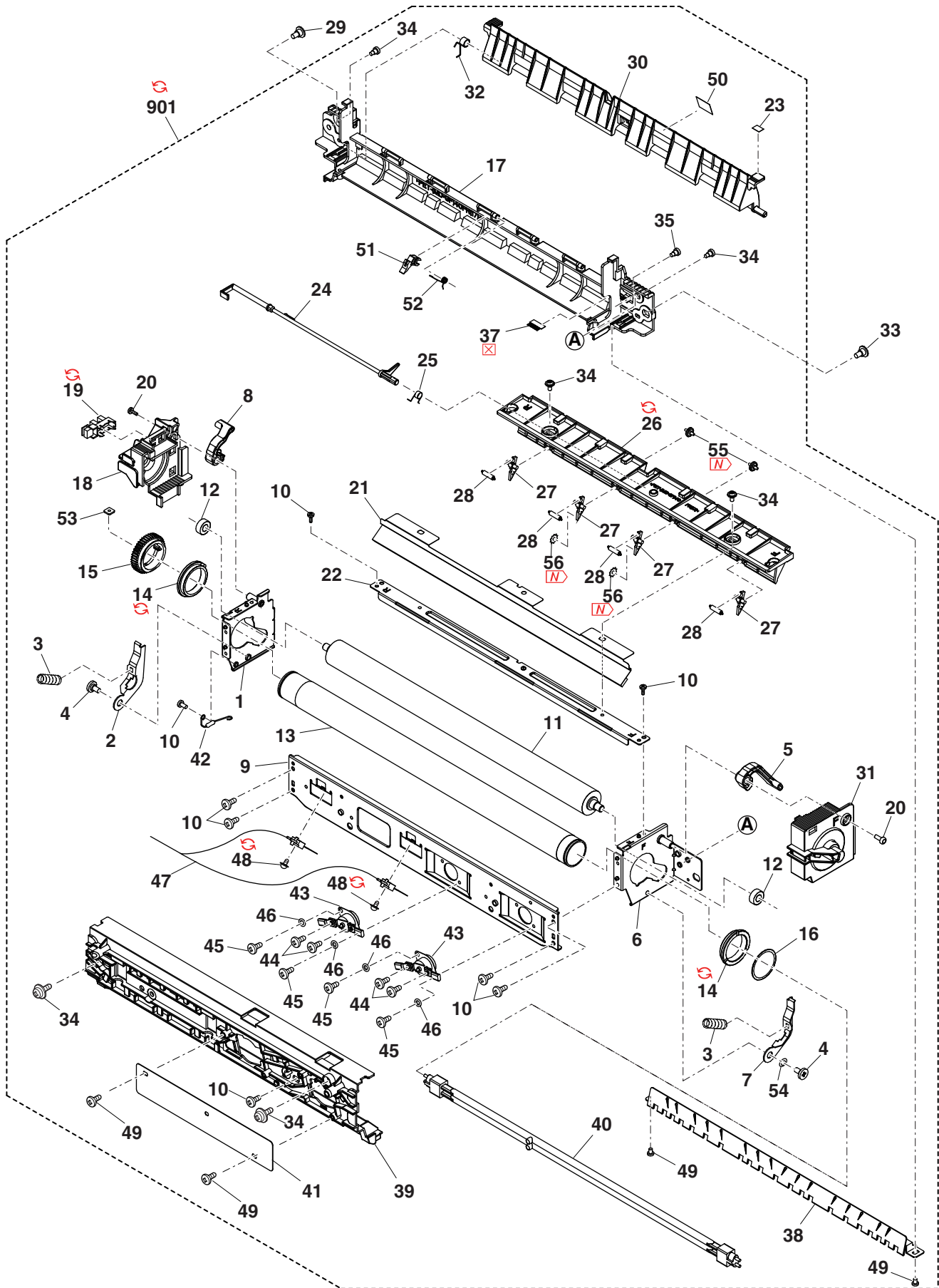

15) 定着ユニット (Fusing unit)[AR-6023N,AR-6023NR,AR-X231N,AR-6020N,  
AR-6020NR,AR-6120N,AR-6023D,AR-6020D,AR-X201D,AR-6023,AR-6020,AR-X201]

NO.	PARTS CODE	Inter-change	PRICE Ex.	RANK Ja.	NEW MARK	PART RANK	DESCRIPTION	Reason for change	Effective time
1	CPLTM0803QS02		AL	EB	N	C	Fusing frame R 定着フレーム R		
2	MLEVF0179QSZZ		AD	DJ	N	C	Pressure lever R 加圧レバ <sup>o</sup> -R		
3	MSPRC0650QSZZ		AD	DD	N	C	Fusing pressure spring 定着加圧スプリング <sup>o</sup>		
4	LX-BZ0862FCPZ		AC	DD		C	Pressure plate fulcrum screw 圧接板支点ビス		
	MLEVP0187QSZZ		AD	DJ		C	Pressure release lever F 圧解除レバ <sup>o</sup> -F		
5	⊕ MLEVP0187QSZ1	-	AD	DJ	N	C	Pressure release lever F 圧解除レバ <sup>o</sup> -F	Parts code correction	1st lot
	⊕ MLEVP0187QSA1	3	AD	DJ	N	C	Pressure release lever F 圧解除レバ <sup>o</sup> -F	Improve performance	14/Nov
6	CPLTM0802QS02		AL	EB	N	C	Fusing frame F 定着フレーム F		
7	MLEVF0178QSZZ		AD	DJ	N	C	Pressure lever F 加圧レバ <sup>o</sup> -F		
	MLEVP0188QSZZ		AD	DJ		C	Pressure release lever R 圧解除レバ <sup>o</sup> -R		
8	⊕ MLEVP0188QSZ1	-	AD	DJ	N	C	Pressure release lever R 圧解除レバ <sup>o</sup> -R	Parts code correction	1st lot
	⊕ MLEVP0188QSA2	3	AD	DJ	N	C	Pressure release lever R 圧解除レバ <sup>o</sup> -R	Improve performance	14/Nov
9	LSTYM0020QSZZ		AL	EB	N	C	Fusing upper frame stay 定着上フレームステイ		
10	XHBS730P06000		AC	DD		C	Screw(3×6) ビス		
11	NROLR0156QSAZ		BF	GN		C	Pressure roller 加圧ローラー		
12	NBRGY0022QSZZ		AL	EB	A	A	FU pressure bearing FU 加圧軸受		
13	NROLI0187QSZZ		BA	FX		C	Upper heat roller 上ヒートローラー		
14	NBRGP0567FCZZ		AG	DX		A	Fusing bearing 定着軸受		
15	NGERH0221QSZZ		AF	DS		C	Fusing gear 定着ギヤ		
16	LSTPP0116FCZZ		AA	DD		C	Roller stopper ローターストップ <sup>o</sup> -		
17	LFRM-0157QSZZ		AQ	EQ	N	C	Fusing lower frame 定着下フレーム		
18	LHLDZ0256QSZZ		AH	DX	N	C	Lamp fixing plate R ランプ取付板 R		
	VHPSG2A141+-1		AF	DS		B	Photo sensor(SG2A141) フォトセナー		
19	⊕ VHPSG2A241+-1	1			N	B	Photo sensor(SG2A241) フォトセナー	Productivity improvement	15/Jun
20	XBBS730P08000		AA	DD		C	Screw(3×8) ビス		
	CPLTM0766QS02		AS	EQ	N	C	Fusing cleaner plate 定着クリーナー板		
21	⊕ CPLTM0766QS03	3	AS	EQ	N	C	Fusing cleaner plate 定着クリーナー板	Improve performance	14/Nov
	LPLTM0816QSZZ		AG	DX	N	C	Fusing upper plate 定着上板		
22	⊕ LPLTM0816QSZ1	3	AG	DX	N	C	Fusing upper plate 定着上板	Improve performance	14/Nov
23	TLABH0289QSZZ		AA	DJ		D	Fusing green label 定着グリーンラベル		
24	MLEVP0186QSZZ		AF	DS	N	C	Fusing rear paper detect lever 定着後用紙検知レバ <sup>o</sup> -		
25	MSPRD0322QSZZ		AC	DJ		C	Fusing ACT return spring 定着 ACT 復帰スプリング <sup>o</sup>		
	PGiDM0248QSZZ		AP	EQ	N	C	Fusing rear upper paper guide 定着後上 <sup>o</sup> -レバ <sup>o</sup> -ガイド		
26	⊕ PGiDM0248QSZ1	3	AP	EQ	N	C	Fusing rear upper paper guide 定着後上 <sup>o</sup> -レバ <sup>o</sup> -ガイド	Improve performance	14/Nov
	⊕ PGiDM0248QSZ2	3	AP	EQ	N	C	Fusing rear upper paper guide 定着後上 <sup>o</sup> -レバ <sup>o</sup> -ガイド	Improve performance	15/Jan RC
27	PTME-0039QSZZ		AE	DS		A	Upper separator pawl 上剥離爪		
28	MSPRT0086QSZZ		AB	DJ		C	Upper pawl pressure spring 上爪加圧スプリング <sup>o</sup>		
29	LX-BZ0676FCZZ		AA	DD		C	Screw(4×10 Blue) ビス		
	PGiDM0249QSZZ		AP	EQ	N	C	Fusing rear lower guide 定着後下ガイド		
30	⊕ PGiDM0249QSZ1	3	AP	EQ		C	Fusing rear lower guide 定着後下ガイド	Improve performance	14/Dec
31	LHLDZ0257QSZZ		AG	DX	N	C	Lamp fixing plate F ランプ取付板 F		
32	MSPRD0326QSZZ		AC	DJ		C	PG cleaner 定着後下 PG 拭き		
33	LX-BZ1127FCPZ		AC	DD		C	Joint plate fixing step screw ジョイントプレート取付段ビス		
34	LX-BZ1195FCZZ		AC	DD		C	Step screw 段ビス		
35	LX-BZ0759FCPZ		AC	DD		C	Step screw(M3) 段ビス		
36	PSHEZ0872QSZZ		AC	DD	N	C	Fusing earth sheet 定着アースシート		
37	PBRSS0276FCZZ		AC	DD	B	B	Fusing lower discharge brush 定着下除電ブラシ		
38	PGiDH0262QSZZ		AQ	EQ	N	C	Fusing front paper guide 定着前 <sup>o</sup> -レバ <sup>o</sup> -ガイド		
	LFRM-0156QSZZ		AQ	EQ	N	C	Fusing frame 定着フレーム		
39	⊕ LFRM-0156QSZ1	3	AQ	EQ	N	C	Fusing frame 定着フレーム	Improve performance	14/Nov
	⊕ LFRM-0156QSZ3	3	AQ	EQ	N	C	Fusing frame 定着フレーム	Improve performance	15/Dec RC
	RLMPU0053QSZZ		BA	FX	N	B	Heater lamp(Refer to Matrix) ヒーターランプ		
	RLMPU0054QSZZ		BB	GD	N	B	Heater lamp(Refer to Matrix) ヒーターランプ		
	RLMPU0055QSZZ		BA	FX	N	B	Heater lamp(Refer to Matrix) ヒーターランプ		
	RLMPU0056QSZZ		BA	FX	N	B	Heater lamp(Refer to Matrix) ヒーターランプ		
41	PCOVP0235QSZZ		AE	DJ	N	C	Thermostat cover サーマスタットカバー		
42	VRH-ST2HB507K		AD	DJ		C	Resistor(500MΩ) 抵抗		
43	RTHM-0010QSZZ		AM	EG	N	B	Upper thermostat 上サーモスタット		
44	LX-BZ1181FCZZ		AB	DD		C	Screw(3×6) ビス		
45	XHPS730P04000		AB	DD		C	Screw(3×4) ビス		
46	XWHS730-05080		AA	DD		C	Washer(M3) ワッシャー		
47	RH-HX0001QSLB		AT	EZ		B	Thermistor TL サーマスタット TL		
	LX-BZ1126FCPZ		AB	DD		C	Thermistor screw サーマスタットビス		
48	⊕ XBPS730P10KS0	3	AB	DD		C	Screw(3×10KS) ビス	Improve performance	15/Apr RC
49	XEBS730P08000		AC	DD		C	Screw(3×8) ビス		
50	TLABH0683QSZZ		AE	DJ		D	High temperature caution label (Refer to Matrix) 高圧注意ラベル		

△  
△  
△  
△  
△  
△  
△

15 定着ユニット (Fusing unit)[AR-6023N,AR-6023NR,AR-X231N,AR-6020N, AR-6020NR,AR-6120N,AR-6023D,AR-6020D,AR-X201D,AR-6023,AR-6020,AR-X201]

NO.	PARTS CODE	Inter-change	PRICE RANK		NEW MARK	PART RANK	DESCRIPTION	Reason for change	Effective time
			Ex.	Ja.					
50	TLABH0685QSZZ		AD	DJ		D	High temperature caution label (Refer to Matrix) 高温注意ラベル		
	TLABH0686QSZZ		AD	DJ		D	High temperature caution label (Refer to Matrix) 高温注意ラベル		
51	PTME-0041QSZZ		AG	DS	N	C	Under separator pawl 下剥離爪		
52	MSPRD0398QSZZ		AC	DJ		C	Under pawl SP 下爪剥離 SP		
55	▷PCLR-0501FCZZ	-	AB	DJ		C	Delivery guide collar 排紙ガイド	Improve performance	15/Jan RC
56	▷LX-WZ0001QSZZ	-	AC	DD		C	Separator pawl washer 剥離爪ワッシャー	Improve performance	15/Jan RC
57	▷LX-WZ0021QSZZ	-	AB	DJ		C	Ring スライダリング	Improve performance	15/Jan RC
	(Unit)								
901	DUNTW1221RS11		BT	MW	N	E	Fusing unit(Refer to Matrix) 定着ユニット		
	DUNTW1221RS12		BT	NE	N	E	Fusing unit(Refer to Matrix) 定着ユニット		
	DUNTW1221US13		BZ	TF	N	E	Fusing unit(Refer to Matrix) 定着ユニット		
	DUNTW1221RSZZ		BT	MW	N	E	Fusing unit(Refer to Matrix) 定着ユニット		

Matrix

No.40		ヒーターランプ (Heater lamp)			
PARTS CODE	120V	200V series	110V	100V	
RLMPU0053QSZZ				1st Lot	
RLMPU0054QSZZ			1st Lot		
RLMPU0055QSZZ	1st Lot				
RLMPU0056QSZZ		1st Lot			

No.50		高温注意ラベル (High temperature caution label)		
PARTS CODE	Americas1 Europe Australia Asia Brazil South Africa Namibia	Taiwan	Japan (日本)	
TLABH0683QSZZ			1st Lot	
TLABH0685QSZZ	1st Lot			
TLABH0686QSZZ		1st Lot		

No.901		定着ユニット (Fusing unit)			
PARTS CODE	120V	200V series	110V	100V	
DUNTW1221RS11	1st Lot				
DUNTW1221RS12		1st Lot			
DUNTW1221US13			1st Lot		
DUNTW1221RSZZ				1st Lot	

15 定着ユニット (Fusing unit)[AR-6023N,AR-6023NR,AR-X231N,AR-6020N,  
AR-6020NR,AR-6120N,AR-6023D,AR-6020D,AR-X201D,AR-6023,AR-6020,AR-X201]

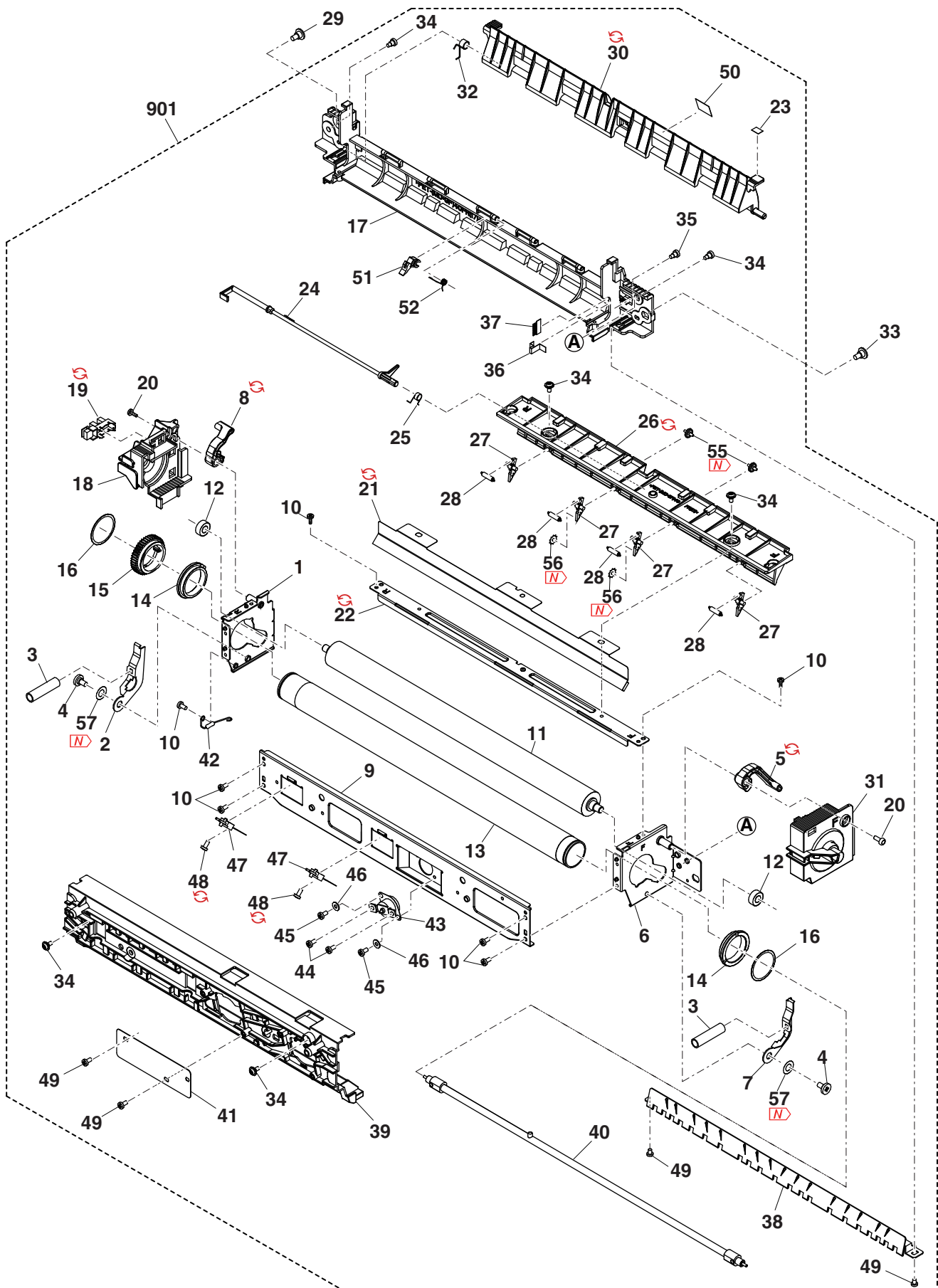

16) メイン駆動ユニット (Main drive unit)

NO.	PARTS CODE	Inter-change	PRICE Ex.	RANK Ja.	NEW MARK	PART RANK	DESCRIPTION	Reason for change	Effective time
1	CPLTM0760QS01		BA	FX	N	C	Motor drive plate Assy(Refer to Matrix)	モーター駆動板アッセン	
	CPLTM0760QS02		AZ	FX	N	C	Motor drive plate Assy(Refer to Matrix)	モーター駆動板アッセン	
	CPLTM0760QS03		AZ	FX	N	C	Motor drive plate Assy(Refer to Matrix)	モーター駆動板アッセン	
	CPLTM0760QS04	3	BA	FX	N	C	Motor drive plate Assy(Refer to Matrix)	モーター駆動板アッセン	Improve performance 14/Dec RC
	CPLTM0760QS05	3	AZ	FX	N	C	Motor drive plate Assy(Refer to Matrix)	モーター駆動板アッセン	Improve performance 14/Dec RC
2	CPLTM0760QS06	3	BA	FX		C	Motor drive plate Assy(Refer to Matrix)	モーター駆動板アッセン	Improve performance 14/Dec RC
2	XRESP50-06000		AA	DD		C	E type ring(E5)	E リンク	
	XHBS730P06000		AC	DD		C	Screw(3x6)	ビス	
3	XHBS730P06000	-	AC	DD		C	Screw(3x6)	ビス	Improve performance 14/Dec RC
4	NGERH0405QSZZ		AF	DS	N	C	Gear(69-35T)	ギヤ	
5	NGERH0407QSZ1		AE	DS		C	Gear(81-43/44T)(Refer to Matrix)	ギヤ	
	NGERH0407QSZZ		AE	DS	N	C	Gear(81-43/44T)(Refer to Matrix)	ギヤ	
6	NGERH0409QSZZ		AL	EB	N	C	Fusing drive gear(37T)(Refer to Matrix)	定着駆動ギヤ	
	NGERH0434QSZZ		AL	EB	N	C	Fusing drive gear(26T)(Refer to Matrix)	定着駆動ギヤ	
7	NGERH0408QSZZ		AD	DJ	N	C	Fusing drive front gear(52T)	定着駆動前ギヤ	
8	MSPRC0606QSZZ		AC	DD	N	C	HT ratchet spring	HT ラチェットスプリング	
9	NGERH0410QSZZ		AE	DJ	N	C	Gear(75T)(Refer to Matrix)	ギヤ	
	NGERH0435QSZZ		AD	DJ	N	C	Gear(75-44T)(Refer to Matrix)	ギヤ	
10	NGERH0414QSZZ		AE	DS	N	C	Paper feed drive gear(52-56T)(Refer to Matrix)	給紙駆動ギヤ	
	NGERH0437QSZ1		AD	DJ	N	C	Paper feed drive gear(50T)(Refer to Matrix)	給紙駆動ギヤ	
11	NGERH0415QSZZ		AE	DJ	N	C	PS drive gear(27-42T)	PS 駆動ギヤ	
12	NGERH0416QSZZ		AD	DJ	N	C	Gear(30-18T)	ギヤ	
13	NGERH0413QSZZ		AE	DS	N	C	Gear(138-28T)	ギヤ	
14	NGERH0417QSZZ		AD	DJ	N	C	Manual paper feed drive gear(35T)	手差し駆動ギヤ	
15	XRESP70-08000		AA	DD		C	E type ring(E7)	E リンク	
16	NSFTZ0205QSZZ		AK	DX		C	Drum drive shaft	ドラム駆動シャフト	
17	LPINS0329FCZZ		AB	DJ		C	Spring pin(φ2-16)	スプリングピン	
18	NBRGC0632FCZ1		AE	DS		C	Bearing(φ8-16)	軸受	
19	LPINS0327FCZZ		AC	DJ		C	Spring pin(φ2-10)	スプリングピン	
20	NCPL-0033QSZZ		AD	DD		C	Drum coupling	ドラムカップリング	
21	NGERH0406QSZZ		AF	DS		C	Drum drive gear(75T)	ドラム駆動ギヤ	
22	NGERH0412QSZZ		AD	DD	N	C	MG drive gear(20T)(Refer to Matrix)	MG 駆動ギヤ	
	NGERH0436QSZZ		AC	DD	N	C	MG drive gear(23T)(Refer to Matrix)	MG 駆動ギヤ	
23	MSPRC0262QSZ1		AC	DJ		C	MG spring	MG スプリング	
24	NCPL-0009QSZZ		AC	DJ		C	MG coupling	MG カップリング	
25	NGERH0411QSZZ		AD	DJ	N	C	Waste toner drive gear(26T)	廃トナー駆動ギヤ	
26	NPLYZ0056QSZZ		AE	DJ		C	Delivery drive gear(45-26T) [AR-6023,AR-6020,AR-X201,AR-G200]	排紙駆動ギヤ	
27	LX-WZ0460FCZZ		AC	DD		C	Flange sheet(φ6-20) [AR-6023,AR-6020,AR-X201,AR-G200]	フランジマイラー	
28	RMÖTP1045FCPZ		BC	GD		B	Paper feed motor	給紙モーター	
	RMÖTP1045FCP1	3	BF	GN	N	B	Paper feed motor	給紙モーター	Improve performance 15/Jan
29	QEARP0028QSZZ		AD	DJ		C	Drum earth plate	ドラムアース板	
30	LHLDZ0247QSZZ		AK	EB	N	C	High voltage holder	高圧ホルダー	
31	MSPRC0608QSZZ		AG	DX	N	C	GB high voltage spring	GB 高圧スプリング	
	MSPRC0608QSZ1	1	AG	DX	N	C	GB high voltage spring	GB 高圧スプリング	Productivity improvement 15/Jun
32	MSPRC0609QSZZ		AG	DX	N	C	DB high voltage spring	DB 高圧スプリング	
	MSPRC0609QSZ1	1	AG	DX	N	C	DB high voltage spring	DB 高圧スプリング	Productivity improvement 15/Jun
33	XBPS730P08KS0		AB	DD		C	Screw(3x8KS)	ビス	
34	MSPRC0607QSZZ		AD	DJ	N	C	MC high voltage spring	MC 高圧スプリング	
	MSPRC0607QSZ1	1	AD	DJ	N	C	MC high voltage spring	MC 高圧スプリング	Productivity improvement 15/Jun
35	PSPAZ1438FCPZ		AC	DJ		C	High voltage spacer	高圧スペーサー	
36	XEBS730P08000		AC	DD		C	Screw(3x6)	ビス	
37	PCOVP0219QSZZ		AD	DJ	N	C	High voltage protect cover	高圧保護カバー	
38	QEARP0027QSZZ		AC	DD	N	C	TC high voltage plate spring	TC 高圧板バネ	
40	XHBS730P06000		AC	DD		C	Screw(3x6)	ビス	
41	XBBS730P06000		AC	DD		C	Screw(3x6)	ビス	
42	PSHEZ0881QSZZ		AD	DJ		C	Harness protection sheet [AR-6023N,AR-6023NR,AR-X231N, AR-6020N,AR-6020NR,AR-6120N, AR-6023D,AR-6020D,AR-X201D,AR-6023, AR-6020,AR-X201,AR-G200]	ハーネス保護シート	
43	LX-WZ0314FCZ1		AA	DD		C	Washer [AR-6031N,AR-6031NR,AR-6131N, AR-X311N,AR-6026N,AR-6026NR]	ワッシャー	
44	CFLY-0002QS01		AW	FG	N	C	Fly wheel(Refer to Matrix)	フライホイール	
45	NFLY-0018FCZ1		AL	EB		C	Fly wheel(Refer to Matrix)	フライホイール	
46	LX-BZ2317TPZZ		AD	DJ		C	Screw(3X8)	ビス	
47	LX-WZ0023FCPZ		AA	DD		C	Paper exit roller	排出ローラー	
47	LX-WZ0314FCZ1		AA	DD		C	Washer(Refer to Matrix)	ワッシャー	
	LX-WZ0407FCZZ		AB	DD		C	Poly slider(Refer to Matrix)	ポリスライダ	
48	NBRGY0466FCZ1		AK	DX		C	Bearing(Refer to Matrix)	ベアリング	
	NBRGC0632FCZ1		AE	DS		C	Bearing(φ8-16)(Refer to Matrix)	軸受	



16) メイン駆動ユニット (Main drive unit)

NO.	PARTS CODE	Inter-change	PRICE RANK		NEW MARK	PART RANK	DESCRIPTION	Reason for change	Effective time	
			Ex.	Ja.						
49	L X - W Z 0 0 1 3 Q S Z Z	-	AB	DD		C	Poly slider(φ8.4) [AR-6031N,AR-6031NR,AR-6131N, AR-X311N,AR-6026N,AR-6026NR]	ホ°リスライダ-	Improve performance	14/Nov
	(Unit)									
901	CPL TM 0 7 6 0 R S 5 1	-	BK	HC	N	E	Main drive unit(Refer to Matrix)	メ°駆動ユニット	Change supply form	1st lot
	CPL TM 0 7 6 0 R S 5 2	-	BH	HC	N	E	Main drive unit(Refer to Matrix)	メ°駆動ユニット	Change supply form	1st lot

Matrix

No.1	モ-タ-駆動板アッセン (Motor drive plate assy)		
PARTS CODE	AR-6031N AR-6031NR AR-6131N AR-X311N AR-6026N AR-6026NR	AR-6023N AR-6023NR AR-X231N AR-6020N AR-6020NR AR-6120N AR-6023D AR-6020D AR-X201D	AR-6023 AR-6020 AR-X201 AR-G200
CPL TM 0 7 6 0 Q S 0 1			1st Lot
CPL TM 0 7 6 0 Q S 0 2		1st Lot	
CPL TM 0 7 6 0 Q S 0 3	1st Lot		
CPL TM 0 7 6 0 Q S 0 4			14/Dec RC
CPL TM 0 7 6 0 Q S 0 5		14/Dec RC	
CPL TM 0 7 6 0 Q S 0 6	14/Dec RC		

No.5	ギヤ (Gear)		
PARTS CODE	AR-6031N AR-6031NR AR-6131N AR-X311N AR-6026N AR-6026NR	AR-6023N AR-6023NR AR-X231N AR-6020N AR-6020NR AR-6120N AR-6023D AR-6020D AR-X201D AR-6023 AR-6020 AR-X201 AR-G200	
NGERH 0 4 0 7 Q S Z 1	1st Lot		
NGERH 0 4 0 7 Q S Z Z		1st Lot	

No.6	定着駆動ギヤ (Fusing drive gear)		
PARTS CODE	AR-6031N AR-6031NR AR-6131N AR-X311N AR-6026N AR-6026NR	AR-6023N AR-6023NR AR-X231N AR-6020N AR-6020NR AR-6120N AR-6023D AR-6020D AR-X201D AR-6023 AR-6020 AR-X201 AR-G200	
NGERH 0 4 0 9 Q S Z Z		1st Lot	
NGERH 0 4 3 4 Q S Z Z	1st Lot		

No.9	ギヤ (Gear)		
PARTS CODE	AR-6031N AR-6031NR AR-6131N AR-X311N AR-6026N AR-6026NR	AR-6023N AR-6023NR AR-X231N AR-6020N AR-6020NR AR-6120N AR-6023D AR-6020D AR-X201D AR-6023 AR-6020 AR-X201 AR-G200	
NGERH 0 4 1 0 Q S Z Z		1st Lot	
NGERH 0 4 3 5 Q S Z Z	1st Lot		

No.10	給紙駆動ギヤ (Paper feed drive gear)		
PARTS CODE	AR-6031N AR-6031NR AR-6131N AR-X311N AR-6026N AR-6026NR	AR-6023N AR-6023NR AR-X231N AR-6020N AR-6020NR AR-6120N AR-6023D AR-6020D AR-X201D AR-6023 AR-6020 AR-X201 AR-G200	
NGERH 0 4 1 4 Q S Z Z		1st Lot	
NGERH 0 4 3 7 Q S Z 1	1st Lot		

16) メイン駆動ユニット (Main drive unit)

No.22		MG 駆動ギア (MG drive gear)	
PARTS CODE	AR-6031N AR-6031NR AR-6131N AR-X311N AR-6026N AR-6026NR	AR-6023N AR-6023NR AR-X231N AR-6020N AR-6020NR AR-6120N AR-6023D AR-6020D AR-X201D AR-6023 AR-6020 AR-X201 AR-G200	
NGERH0412QSZZ			1st Lot
NGERH0436QSZZ	1st Lot		

No.44		フライホイール (Fly wheel)	
PARTS CODE	AR-6031N AR-6031NR AR-6131N AR-X311N AR-6026N AR-6026NR	AR-6023N AR-6023NR AR-X231N AR-6020N AR-6020NR AR-6120N AR-6023D AR-6020D AR-X201D AR-6023 AR-6020 AR-X201 AR-G200	
CFLY-0002QS01	1st Lot		
NFLY-0018FCZ1			1st Lot

No.47		ワッシャー (Washer)	
PARTS CODE	AR-6031N AR-6031NR AR-6131N AR-X311N AR-6026N AR-6026NR	AR-6023N AR-6023NR AR-X231N AR-6020N AR-6020NR AR-6120N AR-6023D AR-6020D AR-X201D AR-6023 AR-6020 AR-X201 AR-G200	
LX-WZ0314FCZ1			1st Lot
LX-WZ0407FCZZ	1st Lot		

No.48		軸受 (Bearing)	
PARTS CODE	AR-6031N AR-6031NR AR-6131N AR-X311N AR-6026N AR-6026NR	AR-6023N AR-6023NR AR-X231N AR-6020N AR-6020NR AR-6120N AR-6023D AR-6020D AR-X201D AR-6023 AR-6020 AR-X201 AR-G200	
NBRGC0632FCZ1			1st Lot
NBRGY0466FCZ1	1st Lot		

No.901		メイン駆動ユニット (Main drive unit)	
PARTS CODE	AR-6023N AR-6023NR AR-6020N AR-6020NR AR-6023D AR-6020D	AR-6023 AR-6020 AR-G200	
<input checked="" type="checkbox"/> CPLTM0760RS51			1st Lot
<input checked="" type="checkbox"/> CPLTM0760RS52	1st Lot		



16 メイン駆動ユニット (Main drive unit)

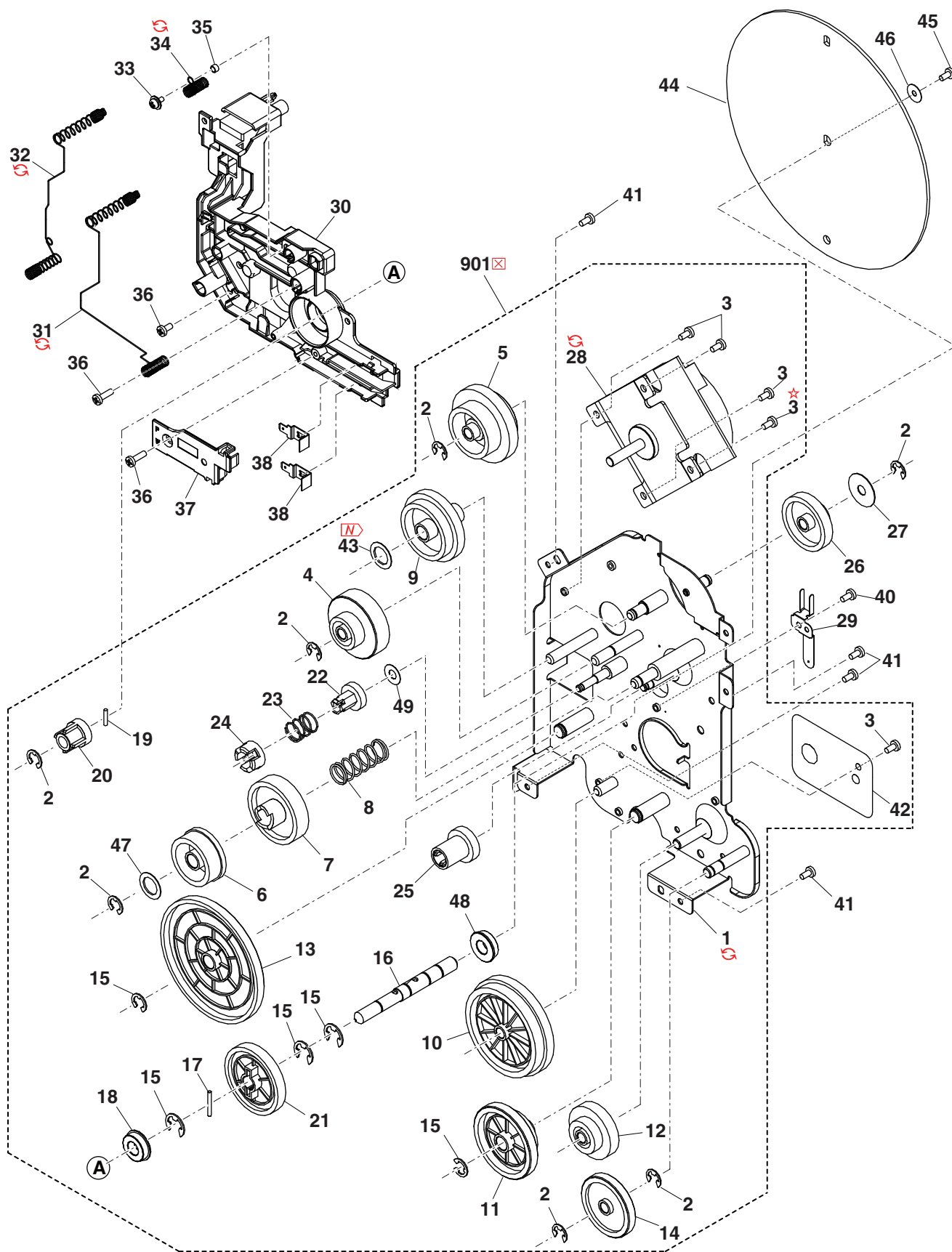

17 550 枚トレイユニット (550 paper tray unit)  
 [AR-6031N,AR-6031NR,AR-6131N,AR-X311N,AR-6026N,AR-6026NR]

NO.	PARTS CODE	Inter-change	PRICE Ex.	RANK Ja.	NEW MARK	PART RANK	DESCRIPTION	Reason for change	Effective time
1	GCASP0014QSZ2		BD	GN	N	C	550 cassette tray(Refer to Matrix)	550 ｶｯｼﾞﾄﾞﾄﾞｲ	
	GCASP0014QSZ3		BD	GN		C	550 cassette tray(Refer to Matrix)	550 ｶｯｼﾞﾄﾞﾄﾞｲ	
	GCASP0014QSZ4	3			N	C	550 cassette tray(Refer to Matrix)	550 ｶｯｼﾞﾄﾞﾄﾞｲ	Improve performance 15/Apr
2	PSHEZ0859QSZZ		AD	DJ		C	2nd cassette guide sheet	2nd ｶｯｼﾞﾄﾞｶﾞｲﾄﾞｼｰﾄ	
3	LPLTP0853QSZZ		AG	DX		C	550 cassette rear edge plate	550 ｶｯｼﾞﾄﾞ後端板	
4	LPLTM6445FCZZ		AB	DJ		C	Regulation plate	規制板ﾌﾟﾚｰﾄ	
5	PTPE-0282FCZ1		AA	DJ		C	Side plate tape R	側板ﾃｰﾌﾟ R	
6	PGiDM0254QSZZ		AN	EG		C	550 cassette guide R	550 ｶｯｼﾞﾄﾞｶﾞｲﾄﾞ R	
7	PGiDM0253QSZZ		AP	EQ		C	550 cassette guide F	550 ｶｯｼﾞﾄﾞｶﾞｲﾄﾞ F	
8	MSPRC4004FCZZ		AE	DS		C	Regulation plate lock spring	規制板ｯｯｸSP	
9	NGERH1609FCZZ		AC	DJ		B	Gear(18T)	ｷﾞｱ	
10	LPLTP0848QSZZ		AE	DJ		C	Cassette OC adjust plate	ｶｯｼﾞﾄﾞ OC 調整板	
11	XEBS730P06000		AA	DD		C	Screw(3x6)	ﾋﾟｽ	
12	NBRGP0735FCZZ		AC	DJ		C	CG bearing	CG 軸受	
13	CPLTM0785QS01		AR	EQ		C	550 cassette lift up plate	550 ｶｯｼﾞﾄﾞﾘﾌﾄｱｯﾌﾟ 板	
	CPLTM0785QS02	1			N	C	550 cassette lift up plate	550 ｶｯｼﾞﾄﾞﾘﾌﾄｱｯﾌﾟ 板	Productivity improvement 15/Apr
14	XPSSJ40-25000		AA	DD		C	Spring pin(φ4-25)	ｽﾌﾟﾘﾝｸﾞﾋﾟﾝ	
15	XRESP70-08000		AA	DD		C	E type ring(E7)	E リﾝｸﾞ	
16	LPLTM0784QSZZ		AX	FG		C	550 cassette plate	550 ｶｯｼﾞﾄﾞ板	
17	PSHEZ0274QSZZ		AC	DJ		C	Rotation plate sheet	回転板ｼｰﾄ	
18	MSPRC0624QSZ1		AD	DD		C	550 cassette earth spring	550 ｶｯｼﾞﾄﾞｱｰｽﾌﾞﾘﾝｸﾞ	
	MSPRC0624QSA1	3	AD	DD		C	550 cassette earth spring	550 ｶｯｼﾞﾄﾞｱｰｽﾌﾞﾘﾝｸﾞ	Improve performance 15/Jan RC
19	LX-BZ0833FCPZ		AC	DD		C	Rotation plate step screw	回転板用段ﾋﾟｽ	
20	GCOVA0123QSZZ		AV	FG		D	Cassette panel(Refer to Matrix)	ｶｯｼﾞﾄﾞﾊﾟﾈﾙ	
	GCOVA0126QSZZ		AU	FG		D	Cassette panel(Refer to Matrix)	ｶｯｼﾞﾄﾞﾊﾟﾈﾙ	
21	GCOV-0124QSZZ		AG	DS		C	Cassette panel sub(Refer to Matrix)	ｶｯｼﾞﾄﾞﾊﾟﾈﾙｼﾞﾌﾞ	
	GCOV-0127QSZZ		AF	DS		C	Cassette panel sub(Refer to Matrix)	ｶｯｼﾞﾄﾞﾊﾟﾈﾙｼﾞﾌﾞ	
22	JHNDP0020QSZZ		AK	EB		D	Cassette handle	ｶｯｼﾞﾄﾞ取手	
23	XEBS740P10000		AA	DD		C	Screw(4x10)	ﾋﾟｽ	
27	TCADZ0652QSZZ		AG	DS		D	Size display label	サイズ表示ﾗﾍﾞﾙ	
28	XEBS730P08000	-	AC	DD		C	Screw(3x8)	ﾋﾟｽ	Missing parts code 1st lot
	(Unit)								
901	CCASP0014RS51		BQ	LP		E	550 cassette 2nd unit (Refer to Matrix)	550 ｶｯｼﾞﾄﾞ 2nd ﾘﾝﾅｯﾄ	
	CCASP0014RS53		BM	HR		E	550 cassette 2nd unit (Refer to Matrix)	550 ｶｯｼﾞﾄﾞ 2nd ﾘﾝﾅｯﾄ	

Matrix

No.1	500 ｶｯｼﾞﾄﾞﾄﾞｲ (500 cassette tray)	
PARTS CODE	First tray	Second tray
GCASP0014QSZ2	1st Lot	
GCASP0014QSZ3		1st Lot
GCASP0014QSZ4	15/Apr	

No.20	ｶｯｼﾞﾄﾞﾊﾟﾈﾙ (Cassette panel)	
PARTS CODE	First tray	Second tray
GCOVA0123QSZZ	1st Lot	
GCOVA0126QSZZ		1st Lot

No.21	ｶｯｼﾞﾄﾞﾊﾟﾈﾙｼﾞﾌﾞ (Cassette panel sub)	
PARTS CODE	First tray	Second tray
GCOV-0124QSZZ	1st Lot	
GCOV-0127QSZZ		1st Lot

17 550 枚トレイユニット (550 paper tray unit)  
 [AR-6031N,AR-6031NR,AR-6131N,AR-X311N,AR-6026N,AR-6026NR]

No.901	550 カセット 2nd ユニット (550 cassette 2nd unit)	
PARTS CODE	First tray	Second tray
CCASP0014RS53	1st Lot	
CCASP0014RS51		1st Lot

17 550 枚トレイユニット (550 paper tray unit)  
 [AR-6031N,AR-6031NR,AR-6131N,AR-X311N,AR-6026N,AR-6026NR]

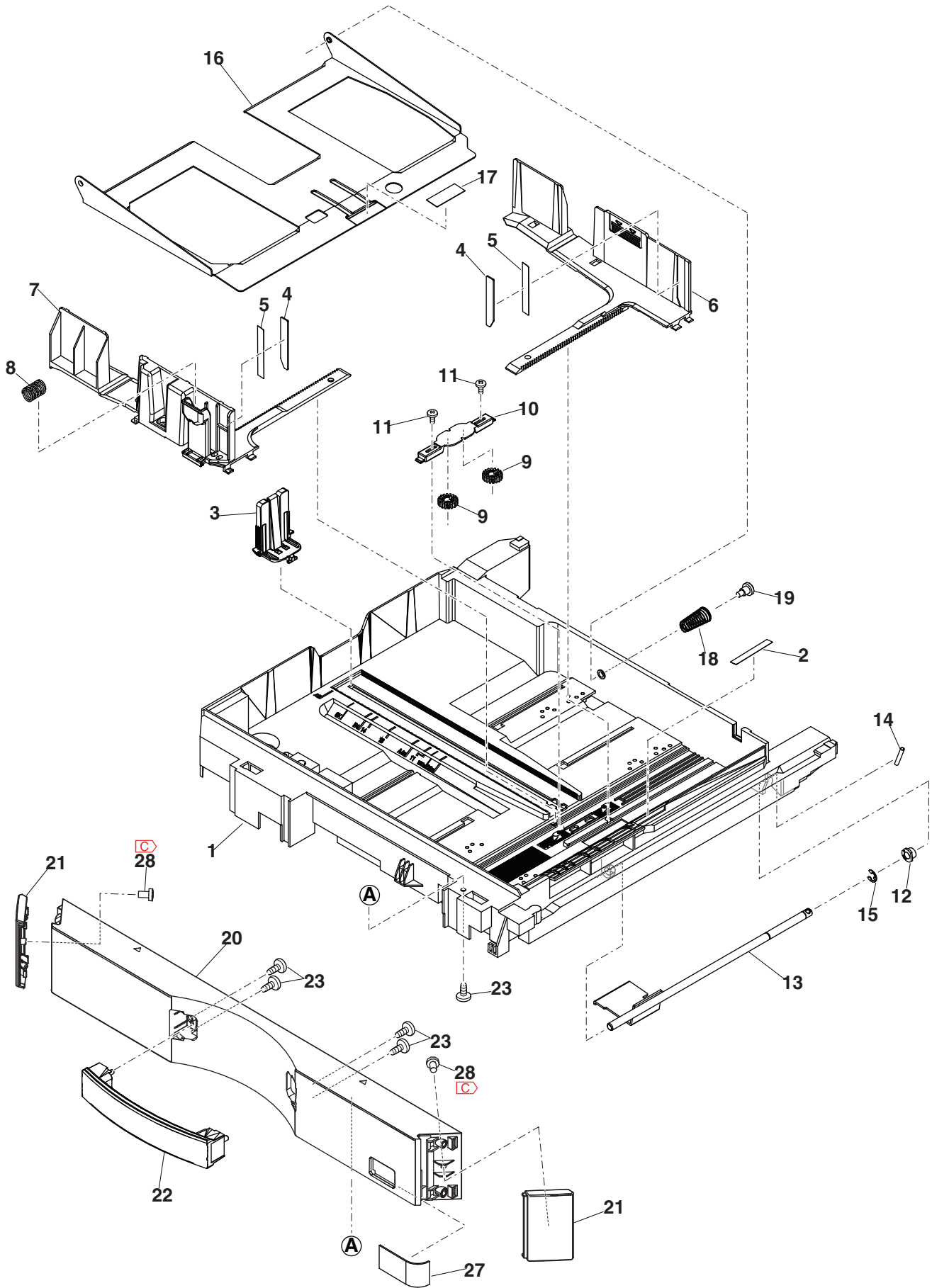

18 250枚トレイユニット (250 paper tray unit)[AR-6023N,AR-6023NR,AR-X231N,AR-6020N,AR-6020NR,AR-6120N,AR-6023D,AR-6020D,AR-X201D,AR-6023,AR-6020,AR-X201]

NO.	PARTS CODE	Inter-change	PRICE Ex.	RANK Ja.	NEW MARK	PART RANK	DESCRIPTION	Reason for change	Effective time
1	PGiDM0251QSZZ		AG	DX	N	C	Cassette guide R	カセットガイド R	
2	LPLTP0836QSZZ		AR	EQ	N	C	Cassette rotation plate	カセット回転板	
3	PSHEZ0847QSZZ		AC	DD	N	C	Rotation plate sheet	回転板シート	
4	LPLTP0837QSZZ		AF	DS	N	C	Cassette rear edge plate 250	カセット後端板 250	
5	MSPRC0618QSZZ		AD	DJ	N	C	Rotation plate spring	回転板スプリング	
6	MSPRC1145FCZZ		AA	DD		C	Stopper spring	ストップスプリング	
7	LPLTP0650QSZZ		AD	DD		C	Rotation plate lock	回転板ロック	
8	TCADZ0652QSZZ		AG	DS	N	D	Size display label	サイズ表示ラベル	
9	CPLTM0770RS51		AL	EB	N	E	Pick up plate assy	呼び込みプレートアッセン	
10	NGERH0249QSZZ		AC	DD		C	Cassette joint gear	カセット連結ギヤ	
	LPiNS0157FCZZ		AB	DD		C	Spring pin(φ3-14)	スプリングピン	
11	LPiNS0157FCZ1	-	AB	DD		C	Spring pin(φ3-14)	スプリングピン	Parts code correction 1st lot
12	MSPRC0430QSZZ		AC	DJ		C	Cassette joint gear spring	カセット連結ギヤスプリング	
14	NBRGP0037QSZZ		AC	DD		C	Bearing R	軸受 R	
15	NSFTZ0191QSZZ		AE	DS	N	C	Separate roller shaft	分離ローラー軸	
16	NROLR0245QSZZ		AH	DX	N	A	Separate roller	分離ローラー	
18	NSFTZ0190QSZZ		AM	EG	N	C	Paper feed shaft	給紙軸	
19	XPSSJ30-12000		AB	DD		C	Spring pin(φ3-12)	スプリングピン	
21	NROLR0244QSZZ		AK	DX	N	A	Paper feed roller	給紙ローラー	
22	MSPRC0619QSZZ		AB	DD	N	C	Separate pressure spring	分離加圧スプリング	
23	LHLDZ0258QSZZ		AE	DJ	N	C	Separate roller holder	分離ローラーホルダー	
24	XRESP30-06000		AA	DD		C	E type ring(E3)	E リング	
25	LFiX-0038QSZZ		AC	DD		C	Torque limiter fixer	トルクミッター押え	
26	MSPRC0506QSZZ		AF	DS		C	Torque limiter spring	トルクミッタースプリング	
27	GCOV-0124QSZZ		AG	DS	N	C	Cassette panel sub	カセットパネルサブ	
28	JHNDP0020QSZZ		AK	EB	N	D	Cassette handle	カセット取手	
29	GCOVA0123QSZZ		AV	FG	N	D	Cassette panel	カセットパネル	
30	XEBS740P10000		AA	DD		C	Screw(4×10)	ビス	
31	GCASP0013QSZ1		BA	FX	N	C	Cassette tray	カセットトレイ	
32	NGERH0193FCZZ		AB	DD		C	Manual paper feed gear	手差しギヤ	
33	PGiDM0250QSZZ		AH	DX	N	C	Cassette guide F	カセットガイド F	
34	MSPRC0572QSZ1		AC	DD		C	Regulation plate spring	規制板スプリング	
35	XEBS730P08000	-	AC	DD		C	Screw(3×8)	ビス	Missing parts code 1st lot
36	LHLDZ0287QSZZ		AD	DJ	N	C	Cassette handle fixing holder A [Japan(日本)]	カセット取手固定ホルダー A	
37	LHLDZ0288QSZZ		AD	DJ	N	C	Cassette handle fixing holder B [Japan(日本)]	カセット取手固定ホルダー B	
38	PTME-0355FCZ1		AC	DD		C	U cassette lock pawl [Japan(日本)]	U カセットロック爪	
39	LX-BZ3006SCPM		AA	DD		C	Screw(3X6) [Japan(日本)]	ビス	
40	NSFTZ0211QSZZ		AL	EB	N	C	Cassette lock shaft 500 [Japan(日本)]	カセットロックシャフト 500	
	NSFTZ0210QSZZ	-	AM	EG	N	C	Cassette lock shaft 250 [Japan(日本)]	カセットロックシャフト 250	Parts code correction 1st lot
41	LPiNS0327FCZZ		AC	DJ		C	Spring pin(2X10) [Japan(日本)]	スプリングピン	
42	MARMP0473FCZZ		AC	DJ		C	U cassette release arm [Japan(日本)]	U カセット解除アーム	
43	MSPRC0666QSZZ		AD	DJ	N	C	Cassette lock pawl spring [Japan(日本)]	カセットロック爪スプリング	
44	NBRGP0696FCZZ		AE	DJ		C	Belt idle bearing [Japan(日本)]	ベルトアイドル軸受	
	XRESP50-06000		AA	DD		C	E ring [Japan(日本)]	E リング	
45	PMLT-0276QSZZ	-			N	C	Cassette rear edge cushion [Americas 1,Asia 3,Brazil]	カセット後端パッド	Productivity improvement 14/Dec
	MSPRC0152QSZZ	-	AB	DJ		C	Cassette ejection spring D [Japan(日本)]	カセット押し出しスプリング D	Missing parts code 1st lot
	(Unit)								
	CCASP0013RS51		BH	HC	N	E	Cassette unit(Refer to Matrix)	カセットユニット	
901	CCASP0013RS52	-	BH	GX	N	E	Cassette unit(Refer to Matrix)	カセットユニット	Parts code correction 1st lot
	CCASP0013RS53		BL	HR	N	E	Cassette unit(Refer to Matrix)	カセットユニット	
	CCASP0013RS54	-	EX	LX	N	E	Cassette unit(Refer to Matrix)	カセットユニット	Parts code correction 1st lot

18 250 枚トレイユニット (250 paper tray unit)[AR-6023N,AR-6023NR,AR-X231N,AR-6020N, AR-6020NR,AR-6120N,AR-6023D,AR-6020D,AR-X201D,AR-6023,AR-6020,AR-X201]

**Matrix**

No.901		カセットユニット (Cassette unit)		
PARTS CODE	Americas1 Asia3 Brazil	Europe Australia Asia1 Asia2 Asia4 Asia6 Asia10 SouthAfrica Namibia Taiwan	Japan (日本)	
CCASP0013RS51	Correction	Correction		
CCASP0013RS52	Correction	1st Lot		
CCASP0013RS53				1st Lot
CCASP0013RS54	1st Lot			

18 250 枚トレイユニット (250 paper tray unit)[AR-6023N,AR-6023NR,AR-X231N,AR-6020N,  
AR-6020NR,AR-6120N,AR-6023D,AR-6020D,AR-X201D,AR-6023,AR-6020,AR-X201]

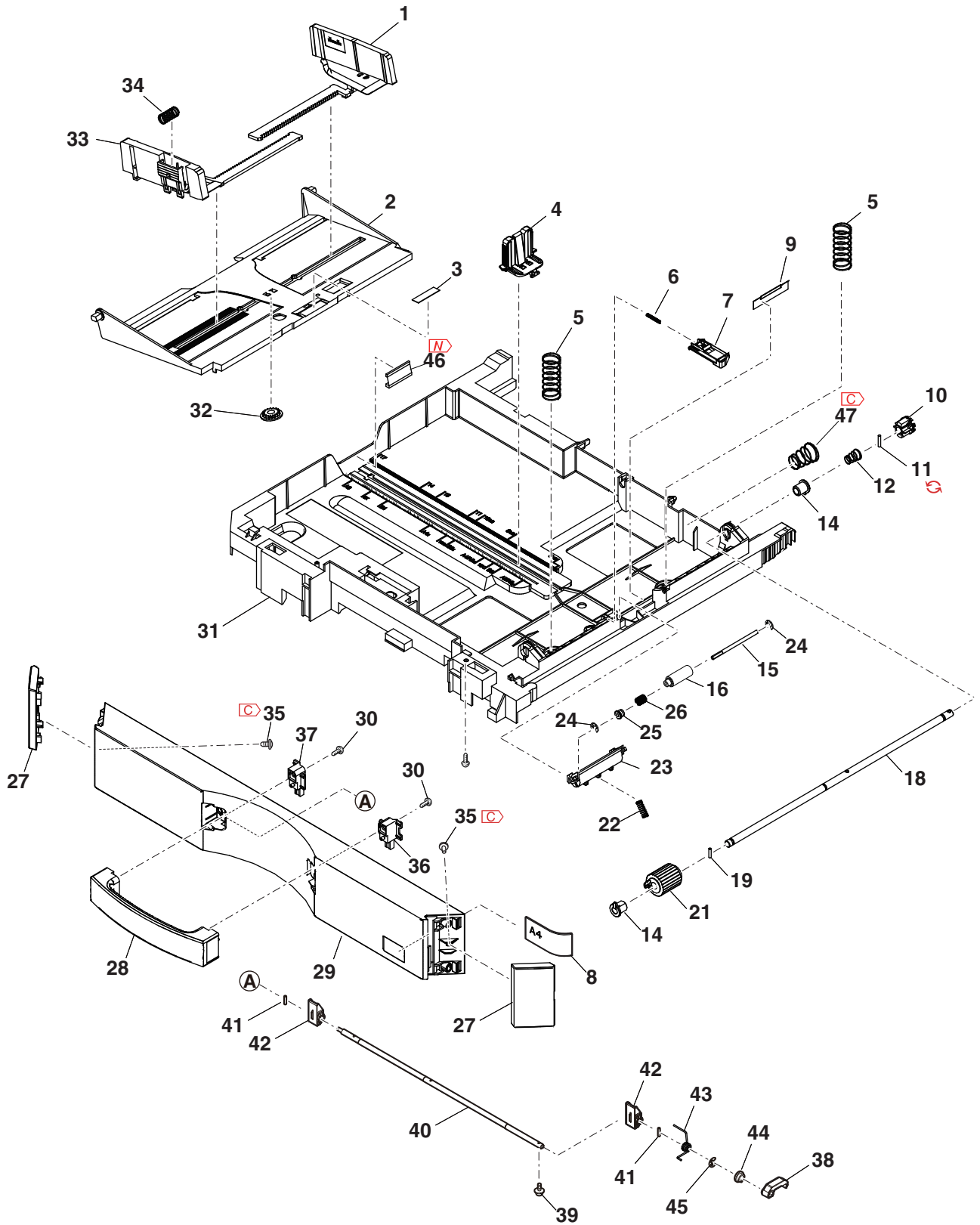

19 給紙ユニット (Paper Feed Unit)

[AR-6031N,AR-6031NR,AR-6131N,AR-X311N,AR-6026N,AR-6026NR]

NO.	PARTS CODE	Inter-change	PRICE RANK		NEW MARK	PART RANK	DESCRIPTION	Reason for change	Effective time
			Ex.	Ja.					
1	MLEVP1153FCZZ		AE	DJ		C	Desk PE actuator	デスク PE アクチエーター	
	VHPSG2A141+-1		AF	DS		B	Photo sensor(SG2A141)	フォトセンサー	
2	VHPSG2A241+-1	1			N	B	Photo sensor(SG2A241)	フォトセンサー	Productivity improvement 15/Jun
3	XRESP50-06000		AA	DD		C	E type ring(E5)	E リング	
4	NBRGM0968FCZZ		AC	DD		C	Mirror bearing N	ミラ-軸受 N	
5	MSPRC3893FCZ1		AC	DJ		C	Pick up lever spring	ピックアップレバ- SP	
6	MLEVP0189QSZZ		AD	DJ		C	2nd paper feed release lever	2nd 給紙解除レバ-	
	LFRM-0170QSZ1		AT	EZ	N	C	2nd paper feed frame	2nd 給紙フレーム	
7	LFRM-0170QSZ2	3			N	C	2nd paper feed frame	2nd 給紙フレーム	Improve performance 15/Apr
8	NSFTZ0204QSZ1		AK	DX	N	C	Paper feed roller shaft	給紙ローラ-軸	
9	LHLDZ0291QSZZ		AG	DX		C	550 cassette separate holder	550 カセット分離ホルダ-	
10	XRESP40-06000		AA	DD		C	E type ring(E4)	E リング	
11	MSPRC3956FCZ3		AH	DX		C	Desk paper feed separation spring	デスク給紙分離 SP	
12	XEBS740P10000		AA	DD		C	Screw(4x10)	ビス	
13	XEBS730P08000		AC	DD		C	Screw(3x8)	ビス	
14	LPLTM0928QSZ1		AG	DS	N	C	Right rail upper paper guide reinforce plate	右レール上パ-パ-カト補強板	
15	PGiDM0286QSZ1		AN	EG	N	C	Right rail upper paper guide	右レール上パ-パ-カト	
16	NSFTZ0194QSZ1		AH	DX		C	550 cassette separate roller shaft	550 カセット分離ローラ-軸	
17	LPiNS0089FCZZ		AA	DD		C	Spring pin	スプリングピン	
18	PCLC-0325FCZZ		AP	EQ		B	Separate torque limiter	分離トルクミッター	
19	NROLR1791FCZZ		AH	DX		A	Separate roller FT	分離ローラ- FT	
20	LHLDZ1990FCZZ		AD	DJ		C	Pick up holder	呼込ホルダ-	
21	LPiNS0327FCZZ		AC	DJ		C	Spring pin(φ2-10)	スプリングピン	
22	NGERH1952FCZZ		AC	DJ		C	Gear(22T)	ギヤ	
	NROLR1790FCZZ		AP	EQ		A	Paper feed roller	給紙ローラ-	
23	NROLR1790FCZ1	3	AS	EQ		A	Paper feed roller	給紙ローラ-	Improve performance 14/Dec
24	NGERH1951FCZZ		AH	DX		C	Pick up joint gear(21T)	呼込連結ギヤ	
25	NROLR1792FCZZ		AK	EB		A	Pickup roller	呼込ローラ-	
26	MSPRC0622QSZZ		AC	DD		C	2nd paper feed holder spring	2nd 給紙ホルダ-スプリング	
27	LHLDZ0261QSZZ		AK	DX		C	2nd paper feed holder	2nd 給紙ホルダ-	
29	PMLT-0275QSZZ		AD	DD		C	Paper feed damper cushion	給紙消音パ-	
	(Unit)								
901	CFRM-0170RS51		BF	GN		E	Paper feed frame unit	給紙フレームユニット	





20 2nd 給紙ユニット (2nd paper Feed Unit)  
 [AR-6031N,AR-6031NR,AR-6131N,AR-X311N,AR-6026N,AR-6026NR]

NO.	PARTS CODE	Inter-change	PRICE Ex.	RANK Ja.	NEW MARK	PART RANK	DESCRIPTION	Reason for change	Effective time
1	VHPGP2A240L-1		AP	EQ		B	Reflection sensor(GP2A240L)	反射型センサー	
2	VHPLG248NL1-1		AF	DS		B	Photo sensor(LG248NL1)	フォトセンサー	
3	LFRM-0169QSZZ		AY	FQ		C	2nd paper feed frame	2nd 給紙フレーム	
4	LHLDZ0262QSZZ		AD	DJ		C	2nd transport sensor holder	2nd 搬送センサーホルダ	
5	XEBS730P08000		AC	DD		C	Screw(3x8)	ビス	
6	MLEVP1153FCZZ		AE	DJ		C	Desk PE actuator	デスクPEアクチエーター	
	NRÖLR0247QSZZ		AP	EQ		A	2nd transport roller	2nd 搬送ローラー	
7	NRÖLR0247QSZ1	3	AP	EQ		A	2nd transport roller	2nd 搬送ローラー	Improve performance 14/Dec RC
8	LPLTM0787QSZZ		AG	DX		C	Clutch earth plate	クラッチアース板	
9	LHLDZ0261QSZZ		AK	DX		C	2nd paper feed holder	2nd 給紙ホルダ	
10	NRÖLR1792FCZZ		AK	EB		A	Pickup roller FT	呼込ローラー FT	
11	NSFTZ0195QSZZ		AK	DX		C	2nd paper feed shaft	2nd 給紙シャフト	
12	MSPRC0622QSZZ		AC	DD		C	2nd paper feed holder spring	2nd 給紙ホルダ スプリング	
14	LHLDZ1990FCZZ		AD	DJ		C	Pick up holder	呼込ホルダ	
15	NGERH1951FCZZ		AH	DX		C	Pick up joint gear(21T)	呼込連結ギヤ	
16	NGERH1952FCZZ		AC	DJ		C	Gear(22T)	22TギヤMO8	
	NRÖLR1790FCZZ		AP	EQ		A	Paper feed roller FT	給紙ローラー FT	
17	NRÖLR1790FCZ1	3	AS	EQ		A	Paper feed roller FT	給紙ローラー FT	Improve performance 14/Dec RC
18	LPINS0327FCZZ		AC	DJ		C	Spring pin(φ2-10)	スプリングピン	
19	MLEVP0189QSZZ		AD	DJ		C	2nd paper feed release lever	2nd 給紙解除レバー	
20	MSPRC3893FCZ1		AC	DJ		C	Pick up lever spring	ピックアップレバーSP	
21	NBRGM0968FCZZ		AC	DD		C	Mirror bearing N	ミラー軸受 N	
22	XRESP50-06000		AA	DD		C	E type ring(E5)	Eリング	
23	NGERH0428QSZZ		AD	DJ		C	Clutch gear(28T)	クラッチギヤ	
24	NGERH0427QSZZ		AD	DJ		C	2nd gear(27T/22T)	2nd ギヤ	
25	NGERH0426QSZZ		AD	DJ		C	Clutch gear(46T)	クラッチギヤ	
26	PCLC-0020QSZZ		AX	FG		B	Transport clutch	搬送クラッチ	
27	PCLC-0041QSZZ		AT	EZ		B	2nd paper feed clutch	2nd 給紙クラッチ	
28	XRESP40-06000		AA	DD		C	E type ring(E4)	Eリング	
29	NSFTZ0194QSZZ		AH	DX		C	550 cassette separate roller shaft	550 カセット分離ローラー軸	
30	LPINS0089FCZZ		AA	DD		C	Spring pin	スプリングピン	
31	PCLC-0325FCZZ		AP	EQ		B	Separate torque limiter	分離トルクミッター	
32	NRÖLR1791FCZZ		AH	DX		A	Separate roller FT	分離ローラー FT	
33	LHLDZ0260QSZZ		AG	DS		C	550 cassette separate holder	550 カセット分離ホルダ	
34	LPLTM0844QSZZ		AM	EG		C	2nd separate holder plate	2nd 分離ホルダ板	
35	MSPRC3956FCZ3		AH	DX		C	Desk paper feed separation spring	デスク給紙分離SP	
36	XBBS740P08000		AA	DD		C	Screw(4x8)	ビス	
37	XEBS740P12000		AA	DD		C	Screw(4x12)	ビス	
40	NBRGP0873FCZZ		AC	DJ		C	Transfer roller bearing	転写ローラー軸受	
41	XRESP30-06000		AA	DD		C	E type ring(E3)	Eリング	
42	MARMP0087QSZZ		AD	DJ		C	2nd joint arm	2ND 連結アーム	
43	NGERH0097QSZZ		AF	DS		C	2nd joint gear(56T)	2ND 連結ギヤ	
44	MSPRT0203QSZZ		AC	DJ		C	2nd joint arm spring	2ND 連結アームSP	
45	PCLR-0485FCZZ		AD	DJ		C	U-turn collar	Uターンコリ	
	(Unit)								
901	CFRM-0169RS51		BN	HV	N	C	Paper feed frame unit	給紙フレームユニット	

20 2nd 給紙ユニット (2nd paper Feed Unit)  
 [AR-6031N,AR-6031NR,AR-6131N,AR-X311N,AR-6026N,AR-6026NR]

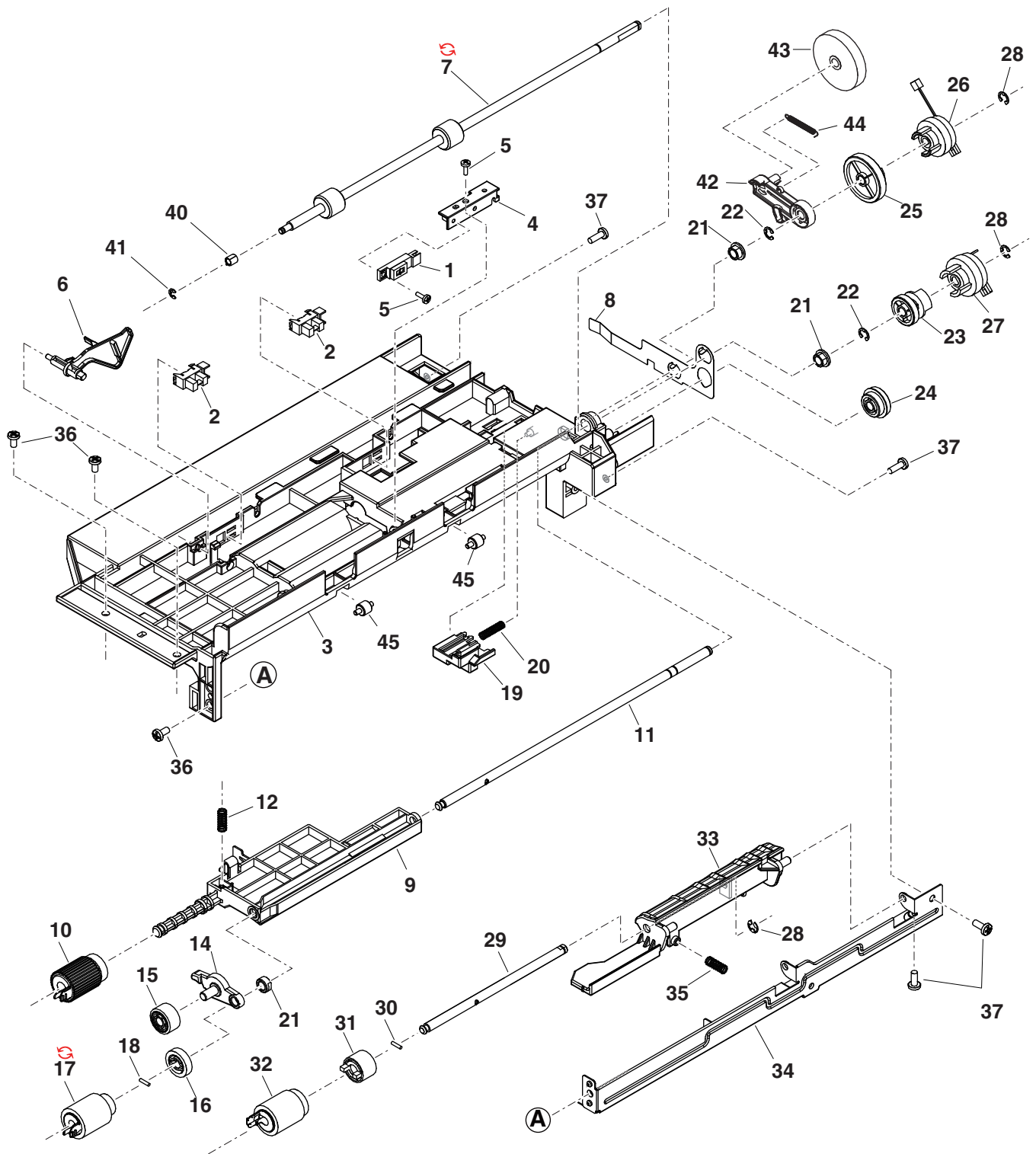

21 2nd Unit (2nd unit)

[AR-6031N,AR-6031NR,AR-6131N,AR-X311N,AR-6026N,AR-6026NR]

NO.	PARTS CODE	Inter-change	PRICE Ex.	RANK Ja.	NEW MARK	PART RANK	DESCRIPTION	Reason for change	Effective time
1	LFRM-0168QSZZ		AY	FQ		C	2nd right rear frame 2nd 右後フレーム		
	LFRM-0168QSZ1	3			N	C	2nd right rear frame 2nd 右後フレーム	Improve performance	15/Mar RC
2	MLOKZ0011FCZ1		AC	DJ		C	Cassette lock カセットロック		
3	XEBS740P12000		AA	DD		C	Screw(4x12) ビス		
4	LPLTM0841QSZZ		AU	EZ		C	2nd rear reinforce plate 2nd 後補強板		
5	MSPRC0437QSZZ		AC	DJ		C	Cassette earth spring カセットアースリンク		
6	CCOVP1607FC458		AX	FG		E	Lift up unit リフトアップユニット		
7	GGAD-0002QSZZ		AE	DS		C	Edge guard lower エッジガード下		
8	PSHEZ0884QSZZ		AD	DD		C	2nd PWB protect sheet 2nd 基板保護シート		
9	LFRM-0166QSZ1		BA	FX		C	2nd left frame 2nd 左フレーム		
	LFRM-0166QSZ2	3			N	C	2nd left frame 2nd 左フレーム	Improve performance	15/Mar RC
10	LPLTM0842QSZZ		AP	EQ		C	2nd front upper reinforce plate 2nd 前上補強板		
11	LFRM-0167QSZZ		AS	EZ		C	2nd right front frame 2nd 右前フレーム		
	LFRM-0167QSZ1	3			N	C	2nd right front frame 2nd 右前フレーム	Improve performance	
12	LPLTM0845QSZZ		AP	EQ		C	2nd right rail plate 2nd 右レール板		
13	NCPL-0052FCZ1		AH	DX		B	Lift coupling リフトカップリング		
14	MSPRC2907FCZ1		AC	DJ		C	Lift up spring リフトアップスプリング		
15	LPLTM0843QSZZ		AM	EG		C	2nd front lower reinforce plate 2nd 前下補強板		
16	NKOM-0005QSZZ		AC	DJ		C	Cassette guide collar カセットガイドコリ		
17	NSFTZ0137QSZ1		AF	DS		C	Cassette collar shaft カセットコリ軸		
18	XBPS730P08KS0		AB	DD		C	Screw(3x8KS) ビス		
19	XBBS730P06000		AC	DD		C	Screw(3x6) ビス		
20	PCLR-0519FCZZ		AE	DS		C	Cassette rail collar カセットレールコリ		
21	LX-BZ0926FCP1		AC	DD		C	Step screw 段ビス		
22	MLOKZ0009QSZZ		AC	DD	N	C	Transport paper guide lock 搬送ペーパーガイドロック		
23	MSPRC0378QSZ1		AB	DJ		C	Lock spring ロックスプリング		
24	XEPS730P08X00		AA	DD		C	Screw(3x8X) ビス		
25	GLEGG0008QSZZ		AC	DD		C	Rubber foot ゴム足		
26	XHBS730P35000		AK	DX		C	Screw(3x35) ビス		
27	XHBS730P08000		AB	DD		C	Screw(3x8) ビス		
28	QSW-B0017QSZZ		AF	DS		B	Waste toner lock detect switch(D2X-G) 廃トナーロック検知スイッチ		
29	LPLTM0504QSZZ		AC	DJ		C	Joint plate S 接合板 S		
30	XBBS730P08000		AA	DD		C	Screw(3x8) ビス		
31	MSPRC0657QSZZ		AC	DD		C	2nd rail guide PG push out spring 2ND 可動 PG 圧出 SP		
32	LPLTM0786QSZZ		AF	DS		C	2nd lift up fixing plate 2nd リフトアップ 取付板		
33	CPWBF0228QSE4		AZ	FQ		E	2nd cassette interface PWB 2nd カセット中継基板		
	CPWBF0228QSE6	1	AZ	FQ		E	2nd cassette interface PWB 2nd カセット中継基板	Improve performance	15/Jun
34	GCOVA0130QSZZ		AV	FG		D	2nd rear cover 2nd 後カバー		
35	MARMP0015QSZZ		AD	DJ		C	1st door arm 1st ドアアーム		
36	MSPRT0433QSZZ		AC	DJ		C	Right lower door pressure spring 右下ドア加圧スプリング		
37	NSFTZ0201QSZZ		AE	DS		C	2nd Transport paper guide shaft 2nd 搬送ペーパーガイドシャフト		
38	NRÖLP1060FCZZ		AF	DS		C	U-turn roller Uターンローラー		
39	PGiDM0273QSZZ		AN	EG		C	2nd rail guide paper guide 2nd レールガイドペーパーガイド		
40	PGiDM0255QSZ1		AQ	EQ		C	2nd transport paper guide 2nd 搬送ペーパーガイド		
41	GCOVA0128QSZ1		AQ	EQ		D	2nd right door 2nd 右ドア		
42	GCOVA0129QSZ1		AG	DX		D	2nd left cover 2nd 左カバー		
43	LSUPP0083FCZZ		AB	DJ		C	PWB supporter(LCBS-3) 基板 supporter		
44	XHBS740P08000		AA	DD		C	Screw(4x8) ビス		
52	XBBS740P08000		AA	DD		C	Screw(4x8) ビス		

21 2ndユニット (2nd unit)  
 [AR-6031N,AR-6031NR,AR-6131N,AR-X311N,AR-6026N,AR-6026NR]

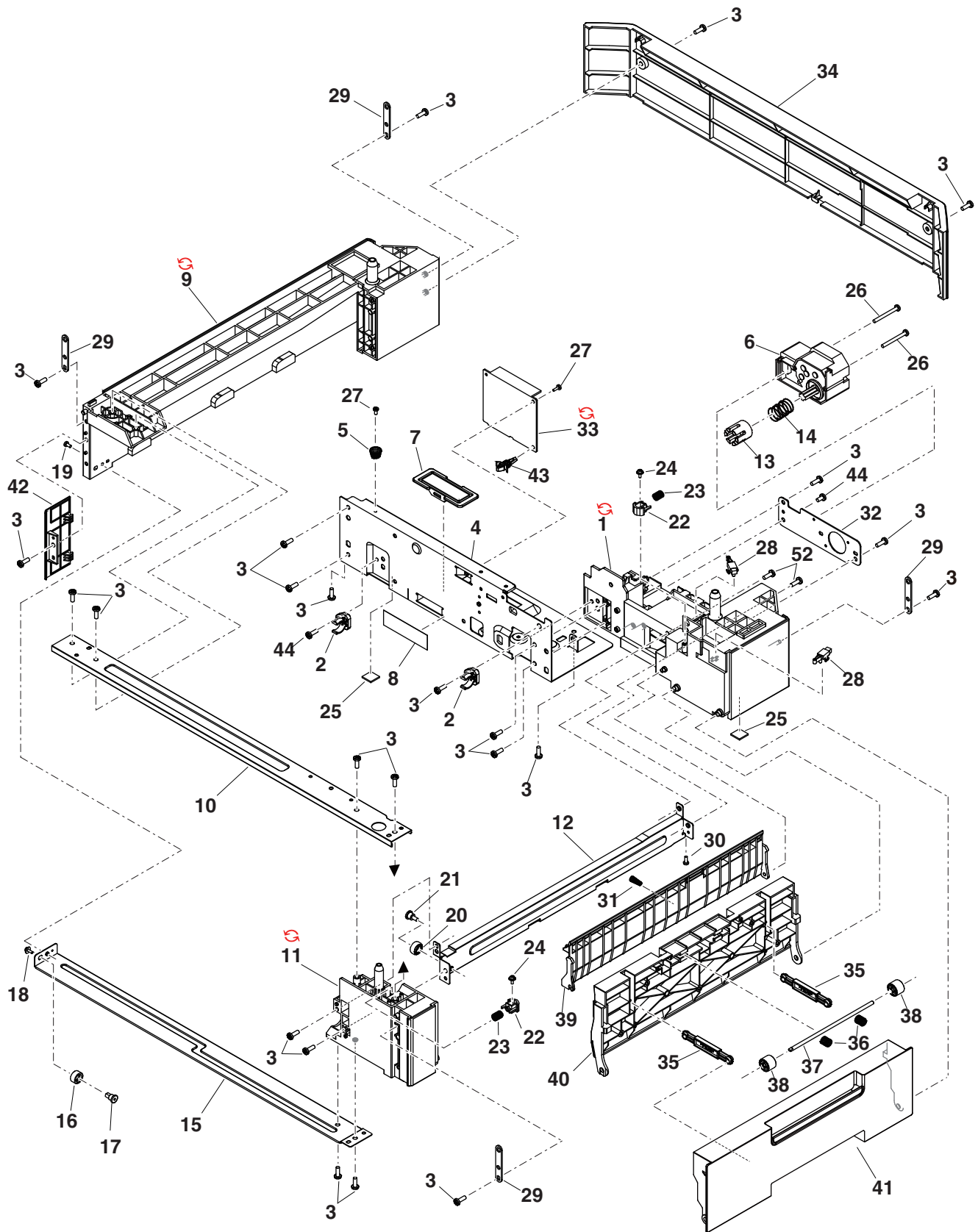

22 手差しマルチユニット (MF unit)

NO.	PARTS CODE	Inter-change	PRICE Ex.	RANK Ja.	NEW MARK	PART RANK	DESCRIPTION	Reason for change	Effective time
1	PGiDM0274QSZZ		AL	EB	N	C	Manual paper feed guide paper guide	手差しがイトハノパカト	
	PGiDM0274QSZ1	3	AL	EB	N	C	Manual paper feed guide paper guide	手差しがイトハノパカト	Improve performance 14/Nov RC
2	PGiDM0271QSZZ		AL	EB	N	C	Manual paper feed transport guide	手差し搬送がイト	
3	NGERH0443QSZZ		AD	DJ	N	C	Manual paper feed gear(37T)	手差しギヤ	
4	NBRGP0696FCZZ		AE	DJ		C	Bearing	軸受	
5	MSPRC0646QSZZ		AD	DJ	N	C	Manual paper feed earth spring	手差しアースリング	
	MSPRC0646QSAZ	3	AD	DJ		C	Manual paper feed earth spring	手差しアースリング	Improve performance 14/Feb RC
6	NBRGC0651FCZZ		AD	DJ		C	Bearing	軸受	
7	PCLC-0373FCZ1		AP	EQ		B	Clutch N(2.5KG)(Refer to Matrix)	クラッチ N	
	PCLC-0040QSZ1		AR	EQ		B	Clutch N(3.5KG)(Refer to Matrix)	クラッチ N	
8	LPLTP0852QSZZ		AQ	EQ	N	C	Rotation plate	回転板	
	LPLTP0852QSZ1	1	AQ	EQ	N	C	Rotation plate	回転板	Improve performance 14/Nov RC
9	PSHEZ0847QSZZ		AC	DD	N	C	Rotation plate sheet	回転板シート	
10	LPLTP0792QSZZ		AC	DD	N	C	Rotation plate lock ST fixing plate	回転板ロック ST 押え板	
11	MLOKZ0008QSZZ		AE	DS		C	MF rotation plate lock	MF 回転板ロック	
12	PGiDM0258QSZZ		AF	DS	N	C	MF regulation rack R	MF 規制ラック R	
	PGiDM0258QSZ1	3	AF	DS	N	C	MF regulation rack R	MF 規制ラック R	Improve performance 14/SEP RC
13	NGERH0021QSZZ		AD	DJ		C	Manual paper feed gear	手差しギヤ	
14	PGiDM0259QSZZ		AF	DS	N	C	MF regulation rack L	MF 規制ラック L	
	PGiDM0259QSZ1	3	AF	DS	N	C	MF regulation rack L	MF 規制ラック L	Improve performance 14/SEP RC
15	MSPRC0544QSZZ		AC	DD		C	MF rotation plate lock spring	MF 回転板ロック スプリング	
16	XEBS730P05000		AA	DD		C	Screw(3x5)	ビス	
17	XWHS730-08100		AA	DD		C	Washer	ワッシャ	
18	MARMP0005QSE1		AD	DJ		C	Tray arm	トレイアーム	
19	LSOU-0078QSZ1		AG	DX	N	D	MF extension tray	MF 延長トレイ	
20	LSOU-0075QSZZ		AU	EZ	N	D	MF tray	MF トレー	
21	MSPRC0616QSZZ		AC	DD	N	C	MF pick up spring	MF 呼び込み スプリング	
23	PCOVP0220QSZZ		AG	DX	N	D	Service cover cover	サービスカバー	
24	PCOVP0227QSZZ		AV	FG	N	D	Manual paper feed cover	手差しカバー	
25	NR0LR0251QSZZ		AN	EG		A	Paper feeding roller	給紙ローラー	
26	LPinS0327FCZZ		AC	DJ		C	Spring pin(φ2-10)	スプリングピン	
27	NCPL-0081FCZZ		AH	DX		B	One way coupling	ワンウェイカップリング	
28	XRESP50-06000		AA	DD		C	E type ring(E5)	E リング	
29	XHBS730P06000		AC	DD		C	Screw(3x6)	ビス	
30	NGERH0440QSZZ		AC	DD	N	C	Gear(27T)	ギヤ	
31	NSFTZ0189QSZZ		AH	DX	N	C	Paper feed shaft	給紙シャフト	
32	XEBS730P08000		AC	DD		C	Screw(3x8)	ビス	
33	LHLDZ0252QSZZ		AD	DJ	N	C	SUS plate holder	SUS 板ホルダー	
34	LPLTM0685QSZZ		AC	DD		C	Pick up plate	呼び込みプレート	
35	NSFTZ0154QSZZ		AE	DS		C	Follower roller shaft	従動ローラー軸	
	XRESP30-04000		AA	DD		C	E ring(E3)	E リング	
	XRESP30-06000	3	AA	DD		C	E type ring(E3)	E リング	Improve performance 14/DEC RC
37	LFIX-0038QSZZ		AC	DD		C	Torque limiter fixer	トルクリミッター押え	
38	MSPRC0506QSZZ		AF	DS		C	MF torque limiter spring	MF トルクリミッター スプリング	
39	NR0LR0213QSAZ		AK	DX		A	Separation roller	分離ローラー	
40	LHLDZ0201QSZZ		AE	DJ		C	MF separate roller holder	MF 分離ローラーホルダー	
41	LFRM-0153QSZZ		AQ	EQ	N	C	Manual paper feed frame	手差しフレーム	
42	VHPSG2A141+-1		AF	DS		B	Photo sensor(SG2A141)	フォトセンサー	
	VHPSG2A241+-1	1			N	B	Photo sensor(SG2A241)	フォトセンサー	Productivity improvement 15/Jun
43	MSPRD0546QSZZ		AC	DD		C	MF paper existence detect actuator spring	MF 用紙有無検知 アクチュエーター スプリング	
44	MLEVP0184QSZZ		AD	DJ	N	C	Paper existence detect lever	紙有無検知レバー	
45	NSFTZ0179QSZZ		AD	DJ		C	MF gear fulcrum shaft	MF ギヤ支点軸	
46	MSPRC0593QSZ1		AC	DD		C	MF drive brake spring	MF 駆動ブレーキ スプリング	
	MSPRC0672QSZZ	3	AF	DS	N	C	MF drive brake spring	MF 駆動ブレーキ スプリング	Improve performance 15/Jan
47	NGERH0362QSZZ		AD	DJ		C	MF gear	MF ギヤ	
50	NGERH0423QSZZ		AC	DD	N	C	Separate gear(18T)	分離ギヤ	
51	LHLDZ0228QSZZ		AD	DJ		C	MF lock holder	MF ロックホルダー	
52	MSPRD0647QSZZ		AC	DD	N	C	MF drive joint spring	MF 駆動連結 スプリング	
53	NSFTZ0188QSZZ		AE	DS	N	C	Pressure release support shaft	圧解除補助シャフト	
54	MSPRD0629QSZZ		AC	DD	N	C	Front frame return spring L	前フレーム復帰 スプリング L	
55	MSPRC0542QSZZ		AC	DD		C	MF separate pressure spring	MF 分離加圧 スプリング	
	MSPRC0670QSZZ	3	AC	DD	N	C	MF separate pressure spring	MF 分離加圧 スプリング	Improve performance 15/Jan RC
57	PSHEZ0788QSZZ		AD	DD		C	MF Paper feed front separate sheet	MF 給紙前カバーシート	
58	PTPE-0076QSZZ		AC	DD		C	Pick up plate sheet	呼び込みプレートシート	
59	LSTPP0016QSZZ		AC	DJ		C	Stopper(E5)	ストッパー	
60	PSHEZ0883QSZZ	-	AD	DJ	N	C	Manual paper feed guide sheet	手差しガイドマラー	Specification change 1st lot



22 手差しマルチユニット (MF unit)

NO.	PARTS CODE	Inter-change	PRICE RANK		NEW MARK	PART RANK	DESCRIPTION	Reason for change	Effective time
			Ex.	Ja.					
61	XEBS730P08000		AC	DD		C	Screw(3×8) ビス		
62	XEBS740P08000		AA	DD		C	Screw(4×8) ビス		
63	XRESP40-06000		AA	DD		C	E type ring(E4) Eリング		
64	T LABH1005QSZZ		BB	GD	N	D	MF size label A [Japan(日本)] MFサイズラベルA		
65	T LABH1006QSZZ		BA	FX	N	D	MF size label B [Japan(日本)] MFサイズラベルB		
66	PSHEZ0916QSZZ		AC	DD		C	MF guide sheet A MFガイドシートA		
67	PSHEZ0917QSZZ		AC	DD		C	MF guide sheet A MFガイドシートA		
68	PSHEZ0930QSZZ	-	AE	DJ	N	C	Manual paper feed guide sheet 手差しガイドシート	Improve performance	15/Jan RC
501	CFRM-0153RS71		BF	GN	N	E	Manual paper feed paper feed unit (Refer to Matrix) 手差し給紙ユニット		
	CFRM-0153RS73	3	BF	GN	N	E	Manual paper feed paper feed unit (Refer to Matrix) 手差し給紙ユニット	Improve performance	15/Jan RC
	CFRM-0153RS74		BK	HC	N	E	Manual paper feed paper feed unit (Refer to Matrix) 手差し給紙ユニット		
502	CSOU-0075RS51		BD	GN	N	E	Manual paper feed paper feed unit 手差しトレイユニット		

Matrix

No.7	クラッチ N(Clutch N)	
PARTS CODE	Americas1 Europe Australia Asia Class B	Japan(日本)
PCLC-0040QSZ1		1st Lot
PCLC-0373FCZ1	1st Lot	

No.501	手差し給紙ユニット (Manual paper feed paper feed unit)	
PARTS CODE	Americas1 Europe Australia Asia Class B	Japan(日本)
CFRM-0153RS71	1st Lot	
CFRM-0153RS73	15/Jan RC	
CFRM-0153RS74		1st Lot

22 手差しマルチユニット (MF unit)

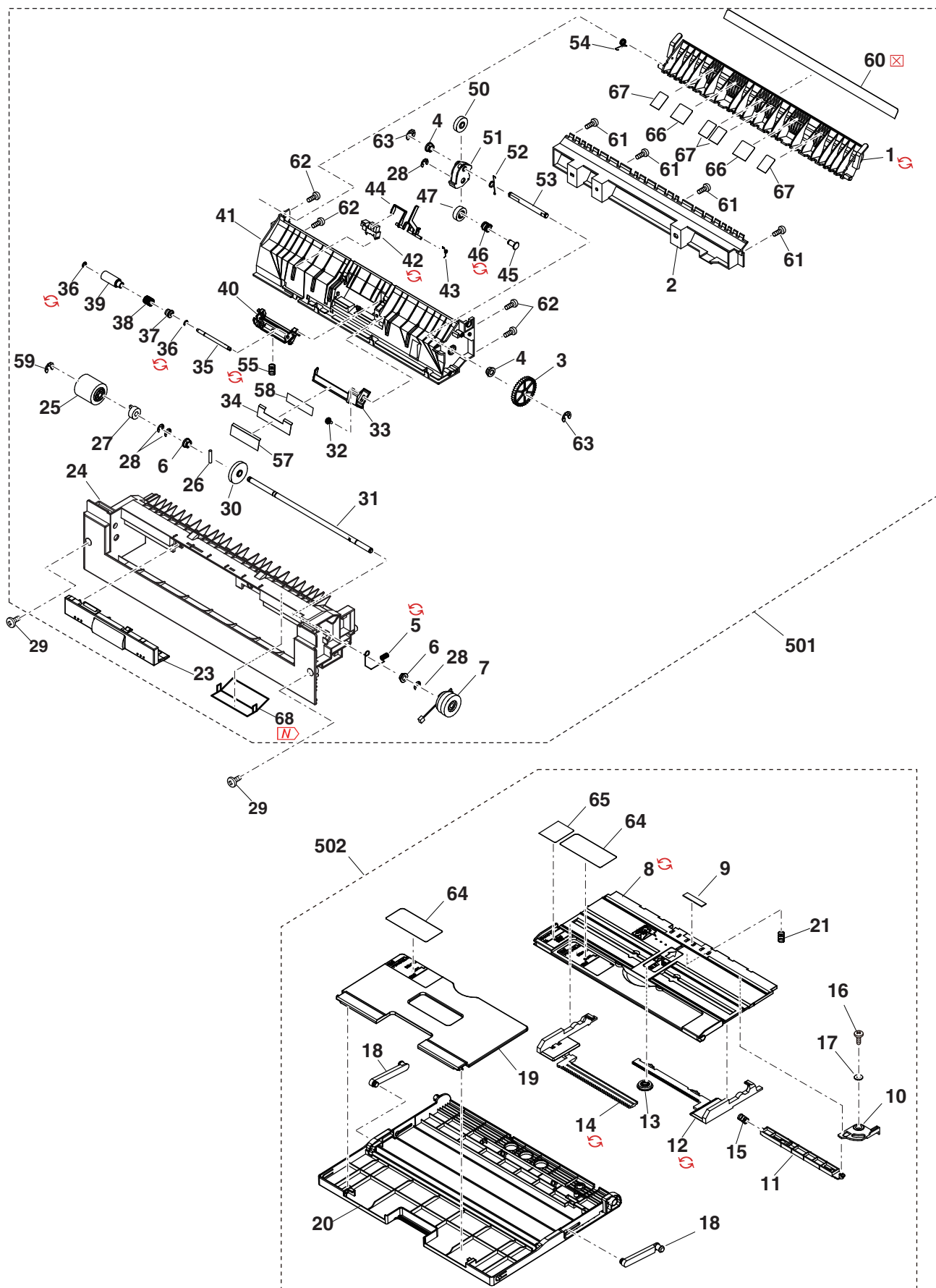



23 サイドドアユニット (side door unit)

NO.	PARTS CODE	Inter-change	PRICE Ex.	RANK Ja.	NEW MARK	PART RANK	DESCRIPTION	Reason for change	Effective time
1	PGiDM0244QSZZ		AW	FG	N	C	Inner イナ-		
2	MSPRC0612QSZZ		AD	DJ	N	C	Transfer TC high voltage spring 転写 TC 高圧スプリング		
	Ⓢ MSPRC0612QSZ1	1	AD	DJ	N	C	Transfer TC high voltage spring 転写 TC 高圧スプリング	Productivity improvement	15/Jun
3	MSPRC0611QSZZ		AD	DJ	N	C	Transfer BC high voltage spring 転写 BC 高圧スプリング		
	Ⓢ MSPRC0611QSZ1	1	AD	DJ	N	C	Transfer BC high voltage spring 転写 BC 高圧スプリング	Productivity improvement	15/Jun
4	XEBS730P08000		AC	DD		C	Screw(3×8) ビス		
5	XHBS730P16000		AA	DD		C	Screw(3×16) ビス		
6	PCLR-0485FCZZ		AD	DJ		C	U-turn collar Uターンコ		
7	MSPRC0640QSZZ		AC	DD	N	C	Right door follower spring 右ドア従動スプリング		
8	NSFTZ0198QSZZ		AF	DS	N	C	Right door follower shaft 右ドア従動シャフト		
9	NR0LP1734FCZ1		AG	DX		C	Transport follower roller(φ16) 搬送従動ローラ		
10	XRESP30-06000		AA	DD		C	E type ring(E3) Eリング		
11	MSPRC0614QSZZ		AD	DJ	N	C	TC case GND spring TCケースGNDスプリング		
12	LPLTM0832QSZZ		AC	DD	N	C	DUP roller earth plate DUPローラース板		
13	LPLTM0807QSZZ		AD	DJ	N	C	Side door reinforce plate R サイドドア補強板 R		
14	XHBS730P10000		AD	DD		C	Screw(3×10) ビス		
15	LRALP0004QSZZ		AF	DS		C	Right door rail 右ドアレール		
16	LPLTM0806QSZZ		AD	DJ	N	C	Side door reinforce plate F サイドドア補強板 F		
17	LPLTM0363QSZZ		AF	DS		C	Rail reinforce plate レール補強板		
18	XRESP40-06000		AA	DD		C	E type ring(E4) Eリング		
19	PCLR-0027QSZZ		AC	DD	N	C	DUP roller collar DUPローラーカー		
20	NGERH0420QSZZ		AD	DJ	N	C	Gear(23T) ギヤ		
21	LPI NS0327FCZZ		AC	DJ		C	Spring pin(φ2-10) スプリングピン		
22	NBRGP0897FCZ2		AC	DD		C	ADU bearing ADU軸受		
23	NR0LR0242QSZZ		AN	EG	N	A	DUP roller DUPローラ		
24	GDOR-0008QSZZ		AY	FQ	N	D	Side door サイドドア		
	Ⓢ GDOR-0008QSZ1	3	AY	FQ		D	Side door サイドドア	Improve performance	14/Dec RC
25	MSPRD0653QSZZ		AC	DD	N	C	Lock spring ロックスプリング		
26	MLEVP0183QSZZ		AF	DS	N	C	Lock lever ロックレバー		
	MLEVP0190QSZZ		AF	DS	N	C	Right door lock lever 右ドアロックレバー		
27	Ⓢ MLEVP0190QSZ1	3	AF	DS		C	Right door lock lever 右ドアロックレバー	Improve performance	14/Nov RC
28	MSPRC0643QSZZ		AD	DD	N	C	TR pressure spring R TR圧接スプリング R		
29	XRESP50-06000		AA	DD		C	E type ring(E5) Eリング		
	(Unit)								
901	CDOR-0008RS51		BG	GT	N	E	Side door unit(Refer to Matrix) [Include 24BLK] サイドドアユニット		
	CDOR-0008RS52		BH	HC	N	E	Side door unit(Refer to Matrix) [Include 24BLK] サイドドアユニット		
	CDOR-0008RS58		BM	HR	N	E	Side door unit(Refer to Matrix) [Include 24BLK] サイドドアユニット		
	Ⓢ CDOR-0008RS59	3	BM	HV	N	E	Side door unit(Refer to Matrix) [Include 24BLK] サイドドアユニット	Improve performance	14/Dec RC
	Ⓢ CDOR-0008RS60	3	BN	HZ	N	E	Side door unit(Refer to Matrix) [Include 24BLK] サイドドアユニット	Improve performance	14/Dec RC
	Ⓢ CDOR-0008RS61	-	BN	LE	N	E	Side door unit(Refer to Matrix) [Include 24BLK] サイドドアユニット	Parts code correction	1st lot

Matrix

No.901	サイドドアユニット (Side door unit)		
PARTS CODE	AR-6031N AR-6031NR AR-6131N AR-X311N AR-6026N AR-6026NR	AR-6023N AR-6023NR AR-X231N AR-6020N AR-6020NR AR-6120N AR-6020N AR-6023D AR-6020D AR-X201D	AR-6023 AR-6020 AR-X201 AR-G200
CDOR-0008RS51			1st Lot
CDOR-0008RS52		1st Lot	
CDOR-0008RS58	Correction		
Ⓢ CDOR-0008RS59			14/Dec RC
Ⓢ CDOR-0008RS60		14/Dec RC	
Ⓢ CDOR-0008RS61	1st Lot		

23 サイドドアユニット (side door unit)

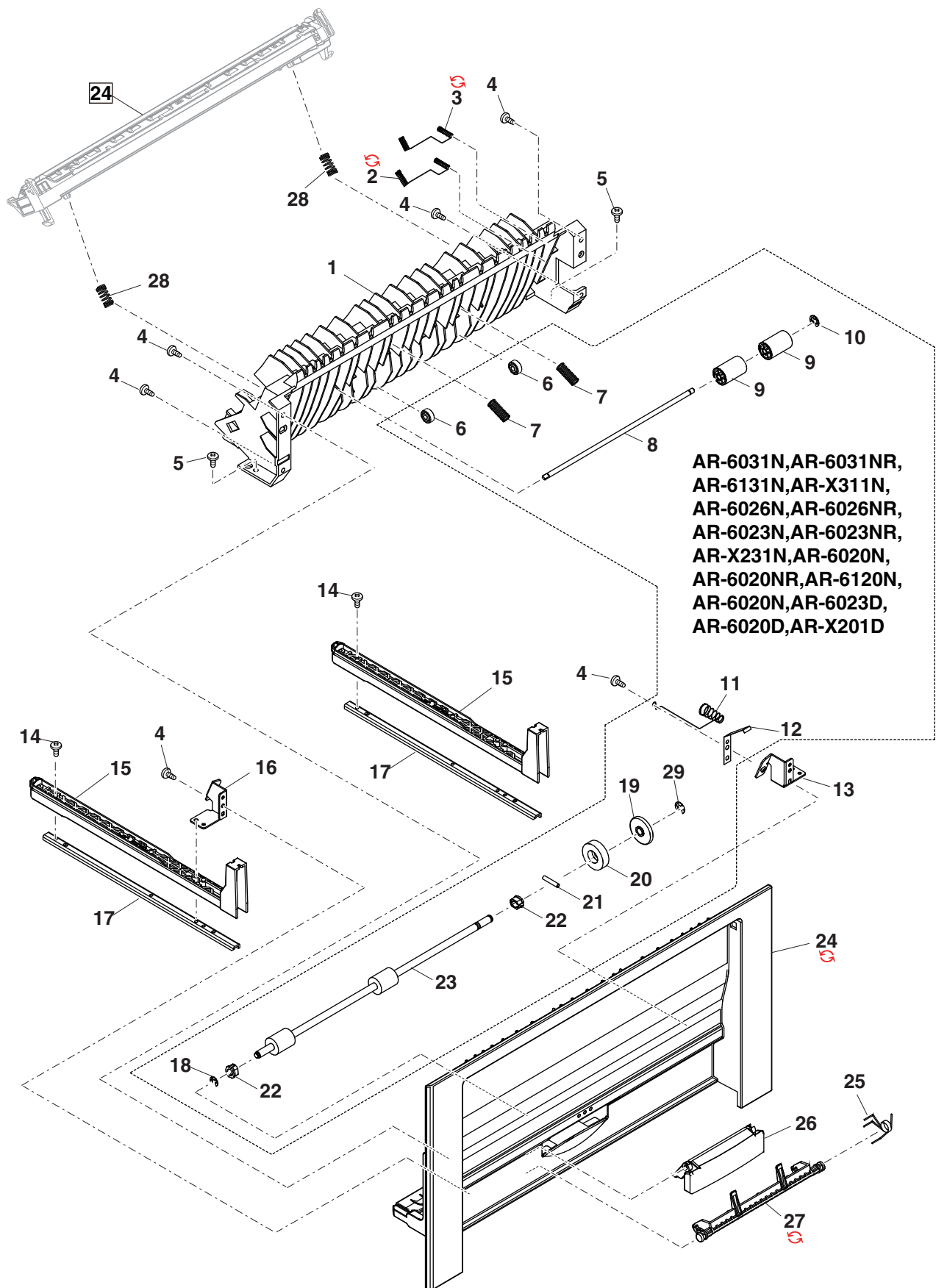

24 転写ローラーユニット (Transcer roller unit)

NO.	PARTS CODE	Inter-change	PRICE Ex.	RANK Ja.	NEW MARK	PART RANK	DESCRIPTION	Reason for change	Effective time
1	PSHEZ0865QSZZ		AE	DS	N	C	Transfer front paper guide(Refer to Matrix) 転写前ハールガイド		
	PSHEZ0903QSZZ	-	AE	DS		C	Transfer alupet(Refer to Matrix) 転写アルペット	Parts code correction	1st lot
	PSHEZ0903QSZ1	3	AK	DX	N	C	Transfer alupet(Refer to Matrix) 転写アルペット	Improve performance	14/Nov RC
	PSHEZ0903QSZ2	-	AK	DX	N	C	Transfer alupet(Refer to Matrix) 転写アルペット	Parts code correction	1st lot
2	NBRGP0086QSZZ		AC	DD	N	C	Transfer bearing F 転写軸受 F		
3	NROLR0241QSZZ		AX	FG	N	A	Transfer roller 転写ローラー		
	NROLR0241QSZ1	3	AX	FG		A	Transfer roller 転写ローラー	Improve performance	14/Dec RC
4	NBRGP0087QSZZ		AC	DD	N	C	Transfer bearing R 転写軸受 R		
5	NGERH0419QSZZ		AD	DJ	N	C	Transfer roller gear 転写ローキヤ		
	NGERH0419QSAZ	3	AD	DJ		C	Transfer roller gear 転写ローキヤ	Improve performance	14/Dec RC
6	PCLR-0026QSZZ		AC	DD	N	C	Transfer roller collar 転写ローカー		
	PCLR-0026QSZ1	-	AC	DD	N	C	Transfer roller collar 転写ローカー	Parts code correction	1st lot
7	XRESP40-06000		AA	DD		C	E type ring(E3) Eリング		
8	MSPRC0641QSZZ		AC	DD	N	C	Transfer pressure spring F(Refer to Matrix) 転写加圧スプリング F		
	MSPRC0613QSZZ		AC	DD	N	C	Transfer pressure spring(Refer to Matrix) 転写加圧スプリング		
10	QEARP0032QSZZ		AC	DD	N	C	Transfer TC spring 転写 TCバネ		
	LHLDZ0249QSZZ		AN	EG	N	C	Transfer holder 転写ホルダー		
	LHLDZ0249QSZ1	-	AN	EG		C	Transfer holder 転写ホルダー	Parts code correction	1st lot
	LHLDZ0249QSZ2	3	AN	EQ		C	Transfer holder 転写ホルダー	Improve performance	15/Mar RC
11	QEARP0033QSZZ		AC	DD	N	C	Transfer BC spring 転写 BCバネ		
12	LHLDZ0250QSZZ		AF	DS	N	C	Discharge plate holder 除電板ホルダー		
13	LPLTM0762QSZZ		AN	EG	N	C	Discharge plate 除電板		
14	MSPRC0613QSZZ		AC	DD	N	C	Transfer pressure spring 転写加圧スプリング		
	MSPRC0280QSZZ	-	AC	DJ		C	TC roller spring R 転写ロースプリング R	Parts code correction	1st lot
15	LPINS0165FCZZ		AB	DD	N	C	Spring pin スプリングピン		
	LPINS0165FCZ1	1	AB	DD		C	Spring pin スプリングピン	Productivity improvement	14/SEP RC
16	PSEL-0224QSZZ	-	AK	DX		C	Transfer cleaner pad 転写クリーナーパッド	Missing parts code	1st lot
17	LPLTM0890QSZZ	-	AH	DX	N	C	Transfer reinforce plate 転写補強板	Missing parts code	1st lot
18	XEBS730P08000	-	AC	DD		C	Screw(3x8) ビス	Missing parts code	1st lot
	(Unit)								
901	CHLDZ0249RS51		BA	FX	N	E	Transfer unit(Refer to Matrix) 転写ユニット		
	CHLDZ0249RS55		BB	GD		E	Transfer unit(Refer to Matrix) 転写ユニット		
	CHLDZ0249RS57	3	BC	GD	N	E	Transfer unit(Refer to Matrix) 転写ユニット	Improve performance	14/Dec RC
	CHLDZ0249RS58	-	BC	GD	N	E	Transfer unit(Refer to Matrix) 転写ユニット	Parts code correction	1st lot

Matrix

No.1	転写アルペット (Transfer alupet)	
PARTS CODE	AR-6031N AR-6031NR AR-6131N AR-X311N AR-6026N AR-6026NR	AR-6023N AR-6023NR AR-X231N AR-6020N AR-6020NR AR-6120N AR-6023D AR-6020D AR-X201D AR-6023 AR-6020 AR-X201 AR-G200
PSHEZ0865QSZZ		Correction
PSHEZ0903QSZZ		1st Lot
PSHEZ0903QSZ1	Correction	14/Nov RC
PSHEZ0903QSZ2	1st Lot	

No.8	転写加圧スプリング (Transfer pressure spring)	
PARTS CODE	AR-6031N AR-6031NR AR-6131N AR-X311N AR-6026N AR-6026NR	AR-6023N AR-6023NR AR-X231N AR-6020N AR-6020NR AR-6120N AR-6023D AR-6020D AR-X201D AR-6023 AR-6020 AR-X201 AR-G200
MSPRC0613QSZZ	1st Lot	
MSPRC0641QSZZ		1st Lot

## 24 転写ローラーユニット (Transcer roller unit)

No.901	転写ユニット (Transfer unit)	
PARTS CODE	AR-6031N AR-6031NR AR-6131N AR-X311N AR-6026N AR-6026NR	AR-6023N AR-6023NR AR-X231N AR-6020N AR-6020NR AR-6120N AR-6023D AR-6020D AR-X201D AR-6023 AR-6020 AR-X201 AR-G200
CHLDZ0249RS51		1st Lot
CHLDZ0249RS55	Correction	
CHLDZ0249RS57		14/Dec RC
CHLDZ0249RS58	1st Lot	

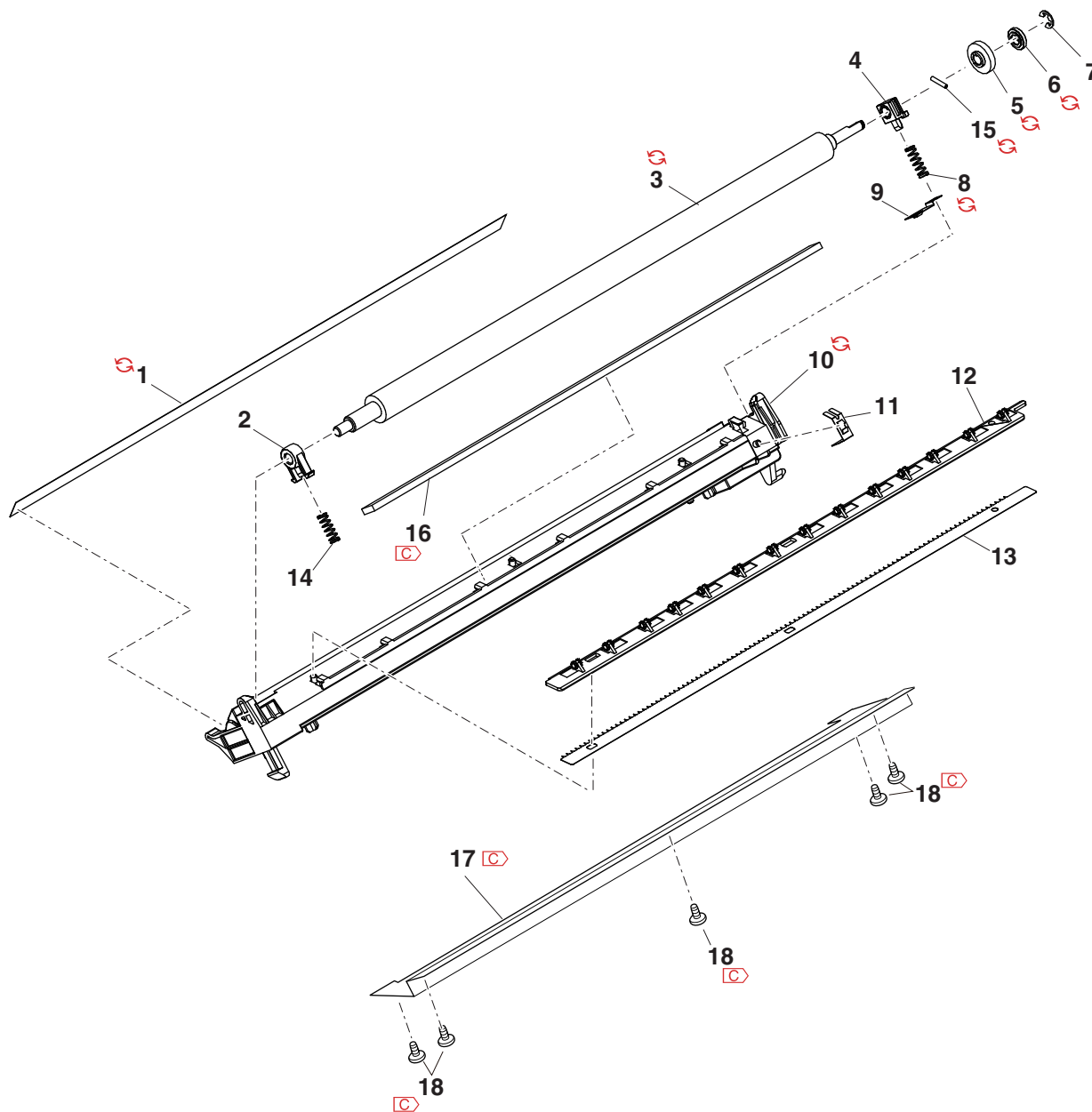

25 排紙フレーム (Delivery unit)

NO.	PARTS CODE	Inter-change	PRICE Ex.	RANK Ja.	NEW MARK	PART RANK	DESCRIPTION	Reason for change	Effective time
1	LFRM-0155QSZZ		AV	FG	N	C	Delivery upper frame 排紙上フレーム		
2	NBRGP0897FCZ1		AH	DX		C	ADU bearing ADU 軸受		
3	NRÖLR0243QSZZ		AM	EG	N	A	Delivery roller 排紙ローラー		
4	XRESP50-06000		AA	DD		C	E type ring(E5) E リング		
5	LPI NS0019QSZZ		AA	DJ		C	Spring pin(2.5×9) スプリングピン		
6	NPLYZ0060QSZZ		AD	DD	N	C	Delivery drive pulley(24T) 排紙駆動プーリー		
7	NRÖLP0240QSZZ		AP	EQ	N	A	DUP delivery roller DUP 排紙ローラー		
8	NBRGP0674FCZZ		AE	DJ		C	BLT idle bearing BLT アイドル軸受		
9	NBRGC0651FCZZ		AD	DJ		C	Bearing 軸受		
10	MSPRD0649QSZZ		AC	DD	N	C	DUP delivery roller earth spring DUP 排紙ローラーアーススプリング		
	MSPRD0649QSAZ	3			N	C	DUP delivery roller earth spring DUP 排紙ローラーアーススプリング	Improve performance	15/Jan RC
11	PBRSS0043QSZZ		AG	DS	N	A	Discharge brush 除電ブラシ		
12	LPLTM0831QSZZ		AC	DD	N	C	Delivery earth plate 排紙アース板		
	LPLTM0831QSZ1	3	AC	DD	N	C	Delivery earth plate 排紙アース板	Improve performance	15/Jan RC
13	XEBS730P08000		AC	DD		C	Screw(3×8) ビス		
14	LFRM-0163QSZZ		AP	EQ	N	C	Delivery lower frame 排紙下フレーム		
	LFRM-0163QSZ1	-	AP	EQ	N	C	Delivery lower frame 排紙下フレーム	Parts code correction	1st lot
	LFRM-0163QSZ2	3			N	C	Delivery lower frame 排紙下フレーム	Improve performance	15/Jan RC
15	MSPRD0533QSZ1		AC	DD		C	Delivery follower spring 排紙従動スプリング		
16	NRÖLP0234QSZZ		AE	DJ		C	Delivery follower roller 排紙従動ローラー		
17	PSP0-0035QSZZ		AF	DS		C	Delivery sponge 蹴り出しスポンジ		
18	NRÖLP1734FCZ1		AG	DX		C	Transport follower roller(φ16) 搬送従動ローラー		
19	NSFTZ2949FCZZ		AG	DX		C	Right door follower shaft 右ドア従動軸		
20	PGi DM0269QSZZ		AQ	EQ	N	C	Rear delivery lower paper guide 後排紙下ハールガイド		
21	MSPRC0640QSZZ		AC	DD	N	C	Right door follower spring 右ドア従動スプリング		
22	XEBS740P10000		AA	DD		C	Screw(4×10) ビス		
23	VHPSG2A141+-1		AF	DS		B	Photo sensor(SG2A141) フォトセンサー		
	VHPSG2A241+-1	1			N	B	Photo sensor(SG2A241) フォトセンサー	Productivity improvement	15/Jan
24	MLEVP0161QSAZ		AD	DJ		C	Fusing rear actuator 定着後アクチュエーター		
25	NBLTT0045QSZZ		AH	DS		B	Delivery roller drive belt 排紙ローラー駆動ベルト		
	(Unit)								
901	CFRM-0155RS51		BF	GN	N	E	Delivery unit(Refer to Matrix) 排紙ユニット		
	CFRM-0155RS52		BF	GN	N	E	Delivery unit(Refer to Matrix) 排紙ユニット		
	CFRM-0155RS53		BF	GN		E	Delivery unit(Refer to Matrix) 排紙ユニット		

Matrix

No.901	排紙ユニット (Delivery unit)		
PARTS CODE	AR-6031N AR-6031NR AR-6131N AR-X311N AR-6026N AR-6026NR	AR-6023N AR-6023NR AR-X231N AR-6020N AR-6020NR AR-6120N AR-6023D AR-6020D AR-X201D	AR-6023 AR-6020 AR-X201 AR-G200
CFRM-0155RS51			1st Lot
CFRM-0155RS52		1st Lot	
CFRM-0155RS53	1st Lot		

25 排紙フレーム (Delivery unit)

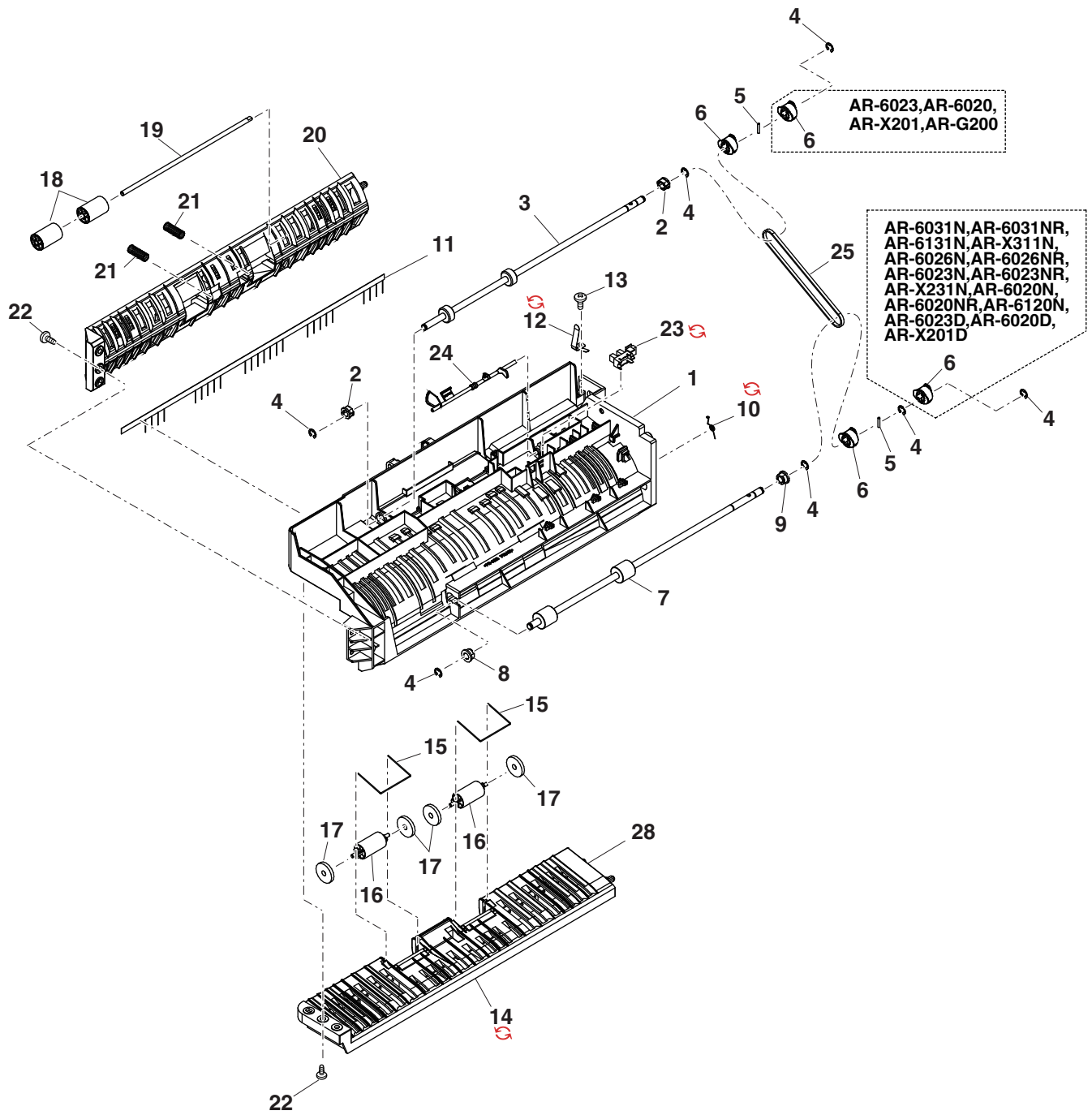

26 PS ユニット (PS unit)

NO.	PARTS CODE	Inter-change	PRICE Ex.	RANK Ja.	NEW MARK	PART RANK	DESCRIPTION	Reason for change	Effective time
1	PGiDM0240QSZZ		AT	EZ	N	C	PS left lower guide(Refer to Matrix)	PS 左下ガイド	
	PGiDM0272QSZ1		AS	EQ	N	C	PS frame(Refer to Matrix)	PS フレーム	
2	✕ PCLR-0501FCZZ	-	AB	DJ		C	Delivery guide collar	排紙ガイド	Specification change 1st lot
3	PSHEZ0876QSZZ		AC	DD	N	C	PS guide sheet	PS ガイドシート	
	NROLR0248QSZ1		AW	FG	N	A	PS roller(Refer to Matrix)	PS ローラー	
4	NROLR0248QSZ2		BT	NE	N	A	PS roller(Refer to Matrix)	PS ローラー	
	NROLR0248QSZ3		AX	FG		A	PS roller(Refer to Matrix)	PS ローラー	
5	NBRGC0018QSZZ		AD	DJ		C	Bearing	軸受	
6	NBRGC0504FCZZ		AC	DJ		C	Bearing(F8×12×5 16X)	軸受	
7	XRESP60-08000		AA	DD		C	E type ring(E6)	E リング	
8	JKNBZ0013QSZZ		AD	DJ	N	D	PS knob	PS ノブ	
9	XBPS730P10KS0		AB	DD		C	Screw(3×10KS)	ビス	
10	PGiDM0245QSZZ		AH	DX	N	C	PS right lower guide	PS 右下ガイド	
	PGiDM0245QSZ1	3	AH	DX		C	PS right lower guide	PS 右下ガイド	Improve performance 15/Dec
11	XEBS730P08000		AC	DD		C	Screw(3×8)	ビス	
12	NSFTZ0200QSZZ		AF	DS	N	C	PS follower shaft	PS 従動軸	
13	NKOM-0012QSZZ		AC	DD	N	C	PS follower collar	PS 従動コリヤ	
14	MSPRC0604QSZZ		AC	DD	N	C	PS follower spring(Refer to Matrix)	PS 従動スプリング	
	MSPRC0604QSZ1		AC	DD	N	C	PS follower spring(Refer to Matrix)	PS 従動スプリング	
15	MSPRD0637QSZZ		AE	DJ	N	C	PS follower shaft earth	PS 従動軸アース	
	MSPRD0637QSAZ	3	AE	DJ		C	PS follower shaft earth	PS 従動軸アース	Improve performance 15/Jan RC
16	PGiDM0263QSZZ		AL	EB	N	C	PS follower spring holder	PS 従動スプリングホルダー	
	PGiDM0263QSZ1	3			N	C	PS follower spring holder	PS 従動スプリングホルダー	Productivity improvement 15/Apr RC
17	MLEVP0180QSZZ		AD	DD	N	C	PIN actuator	PIN アクチュエーター	
18	MSPRD0625QSZZ		AC	DD	N	C	PIN- spring	PIN- スプリング	
19	VHPSG2A141+-1		AF	DS		B	Photo sensor(SG2A141)	フォトセンサー	
	VHPSG2A241+-1	1			N	B	Photo sensor(SG2A241)	フォトセンサー	Productivity improvement 15/Jun
20	LHLDZ0240QSZZ		AF	DS		C	Cassette paper existence holder	カセット紙有無ホルダー	
21	MLEVP0182QSZZ		AE	DJ		C	Cassette paper existence detect lever	カセット紙有無検知レバー	
23	PSHEP0871QSZZ		AD	DJ	N	C	Process front sheet(Refer to Matrix)	プロセス前シート	
	PSHEP0871QSZ1	3	AD	DJ	N	C	Process front sheet(Refer to Matrix)	プロセス前シート	Improve performance 15/Jan RC
24	PSHEZ0896QSZZ		AG	DS	N	C	Toner protect sheet	トナー飛散防止マフラー	
25	XHBS730P06000		AC	DD		C	Screw(3×6)	ビス	
26	PCLC-0373FCZ1		AP	EQ		B	Clutch N(2.5KG)	クラッチ N	
27	XRESP40-06000		AA	DD		C	E type ring(E4)	E リング	
28	MSPRC0292QSZZ		AC	DJ	N	C	PS follower pressure spring	PS 従動圧接スプリング	
	MSPRC0671QSZZ	3	AC	DD	N	C	PS follower shaft joint spring	PS 従動軸接続スプリング	Improve performance 15/Mar
31	LX-WZ0198FCZ1		AA	DD		C	Poly slider	ポリスライダ	
32	MSPRC0654QSZZ		AE	DJ	N	C	PS brake spring	PS ブレーキスプリング	
33	LX-WZ1003HCZZ		AA	DD		C	Poly slider	ポリスライダ	
34	▷ LPLTM0940QSZZ	-			N	C	PS holder reinforce plate [AR-6031N,AR-6031NR,AR-6131N, AR-X311N,AR-6026N,AR-6026NR]	PS ホルダー補強板	Improve performance 15/Apr RC
35	▷ PSHEZ0935QSZZ	-	AC	DD	N	C	TC front sheet [AR-6031N,AR-6031NR,AR-6131N, AR-X311N,AR-6026N,AR-6026NR]	TC 前マフラー	Improve performance 15/Feb RC
(Unit)									
901	DUNT-1233RS11		BF	GN	N	E	PS fixing plate unit(Refer to Matrix)	PS 固定板ユニット	
	DUNT-1233RS15		BG	GT	N	E	PS fixing plate unit(Refer to Matrix)	PS 固定板ユニット	
	DUNT-1233RS16		BE	GN	N	E	PS fixing plate unit(Refer to Matrix)	PS 固定板ユニット	

Matrix

No.1	PS 左下ガイド (PS left lower guide)	
PARTS CODE	AR-6031N AR-6031NR AR-6131N AR-X311N AR-6026N AR-6026NR	AR-6023N AR-6023NR AR-X231N AR-6020N AR-6020NR AR-6120N AR-6023D AR-6020D AR-X201D AR-6023 AR-6020 AR-X201 AR-G200
PGiDM0240QSZZ		1st Lot
PGiDM0272QSZ1	1st Lot	

26 PS ユニット (PS unit)

No.4		PS ローラー (PS roller)	
PARTS CODE	AR-6031N AR-6031NR AR-6131N AR-X311N AR-6026N AR-6026NR	AR-6023N AR-6023NR AR-X231N AR-6020N AR-6020NR AR-6120N AR-6023D AR-6020D AR-X201D AR-6023 AR-6020 AR-X201	AR-G200
NROLR0248QSZ1		1st Lot	
NROLR0248QSZ2			1st Lot
NROLR0248QSZ3	1st Lot		

No.14		PS 従動スプリング (PS follower spring)	
PARTS CODE	AR-6031N AR-6031NR AR-6131N AR-X311N AR-6026N AR-6026NR AR-G200	AR-6023N AR-6023NR AR-X231N AR-6020N AR-6020NR AR-6120N AR-6023D AR-6020D AR-X201D AR-6023 AR-6020 AR-X201	
MSPRC0604QSZ1	1st Lot		
MSPRC0604QSZZ		1st Lot	

No.23		プロセス前シート (Process front sheet)	
PARTS CODE	Americas1 Europe Australia Asia Class B	Japan(日本)	
PSHEP0871QSZ1	1st Lot	1st Lot	
PSHEP0871QSZZ	15/Jan RC		

No.901		PS 固定板ユニット (PS fixing plate unit)	
PARTS CODE	AR-6031N AR-6031NR AR-6131N AR-X311N AR-6026N AR-6026NR	AR-6023N AR-6023NR AR-X231N AR-6020N AR-6020NR AR-6120N AR-6023D AR-6020D AR-X201D AR-6023 AR-6020 AR-X201	AR-G200
DUNT-1233RS11		1st Lot	
DUNT-1233RS15			1st Lot
DUNT-1233RS16	1st Lot		



26 PSユニット (PS unit)

AR-6023N,AR-6023NR,  
AR-X231N,AR-6020N,  
AR-6020NR,AR-6120N,  
AR-6023D,AR-6020D,  
AR-X201D,AR-6023,  
AR-6020,AR-X201,  
AR-G200

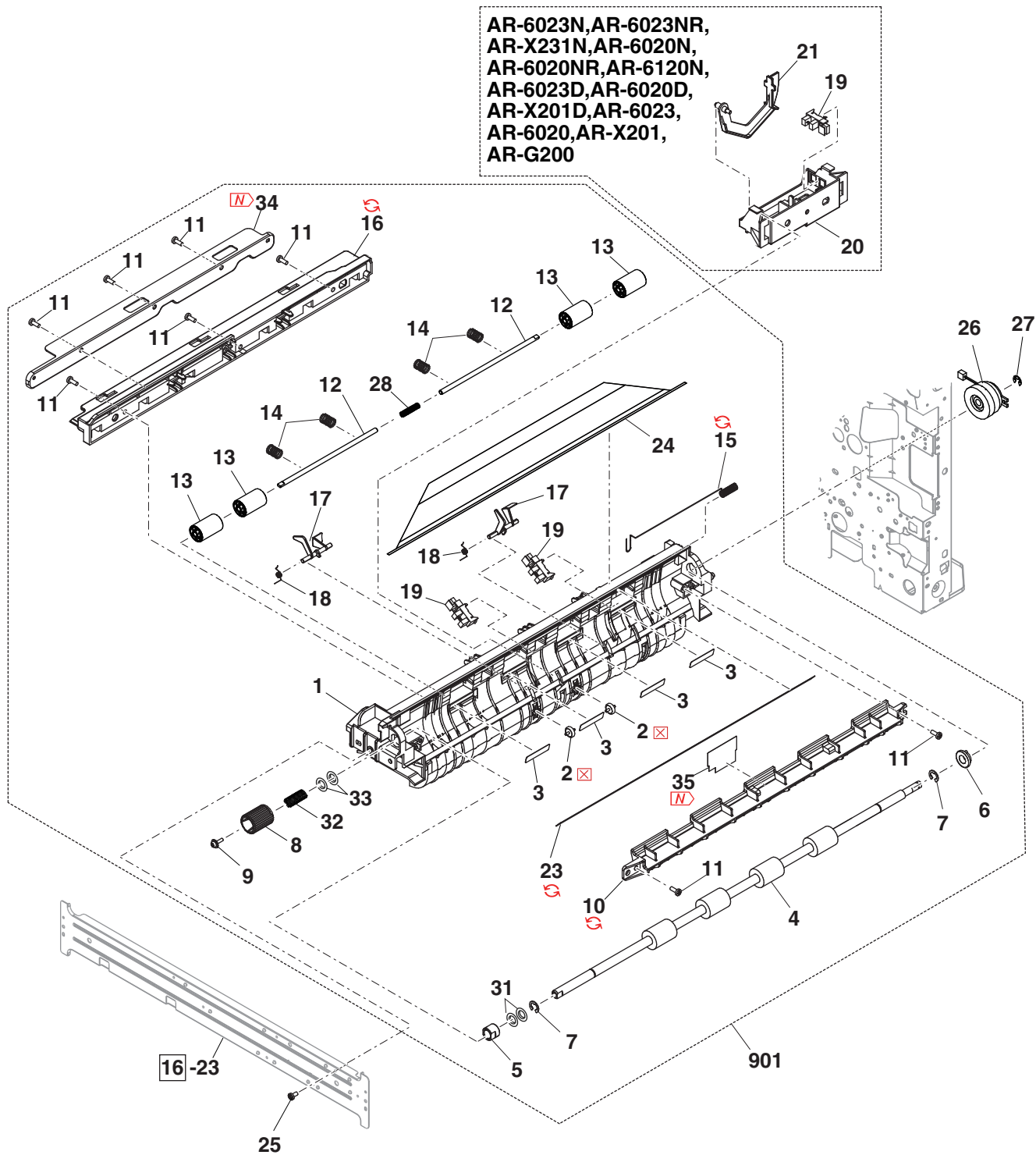

27 フレームセクション 1(Frame section 1)

NO.	PARTS CODE	Inter-change	PRICE Ex.	RANK Ja.	NEW MARK	PART RANK	DESCRIPTION	Reason for change	Effective time
1	DUNTK1274QS11		BW	RB	N	E	LSU(Refer to Matrix)	LSU	
	DUNTK8747QSZZ		BV	RB	N	E	LSU(Refer to Matrix)	LSU	
	XBPS730P10KS0		AB	DD			Screw(3×10KS)	ビス	
3	GCAB-0237QSZZ	-	AD	DD	N	D	LSU harness cover	LSU ハーネスカバー	Specification change
4	XHBS730P06000	-	AC	DD		C	Screw(3×6)	ビス	Specification change
5	LPLTM0748QSZZ		AN	EG	N	C	Corner frame front upper	コーナーフレーム前上	
	LPLTM0748QSZ1	3	AN	EG		C	Corner frame front upper	コーナーフレーム前上	Specification change
	LPLTM0748QSZ2	3	AN	EG	N	C	Corner frame front upper	コーナーフレーム前上	Improve performance
6	CPLTM0751QS01		AY	FQ	N	C	LSU fixing plate assy	LSU 固定板アッセンブリ	
	CPLTM0751QS02	3	AY	FQ		C	LSU fixing plate assy	LSU 固定板アッセンブリ	Productivity improvement
7	CPLTM0741QS03		AX	FQ	N	C	Left joint plate(Refer to Matrix)	左連接板	
	CPLTM0741QS04	3	AX	FQ	N	C	Left joint plate(Refer to Matrix)	左連接板	Improve performance
	LPLTM0741QSZZ		AV	FG	N	C	Left joint plate(Refer to Matrix)	左連結板	
8	PGiDM0260QSZZ		AE	DJ	N	C	Cassette guide plate upper(Refer to Matrix)	カセットガイド板上	
	PGiDM0260QSZ1	-	AE	DJ	N	C	Cassette guide plate upper(Refer to Matrix)	カセットガイド板上	Parts code correction
	LHLDZ0289QSZ1		AF	DS	N	C	Cassette guide plate upper(Refer to Matrix)	カセットガイド板上	
9	XEBS740P08000		AA	DD		C	Screw(4×8)	ビス	
	LHLDZ0263QSZZ		AD	DD	N	C	Front corner foot(Refer to Matrix)	前角足	
10	LHLDZ0263QSZ1	3	AD	DD	N	C	Front corner foot(Refer to Matrix)	前角足	Improve performance
	LHLDZ0273QSZ1		AD	DJ	N	C	Front corner foot(Refer to Matrix)	前角足	
11	LPLTM0747QSZZ		AN	EG	N	C	Corner frame right upper	コーナーフレーム右上	
	LPLTM0747QSZ1	-	AN	EG		C	Corner frame right upper	コーナーフレーム右上	Specification change
12	LPLTM0754QSZZ		AD	DJ	N	C	Corner reinforce plate	コーナー補強板	
	LPLTM0754QSZ1	-	AD	DJ		C	Corner reinforce plate	コーナー補強板	Specification change
13	GCAB-0235QSZZ		AF	DS	N	C	Side door rail F	サイドドアレールF	
14	LHLDZ0270QSZZ		AD	DJ	N	C	Side door switch holder	サイドドアスイッチホルダー	
15	CSW-M0521RS58		AT	EZ	N	B	Interlock switch(Refer to Matrix)	インターロックスイッチ	
	CSW-M0521RS60		AU	EZ		B	Interlock switch(Refer to Matrix)	インターロックスイッチ	
16	XEPS723P12000		AA	DD		C	Screw(2.3×12)	ビス	
17	MLEVP0071QSZZ		AD	DJ		C	ILSW lever	ILSW レバー	
18	MSPRT0221QSZZ		AB	DJ		C	ILSW spring	ILSW スプリング	
19	GCAB-0236QSZZ		AE	DJ	N	C	Side door rail R	サイドドアレールR	
20	PGiDM0243QSZZ		AM	EG	N	C	DV guide	DV ガイド	
21	LPLTM6022FCZZ		AC	DJ		C	M4 plate N	M4 プレートN	
22	LPLTM0753QSZZ		AT	EZ	N	C	Support plate(Refer to Matrix)	補助板	
	LPLTM0753QSZ1	3	AT	EZ	N	C	Support plate(Refer to Matrix)	補助板	Specification change
	LPLTM0753QSZ2		AT	EZ		C	Support plate(Refer to Matrix)	補助板	
23	LPLTM0739QSZZ		AP	EQ	N	C	Corner frame front	コーナーフレーム前	
	LPLTM0739QSZ1	-	AR	EQ	N	C	Corner frame front	コーナーフレーム前	Parts code correction
24	LHLDZ0263QSZ1		AD	DD	N	C	Front corner foot	前角足	
25	PMLT-0135QSZZ		AC	DJ		C	PG cushion	PG マット	
26	PSHEZ0691QSZZ		AB	DD	N	C	LSU sheet 1	LSU シート 1	
27	PSHEZ0692QSZZ		AB	DD	N	C	LSU sheet 2	LSU シート 2	
28	CPWBF1674FCE1		AL	EB	N	B	LSU thermistor unit [AR-6023N,AR-6023NR,AR-X231N, AR-6020N,AR-6020NR,AR-6120N, AR-6023D,AR-6020D,AR-X201D,AR-6023, AR-6020,AR-X201,AR-G200]	LSU サーマスタリユニット	
29	LHLDZ0280QSZZ		AD	DD		C	Thermal sensor holder [AR-6023N,AR-6023NR,AR-X231N, AR-6020N,AR-6020NR,AR-6120N, AR-6023D,AR-6020D,AR-X201D,AR-6023, AR-6020,AR-X201,AR-G200]	温度センサーホルダー	
30	LPLTM0822QSZ2		AH	DX	N	C	Cassette guide plate left [AR-6031N,AR-6031NR,AR-6131N, AR-X311N,AR-6026N,AR-6026NR]	カセットガイド板上左	
31	PCLR-0519FCZZ		AE	DS		C	Cassette rail collar [AR-6031N,AR-6031NR,AR-6131N, AR-X311N,AR-6026N,AR-6026NR]	カセットレールコリ	
32	NSFTZ0212QSZ1		AG	DS	N	C	Left collar shaft [AR-6031N,AR-6031NR,AR-6131N, AR-X311N,AR-6026N,AR-6026NR]	左コリ軸	
33	LPLTM0857QSZZ		AC	DD		C	Left front reinforce plate	左前補強板	
34	LPLTM0858QSZZ		AL	EB		C	Right joint plate	右連結板	
35	RHET-0011QSPZ		AQ	EQ		B	Dehumidification heater [Japan(日本)]	除湿ヒーター	
36	LPLTM0821QSZZ		AN	EQ	N	C	Dehumidify heater fixing plate [Japan(日本)]	除湿ヒーター固定板	
37	LPLTP0192QSZ2		AH	DX		C	Dry heater fixing plate [Japan(日本)]	カセット除湿ヒーター取付板	
38	PMLT-0264QSZZ	-	AE	DJ		C	Dew condensation cushion A	結露マット A	Missing parts code
39	PMLT-0265QSZZ	-	AD	DJ		C	Dew condensation cushion B	結露マット B	Missing parts code
40	XBPS730P06KS0		AB	DD		C	Screw(3×6K)	ビス	

27 フレームセクション 1(Frame section 1)

NO.	PARTS CODE	Inter-change	PRICE RANK		NEW MARK	PART RANK	DESCRIPTION	Reason for change	Effective time
			Ex.	Ja.					
41	LX-BZ0111QSZZ		AB	DJ	N	C	ScrewM3x6		
42	NFANP0127FCPZ		AW	FG		B	Power supply fan [AR-6031N,AR-6031NR,AR-6131N,AR-X311N,AR-6026N,AR-6026NR]		
43	PDUC-0031QSZ1		AR	EQ	N	C	DV cooling duct upper [AR-6031N,AR-6031NR,AR-6131N,AR-X311N,AR-6026N,AR-6026NR]		
44	PDUC-0032QSZ2		AQ	EQ	N	C	DV cooling duct lower [AR-6031N,AR-6031NR,AR-6131N,AR-X311N,AR-6026N,AR-6026NR]		
45	XEBS740P35000		AC	DD		C	Screw(4x35) [AR-6031N,AR-6031NR,AR-6131N,AR-X311N,AR-6026N,AR-6026NR]		
46	PSHEZ0929QSZZ	-	AL	EB	N	C	Dehumidify heater protect sheet [Japan(日本)]	除湿ヒーター保護マター	Missing parts code 1st lot

Matrix

No.1	LSU(LSU)
PARTS CODE	AR-6031N AR-6031NR AR-6131N AR-X311N AR-6026N AR-6026NR
DUNTK1274QS11	1st Lot
DUNTK8747QSZZ	1st Lot

No.7	左連接板 (Left joint plate)
PARTS CODE	AR-6031N AR-6031NR AR-6131N AR-X311N AR-6026N AR-6026NR
CPLTM0741QS03	1st Lot
CPLTM0741QS04	15/May RC
LPLTM0741QSZZ	1st Lot

No.8	カセットガイド板上 (Cassette guide plate upper)
PARTS CODE	AR-6031N AR-6031NR AR-6131N AR-X311N AR-6026N AR-6026NR
PGiDM0260QSZZ	Correction
LHLDZ0289QSZ1	1st Lot
PGiDM0260QSZ1	1st Lot

No.10	前角足 (Front corner foot)
PARTS CODE	AR-6031N AR-6031NR AR-6131N AR-X311N AR-6026N AR-6026NR
LHLDZ0263QSZZ	1st Lot
LHLDZ0273QSZ1	1st Lot
LHLDZ0263QSZ1	14/Nov

No.15	インターロックスイッチ (Interlock switch)
PARTS CODE	AR-6031N AR-6031NR AR-6131N AR-X311N AR-6026N AR-6026NR
CSW-M0521RS58	1st Lot
CSW-M0521RS60	1st Lot

27 フレームセクション 1(Frame section 1)

No.22	補助板 (Support plate)	
PARTS CODE	AR-6031N AR-6031NR AR-6131N AR-X311N AR-6026N AR-6026NR	AR-6023N AR-6023NR AR-X231N AR-6020N AR-6020NR AR-6120N AR-6023D AR-6020D AR-X201D AR-6023 AR-6020 AR-X201 AR-G200
LPLTM0753QSZZ		1st Lot
 LPLTM0753QSZ1		15/Jan RC
LPLTM0753QSZ2	1st Lot	

27 フレームセクション 1(Frame section 1)

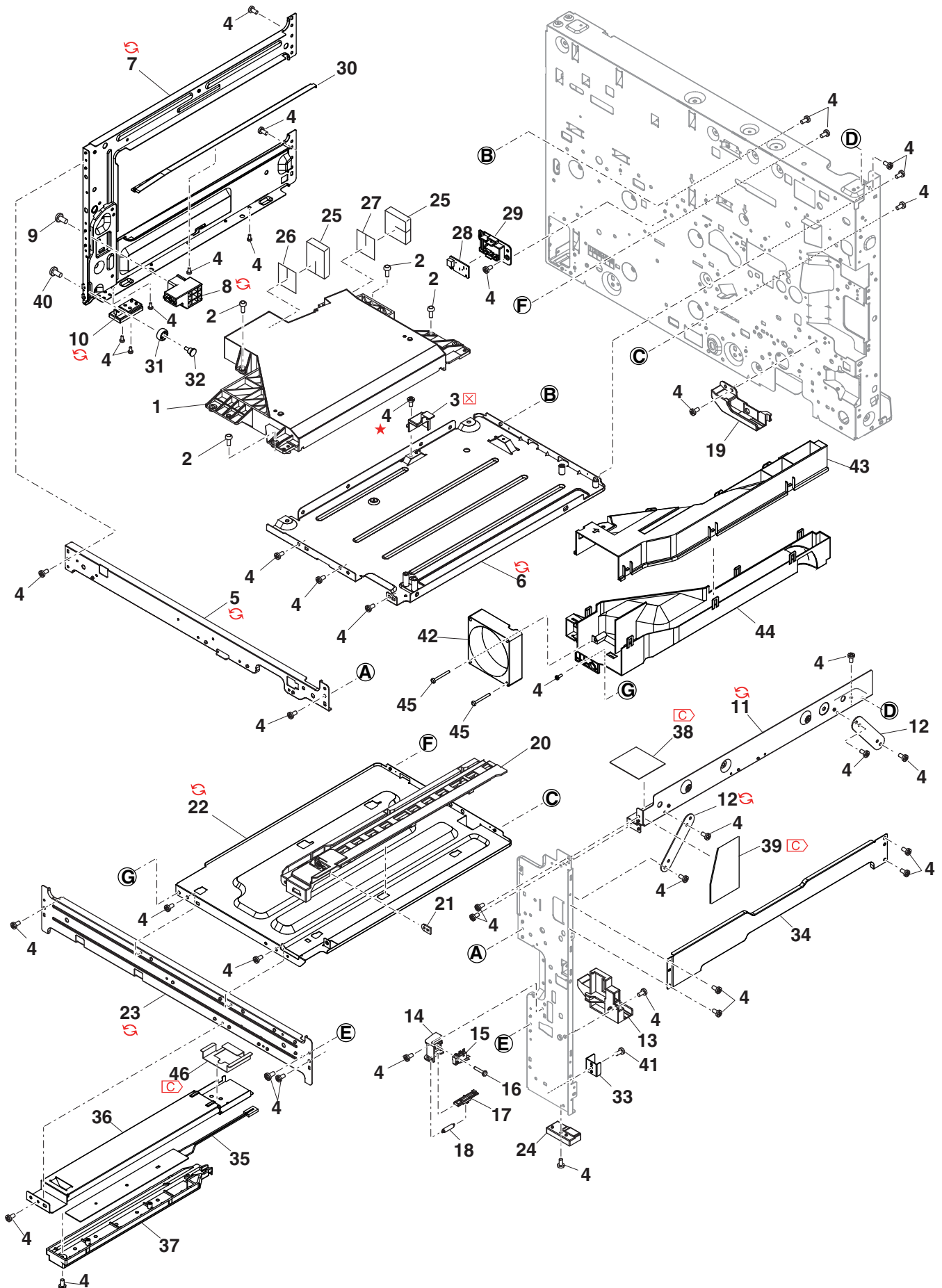

28 フレームセクション 2(Frame section 2)

NO.	PARTS CODE	Inter-change	PRICE Ex.	RANK Ja.	NEW MARK	PART RANK	DESCRIPTION	Reason for change	Effective time
1	LX-BZ0335FCPZ		AB	DD		C	Red screw(4×6S/SW)		
2	LPLTM6542FCZZ		AD	DJ		C	Scanner adjustment plate		
	CPLTM0745QS01		AU	EZ	N	C	Corner frame left upper assy		
3	CPLTM0745QS02	3	AU	EZ		C	Corner frame left upper assy	Specification change	14/Nov
4	XHBS730P06000		AC	DD		C	Screw(3×6)		
5	XHBS740P08000		AA	DD		C	Screw(4×8)		
6	XEBS740P08000		AA	DD		C	Screw(4×8)		
7	GLEGG0008QSZZ		AC	DD		C	Rubber foot		
8	LPLTM0800QSZZ		AD	DD	N	C	DUP gear reinforce plate [AR-6031N,AR-6031NR,AR-6131N, AR-X311N,AR-6026N,AR-6026NR, AR-6023N,AR-6023NR,AR-X231N, AR-6020N,AR-6020NR,AR-6120N, AR-6020N,AR-6023D,AR-6020D,AR-X201D]	DUPギア補強板	
9	ML0KZ0011FCZ1		AC	DJ		C	Cassette lock		
10	LPLTM0750QSZZ		AD	DJ	N	C	Fusing rear fixing plate		
	LHLDZ0245QSZ1		AG	DS	N	C	CRUM connector holder(Refer to Matrix)		
	LHLDZ0245QSZZ		AG	DS	N	C	CRUM connector holder(Refer to Matrix)		
11	LHLDZ0245QSZ2	3	AG	DS		C	CRUM connector holder(Refer to Matrix)	Productivity improvement	15/Jan
	LHLDZ0245QSZ3	3	AG	DS		C	CRUM connector holder(Refer to Matrix)	Productivity improvement	15/Jan
	LFRM-0161QSZZ		AP	EQ	N	C	DR rail		
12	LFRM-0161QSZ1	3	AP	EQ		C	DR rail	Improve performance	15/Jan
13	LX-BZ1189FCZZ		AB	DD		C	Step screw		
14	LPLTM0738QSZZ		AP	EQ	N	C	Corner frame right lower		
	LRALP0025QSZZ		AR	EQ	N	C	Cassette guide plate right		
15	LRALP0025QSZ1	-	AR	EQ	N	C	Cassette guide plate right	Parts code correction	1st lot
	LRALP0027QSZ1		AR	EQ	N	C	Cassette guide plate right [AR-6031N,AR-6031NR,AR-6131N, AR-X311N,AR-6026N,AR-6026NR]		
16	LPLTM0752QSZZ		AR	EQ	N	C	Fusing guide plate		
17	LPLTM0884QSZZ		AD	DJ		C	protect plate [AR-6023,AR-6020,AR-X201,AR-G200]		
	LPLTM0886QSZZ		AE	DJ	N	C	Fusing gear fixing plate(Refer to Matrix)		
18	LPLTM0886QSZ1	3	AE	DJ	N	C	Fusing gear fixing plate(Refer to Matrix)	Improve performance	14/Dec RC
	LPLTM0892QSZ1		AD	DJ	N	C	Fusing gear fixing plate(Refer to Matrix)		
19	MARMP0091QSZ1		AD	DJ	N	C	Separation pawl arm		
20	NKOM-0005QSZZ		AC	DJ		C	Cassette guide collar		
21	NSFTZ0137QSZ1		AF	DS		C	Cassette collar shaft		
22	XBPS730P08KS0		AB	DD		C	Screw(3×8KS)		
23	RPLU-0024QSP1		AM	EG		B	Pawl solenoid		
24	XBBS730P05000		AA	DD		C	Screw(3×5)		
25	PSHEZ0918QSZ1		AG	DX	N	C	Solenoid harness sheet		
26	PMLT-0274QSZZ		AC	DD	N	C	Solenoid damper cushion		
27	PMLT-0273QSZZ		AB	DD	N	C	Separation pawl arm damper cushion		
28	MSPRC1318FCZ1		AA	DJ		C	Manual paper feed spring B		

Matrix

No.11	クラムコネクタホルダ - (CRUM connector holder)	
PARTS CODE	Europe Australia Asia10 Japan(日本)	Americas Asia1 Asia2 Asia3 Asia4 Asia6 ClassB
LHLDZ0245QSZZ	1st Lot	
LHLDZ0245QSZ1		1st Lot
LHLDZ0245QSZ2	1st Lot	
LHLDZ0245QSZ3		1st Lot

No.18	定着ギア補強板金 (Fusing gear fixing plate)	
PARTS CODE	AR-6031N AR-6031NR AR-6131N AR-X311N AR-6026N AR-6026NR	AR-6023N AR-6023NR AR-X231N AR-6020N AR-6020NR AR-6120N AR-6023D AR-6020D AR-X201D AR-6023 AR-6020 AR-X201 AR-G200
LPLTM0886QSZZ		1st Lot
LPLTM0886QSZ1		14/Dec RC
LPLTM0892QSZ1	1st Lot	

28 フレームセクション 2(Frame section 2)

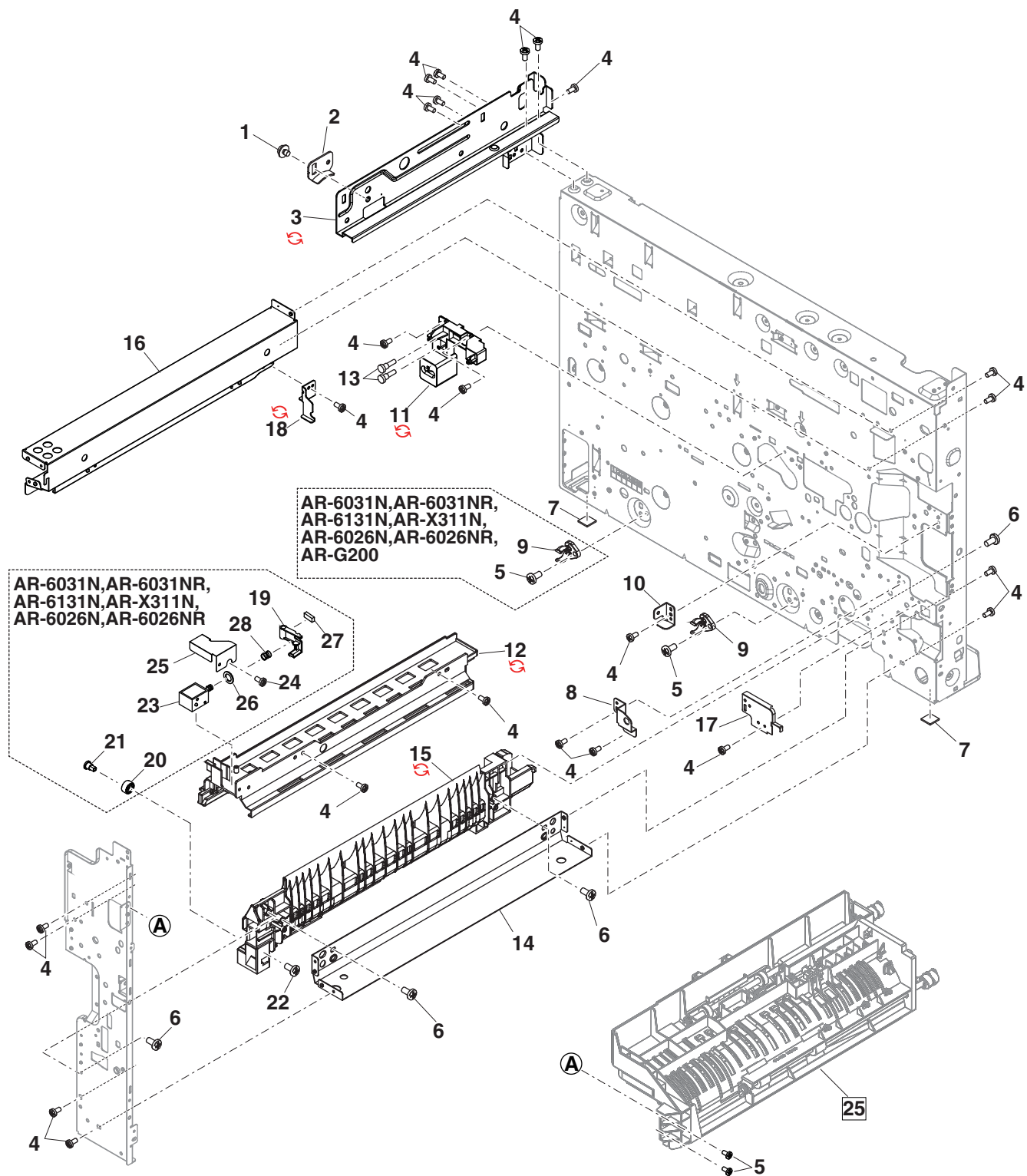



29 フレームセクション 3(Frame section 3)

[AR-6031N,AR-6031NR,AR-6131N,AR-X311N,AR-6026N,AR-6026NR]

NO.	PARTS CODE	Inter-change	PRICE Ex.	RANK Ja.	NEW MARK	PART RANK	DESCRIPTION	Reason for change	Effective time	
1	LX-BZ0030QSPZ		AC	DD		C	Fan fixing Screw	ファン固定ビス		
2	NFANP0127FCPZ		AW	FG		B	Power supply fan	電源ファン		
3	PDUC-0029QSZZ		AP	EQ	N	C	Fan duct outside	ファンダクト外		
4	XHBS730P06000		AC	DD		C	Screw(3x6)	ビス		
4	XHBS730P08000		AB	DD		C	Screw(3x8)	ビス		
5	QSW-C9295QCPZ		AL	EB		B	Main power switch	メイン電源スイッチ		
6	LFI X-0016FCZZ		AD	DJ		C	AC cord fixture [120V]	ACコード押え		
7	XBPS740P20XS0		AC	DD		C	Screw(4x20) [120V]	ビス		
8	XHBS740P08000		AA	DD		C	Screw(4x8)	ビス		
9	PFI LZ0041QSZZ		AU	FG	N	A	Ozone filter	オゾンフィルター		
10	LPLTM0757QSZZ		AF	DS	N	C	Power supply inlet plate [200V Series]	電源インレット板		
11	XBBS740P08000		AA	DD		C	Screw(3x8) [200V Series]	ビス		
12	XBPSN40P06K00		AA	DD		C	Screw(4x6)	ビス		
13	T LABZ4868FCZ1		AB	DJ		D	Earth label [200V Series]	アースラベル		
14	NFANP0027QSPZ		AP	EQ		B	PS fan	PSファン		
15	XBPS730P32KS0		AC	DD		C	Screw(3x32)	ビス		
16	LPLTM0756QSZZ		AF	DS	N	C	Power supply fan fixing plate	電源ファン固定板		
17	PCOVP0218QSZZ		AE	DS	N	C	TN drive cover	TN 駆動カバー		
18	VHPSG2A141+-1	1	AF	DS		B	Photo sensor(SG2A141)	フォトセンサー	Productivity improvement	15/Jun
19	NCPL-0032QSZZ		AD	DD	N	C	TN drive coupling	TN 駆動カップリング		
20	MSPRC0605QSZZ		AC	DD	N	C	Drive spring	駆動スプリング		
21	NGERH0404QSZZ		AE	DJ	N	C	Gear(77T)	ギヤ		
22	NGERH0403QSZZ		AD	DJ	N	C	Gear(79/20T)	ギヤ		
23	NGERH0402QSZZ		AD	DJ	N	C	Gear(29/11T)	ギヤ		
24	PBOX-0032QSZZ		AF	DS	N	C	TN drive box	TN 駆動ボックス		
25	DUNT-1220RS51		AV	FG	N	E	TN motor unit	TN モーターユニット		
26	XEBS730P08000		AC	DD		C	Screw(3x8)	ビス		
27	XHBS730P35000		AK	DX		C	Screw(3x35)	ビス		
28	CCOVP1607FC458		AX	FG		E	Lift up unit	リフトアップユニット		
29	MSPRC2907FCZ1		AC	DJ		C	Lift up spring	リフトアップスプリング		
30	NCPL-0052FCZ1		AH	DX		B	Lift coupling	リフトカップリング		
31	CPLTM0923QS02		AN	EQ	N	C	Lift fixing plate	リフト取付板		
32	LPLTM0926QSZZ		AD	DJ	N	C	Paper feed roller shaft fixing plate	給紙ローラー軸固定板		
33	NBRGM0968FCZZ		AC	DD		C	Mirror bearing N	ミラー軸受 N		
34	PCLC-0024QSZZ		AX	FG		B	Paper feed clutch(42T)	給紙クラッチ		
35	NGERH0438QSZ1		AD	DD	N	C	Paper feed clutch joint gear	給紙クラッチ連結ギヤ		
36	CPLTM0789QS02		AP	EQ		C	2nd joint drive plate assy	2nd 連結駆動板アッセン		
37	NGERH1169FCZZ		AF	DS		C	2nd Joint gear	2nd 連結ギヤ		
38	NGERH0430QSZZ		AD	DJ		C	Joint front drive gear	連結前駆動ギヤ		
39	NGERH2304FCZZ		AE	DJ		C	Gear(40T)	ギヤ		
40	LPLTM0887QSZZ		AD	DD		C	Fusing support plate	定着支持板		
41	LPLTM0840QSZZ		AE	DJ	N	C	Fusing connector fixing plate	定着コネクタ取付板		
42	XRESP50-06000		AA	DD		C	E type ring(E5)	E リング		
43	XRESP70-08000		AA	DD		C	E type ring(E7)	E リング		
44	RMOTS0093QSPZ		AY	FQ	N	B	DUP motor	DUP モーター		
45	PSHEZ0919QSZZ		AH	DX	N	C	HT harness protect sheet	HT ハーネス保護シート		
46	CPLTM0761QS01		AM	EG	N	C	DUP drive plate assy	DUP 駆動板アッセン		
47	NPLYZ0057QSZZ		AD	DJ	N	C	Gear(35-22T)	ギヤ		
48	LX-WZ0002QSZ1		AB	DD		C	PO belt washer	PO ヘルムワッシャー		
49	NGERH0439QSZZ		AD	DJ	N	C	DUP reduction gear(31T)	DUP 減速ギヤ		
50	MSPRC1315FCZ1		AD	DJ		C	Manual paper feed clutch spring A	手差しクラッチスプリング A		
51	NGERH0418QSZZ		AE	DJ	N	C	DUP reduction gear(22T)	DUP 減速ギヤ		
52	NBLTH0551FCZZ		AR	EQ		B	DV transmission belt CL	DV 伝達ベルト CL		
53	LX-WZ0460FCZZ		AC	DD		C	Flange sheet(φ6-20)	フランジマイラー		
54	NPLYZ0058QSZZ		AD	DJ	N	C	Delivery drive gear(26-22T)	排紙駆動ギヤ		
55	NSFTZ0197QSZZ		AF	DS	N	C	DUP drive shaft	DUP 駆動シャフト		
56	RDTCH0228FCPZ		AX	FG		B	Temperature and humidity sensor	温湿度センサー		
57	NBLTT0026QSZZ		AF	DS		B	DUP drive belt	DUP 駆動ベルト		
58	XBPS740P08KS0		AB	DD		C	Screw(4x8K)	ビス		
59	DHAi-3332DS11		BB	GD		B	AC cord(Refer to Matrix)	ACコード		
	QACCBR628QCPZ		AX	FX		B	AC cord(Refer to Matrix)	ACコード		
	QACCDR412QCPZ		BL	HG		B	AC cord(Refer to Matrix)	ACコード		
	QACCER625QCPZ		AQ	EQ		B	AC cord(Refer to Matrix)	ACコード		
	QACCZR412QCPZ		BL	HL	N	B	AC cord(Refer to Matrix)	ACコード		
	QACCZR628QCPZ		AU	EZ	N	B	AC cord(Refer to Matrix)	ACコード		
	QACCZR674QCPZ		BH	HC	N	B	AC cord(Refer to Matrix)	ACコード		
	QACCZR72GQCPZ		BK	HC	N	B	AC cord(Refer to Matrix)	ACコード		
	QACCZR922QCPZ		BK	HG	N	B	AC cord(Refer to Matrix)	ACコード		
	QACCBR628QCP1	3	BA	FX	N	B	AC cord(Refer to Matrix)	ACコード	Specification change	15/Mar
QACCER625QCP1	3	AQ	EQ	N	B	AC cord(Refer to Matrix)	ACコード	Specification change	15/Mar	
60	VHPSG2A241+-1	1			N	B	Photo sensor(SG2A241)	フォトセンサー	Productivity improvement	15/Jun



29 フレームセクション 3(Frame section 3)

[AR-6031N,AR-6031NR,AR-6131N,AR-X311N,AR-6026N,AR-6026NR]

NO.	PARTS CODE	Inter-change	PRICE RANK		NEW MARK	PART RANK	DESCRIPTION	Reason for change	Effective time
			Ex.	Ja.					
501	CPLTM0761RS52		BA	FX		E	DUP drive unit DUP 駆動ユニット		

Matrix

No.59		ACコード (AC cord)									
PARTS CODE	Americas1	Europe2 Europe3 Asia 6 Asia10	Thailand	India	Asia2	Asia3	Asia4	SouthAfrica Namibia	Taiwan	Brazil	
DHA i - 3332DS11								1st Lot			
QACCBR628QCPZ					1st Lot		1st Lot				
QACCDR412QCPZ	1st Lot										
QACCER625QCPZ		1st Lot									
QACCZR412QCPZ									1st Lot		
QACCZR628QCPZ						1st Lot					
QACCZR674QCPZ				1st Lot							
QACCZR72GQCPZ										1st Lot	
QACCZR922QCPZ			1st Lot								
QACCBR628QCP1					15/Mar						
QACCER625QCP1		15/Mar									

29 フレームセクション 3(Frame section 3)  
 [AR-6031N,AR-6031NR,AR-6131N,AR-X311N,AR-6026N,AR-6026NR]

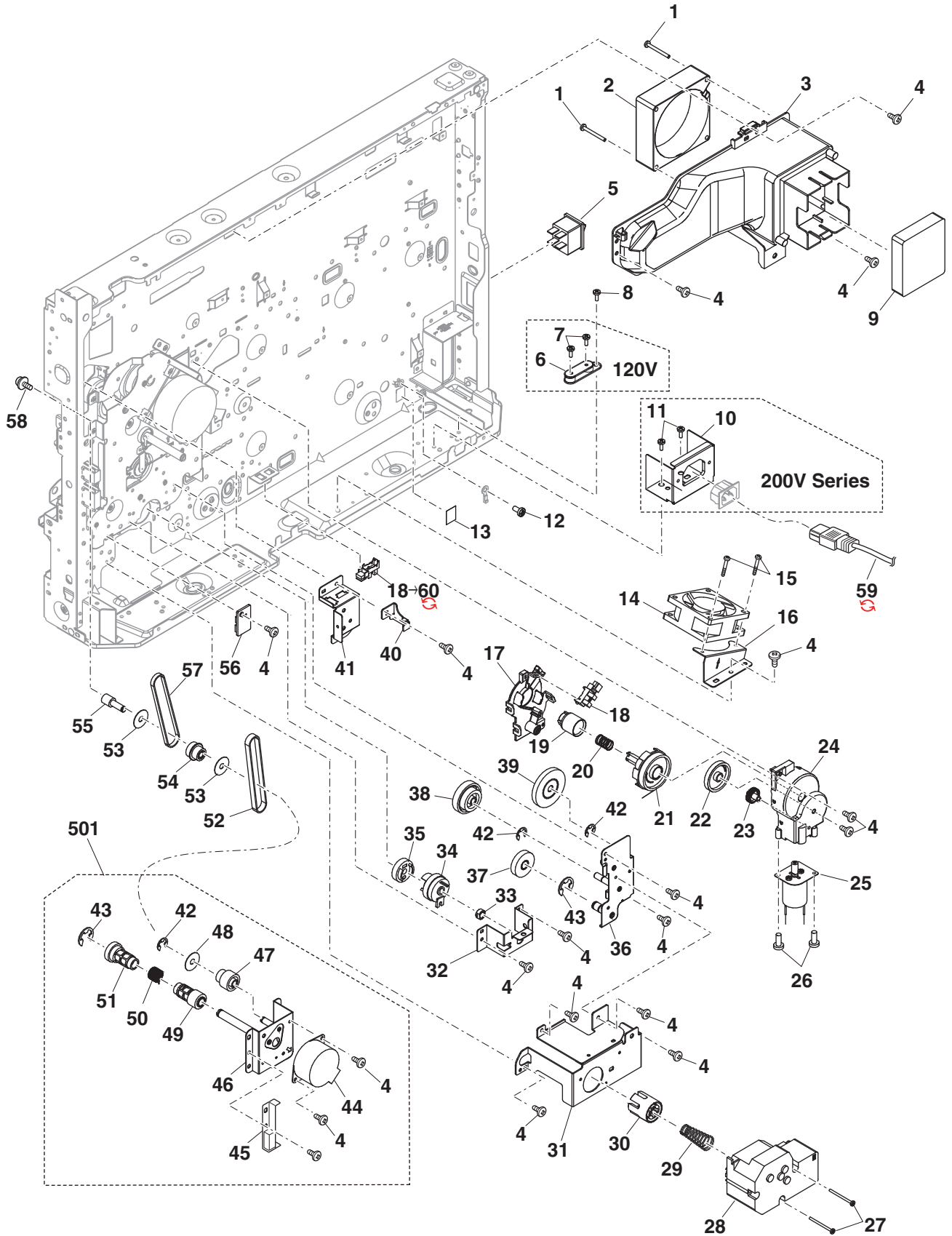

30 フレームセクション 3(Frame section 3)[AR-6023N,AR-6023NR,AR-X231N,AR-6020N, AR-6020NR,AR-6120N,AR-6023D,AR-6020D,AR-X201D,AR-6023,AR-6020,AR-X201]

NO.	PARTS CODE	Inter-change	PRICE Ex.	RANK Ja.	NEW MARK	PART RANK	DESCRIPTION	Reason for change	Effective time	
1	NFANP0127FCPZ		AW	FG		B	Power supply fan	電源ファン		
2	PDUC-0029QSZZ		AP	EQ	N	C	Fan duct outside	ファンダクト外		
3	LX-BZ0030QSPZ		AC	DD		C	Fan fixing screw	ファン固定ビス		
4	XHBS730P06000		AC	DD		C	Screw(3x6)	ビス		
5	XHBS740P08000		AA	DD		C	Screw(4x8)	ビス		
6	XBPSN40P06K00		AA	DD		C	Screw(4x6)	ビス		
7	VHPSG2A141+-1	1	AF	DS		B	Photo sensor(SG2A141)	フォトセンサー	Productivity improvement	15/Jun
8	PCOVP0218QSZZ		AE	DS	N	C	TN drive cover	TN 駆動カバー		
9	VHPSG2A241+-1	1			N	B	Photo sensor(SG2A241)	フォトセンサー	Productivity improvement	15/Jun
10	NCPL-0032QSZZ		AD	DD	N	C	TN drive coupling	TN 駆動カップリング		
11	MSPRC0605QSZZ		AC	DD	N	C	Drive spring	駆動スプリング		
12	NGERH0404QSZZ		AE	DJ	N	C	Gear(77T)	ギヤ		
13	NGERH0403QSZZ		AD	DJ	N	C	Gear(79/20T)	ギヤ		
14	NGERH0402QSZZ		AD	DJ	N	C	Gear(29/11T)	ギヤ		
15	PBOX-0032QSZZ		AF	DS	N	C	TN drive box	TN 駆動ボックス		
16	DUNT-1220RS51		AV	FG	N	E	TN motor unit	TN モーターユニット		
17	XEBS730P08000		AC	DD		C	Screw(3x8)	ビス		
18	XPSSJ30-18000		AB	DD		C	Spring pin(φ3-18)	スプリングピン		
19	XRSP50-06000		AA	DD		C	E type ring(E5)	E リング		
20	NBRGM0501FCZZ		AB	DJ		C	Bearing N(f6)	軸受 N		
21	NSFTZ0185QSZZ		AF	DS	N	C	Paper feed drive shaft	給紙駆動シャフト		
21	NSFTZ0185QSZ1	3			N	C	Paper feed drive shaft	給紙駆動シャフト	Improve performance	14/Dec RC
22	LPLTM0808QSZZ		AG	DX	N	C	Clutch fixing plate	クラッチ固定板		
23	PCLC-0373FCZ1		AP	EQ		B	Clutch(2.5KG)	クラッチ		
24	XRSP40-06000		AA	DD		C	E type ring(E4)	E リング		
25	XRSP70-08000		AA	DD		C	E type ring(E7)	E リング		
26	NGERH0418QSZZ		AE	DJ	N	C	DUP reduction gear(22T)	DUP 減速ギヤ		
27	MSPRC1315FCZ1		AD	DJ		C	Manual paper feed clutch spring A	手差しクラッチスプリング A		
28	NGERH0439QSZZ		AD	DJ	N	C	DUP reduction gear(31T)	DUP 減速ギヤ		
29	CPLTM0761QS01		AM	EG	N	C	DUP drive plate assy	DUP 駆動板アセン		
30	NPLYZ0057QSZZ		AD	DJ	N	C	Gear(35-22T)	ギヤ		
31	LX-WZ0002QSZ1		AB	DD		C	PO belt washer	POベルトワッシャー		
32	RMOTS0093QSPZ		AY	FQ	N	B	DUP motor	DUP モーター		
33	NBLTH0551FCZZ		AR	EQ		B	DV transmission belt CL	DV 伝達ベルト CL		
34	NBLTT0026QSZZ		AF	DS		B	DUP drive belt	DUP 駆動ベルト		
35	LX-WZ0460FCZZ		AC	DD		C	Flange sheet(φ6-20)	フランジマイラー		
36	NPLYZ0058QSZZ		AD	DJ	N	C	Delivery drive gear(26-22T)	排紙駆動ギヤ		
37	NSFTZ0197QSZZ		AF	DS	N	C	DUP drive shaft	DUP 駆動シャフト		
38	NBLTT0024QSZZ		AG	DS		B	Drive belt [AR-6023,AR-6020,AR-X201,AR-G200]	駆動ベルト		
39	LPLTM0757QSZZ		AF	DS	N	C	Power supply inlet plate [200V Series]	電源インレット板		
40	TLABZ4868FCZ1		AB	DJ		D	Earth label [200V Series]	アースラベル		
41	QSW-C9295QCPZ		AL	EB		B	Main power switch	メイン電源スイッチ		
42	XBPS740P08K00		AB	DD		C	Screw(4x8K)	ビス		
43	DHAi-3332DS11		BB	GD		B	AC cord(Refer to Matrix)	ACコード		
43	QACCBR628QCPZ		AX	FX		B	AC cord(Refer to Matrix)	ACコード		
43	QACCBR628QCP1	3	BA	FX		B	AC cord(Refer to Matrix)	ACコード	Specification change	15/Apr
43	QACCDR412QCPZ		BL	HG		B	AC cord(Refer to Matrix)	ACコード		
43	QACCER625QCPZ		AQ	EQ		B	AC cord(Refer to Matrix)	ACコード		
43	QACCJR717QCPZ		BH	GX	N	B	AC cord(Refer to Matrix)	ACコード		
43	QACCLR628QCPZ		BL	HL	N	B	AC cord(Refer to Matrix)	ACコード		
43	QACCZR412QCPZ		BL	HL		B	AC cord(Refer to Matrix)	ACコード		
43	QACCZR628QCPZ		AU	EZ	N	B	AC cord(Refer to Matrix)	ACコード		
43	QACCZR674QCPZ		BH	HC		B	AC cord(Refer to Matrix)	ACコード		
43	QACCZR72GQCPZ		BK	HC		B	AC cord(Refer to Matrix)	ACコード		
43	QACCZR922QCPZ		BK	HG		B	AC cord(Refer to Matrix)	ACコード		
43	QACCER625QCP1	3	AQ	EQ		B	AC cord(Refer to Matrix)	ACコード	Specification change	15/Mar
44	XBBS740P08000		AA	DD		C	Screw(4x8) [200V Series]	ビス		
45	PfiLZ0038QSZZ		AU	FG	N	B	Ozone filter	オゾンフィルター		
45	PfiLZ0041QSZZ	-	AU	FG	N	A	Ozone filter	オゾンフィルター	Parts code correction	1st lot
46	LPLTM0840QSZZ		AE	DJ	N	C	Fusing connector fixing plate	定着コネクタ取付板		
47	LPLTM0887QSZZ		AD	DD		C	Fusing support plate	定着支持板		
48	PSHEZ0905QSZZ	-	AG	DX	N	C	HT harness protect sheet	HTルーネ保護シート	Missing parts code	1st lot
54	LfiX-0016FCZZ		AD	DJ		C	AC cord fixture [100V,110V,120V]	ACコード押え		
55	XBPS740P20XS0		AC	DD		C	Screw(4x20) [100V,110V,120V]	ビス		
62	QSW-C9294QCZZ		AF	DS		B	Dehumidification heater switch [Japan(日本)]	除湿ヒータースイッチ		
501	CPLTM0808RS51		AW	FG	N	E	Paper feed drive unit	給紙駆動ユニット		
501	CPLTM0808RS52	-	AU	EZ	N	E	Paper feed drive unit	給紙駆動ユニット	Parts code correction	1st lot
502	CPLTM0761RS51		AZ	FX	N	E	DUP drive unit	DUP 駆動ユニット		

30 フレームセクション 3(Frame section 3)[AR-6023N,AR-6023NR,AR-X231N,AR-6020N,AR-6020NR,AR-6120N,AR-6023D,AR-6020D,AR-X201D,AR-6023,AR-6020,AR-X201]

NO.	PARTS CODE	Inter-change	PRICE RANK		NEW MARK	PART RANK	DESCRIPTION	Reason for change	Effective time
			Ex.	Ja.					
502	⊗ CPL TM0761RS54	-	BA	FX	N	E	DUP drive unit DUP 駆動ユニット	Parts code correction	1st lot

Matrix

No.43		ACコード (AC cord)											
PARTS CODE	Americas1	Europe Asia6 Asia10	Australia	Thailand	India	HongKong	Asia2	Asia3	Asia4	Taiwan	Brazil	SouthAfrica Namibia	Japan(日本)
DHA i - 3332DS11													1st Lot
QACCBR628QCPZ						1st Lot			1st Lot				
⊗ QACCBR628QCP1							1st Lot		15/Apr				
QACCDR412QCPZ	1st Lot												
QACCER625QCPZ		1st Lot											
QACCJR717QCPZ													1st Lot
QACCLR628QCPZ			1st Lot										
QACCZR412QCPZ										1st Lot			
QACCZR628QCPZ								1st Lot					
QACCZR674QCPZ					1st Lot								
QACCZR72GQCPZ											1st Lot		
QACCZR922QCPZ				1st Lot									
⊗ QACCER625QCP1		15/Mar											

30 フレームセクション 3(Frame section 3)[AR-6023N,AR-6023NR,AR-X231N,AR-6020N,AR-6020NR,AR-6120N,AR-6023D,AR-6020D,AR-X201D,AR-6023,AR-6020,AR-X201]

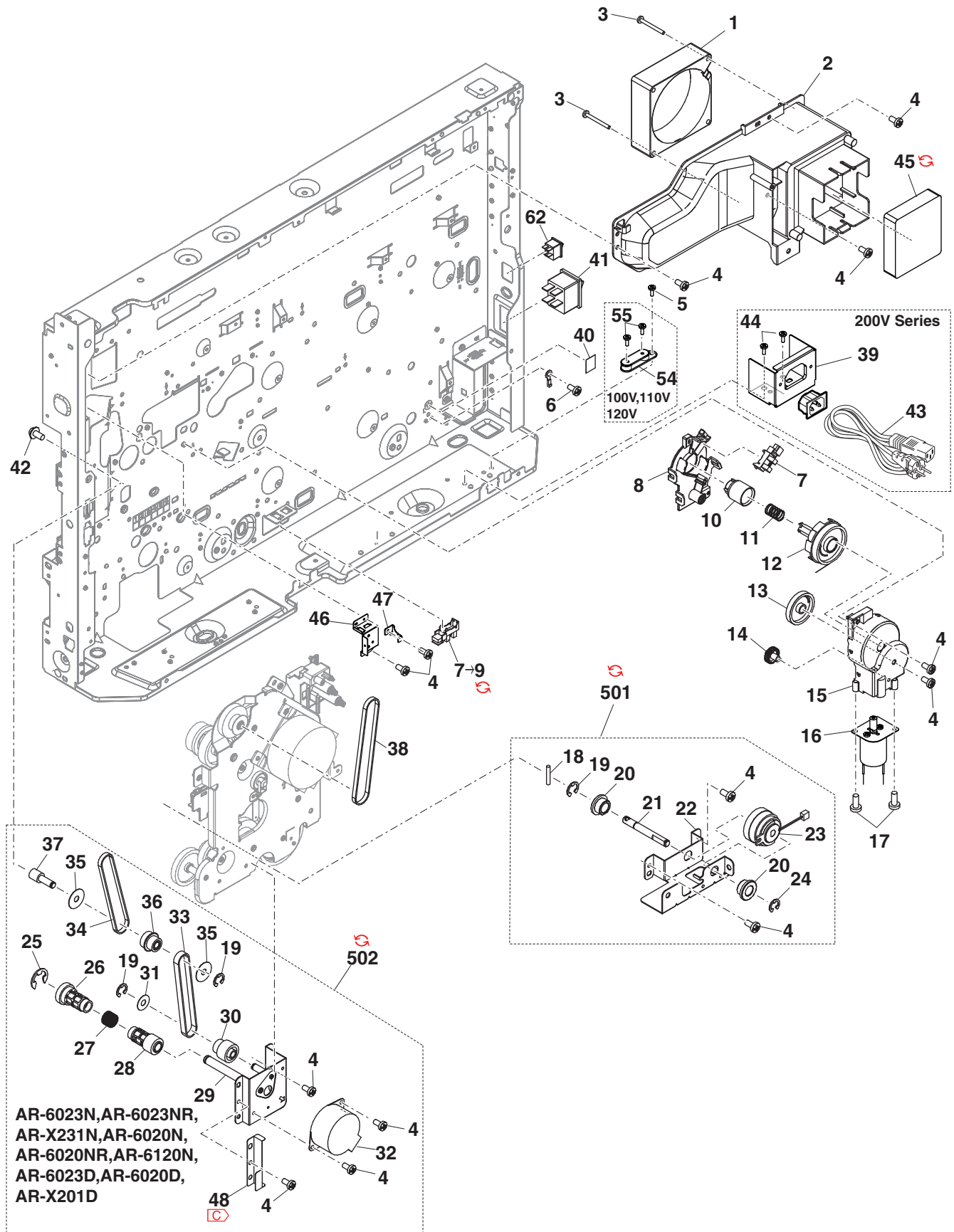



31 フレームセクション4(Frame section 4)

Matrix

No.1-1		MCU基板 (MCU PWB)								
PARTS CODE	Americas1,Europe Asia1,Asia2,Asia3 Asia4,Asia6 SouthAfrica,Namibia		Taiwan	Asia10	Americas1,Europe Asia1,Brazil SouthAfrica,Namibia	Taiwan	Americas1,Europe Asia1,Asia2,Asia3 Asia4,Asia6 SouthAfrica,Namibia	AR-6023N AR-6023NR	AR-X231N	AR-6020N AR-6020NR AR-6120N
	CPWBX0301QS39	AR-6031N AR-6031NR AR-6131N								
CPWBX0301QS3C								1st Lot		
CPWBX0301QS3D				1st Lot						
CPWBX0301QS3G								1st Lot		
CPWBX0301QS3H							1st Lot			
CPWBX0301QS3i			1st Lot							
CPWBX0301QS45										1st Lot
CPWBX0301QS46					1st Lot					
CPWBX0301QS47	1st Lot									

No.1-2		MCU基板 (MCU PWB)								
PARTS CODE	Europe Australia Asia		Taiwan	Americas,Europe Australia,Asia1,Asia2 Asia4,Asia6 SouthAfrica,Namibia	Asia10	Europe,Asia SouthAfrica,Namibia	Europe,Asia1,Asia2 Asia3,Asia4,Asia6 SouthAfrica,Namibia	AR-6020	AR-X201	AR-G200
	CPWBX0301QS38	AR-6023D								
CPWBX0301QS3A									1st Lot	
CPWBX0301QS3B					1st Lot					
CPWBX0301QS3E								1st Lot		
CPWBX0301QS3F			1st Lot							
CPWBX0301QS42						1st Lot				
CPWBX0301QS43					1st Lot					
CPWBX0301QS44		1st Lot								
CPWBX0301QS48										1st Lot

No.3		USB I/F基板 (USB interface PWB)		
PARTS CODE	Americas1 Europe Australia HongKong Asia3 Asia4 Asia6 Asia10 Japan(日本)		Thailand India SouthAfrica Namibia Taiwan	Asia2
	CPWBN0219QS31		1st Lot	
CPWBN0219QSC1			1st Lot	
CPWBN0315QSE1				1st Lot

No.7		NNB基板ユニット (NNB PWB unit)			
PARTS CODE	Americas1 Europe1 Europe2 Australia Asia1 Asia2 Asia3 Asia4 Asia6 SouthAfrica Namibia Brazil		Europe3 Asia10	Taiwan	Japan(日本)
	CPWBX0306RS52		1st Lot		
CPWBX0306RS53					1st Lot
CPWBX0306RS54			1st Lot		
CPWBX0306RS56				1st Lot	

31 フレームセクション 4(Frame section 4)

No.8		低圧電源 (Low voltage power supply)			
PARTS CODE	AR-6031N AR-6031NR AR-6131N AR-X311N AR-6026N AR-6026NR		AR-6023N AR-6023NR AR-X231N AR-6020N AR-6020NR AR-6120N AR-6023D AR-6020D AR-X201D AR-6023 AR-6020 AR-X201 AR-G200		
	120V 110V	200V series	120V 110V 100V	200V series	
RDENC0085QSPZ				1st Lot	
RDENC0085QSP1				14/DEC RC	
RDENC0089QSPZ			1st Lot		
RDENC0090QSPZ	1st Lot				
RDENC0091QSPZ		1st Lot			



31 フレームセクション4(Frame section 4)

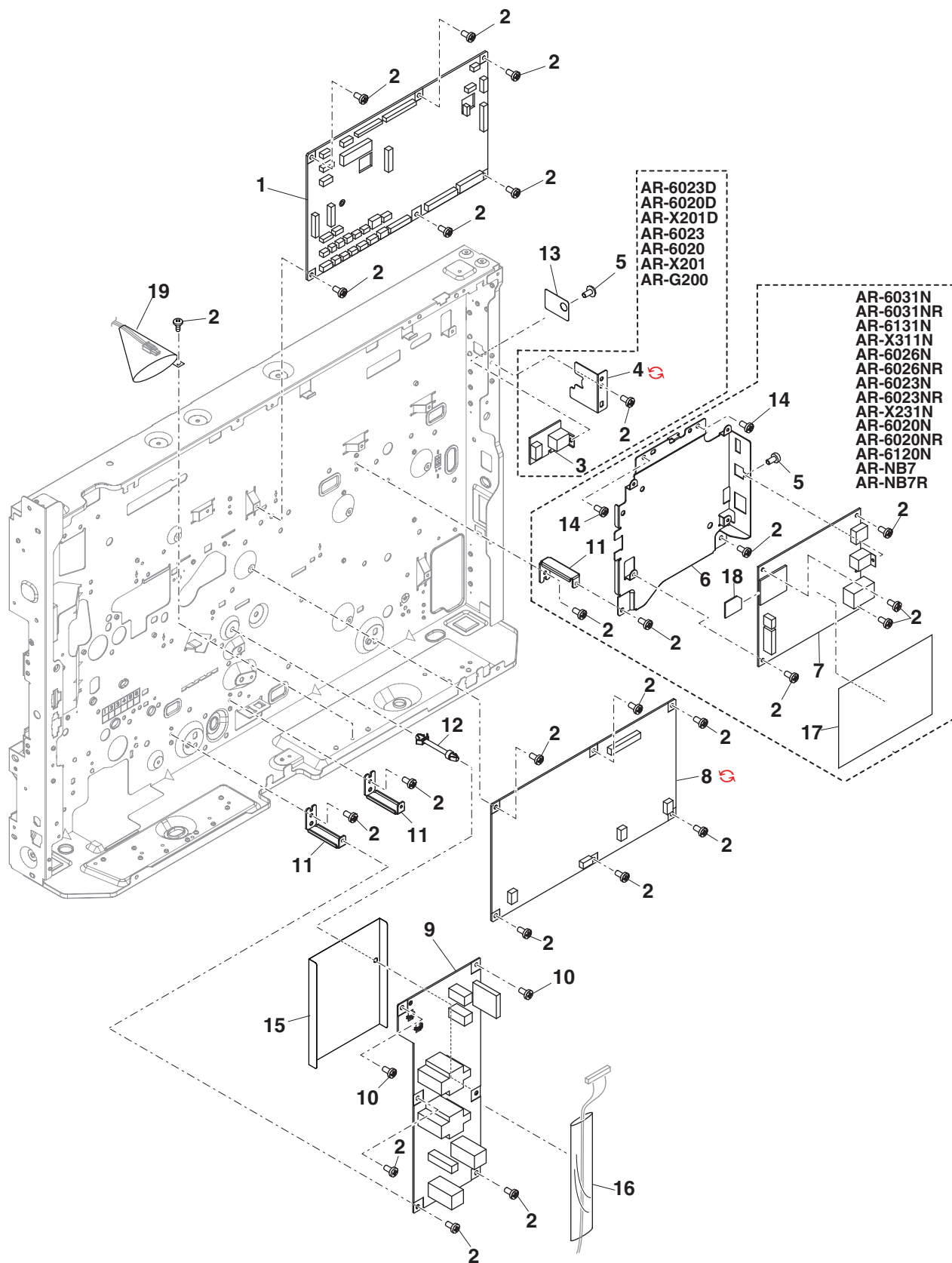

32 ハーネス部 (Harness section)

NO.	PARTS CODE	Inter-change	PRICE Ex.	RANK Ja.	NEW MARK	PART RANK	DESCRIPTION	Reason for change	Effective time
1	DHA i-0796QSPZ		AF	DS	N	C	Paper feed clutch harness 給紙クワッチハーネス		
2	DHA i-0793QSPZ		AM	EG	N	C	P-IN sensor harness P-IN センサーハーネス		
3	DHA i-0790QSPZ		AL	EB	N	C	Main motor harness メインモーターハーネス		
4	DHA i-0797QSPZ		AF	DS	N	C	PS clutch harness PS クワッチハーネス		
5	DHA i-0863QSPZ		AG	DX	N	C	Paper width detection sensor harness 紙幅検知センサーハーネス		
6	DHA i-0795QSPZ		AG	DS		C	Manual paper feed paper feed clutch harness 手差し給紙クワッチハーネス		
7	DHA i-0832QSPZ		AG	DX	N	C	Manual paper feed detect sensor harness 手差し検知センサーハーネス		
8	DHA i-0859QSPZ		AG	DX	N	C	Intake fan interface harness 吸気ファン中継ハーネス		
9	DHA i-0848QSPZ		AR	EQ	N	C	POUT interface harness POUT 中継ハーネス		
	DHA i-0841QSPZ		AH	DX	N	C	POSD harness POSD ハーネス		
10	DHA i-0841QSP1	3	AH	DX	N	C	POSD harness POSD ハーネス	Productivity improvement	14/DEC RC
11	CHA i-0803RS51		AL	EB	N	C	MC high voltage harness assy MC 高圧ハーネスアッセンブリ		
12	DHA i-0804QSPZ		AG	DX	N	C	TC high voltage harness TC 高圧ハーネス		
13	DHA i-0822QSPZ		AG	DX	N	C	DHV harness DHV ハーネス		
14	DHA i-0799QSPZ		AM	EG	N	C	PS harness(Refer to Matrix) PS ハーネス		
	DHA i-0849QSPZ		AP	EQ	N	C	Power supply harness(Refer to Matrix) 電源ハーネス		
15	DHA i-0825QSPZ		AK	DX	N	C	MCU TO HV harness MCU TO HV ハーネス		
16	DHA i-0808QSPZ		AG	DX	N	C	ATC sensor harness(Refer to Matrix) ATC センサーハーネス		
	DHA i-0909QSPZ		AG	DX	N	C	ATC sensor harness(Refer to Matrix) ATC センサーハーネス		
17	DHA i-0847QSPZ		AK	DX	N	C	ATC sensor interface harness(Refer to Matrix) ATC センサー中継ハーネス		
	DHA i-0910QSPZ		AK	EB	N	C	ATC sensor interface harness(Refer to Matrix) ATC センサー中継ハーネス		
18	DHA i-0801QSPZ		AL	EB	N	C	CRAM harness クラムハーネス		
19	DHA i-0843QSPZ		AH	DX	N	C	LED harness LED ハーネス		
20	DHA i-0844QSPZ		AG	DX	N	C	SCAN MOTOR harness SCAN MOTOR ハーネス		
21	DHA i-0845QSPZ		AG	DS	N	C	Original detect sensor harness 原稿検知センサーハーネス		
22	DHA i-0813QSPZ		AL	EB	N	C	CCD FFC CCD FFC		
23	DHA i-0842QSPZ		AG	DS	N	C	CL FFC harness CL FFC ハーネス		
24	DHA i-0823QSPZ		AQ	EQ	N	C	HL harness HL ハーネス		
25	DHA i-4729FCP1		BD	GN		C	Inlet unit harness [200V Series] イレットユニットハーネス		
26	DHA i-0565QSPZ		AP	EQ		C	AC-SW harness AC-SW ハーネス		
27	DHA i-0829QSPZ		AH	DX	N	C	USB-MCU harness USB-MCU ハーネス		
28	DHA i-0827QSPZ		AM	EG	N	C	NNB-MCU harness NNB-MCU ハーネス		
29	DHA i-0826QSPZ		AG	DX	N	C	NNB(USB)-MCU harness NNB(USB)-MCU ハーネス		
30	DHA i-0789QSPZ		AS	EQ	N	C	LSU harness LSU ハーネス		
31	DHA i-0814QSPZ		AQ	EQ	N	C	OPE FFC OPE FFC		
32	DHA i-0850QSPZ		AH	DX	N	C	Brush motor harness ブラシモーターハーネス		
33	DHA i-0853QSPZ		AH	DX	N	C	Temperature-humidity sensor harness [AR-6031N,AR-6031NR,AR-6131N,AR-X311N,AR-6026N,AR-6026NR] 温湿度センサーハーネス		
34	DHA i-0866QSPZ		AG	DS	N	C	Temperature sensor harness 温度センサーハーネス		
35	DHA i-0870QSPZ		AL	EB	N	C	LSU fan interface harness LSU ファン中継ハーネス		
36	DHA i-0798QSPZ		AH	DX	N	C	Power supply fan harness 電源ファンハーネス		
39	DHA i-0864QSPZ		AW	FG	N	C	HEAT LAMP harness HEAT LAMP ハーネス		
40	DHA i-0570QSP2		AZ	FQ		C	DH-PS harness [Japan(日本)] DH-PS ハーネス		
	DHA i-0852QSPZ	-	AT	EZ	N	C	DHR harness [Japan(日本)] DHR ハーネス	Parts code correction	1st lot
41	DHA i-0838QSPZ		AU	EZ		C	Cassette sensor harness カセットセンサーハーネス		
42	DHA i-0816QSPZ		AF	DS		C	Cassette detect sensor harness カセット検知センサーハーネス		
43	DHA i-0856QSPZ		AF	DS		C	LUM harness LUM ハーネス		
44	DHA i-0821QSPZ		AY	FQ		C	Cassette harness カセットハーネス		
45	DHA i-0794QSPZ		AP	EQ	N	C	Cassette detect sensor harness カセット検知センサーハーネス		
46	DHA i-0792QSPZ		AG	DX	N	C	Paper detect sensor harness 紙検知センサーハーネス		
47	DHA i-0906QSPZ		AH	DX	N	C	P-IN sensor harness [AR-6031N,AR-6031NR,AR-6131N,AR-X311N,AR-6026N,AR-6026NR] P-IN センサーハーネス		
48	DHA i-0913QSPZ				N	C	Manual paper feed clutch interface harness [Japan(日本)] 手差しクワッチ中継ハーネス		
49	DHA i-3837FCZZ		AC	DJ		C	Read plate earth harness 読取板アースハーネス		
50	DHA i-4734FCPZ		BE	GN		C	RSPF original tray harness RSPF 原稿トレイハーネス		
51	DHA i-0836QSPZ		AL	EB	N	C	RSPF SPPD4 harness RSPF SPPD4 ハーネス		
52	DHA i-4414FCPZ		AP	EQ		C	SPF transport harness SPF 搬送ハーネス		
53	DHA i-4731FCPZ		BE	GN		C	RSPF interface harness RSPF 搬送中継ハーネス		
54	DHA i-0834QSPZ		AH	DX	N	C	RSPF clutch solenoid interface harness RSPF クワッチリフト中継ハーネス		
55	DHA i-4733FCPZ		BE	GN		C	RSPF paper feed harness RSPF 給紙ハーネス		
56	DHA i-0835QSPZ		BA	FX	N	C	RSPF interface harness RSPF 中継ハーネス		

32 ハーネス部 (Harness section)

Matrix

No.14		PSハーネス (PS harness)	
PARTS CODE	AR-6031N AR-6031NR AR-6131N AR-X311N AR-6026N AR-6026NR	AR-6023N AR-6023NR AR-X231N AR-6020N AR-6020NR AR-6120N AR-6023D AR-6020D AR-X201D AR-6023 AR-6020 AR-X201 AR-G200	
DHA i - 0799QSPZ			1st Lot
DHA i - 0849QSPZ	1st Lot		

No.16		ATCセンサーハーネス (ATC sensor harness)	
PARTS CODE	AR-6031N AR-6031NR AR-6131N AR-X311N AR-6026N AR-6026NR	AR-6023N AR-6023NR AR-X231N AR-6020N AR-6020NR AR-6120N AR-6023D AR-6020D AR-X201D AR-6023 AR-6020 AR-X201 AR-G200	
DHA i - 0808QSPZ			1st Lot
DHA i - 0909QSPZ	1st Lot		

No.17		ATCセンサー中継ハーネス (ATC sensor interface harness)	
PARTS CODE	AR-6031N AR-6031NR AR-6131N AR-X311N AR-6026N AR-6026NR	AR-6023N AR-6023NR AR-X231N AR-6020N AR-6020NR AR-6120N AR-6023D AR-6020D AR-X201D AR-6023 AR-6020 AR-X201 AR-G200	
DHA i - 0847QSPZ			1st Lot
DHA i - 0910QSPZ	1st Lot		

32 ハーネス部 (Harness section)

ファン, センサー, モーター, クラッチ (FAN, Sensor, Motor, Clutch)

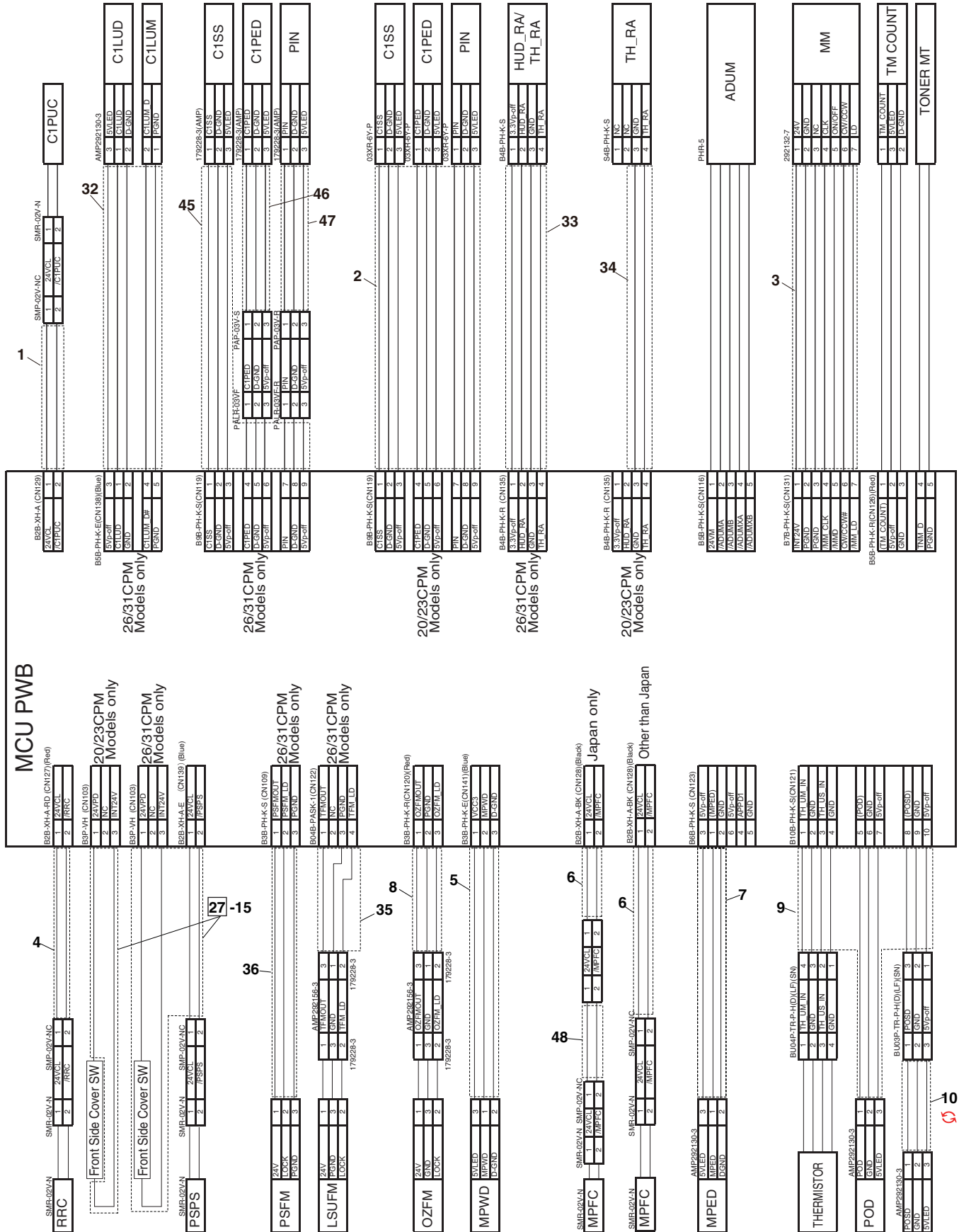

32 ハーネス部 (Harness section)

DC 電源 , 高圧基板 , 現像 (DC power supply, High voltage PWB, DV)

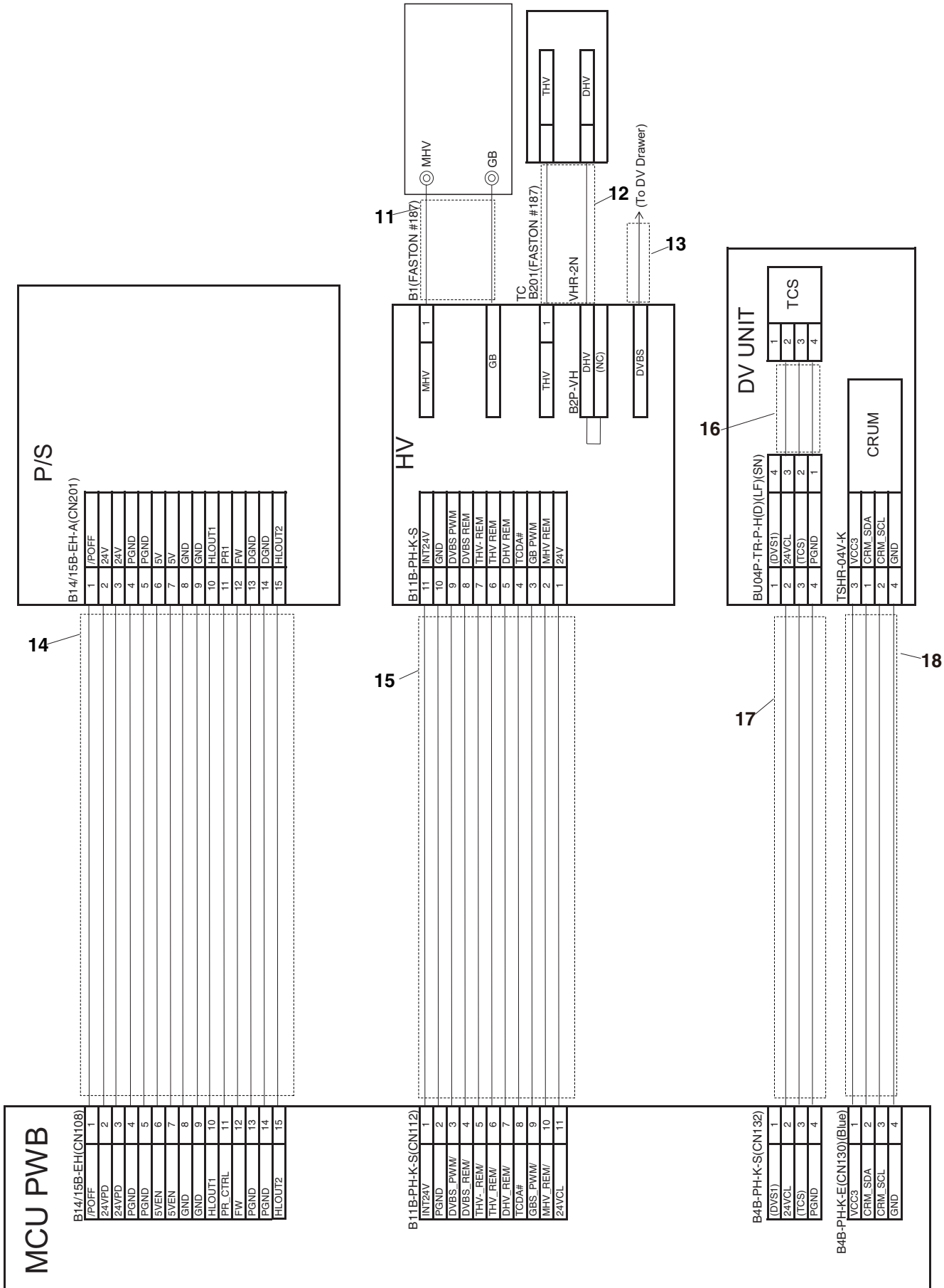

32 ハーネス部 (Harness section)

スキャナ (Scanner)

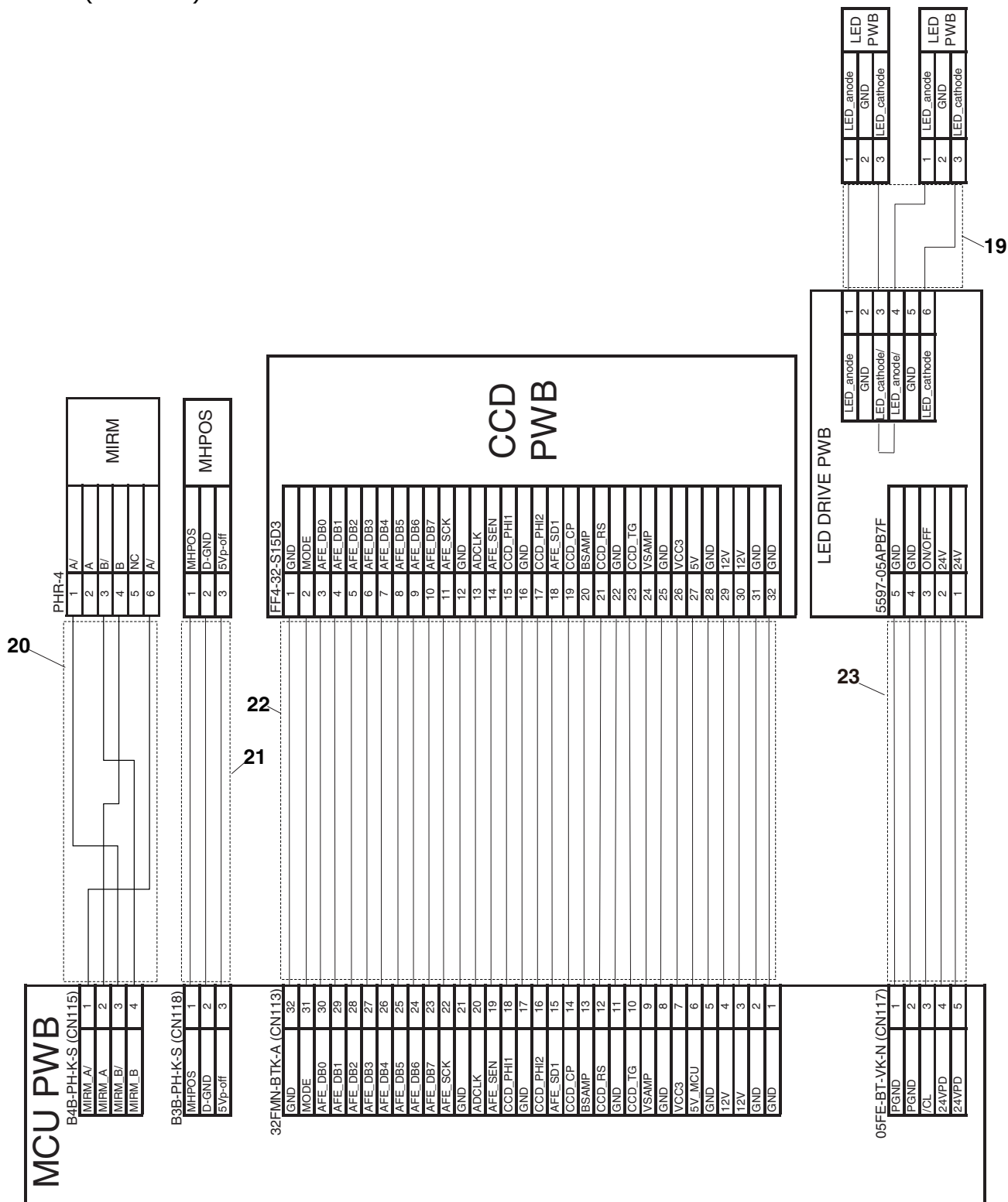

32 ハーネス部 (Harness section)

AC電源 (AC power supply)

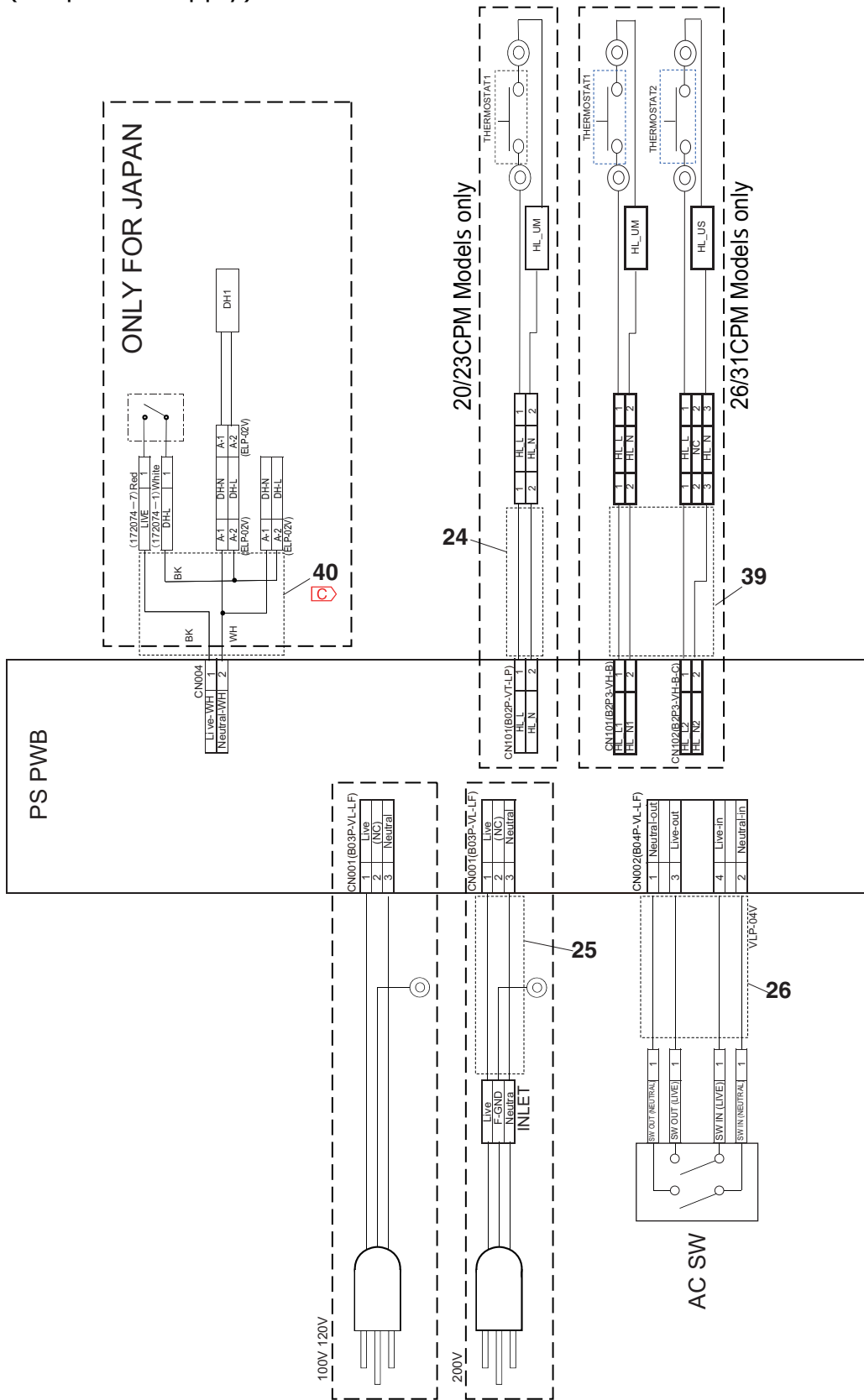

32 ハーネス部 (Harness section)

LSU, 操作パネル, ネットワーク基板 (LSU, Operation panel, Network PWB)

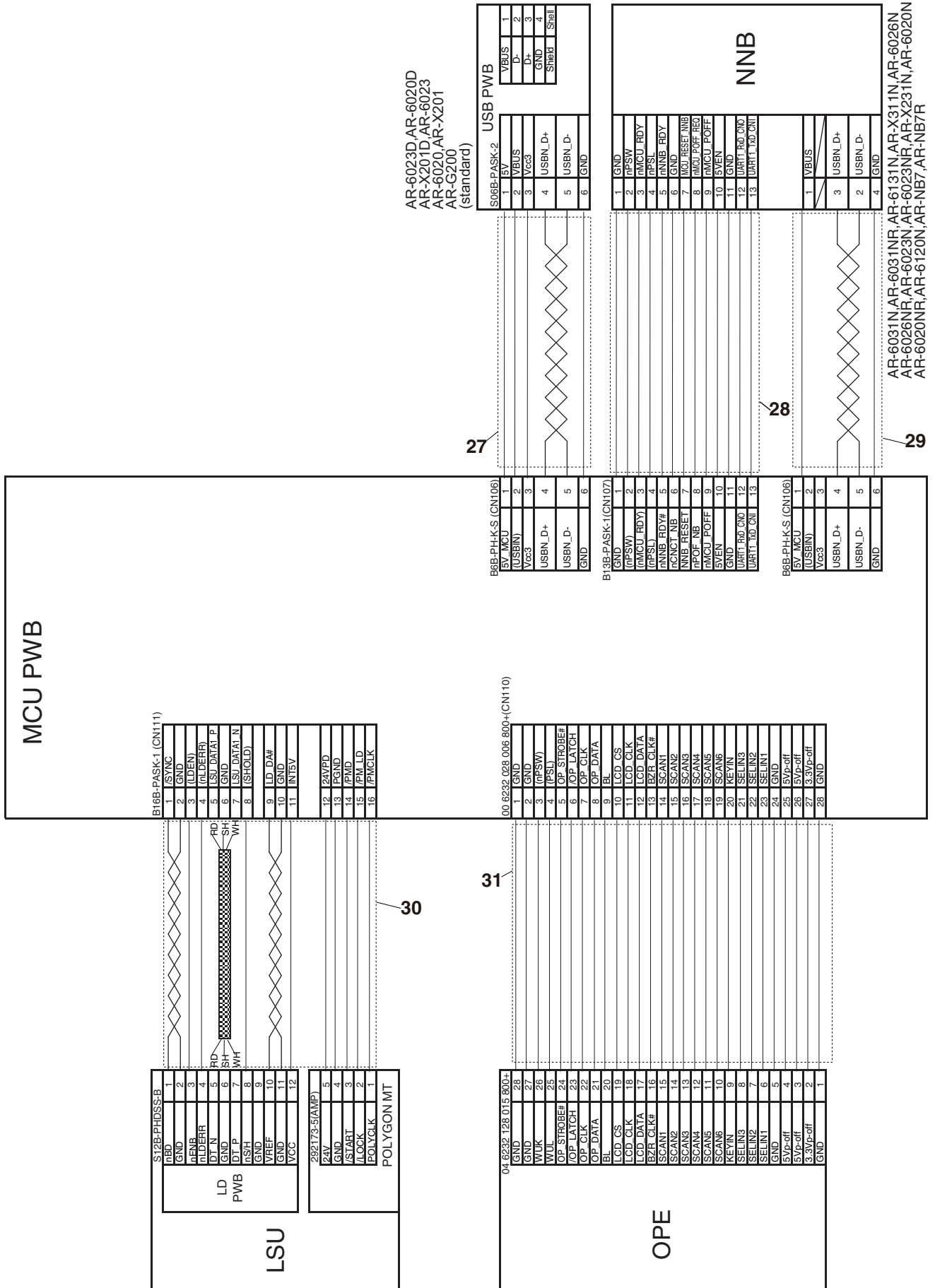



32 ハーネス部 (Harness section)

セカンドトレイ (2nd tray)

AR-6031N,AR-6031NR,AR-6131N  
AR-X311N,AR-6026N,AR-6026NR  
Tray 2 unit

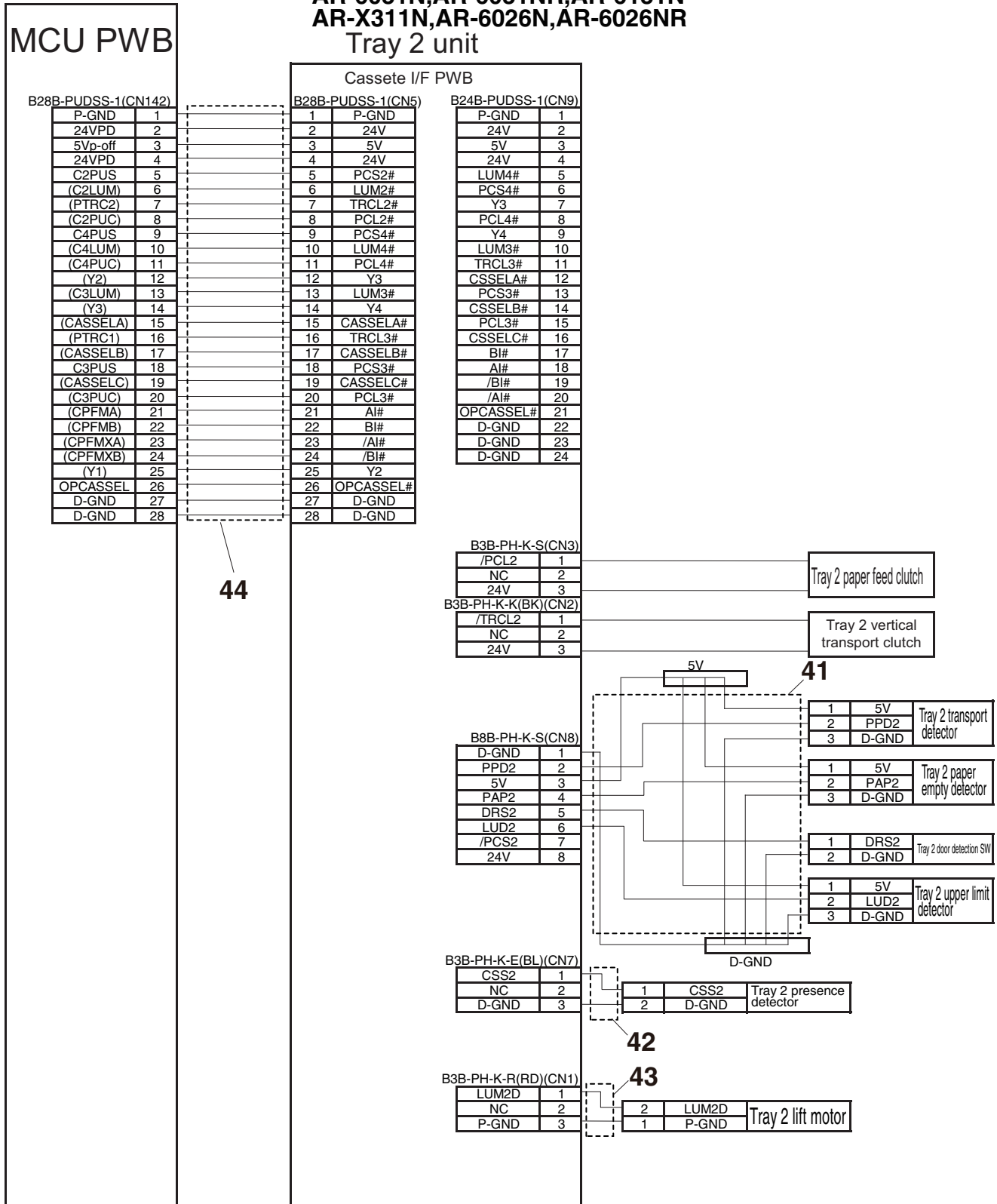

32 ハーネス部 (Harness section)

RSPF[AR-RP11]

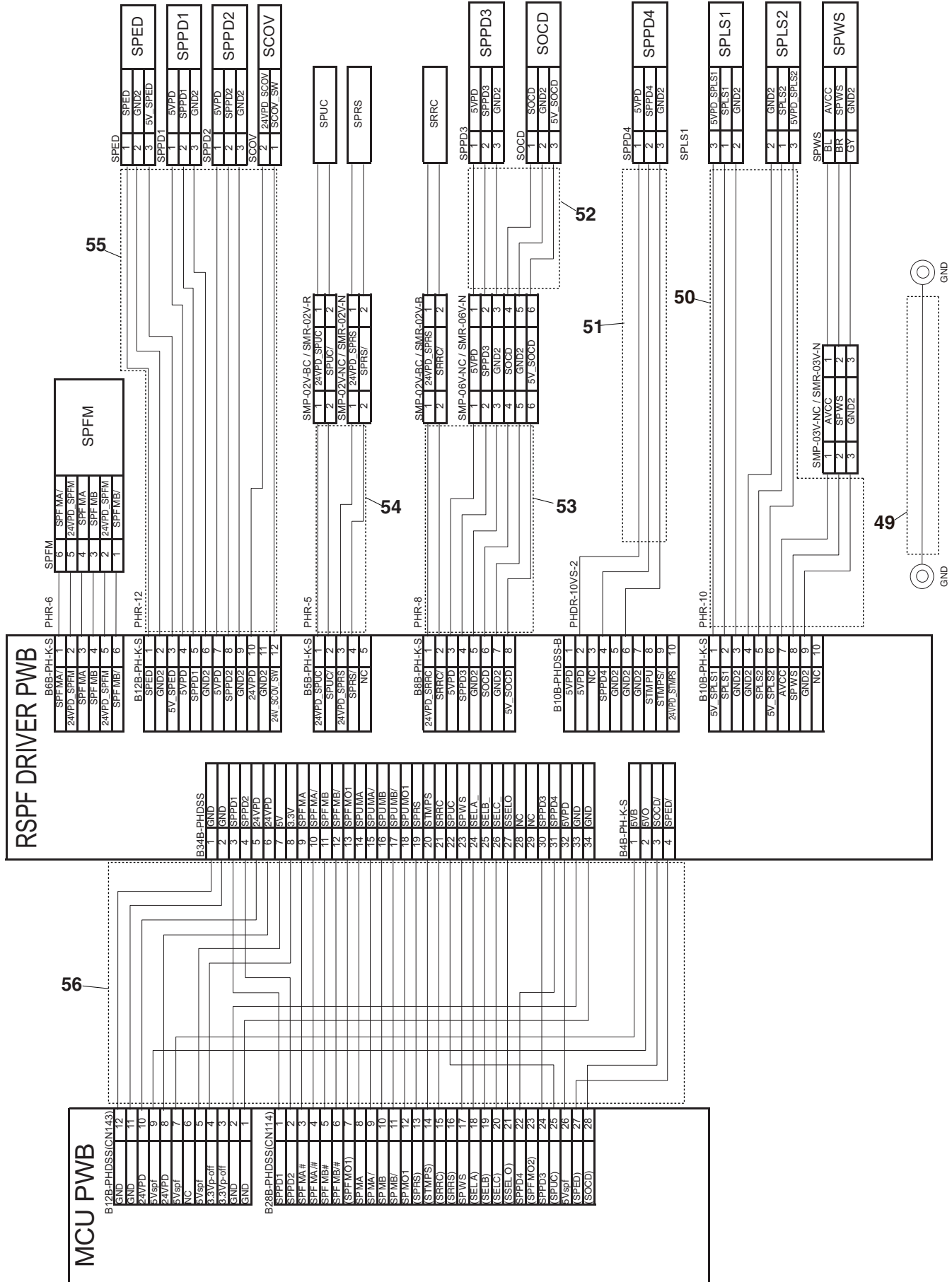

33 ワイヤースドル・クランプ (Wire saddle, Clamp)

NO.	PARTS CODE	Inter-change	PRICE RANK		NEW MARK	PART RANK	DESCRIPTION		Reason for change	Effective time
			Ex.	Ja.						
1	LBNDJ0037FCZ1		AA	DJ		C	Band(T18S)	バンド		
2	LBNDJ0071FCZZ		AC	DJ		C	Band(RSG-100)	バンド		
3	LBNDJ0099FCPZ		AC	DJ		C	Clamp(N-4)	ナイロンクランプ		
4	<input checked="" type="checkbox"/> LHLDW0279QSZZ		AD	DJ		C	Harness lifter(HL28)	ハーネスリフター	Productivity improvement	1st lot
5	LHLDW1620FCZZ		AC	DJ		C	Edge holder(11U)	エッジホルダー		
6	LHLDW2038FCPZ		AC	DJ		C	Clamp(RMS-2)	クランプ		
7	LHLDW2328FCPZ		AC	DD		C	Edge saddle(EWSE-8.1-01)	エッジサドル		
8	LHLDW2377FCPZ		AC	DD		C	Wire saddle(GRBWS-1212E)	ワイヤースドル		
9	LHLDW2378FCPZ		AC	DD		C	Wire saddle(GRBWS-1416E)	ワイヤースドル		
10	LHLDW1285FCZZ		AC	DJ		C	Edge saddle(EH11)	エッジサドル		
11	LHLDW0086QSZZ		AB	DJ	N	C	Harness ring(2×6)	ハーネスリング		
12	LHLDW1757FCPZ		AC	DJ		C	Wire saddle	ワイヤースドル		
13	RCORF0018QSZZ		AR	EQ		C	Ferrite core	フェライトコア		
14	LHLDW2037FCPZ		AC	DJ		C	Clamp(RMS-1V0)	クランプ		
15	LHLDW1970FCPZ		AH	DX		C	Harness clamp(RMS-3V0)	ハーネスクランプ		
16	LHLDW1057FCZZ		AB	DD		C	Wire saddle(LWS35)	ワイヤースドル		
17	LHLDW1263FCZZ		AC	DJ		C	Edge saddle(EDS0607M)	エッジサドル		
18	LHLDW1489FCZZ		AC	DJ		C	Wire saddle	ワイヤースドル		
19	RCORF0021QSZZ		AK	DX		C	Core	コア		
20	RCORF0034QSZZ		AF	DS	N	C	Core(GSSC-40-12)	コア		

33 ワイヤースドル・クランプ (Wire saddle, Clamp)

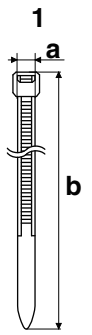

a : 80mm  
b : 4.2mm

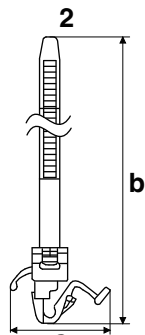

a : 16.2mm  
b : 100mm

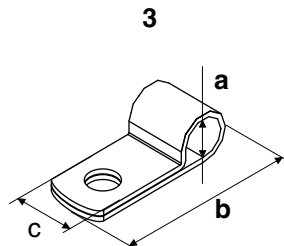

a : 6.8mm  
b : 23.7mm  
c : 11.1mm

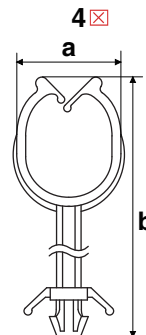

a : 18mm  
b : 51.7mm

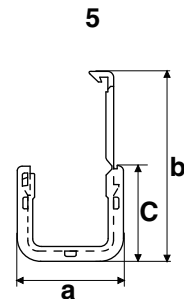

a : 18mm  
b : 31.4mm  
C : 11.1mm

6

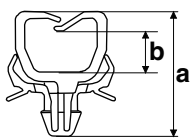

a : 14.8mm  
b : 6.2mm

7

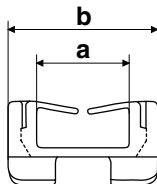

a : 5.0mm  
b : 11.3mm

8

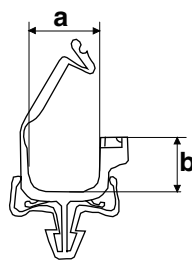

a : 12mm  
b : 12mm

9

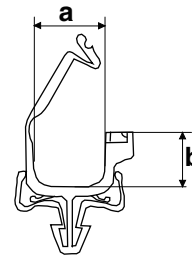

a : 16mm  
b : 14mm

10

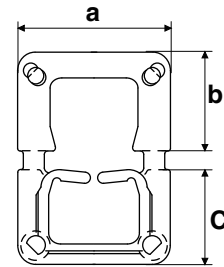

a : 18.4mm  
b : 11.8mm  
C : 11.2mm

11

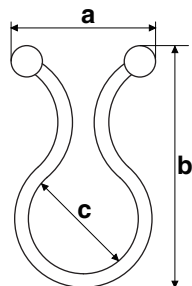

a : 22mm  
b : 35mm  
c : 15mm

12

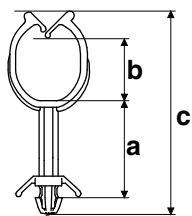

a : 19.5mm  
b : 13.8mm  
C : 41.7mm

13

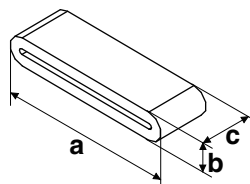

a : 40mm  
b : 6.5mm  
c : 12mm

14

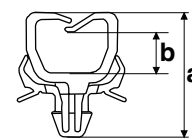

a : 12.8mm  
b : 4.2mm

15

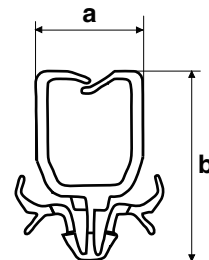

a : 9.6mm  
b : 16.8mm

16

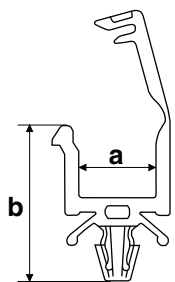

a : 11mm  
b : 21.9mm

17

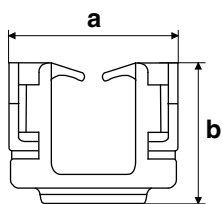

a : 11mm  
b : 9mm

18

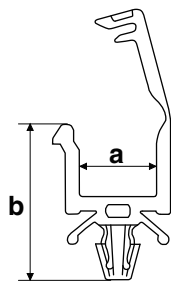

a : 16.5mm  
b : 28mm

19

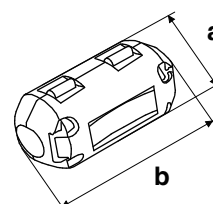

a : 17mm  
b : 30mm

20

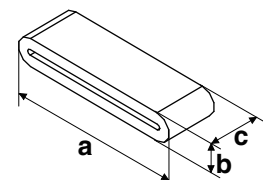

a : 40mm  
b : 6.5mm  
c : 12mm

34 付属品 (Accessories)

NO.	PARTS CODE	Inter-change	PRICE Ex.	RANK Ja.	NEW MARK	PART RANK	DESCRIPTION	Reason for change	Effective time
1	CDSKA0348QS31		AK	DX	N	D	CD-ROM(Driver)(Refer to Matrix)	CD-ROM	
	CDSKA0349QS31		AK	DX	N	D	CD-ROM(Driver)(Refer to Matrix)	CD-ROM	
	CDSKA0349QS32	3	AK	DX	N	D	CD-ROM(Driver)(Refer to Matrix)	CD-ROM	Improve performance 14/DEC RC
	CDSKA0353QS31		AK	DX	N	D	CD-ROM(Driver)(Refer to Matrix)	CD-ROM	
	CDSKA0369QS31		AS	EQ	N	D	CD-ROM(Driver)(Refer to Matrix)	CD-ROM	
	CDSKA0370QS31		AS	EQ	N	D	CD-ROM(Driver)(Refer to Matrix)	CD-ROM	
	CDSKA0371QS31		AK	EB	N	D	CD-ROM(Driver)(Refer to Matrix)	CD-ROM	
2	CDSKA0372QS31		AK	DX	N	D	CD-ROM(Driver)(Refer to Matrix)	CD-ROM	
	UDiSJ0046QSZZ		AK	DX	N	D	Operation manual(CD-ROM)(Refer to Matrix)	取扱説明書	
	UDiSR0045QSZ1		AK	DX	N	D	Operation manual(CD-ROM)(Refer to Matrix)	取扱説明書	
	UDiSZ0041QSZ2		AK	DX	N	D	Operation manual(CD-ROM)(Refer to Matrix)	取扱説明書	
3	UDiSZ0044QSZ1		AK	DX	N	D	Operation manual(CD-ROM)(Refer to Matrix)	取扱説明書	
	CDSKA0350QS31		AK	DX	N	D	CD-ROM(Driver)(Refer to Matrix) [AR-NB7]	CD-ROM	
	CDSKA0354QS31		AK	EB	N	D	CD-ROM(Driver)(Refer to Matrix) [AR-NB7]	CD-ROM	
4	CDSKA0373QS31		AK	EB	N	D	CD-ROM(Driver)(Refer to Matrix) [AR-NB7]	CD-ROM	
	CDSKA0050FC45		AK	EB		D	CD-ROM(NSX1)(Refer to Matrix) [AR-NB7]	CD-ROM	
	CDSKA0084FC42		AH	DX		D	CD-ROM(NSX1)(Refer to Matrix) [AR-NB7]	CD-ROM	
5	CDSKA0300QS32		AH	DX	N	D	CD-ROM(NSX1)(Refer to Matrix) [AR-NB7]	CD-ROM	
	TGANE0162FCZZ		AE	DS		D	Warranty [Australia]	保証書	

Matrix

No.1	CD-ROM(CD-ROM)																		
PARTS CODE	Americas			Europe			Asia			Japan(日本)									
	Americas	Europe	Asia	Americas	Europe	Asia	Americas	Europe	Asia	Japan(日本)									
CDSKA0348QS31	AR-6031N	AR-6031NR	AR-6131N	AR-6026N	AR-6023N	AR-6023NR	AR-6020N	AR-6020NR	AR-6120N	AR-6023D	AR-6020D	AR-6023	AR-6020	AR-X201	AR-X201D	AR-X231N	AR-X311N	AR-G200	
CDSKA0349QS31																			
CDSKA0349QS32																			
CDSKA0353QS31																			
CDSKA0369QS31																			
CDSKA0370QS31																			
CDSKA0371QS31																			
CDSKA0372QS31																			

No.2	取扱説明書 (Operation manual)						
PARTS CODE	Americas			Europe		Japan(日本)	
	Americas1	Europe1	Europe2	Europe3	Japan(日本)		
UDiSJ0046QSZZ	Australia	Europe1	Europe2	Europe3	Japan(日本)		
UDiSR0045QSZ1	Asia1				1st Lot		
UDiSZ0041QSZ2	Asia2				1st Lot		
UDiSZ0044QSZ1	Asia3	1st Lot			1st Lot		
	Asia4				1st Lot		
	Asia6				1st Lot		
	Brazil				1st Lot		
	SouthAfrica				1st Lot		
	Namibia				1st Lot		

No.3	CD-ROM(CD-ROM)		
PARTS CODE	Americas		Japan(日本)
	Americas	Europe	Japan(日本)
CDSKA0350QS31	Australia		
CDSKA0354QS31	Asia		
CDSKA0373QS31	Brazil		
	SouthAfrica		
	Namibia		
		Taiwan	
			1st Lot
			1st Lot

34 付属品 (Accessories)

No.4		CD-ROM(CD-ROM)		
PARTS CODE	Americas Europe1 Europe2 Australia Asia Brazil SouthAfrica Namibia	Taiwan	Japan(日本)	
CDSKA0050FC45	1st Lot			
CDSKA0084FC42		1st Lot		
CDSKA0300QS32				1st Lot

# **SHARP**

**COPYRIGHT © 2015 BY SHARP CORPORATION**

All rights reserved.

Published in Japan.

No part of this publication may be reproduced,  
stored in a retrieval system, or transmitted.

In any form or by any means,  
electronic, mechanical, photocopying, recording, or otherwise,  
without prior written permission of the publisher.

**SHARP CORPORATION**  
**Business Solutions CS Promotion Center**

First edition : September 2014

Last edition : May 2015