

TOSHIBA

SERVICE PARTS LIST

MULTIFUNCTIONAL DIGITAL SYSTEMS

e-STUDIO230/280

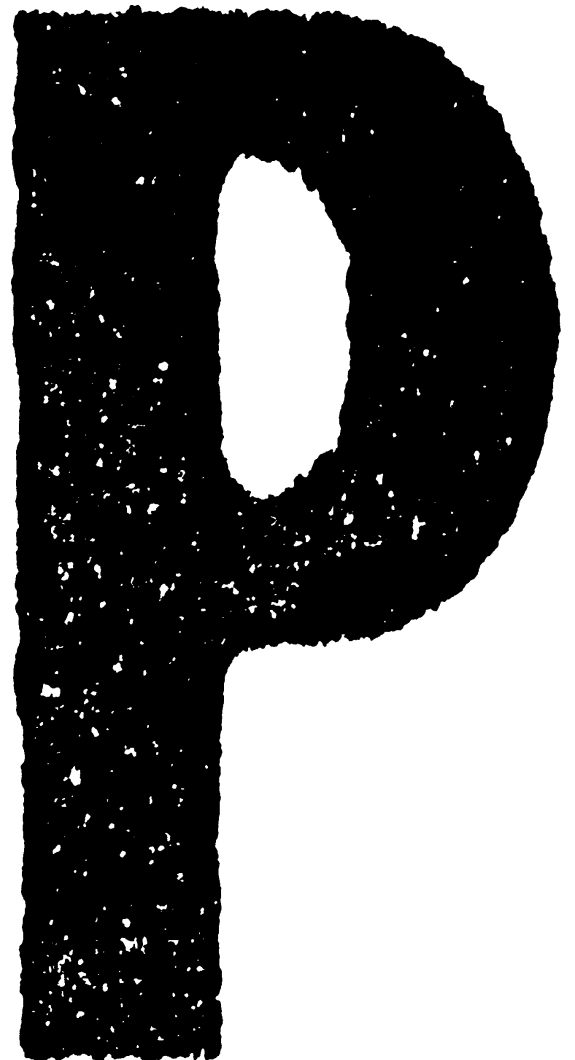

© 2004 TOSHIBA TEC CORPORATION

All rights reserved

EXPLANATION OF SERVICE-PARTS LIST

1. HOW TO READ THE PARTS LIST

- (1) Number of pieces
The number of pieces in the list denotes total pieces used per unit. But the numbers in the list for PACKING MATERIAL and ACCESSORY denote total pieces used per machine.
- (2) One pack of screws in the list includes 50 pieces.
- (3) ABBREVIATED CODES

QTY/PAC	QTY one piece PAC one pack 1/P one piece packed in polyethylene bag 1/S one piece packed in special pack 1/C one piece packed in carton box 1/PP one piece packed in paper and polyethylene bag 1/KP one piece packed in polyethylene bag with cardboard 1/D one piece packed in polyethylene-cushion bag 1/SB one piece packed in shielding bag N/A not available
---------	---

P	P PURPOSE A ADD B DELETE C CHANGE D QTY, CHANGE E MISENTRY F OMISSION
---	---

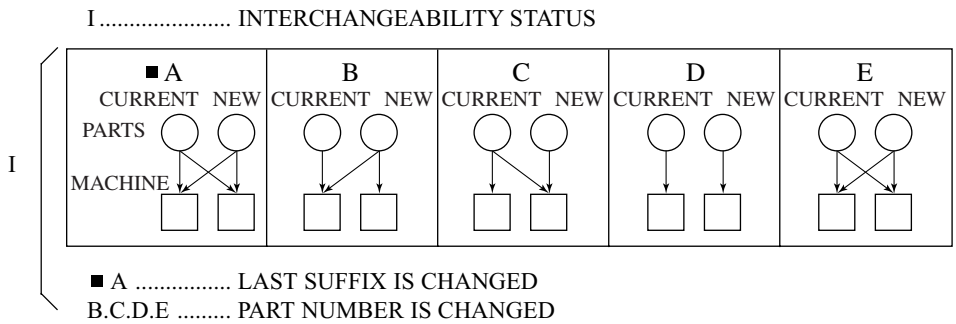

2. HOW TO PLACE ORDER FOR PARTS

- (1) The parts handled as service parts are only those with their "Q'TY/PACK" column listed with a quantity other than "N/A***" or "SUPPLY".
Those parts with "N/A***" are listed only for the purpose of showing the mechanical construction, those listed with "SUPPLY" are handled only as a sales item, and therefore both types of parts are not supplied as service parts.
- (2) Orders for any parts which form a component of a semi-assembled unit are not acceptable.
Note: All the screws and nuts used are ISO standard.

3. REGION

NAD	115V/60Hz, UL & CSA
TWD	110V/60Hz, TAIWAN
SAD	127V/60Hz, SAUDI ARABIA
ASD	220V 50/60Hz, ASIA, etc.
AUD	240V/50Hz, AUSTRALIA
MJD	230-240V 50/60Hz, EUROPE
UKD	230-240V 50/60Hz, UNITED KINGDOM

NOTICE EXPLICATIVE DE LA LISTE DES PIECES DE RECHANGE

1. COMMENT UTILISER LA LISTE DES PIECES DE RECHANGE

- (1) Nombre de pièces
Le nombre de pièces indiqué sur la liste est le nombre total de pièces utilisées pour chaque unité.
Toutefois, le nombre indiqué sur la liste EMBALLAGE ACCESSOIRES est le nombre total de pièces utilisées pour chaque machine.
- (2) Un paquet de vis indiqué sur la liste contient 50 vis.
- (3) ABREVIATIONS

Q'TY/PAC	{	QTY une pièce
		PAC un paquet
		1/P une pièce emballée dans un sac en polyéthylène
		1/S une pièce emballée dans un sac spécial
		1/C une pièce emballée dans une boîte en carton
		1/PP une pièce emballée dans un sac en papier et en polyéthylène
		1/KP une pièce emballée dans un sac en polyéthylène avec carton
		1/D une pièce emballée dans un sac rembourré en polyéthylène
1/SB une pièce emballée dans		
N/A*** non disponible		

P	{	P BUT
		A AJOUTER
		B SUPPRIMER
		C MODIFIER
		D CHANGEMENT DE QUANTITE
		E INSCRIPTION ERRONEE
		F OMISSION

I INTERCHANGEABILITE

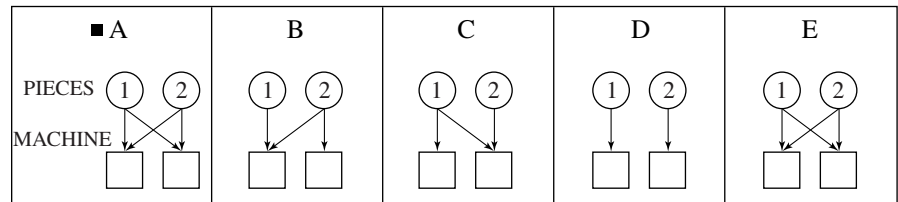

- ① ACTUELLE ② NOUVELLE
- A LE DERNIER SUFFIXE EST CHANGE
B.C.D.E LE NOMBRE DE PIECES EST CHANGE

2. COMMENT COMMANDER LES PIECES

- (1) Les pièces de rechange sont uniquement celles qui sont mentionnées dans la colonne "Q'TY/PACK" avec une quantité autre que "N/A***" ou "SUPPLY".
Les pièces dans la colonne "N/A***" sont mentionnées uniquement dans le but d'indiquer la construction mécanique. Les pièces dans la colonne "SUPPLY" sont destinées uniquement à la vente. Par conséquent, ces deux types de pièces ne sont pas fournies en tant que pièces de rechange.
- (2) Les commandes de toute pièce formant un élément ou une unité semi-assemblée ne seront pas acceptées.
Nota: Toutes les vis et tours le écrous seront conformes au code ISO.

3. PAYS

NAD	115V/60Hz, UL & CSA
TWD	110V/60Hz, TAIWAN
SAD	127V/60Hz, ARABIE SAOUDITE
ASD	220V
	50/60Hz, ASIE, etc.
AUD	240V/50Hz, AUSTRALIE
MJD	230-240V
	50/60Hz, EUROPE
UKD	230-240V
	50/60Hz, ROYAUME-UNI

ERKLÄRUNG DES ERSATZTEIL-KATALOGES

1. WIE LIEST MAN DIE TEILELISTE?

- (1) Die Teileanzahl
Die Anzahl der Teile in der Liste, drücken die gesamten Teile pro Verpackungseinheit aus. Aber die Zahl in der Liste "Packing" (Verpackung) und "Accessory" (Zubehör) beschreibt die gesamte Teileanzahl pro Maschine.
- (2) Eine Verpackungseinheit SCHRAUBEN enthält 50 Stück.
- (3) Abkürzungscode

QTY/PAC	QTY	Stück
	PAC	Packung
	1/P	ein Stück in einem Plastikbeutel
	1/S	ein Stück in einer Spezialverpackung
	1/C	ein Stück in einem Karton
	1/PP	ein Stück in Papier und einem Plastikbeutel
	1/KP	ein Stück in einem Plastikbeutel mit Pappdeckel
	1/D	ein Stück in einem gepolsterten Plastikbeutel
N/A	nicht lieferbar	
1/SB	ein Stück in einer Schutzhülle	

P	P	Zweck
	A	Zusätzlich
	B	Entfernen
	C	Ändern
	D	Menge geändert
	E	Fehlangabe
F	Weglassen	

I Austauschbar untereinander

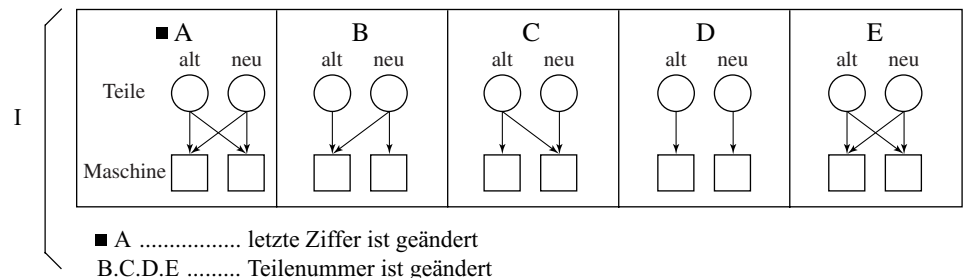

2. WIE WERDEN ERSATZTEILE BESTELLT?

- (1) Die Ersatzteile für den Service haben in der Spalte "QTY/PACK" eine Nummer.
Die Teile mit der Angabe "N/A****" sind nur aufgeführt, um die technische Konstruktion zu zeigen und sind einzeln nicht lieferbar.
Die Bezeichnung "SUPPLY" weist darauf hin, daß dieses Teil als Zubehör gehandelt wird und beim Verkauf bestellt werden muß.
- (2) Bestellungen für Einzelteile, die einer Baueinheit angehören können nicht akzeptiert werden.
Hinweis: Alle Schrauben und Muttern werden nach dem ISO-Standard hergestellt.

3. REGION

NAD	115V/60Hz, UL & CSA
TWD	110V/60Hz, TAIWAN
SAD	127V/60Hz, SAUDI-ARABIEN
ASD	220V
	50/60Hz, ASIEN, usw.
AUD	240V/50Hz, AUSTRALIEN
MJD	230-240V
	50/60Hz, EUROPA
UKD	230-240V
	50/60Hz, GROSSBRITANNIEN

SPIEGAZIONE DELLA LISTA DEI PEZZI DI RICAMBIO

1. COME LEGGERE LA LISTA DEI PEZZI DI RICAMBIO

- (1) Numero dei pezzi
Il numero dei pezzi indica il totale dei pezzi per elemento. I numeri nella lista del materiale d'imballaggio e accessori indicano il totale dei pezzi per macchina.
- (2) Nella lista, un pacco di viti contiene 50 viti.
- (3) ABBREVIAZIONI

QTY/PAC	QTY un pezzo PAC un pacco 1/P un pezzo imballato in sacco di polietilene 1/S un pezzo imballato in pacco speciale 1/C un pezzo imballato in scatola di cartone 1/PP un pezzo imballato in sacco di polietilene e carta 1/KP un pezzo imballato in sacco di polietilene con cartone 1/D un pezzo imballato in sacco morbido di polietilene 1/SB un pezzo imballato in sacco di protezione N/A non disponibile
---------	---

P	P scopo A aggiunta B annullamento C modifica D modifica QTY E ingresso errato F omissione
---	---

I stato di intercambiabilità

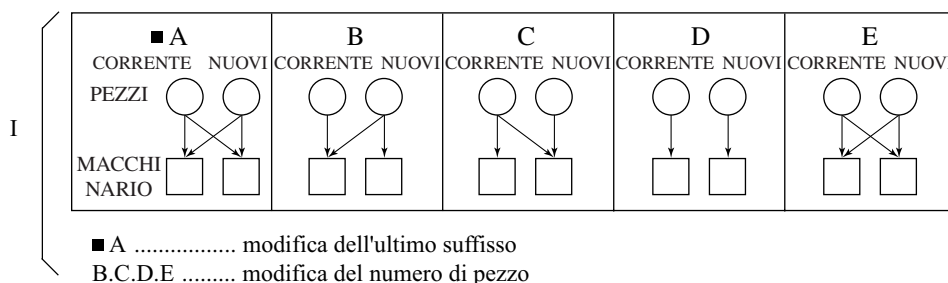

2. ORDINAZIONE DEI PEZZI

- (1) I pezzi usati come pezzi di ricambio sono elencati nella colonna "QTY/PACK" con una quantità differente da "N/A***" o "SUPPLY".
I pezzi con "N/A***" sono elencati solamente per mostrare la costruzione meccanica e quelli con "SUPPLY" sono elencati solamente come articoli di vendita: ciò significa che questi due tipi di pezzi non sono forniti come pezzi di ricambio.
- (2) L'ordinazione dei pezzi non viene accettata quando questi pezzi formano un componente di un messo elemento.
Nota: Tuttle le viti e i dadi sono standard ISO.

3. NAZIONE

NAD	115V/60Hz, UL & CSA
TWD	110V/60Hz, TAIWAN
SAD	127V/60Hz, ARABIA SAUDITA
ASD	220V 50/60Hz, ASIA, ecc.
AUD	240V/50Hz, AUSTRALIA
MJD	230-240V 50/60Hz, EUROPA
UKD	230-240V 50/60Hz, GRAN BRETAGNA

EXPLICACION DE LA LISTA DE PIEZAS DE SERVICIO

1. Cómo se lee la lista de piezas

- (1) El número de piezas
El número de piezas en la lista especifica las piezas totales usada pou unidad, mientras que el número en la lista para MATERIAL DE EMBALAJE y ACCESORIOS especifica las piezas totales usadas por máquina.
- (2) En el paquete de tornillos se incluyen 50 unidades.
- (3) Códigos abreviados

QTY/PAC	{	QTY	una pieza
		PAC	una paquete
		1/P	una pieza empaquetada en la bolsa de politileno
		1/S	una pieza empaquetada en paquete especial
		1/C	una pieza empaquetada en caja de cartón
		1/PP	una pieza empaquetada en papel y bolsa de politileno
		1/KP	una pieza empaquetada en bolsa de politileno con cartón
		1/D	una pieza empaquetada en bolsa almohadillada de politileno
1/SB	una pieza empaquetada en una		
N/A	bolsa protegida		

P PROPOSITO

P	{	A AÑADIR
		B BORRAR
		C CAMBIO
		D CANTIDAD, CAMBIO
		E ENTRADA ERRONEA
		F OMISION

I SITUACION DE INTERCAMBIABILIDAD

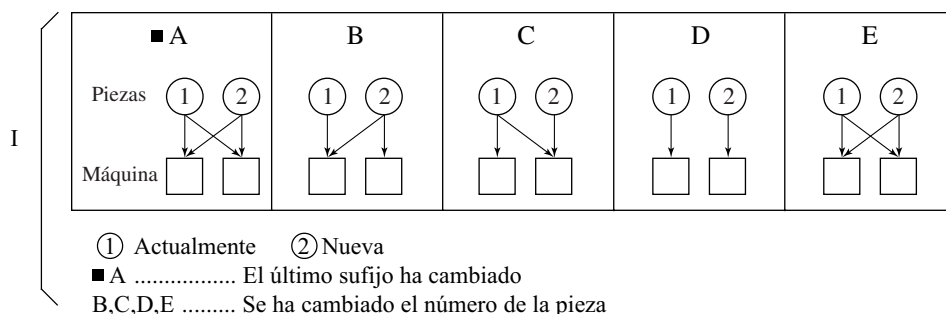

2. Cómo realizar un pedido de piezas

- (1) Las piezas consideradas como piezas de servicio son sólo aquellas designadas con Q'TY/PACK y no las designadas con N/A ... o SUPPLY.
Aquellas piezas con N/A ... se ponen en lista sólo con el propósito de mostrar la construcción mecánlca. Aquéllas piezas designadas bajo SUPPLY se consideran sólo como un artículo para ventas y por lo tanto ambos tipos de piezas no se consideran como piezas de servicio.
- (2) Los pedidos para cualquier pieza que forme un componente de la unidad semiensamblada no será aceptados.
NOTA: todos los tornillos y tuercas son del estandar ISO.

3. PAISES

NAD	115V/60Hz, UL & CSA
TWD	110V/60Hz, TAIWAN
SAD	127V/60Hz, SAUDI ARABIA
ASD	220V
	50/60Hz, ASIA, etc.
AUD	240V/50Hz, AUSTRALIA
MJD	230-240V
	50/60Hz, EUROPA
UKD	230-240V
	50/60Hz, GRAN BRETAÑA

CONTENTS

COVER-1-ASM	1	PWA-LGC-1	51
COVER-2-ASM	2	PWA-LGC-2	52
CONTROL-PANEL-ASM	3	PWA-SYS-1	53
BASE-FRAME-ASM	4	PWA-SYS-2	54
FRONT-FRAME-ASM	5	PWA-SYS-3	55
REAR-FRAME-1-ASM	6	PWA-SYS-4	56
REAR-FRAME-2-ASM	7	PWA-SYS-5	57
CASE-SYS-ASM	8	PWA-SLG-1	58
CASE-LGC-ASM	9	PWA-SLG-2	59
LASER-OPTICAL-UNIT-ASM	10		
OPTICAL-FRAME-ASM	11	JIGS & GREASE	101
COVER-GUIDE-ASM	12	DOWNLOAD JIGS	102
MAIN-DRIVE-ASM	13	SUPPLIES	103
OPTICAL-DRIVE-ASM	14	REPLACE UNIT	104
FEEDER-1-ASM	15	PM-KIT	105
FEEDER-2-ASM	16		
FEEDER-3-ASM	17		
BYPASS-ASM	18		
BYPASS-FEEDER-1-ASM	19		
BYPASS-FEEDER-2-ASM	20		
ALIGNING-ASM	21		
PLATEN-ASM	22		
CRG-1-ASM	23		
CRG-2-ASM	24		
MAIN-CHARGER-ASM	25		
TRANSPORT-CHARGER-ASM	26		
CLEANER-ASM	27		
DEVELOPER-ASM	28		
RECYCLE-ASM	29		
FUSER-ASM	30		
EXIT-ASM	31		
ADU-ASM	32		
DRAWER-ASM	33		

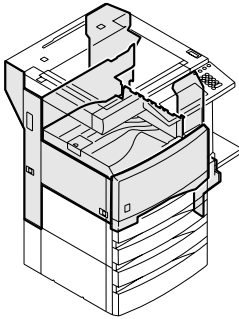
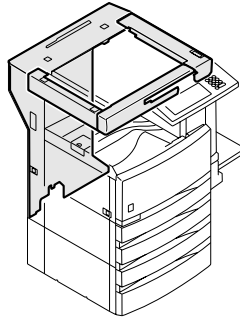
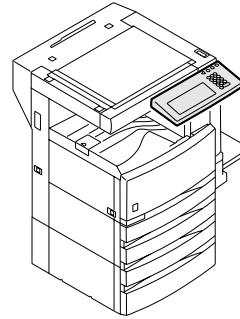
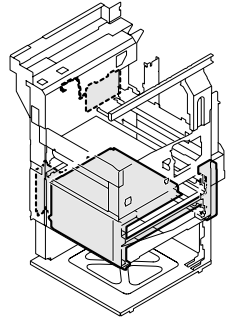
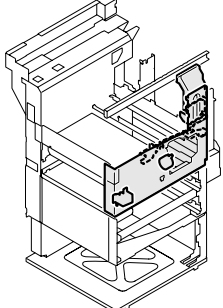
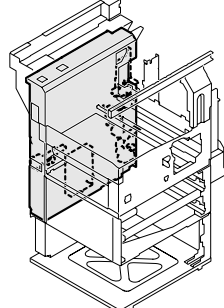
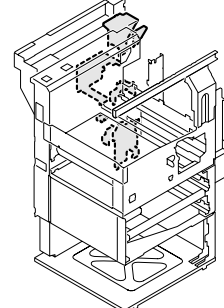
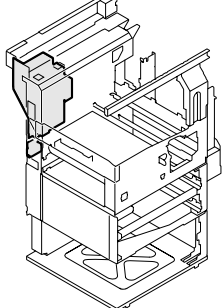
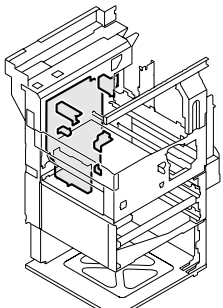
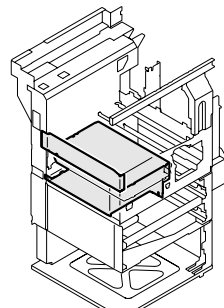
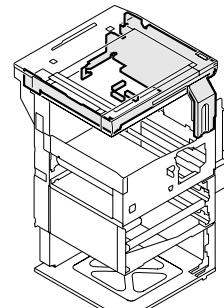
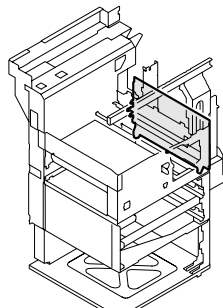
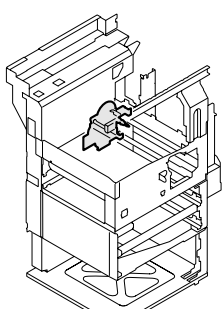
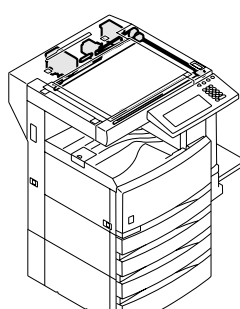
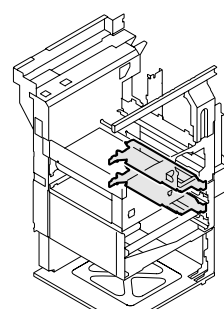
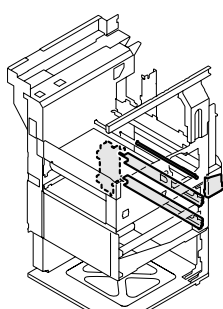
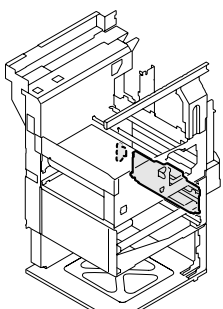
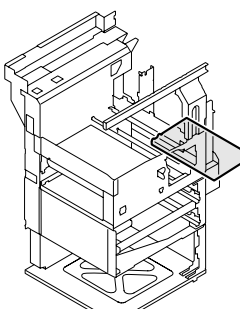
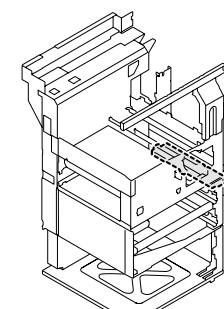
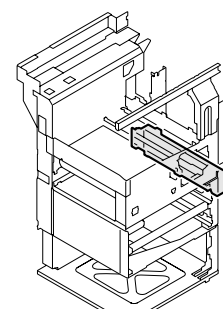
<p>1. COVER-1-ASM</p> 	<p>2. COVER-2-ASM</p> 	<p>3. CONTROL-PANEL-ASM</p> 	<p>4. BASE-FRAME-ASM</p> 
<p>5. FRONT-FRAME-ASM</p> 	<p>6. REAR-FRAME-1-ASM</p> 	<p>7. REAR-FRAME-2-ASM</p> 	<p>8. CASE-SYS-ASM</p> 
<p>9. CASE-LGC-ASM</p> 	<p>10. LASER-OPTICAL-UNIT-ASM</p> 	<p>11. OPTICAL-FRAME-ASM</p> 	<p>12. COVER-GUIDE-ASM</p> 
<p>13. MAIN-DRIVE-ASM</p> 	<p>14. OPTICAL-DRIVE-ASM</p> 	<p>15. FEEDER-1-ASM</p> 	<p>16. FEEDER-2-ASM</p> 
<p>17. FEEDER-3-ASM</p> 	<p>18. BYPASS-ASM</p> 	<p>19. BYPASS-FEEDER-1-ASM</p> 	<p>20. BYPASS-FEEDER-2-ASM</p> 

21. ALIGNING-ASM

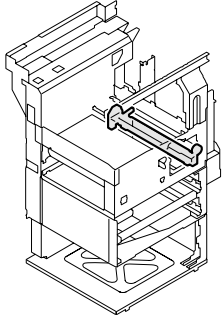

22. PLATEN-ASM

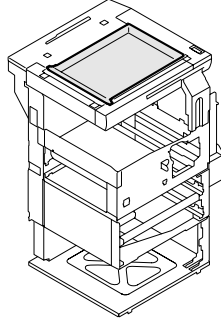

23. CRG-1-ASM

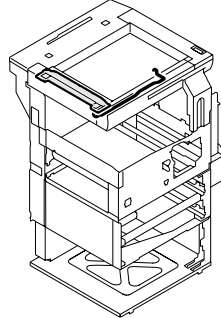

24. CRG-2-ASM

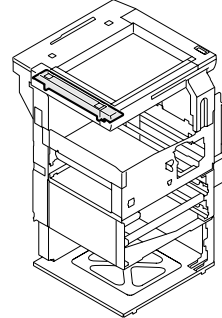

25. MAIN-CHARGER-ASM

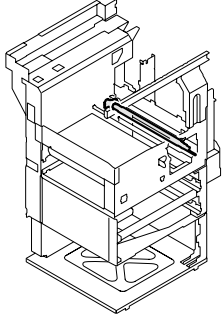

26. TRANSPORT-CHARGER-ASM

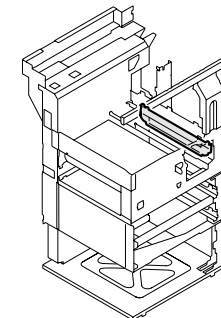

27. CLEANER-ASM

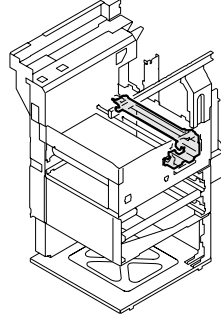

28. DEVELOPER-ASM

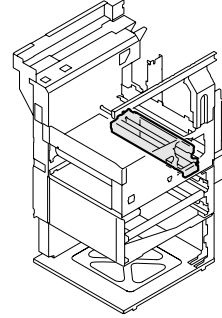

29. RECYCLE-ASM

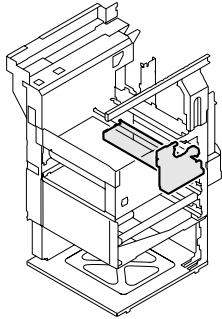

30. FUSER-ASM

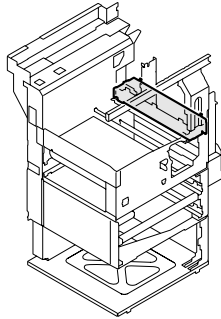

31. EXIT-ASM

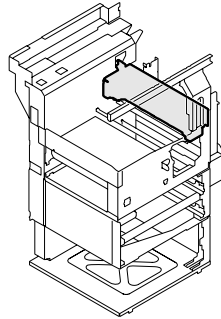

32. ADU-ASM

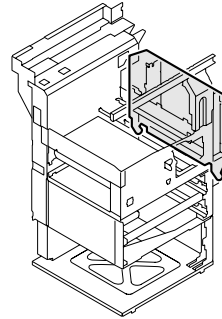

33. DRAWER-ASM

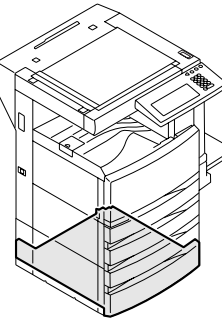

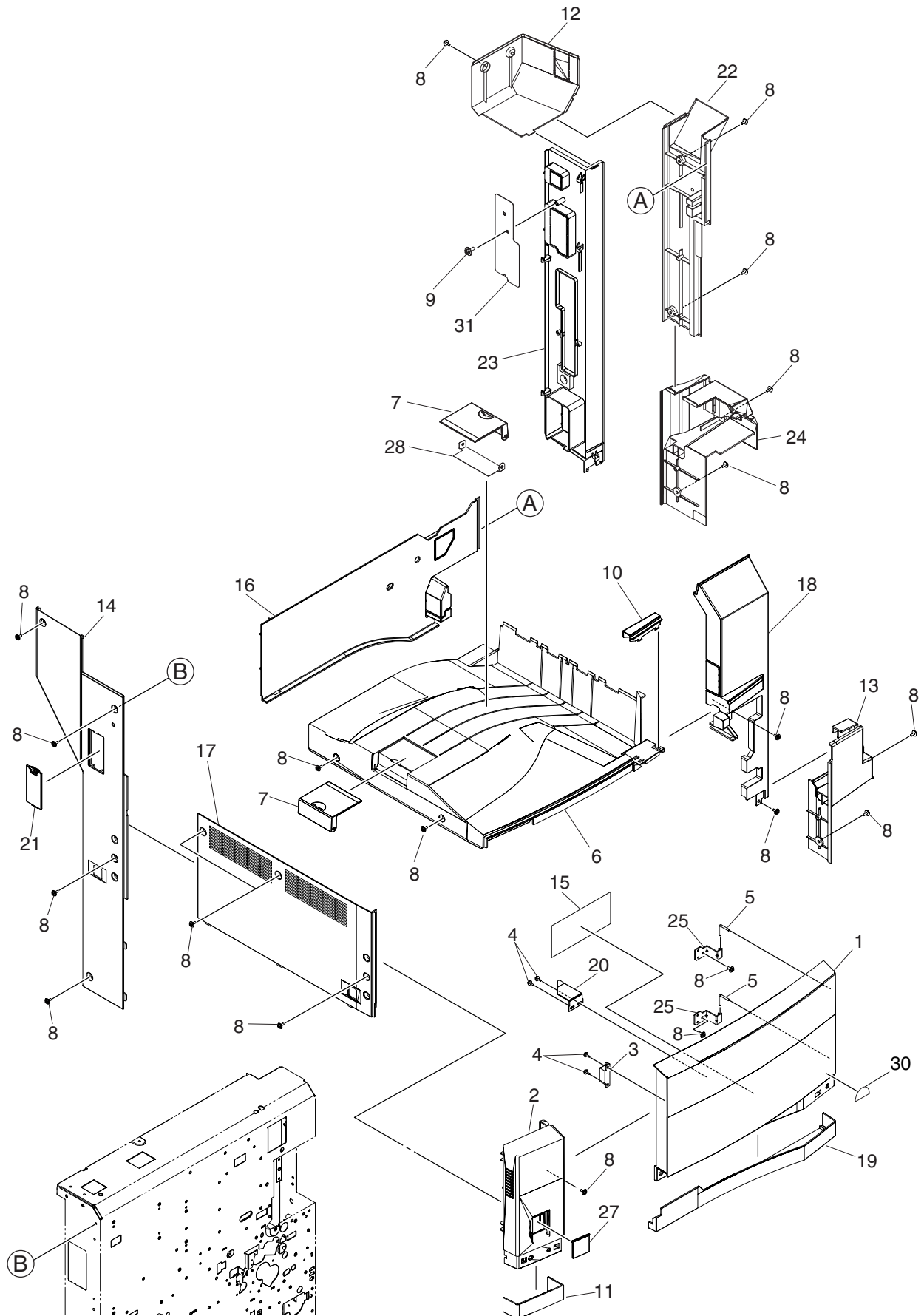

ITEM NO.	PARTS NO.	PARTS NAME	Q'TY / PAGE	Q'TY / PACK	P I R	B S I NO.	T O	T	F R O M	S E R I A L NO.	R E M A R K S	C
1A	6LA80724000	ASYS-COV-FRT-UPR-23		1/1/PP							e-STUDIO230	
1B	6LA80724100	ASYS-COV-FRT-UPR-28		1/1/PP							e-STUDIO280	
2	6LA80745000	ASYS-COV-FRT-STY-UPR		1/1/PP								
3	44200424000	MG-CATCH-44		1/1/P								
4	6LA08917000	S/TPP/HEX-3*8-NI		4/10/P								
5	6LA60573000	PIN-COVER-FRT		2/1/P								
6	6LA80702000	COVER-TRAY		1/1/PP								
7	6LA60622000	COVER-STOP-PAPER		2/1/P								
8	6LA08913000	S/TPS/HEX-4*8-NI		2/1/10/P								
9	6LA08921000	S/TPP/HEX-4*8-NI		1/10/P								
10	6LA80713000	COVER-TRAY-SUB		1/1/PP								
11	6LA60618000	COVER-FRT-STY-LWR		1/1/P								
12	6LA80963000	COVER-RGT-UPR		1/1/PP								
13	6LA80982000	COVER-HINGE-FRT		1/1/PP								
14	6LA80802000	COVER-LFT-RER		1/1/PP								
15	6LA91422000	LBL-O-TONER-FRT		1/1/KP								
16	6LA80923000	COVER-TRAY-BCK		1/1/PP								
17	6LA80763000	ASY-COV-LFT		1/1/PP								
18	6LA80782000	COVER-FRAME-FRT		1/1/PP								
19	6LA60614000	COVER-FRT-LWR		1/1/PP								
20	6LA60576000	BRKT-PUSH-SW		1/1/P								
21	6LA60630000	COVER-LFT-RER-LGC		1/1/P								
22	6LA80709000	ASYS-COVER-RGT		1/1/PP								
23	6LA80708000	ASYS-COV-RGT-LFT		1/1/PP								
24	6LA80992000	COVER-HINGE-RER		1/1/PP								
25	6LA83542000	BRKT-HINGE-FRT		2/1/P								
27	6LA60531000	LID-SW		1/1/P								
28	6LA80707000	ASYS-BRKT-STOPPER		1/1/P								
30	6LA47530000	LBL-ENERGY-T-PS		1/5/KP								
31	6LA81362000	BRKT-COVER-R-T-371		1/1/P								

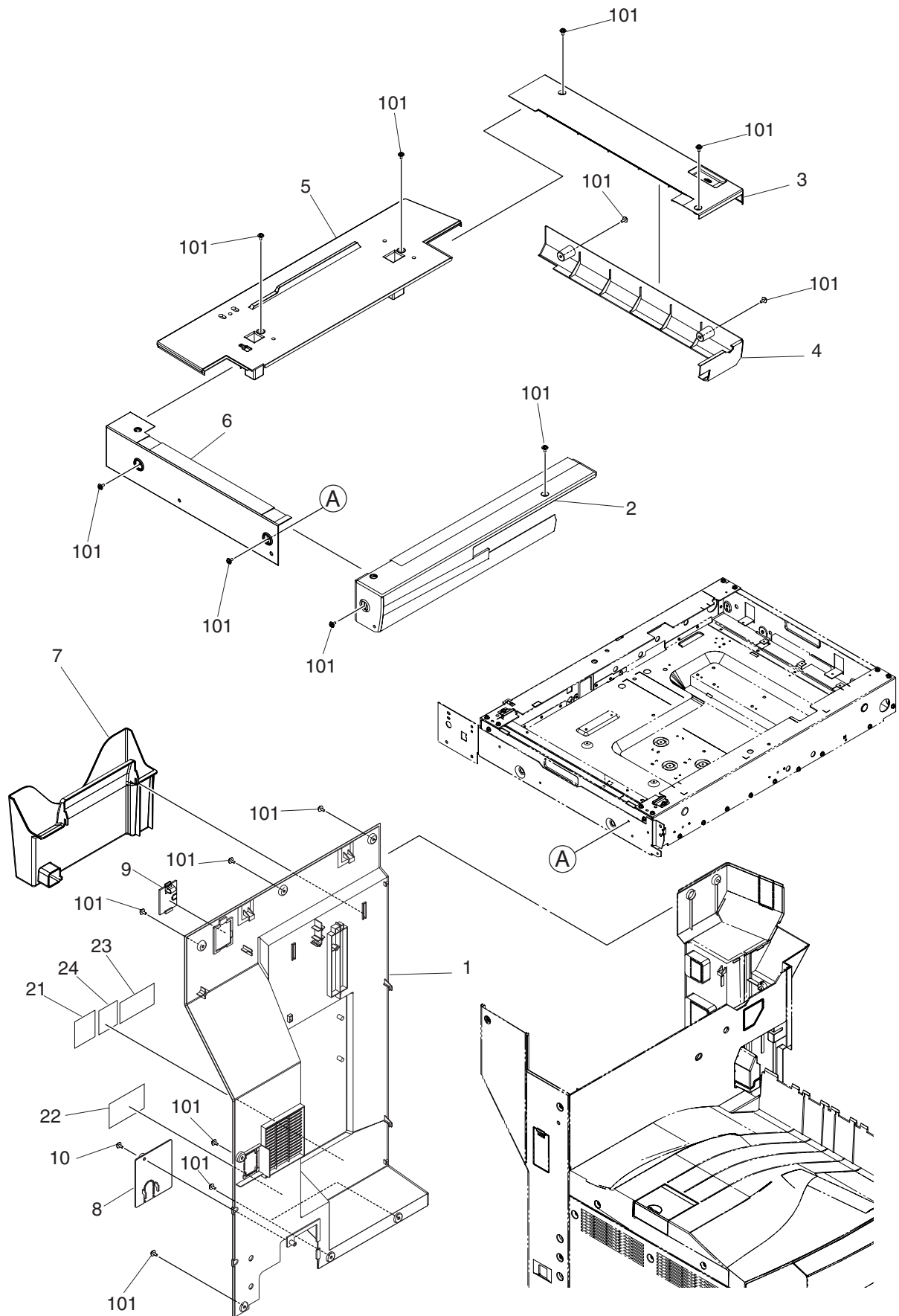

ITEM NO.	PARTS NO.	PARTS NAME	Q'TY / PAGE	Q'TY / PACK	P I R	B S I NO.	T O	T	F R O M	S E R I A L NO.	R E M A R K S	C
1	6LA80942000	COVER-RER		1/1/PP								
2	6LA80903000	COVER-TP-FRT-SCAN		1/1/PP								
3	6LA86482000	ASYS-COVER-TP-RGT-U		1/1/PP								
4	6LA80884000	COVER-TP-RGT-SCAN-L		1/1/PP								
5	6LA80863000	COVER-TP-RER-SCAN		1/1/PP								
6	6LA80843000	COVER-TP-LFT-SCAN		1/1/PP								
7	6LA60605000	POCKET-MANUAL		1/1/P								
8	6LA80943000	COVER-CNTR		1/1/PP								
9	6LA60633000	COVER-DF-CONECT		1/1/P								
10	6LA08921000	S/TPP/HEX-4*8-NI		1/10/P								
21	44204604000	LBL-SERVICE-45		1/5/P								
22	6LA47529000	LBL-LASER		1/1/KP								
23A	4400740530	LABEL-FCC		1/10/KP							NAD	
24A	4408860880	LABEL-CANADA-A		1/5/P							NAD	
25B	6LA75461000	LBL-PM		1/1/KP							MJD, TWD	
26B	4400685400	LABEL-CHINA		1/5/P							ASD, CND	
101	6LA08913000	S/TPS/HEX-4*8-NI		17/10/P								

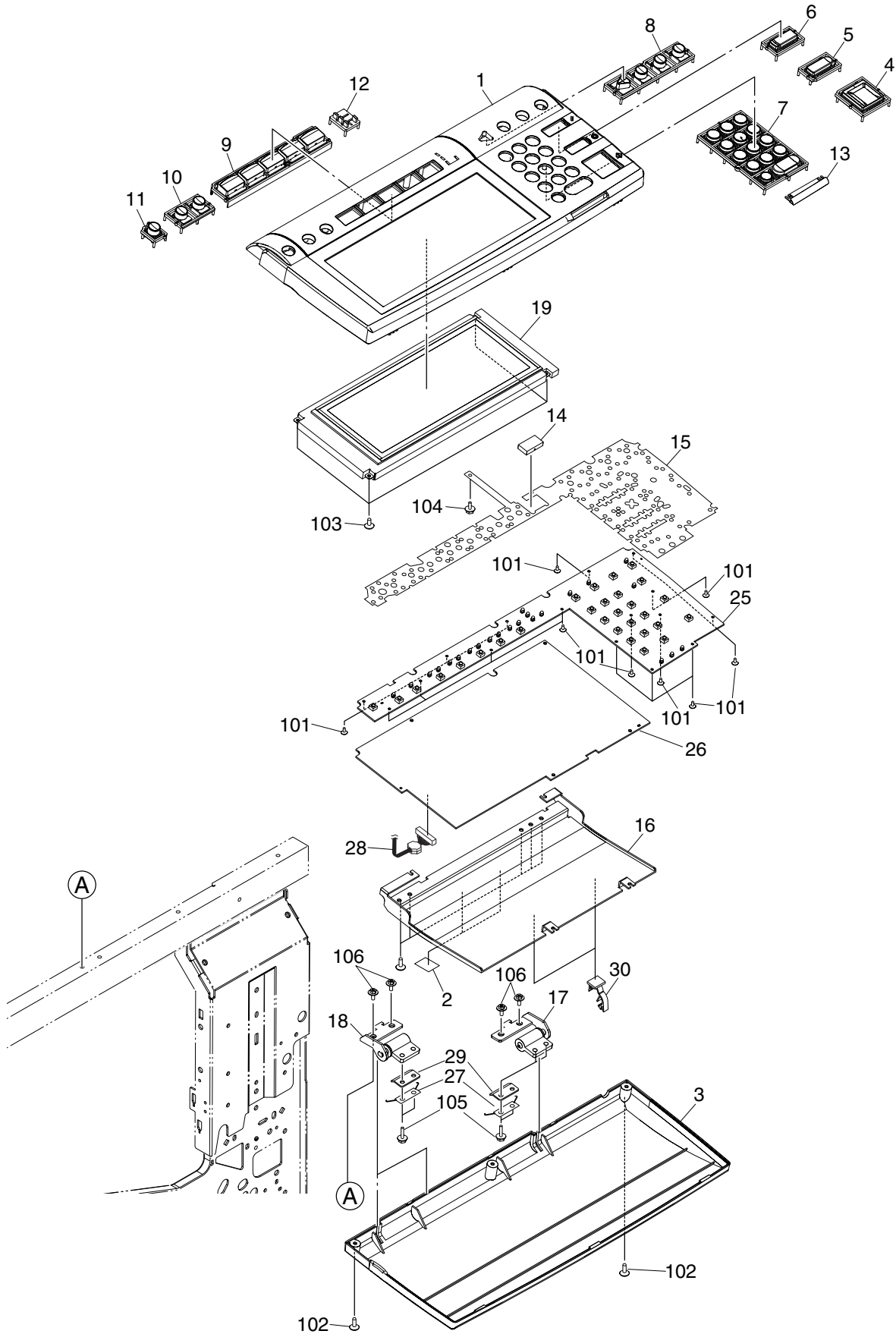

ITEM NO.	PARTS NO.	PARTS NAME	Q'TY / PAGE	Q'TY / PACK	P I R	B S I NO.	T O	T	F R O M	S E R I A L NO.	R E M A R K S	C
1	6LA37030000	ASYS-COV-CONPANE-UPR-U		11/PP								
2	6LA37038000	SHEET-BLIND		25/P								
3	6LA37004000	COVER-CONPANE-LWR		11/PP								
4	6LA37007000	KEY-START		11/D								
5	6LA37008000	KEY-STOP		11/D								
6	6LA37009000	KEY-FC		11/D								
7	6LA37010000	KEY-TEN		11/D								
8	6LA37011000	KEY-FUNCTION-A		11/D								
9	6LA37012000	KEY-FUNCTION-B		11/D								
10	6LA37013000	KEY-FUNCTION-C		11/D								
11	6LA37014000	KEY-HELP		11/D								
12	6LA37015000	LID-LED-A		11/D								
13	6LA37016000	LID-LED-B		11/D								
14	6LA37017000	PLATE-DIFFUSION		51/P								
15	6LA37018100	MYLAR-SHIELD		11/KP								
16	6LA37019000	SHIELD-CONPANE		11/D								
17	6LA37027000	ASYS-HINGE-R		21/P								
18	6LA37028000	ASYS-HINGE-L		11/P								
19	6LA37029000	ASYS-PNL-TOUCH		11/C								
25	6LA41769000	PWA-F-KEY-350		11/SB								
26	6LA41771100	PWA-F-DSP-350		11/SB								
27	6LA37037000	SPG-F-CONPANE		11/P								
28	6LA41824000	HRNS-DSP-LCD-350		11/P								
29	6LA37034000	PLATE-HINGE-OPE		31/P								
30	F0-01213000	EB-6U		25/P								
101	X0-02094000	S/TPB/BID-2X6-NI		1610/P								
102	X0-02095000	S/TPP/BRZ-3X10-NI		710/P								
103	X0-02096000	S/TPP/BRZ-3X8-NI		410/P								
104	X0-02093000	S/PAN/SWWS-M4X6-NI		110/P								
105	X0-01771000	S/PAN/SWWP-M4X12-NI		610/P								
106	6LA08913000	S/TPS/HEX-4*8-NI		610/P								

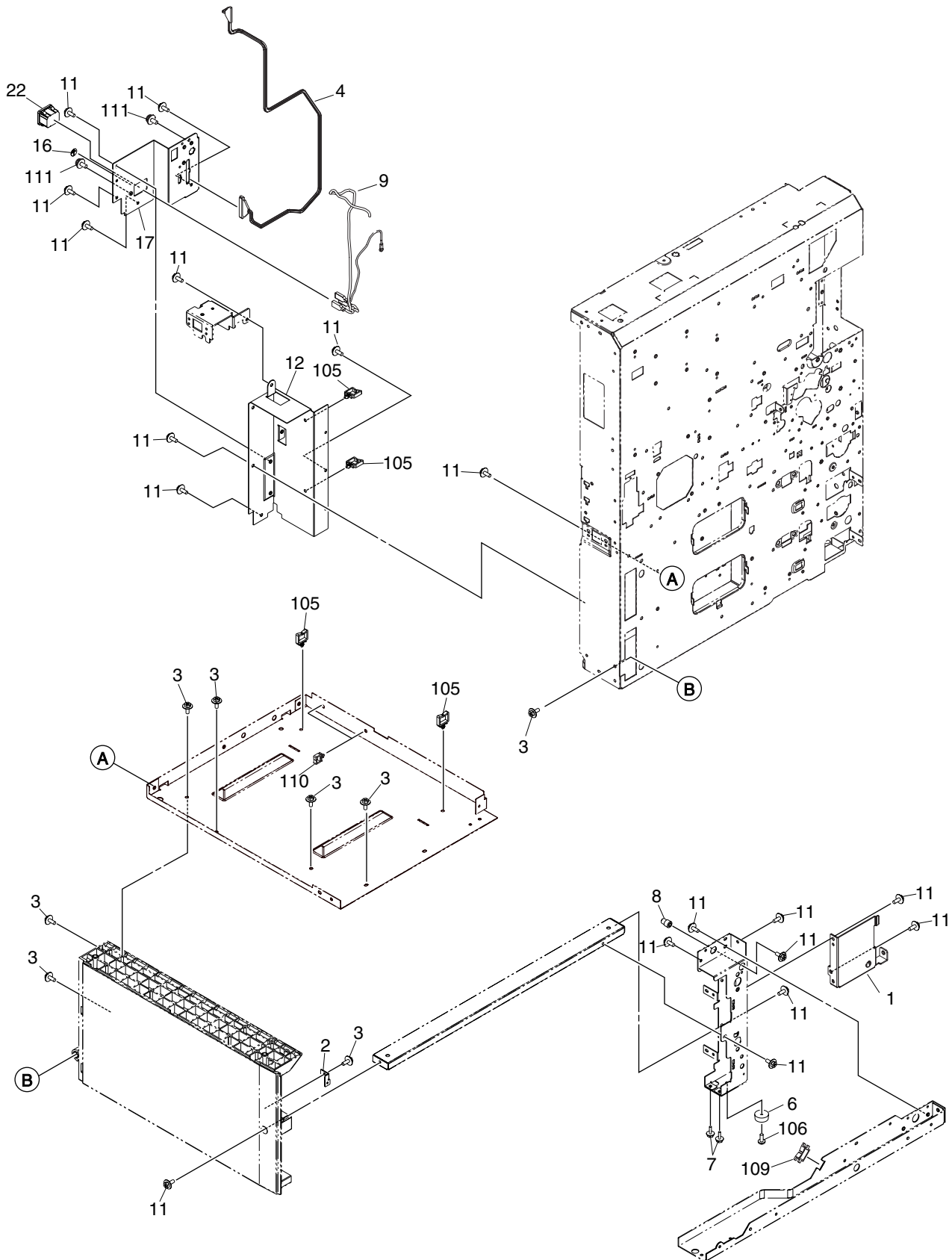

ITEM NO.	PARTS NO.	PARTS NAME	Q'TY / PAGE	Q'TY / PACK	P	I	R	BSI NO.	TO	T	FROM	SERIAL NO.	REMARKS	C
1	6LA78532000	ASYS-BRKT-HING-ADU-F		1/1/P										
2	6LA65302000	BRKT-JOINT-PFP		1/1/P										
3	6LA08921000	S/TPP/HEX-4*8-NI		7/10/P										
4	6LA89412000	HRNS-LGC-PFP-371		1/1/P										
6	41306501000	FOOT-MAIN-AT		1/1/P										
8	6LA83414000	STUD-COV-SIDE-F		1/1/P										
9	6LA89437000	HRNS-INLT-371		1/1/P										
11	6LA08913000	S/TPS/HEX-4*8-NI		23/10/P										
12	6LA81360000	COVER-CSST-BACK		1/1/PP										
16	4404610110	MARK-EARTH-VDE		1/10/P										
17	6LA81326000	BRKT-INLET-371		1/1/P										
19A	6LA55883000	CABLE-P-INLET-US		1/1/P									NAD	
19B	4400395940	CBL/P-INLET-EUR		1/1/P									MJD,ASD,TW	
													D	
19C	4400494940	CBL/P-INLET-AU		1/1/P									AUD	
22	E0-06067000	NC-179-F6.35		1/1/P										
105	F0-01298000	WS-2N-V0		4/5/P										
106	X0-02074000	S/TPS/BID-4X8-ZU3		1/10/P										
109	F0-00041000	EDS-2		1/10/P										
110	F0-00024000	LWS-1U		2/5/P										
111	X0-00169000	S/PAN/SWWP-M4X8-BSNI		2/10/P										

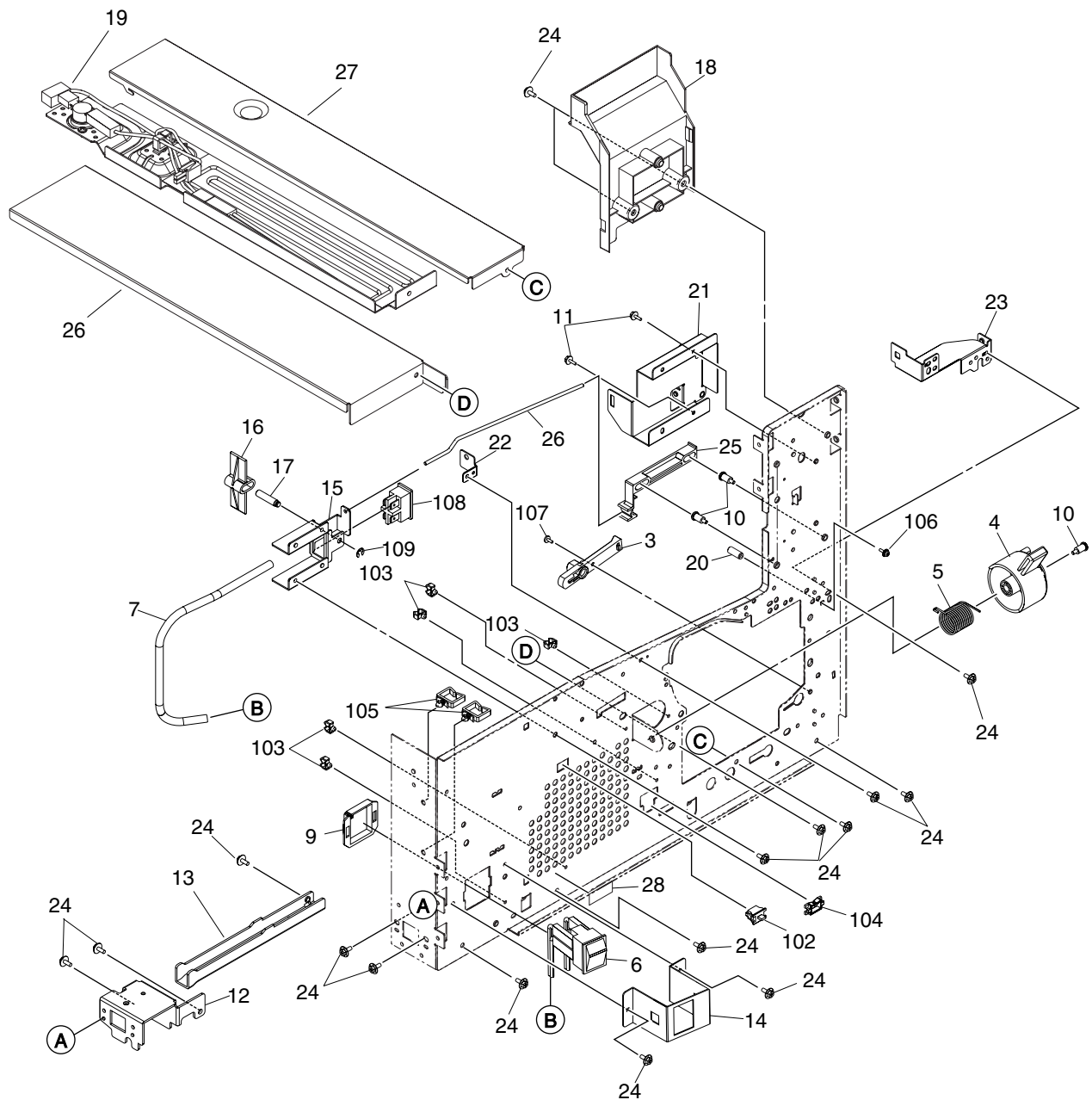

ITEM NO.	PARTS NO.	PARTS NAME	Q'TY / PAGE	Q'TY / PACK	P I R	B S I NO.	T O	T	F R O M	S E R I A L NO.	R E M A R K S	C
3	6LA85861000	HOLDER-RGST-F		1/1/P								
4	6LA88010000	LEVER-TNR-C		1/1/P								
5	6LA88014000	SPG-LEVER-TNR-C		1/1/P								
6	44205162000	SZ-AJ8R2004ZC		1/1/D								
7	6LA89438000	HRNS-MAIN-SW-371		1/1/P								
8	6LA89460000	HRNS-RSTSW-371		1/1/P								
9	4406509170	BD/W-TWS-3027		1/1/P								
10	44200855000	STUD-DRSW-TR		3/1/P								
11	6LA08909000	S/TPS/HEX-3*8-NI		2/10/P								
12	6LA35525000	BRKT-HANDLE		1/1/P								
13	6LA35534000	HANDLE		1/1/P								
14	6LA65137000	BRKT-SW-MAIN		1/1/P								
15	6LA65301000	BRKT-DOOR-SW		1/1/P								
16	44200852000	GUIDE-SW-DOOR		1/1/P								
17	44200854000	STUD-DOOR-SW		1/5/P								
18	6LA80823000	COVER-FRAME-FRT-BCK		1/1/PP								
19B	6LA85424200	ASY-DHTR-DRUM-371-E		1/1/C							ASD,AUD,CN D	
20	6LA83415000	STUD-COV-SIDE		1/5/P								
21	6LA83522000	ASYS-EXIT-FRM-F		1/1/P								
22	6LA83543000	BRKT-DOOR-SW-SUB		1/1/P								
23	6LA83533000	BRKT-ADJ-FUS		1/1/P								
24	6LA08913000	S/TPS/HEX-4*8-NI		19/10/P								
25	6LA81500000	GUIDE-DOOR-SW-SUB		1/1/P								
26	6LA83801000	COVER-DHTR-HRNS-DRUM		1/1/P								
27	6LA83802000	COVER-DHTR-DRUM-371		1/1/P								
28	6LA91431000	LBL-CAU-LASER		1/1/KP								
102	E0-01853000	CS1A-B2CA		1/1/D							SWITCH	
103	F0-00043000	UAMS-05SN-W		5/5/P								
104	F0-00045000	EDS-1		1/10/P								
105	F0-01298000	WS-2N-V0		2/5/P								
106	X0-00077000	S/PAN/SWWP-M3X8-NI		1/10/P								
107	6LA08935000	SCR-M3X6BISR-NI		1/10/P								
108	E0-02347000	AGX226		1/1/D							SWITCH	
109	X0-00965000	RR/E-4-SS		1/10/P								

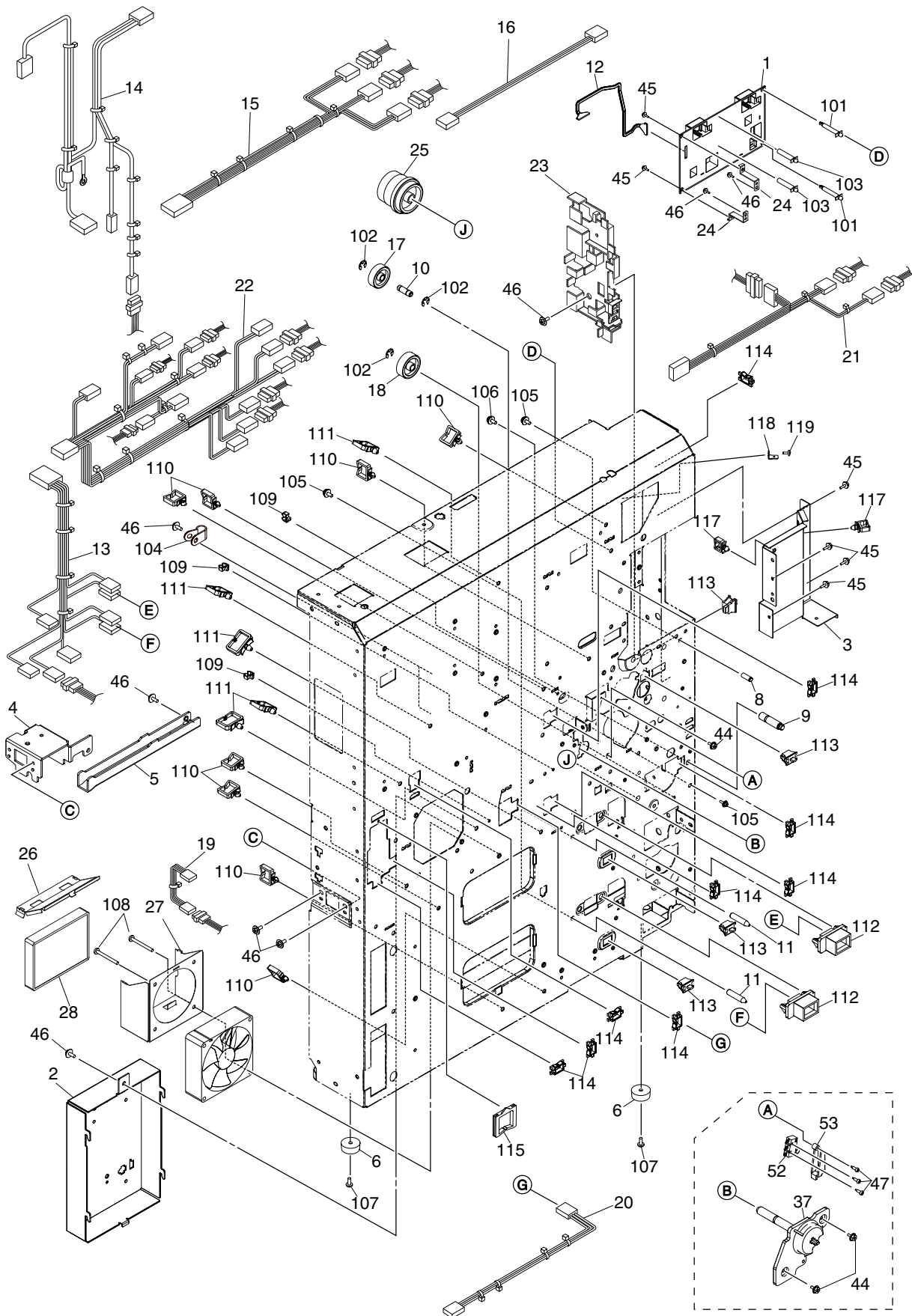

ITEM NO.	PARTS NO.	PARTS NAME	Q'TY / PAGE	Q'TY / PACK	PIR	BSI NO.	TO	T	FROM	SERIAL NO.	REMARKS	C
1	6LA89102000	PS-HVT-371		1/1/C								
2	6LA83424000	BRKT-DHTR		1/1/P								
3	6LA83527000	BRKT-FRAME-ADU		1/1/P								
4	6LA35525000	BRKT-HANDLE		1/1/P								
5	6LA35534000	HANDLE		1/1/P								
6	41306501000	FOOT-MAIN-AT		2/1/P								
7	6LA89111000	FAN-D-3110KL-05W-B60		1/1/D								
8	6LA83415000	STUD-COV-SIDE		1/5/P								
9	6LA83425000	STUD-COV-SIDE-R		1/1/P								
10	6LA83554000	STUD-DRV-24-BYP-371		1/1/P								
11	6LA83392000	STUD-FIX-FEED-UNIT		2/1/P								
12	6LA89403000	HRNS-LGC-HVPS-371		1/1/P								
13	6LA89409000	HRNS-LGC-FEDU-371		1/1/P								
14	6LA89477000	HRNS-PWR-FIN-371-W		1/1/P								
15	6LA89407000	HRNS-LGC-ADU-371		1/1/P								
16	6LA89461000	HRNS-TNR-FULL-371		1/1/P								
17	6LA79003000	GEAR-10S024-06-DRV		1/1/P								
18	6LA79004000	GEAR-10S026-06-DRV		1/1/P								
19	6LA89413000	HRNS-LGC-POL-371		1/1/P								
20	6LA89439000	HRNS-LP-ACIN-371		1/1/P								
21	6LA89405000	HRNS-LGC-EXIT-371		1/1/P								
22	6LA89406000	HRNS-LGC-MOT-371		1/1/P								
23	6LA83402000	GUIDE-HRNS-371		1/1/PP								
24	6LA81350000	BRKT-HVT-371		2/1/P								
25	6LA83048000	GG10S040-10S034		1/1/P								
26	6LA83418000	COV-DUCT-FAN-REAR		1/1/P								
27	6LA83422000	DUCT-FAN-REAR-2		1/1/P								
28	6LA88355000	FILTER-OZONE-371		1/1/C								
37	6LA82254000	ASYS-HLDR-DEV-371		1/1/P								
45	6LA08909000	S/TPS/HEX-3*8-NI		5/10/P								
46	6LA08913000	S/TPS/HEX-4*8-NI		4/10/P								
47	44204394000	SCREW20*D23		3/10/P								
52	6LA68913000	SW-DE3LAASB-TNR		1/1/C								
53	6LA03099000	COVER-SW-340		1/1/P								
101	F0-00315000	SPLSN-22U		2/5/P								
102	X0-00966000	RR/E-5-SS		3/10/P								
103	F0-00330000	SPSN-22U		2/5/P								
104	F0-00119000	EMT-4N		2/1/P								
105	X0-00077000	S/PAN/SWWP-M3X8-NI		4/10/P								
106	X0-00164000	S/PAN/SWWP-M4X8-NI		1/10/P								
107	X0-02074000	S/TPS/BID-4X8-ZU3		2/10/P								
108	X0-02114000	S/TPS/PAN-4X32-ZU3		2/10/P								
109A	F0-00043000	UAMS-05SN-W		2/5/P							NAD,MJD	
109B	F0-00043000	UAMS-05SN-W		3/5/P							ASD,AUD,CN	
											D,TWD	
110	F0-01298000	WS-2N-V0		9/5/P								
111	F0-01252000	WS-4W		5/5/P								
112	E0-01106000	55533-1211		2/5/P								
113	E0-01853000	CS1A-B2CA		4/1/D							SWITCH	
114	F0-00045000	EDS-1		8/10/P								
115	F0-00034000	EDS-2323U		1/5/P								
117	F0-00024000	LWS-1U		2/5/P								
118	E0-06031000	42117-2		1/5/P								
119	X0-00676000	S/TPS/BID-3X6-NI		1/10/P								

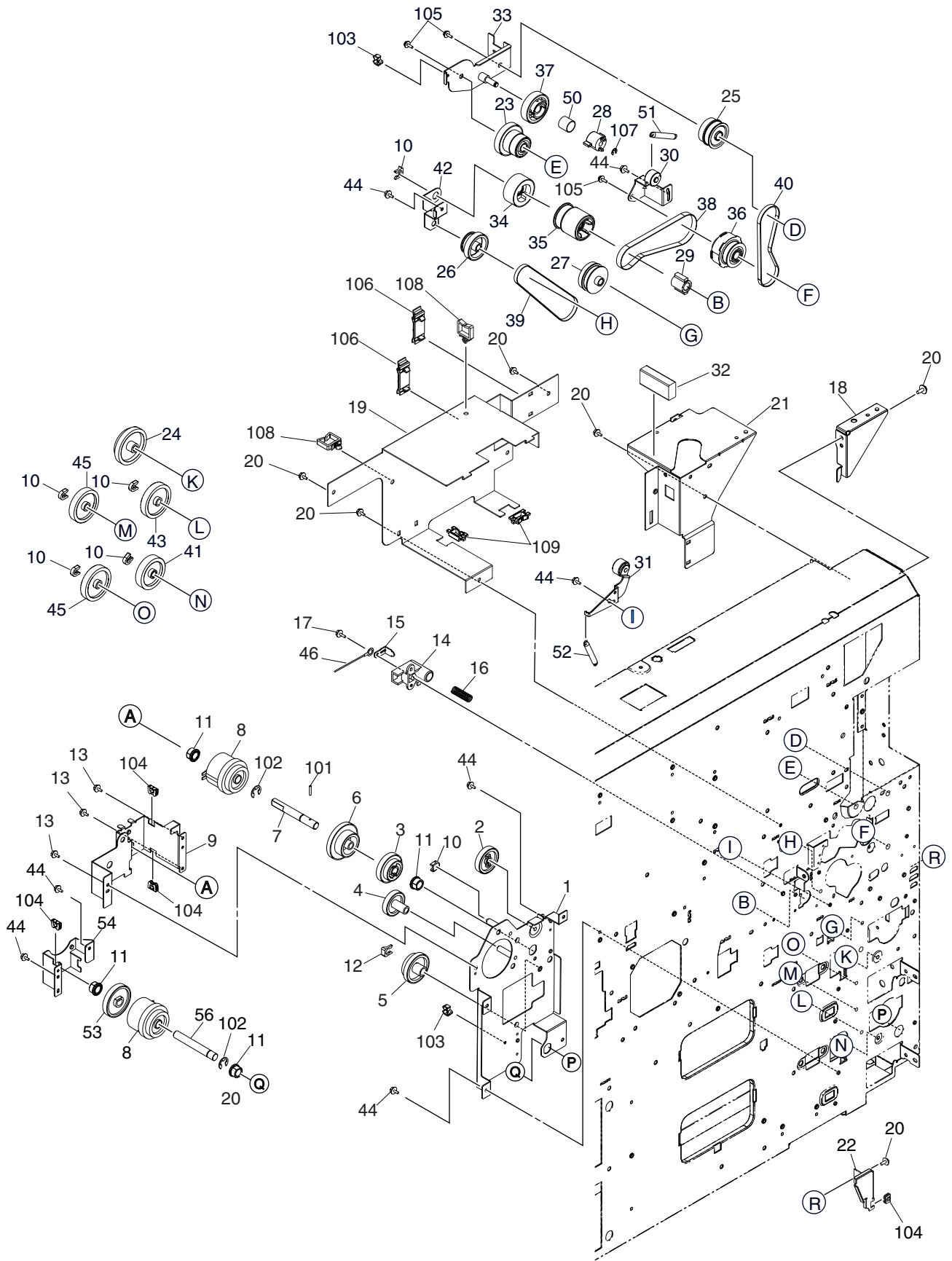

ITEM NO.	PARTS NO.	PARTS NAME	Q'TY / PAGE	Q'TY / PACK	P I R	B S I NO.	T O	T	F R O M	S E R I A L NO.	R E M A R K S	C
1	6LA83042000	ASYS-DRV-FEED-MAIN		11/P								
2	6LA83114000	GEAR-10S028-06		11/P								
3	6LA83115000	GG10S022-10S031		11/P								
4	6LA83113000	GEAR-10S026-06		11/P								
5	6LA83112000	GG10S025-10S032		11/P								
6	6LA83056000	GG10S026/10S040-371		11/P								
7	6LA83086000	SHAFT-ID-CLT-RELAY		11/P								
8	6LA82840000	CLUTCH-G28-08D-35E		21/D								
9	6LA83053000	BKT-DRV-FED-SUB		11/P								
10	4407972860	STOP-RING-6-5		55/P								
11	6LA65698000	BUSH-8X12X8F		45/P								
12	4400336190	STOP-RING-8		25/P								
13	6LA08908000	S/TPS/HEX-3*6-NI		310/P								
14	6LA82002000	TERMINAL-DEV		11/P								
15	6LA82004000	PLT-TERM-DEV		11/P								
16	6LA82006000	SPC-TERM		15/P								
17	6LA08917000	S/TPP/HEX-3*8-NI		110/P								
18	6LA83516000	BRKT-REINF-STY-TP-R1		11/P								
19	6LA81317000	BRKT-SCAN-HRNS		11/P								
20	6LA08913000	S/TPS/HEX-4*8-NI		910/P								
21	6LA81312000	BRKT-REINF-STY-TP2		11/P								
22	6LA83403000	COVER-CONNECT-371		11/P								
23	6LA82292000	GEAR-8H31-10H20-6		11/P								
24	44201681000	GG10S031/10S038		11/P								
25	6LA82290000	GEAR-10H23-PS3M27-4		11/P								
26	6LA82279000	GEAR-10H27-PS2M32-6		11/P								
27	6LA82281000	GEAR-10H27-PS2M41-6		11/P								
28	6LA82296000	CPG-DRV-CLN		11/P								
29	6LA82220000	CPG-GR-JOINT-S		11/P								
30	6LA82258000	ASYB-BLT-TENS-C/F		11/P								
31	6LA82264000	ASYB-BLT-TENS-RGT		11/P								
32	6LA86471000	GSKT-18-10-40		11/P								
33	6LA82285000	ASYS-BRKT-CLN-FUS		11/P								
34	6LA82224000	ASYS-GEAR-8M35-8-JOIN-B		11/P								
35	6LA82261000	ASYS-GEAR-JOIN-BLT		11/P								
36	6LA82267000	ASYS-GEAR-RGST		11/P								
37	6LA82294000	GEAR-10H29-6-CLN		11/P								
38	6LA82273000	BLT-SY-S2M-250-6		11/P								
39	6LA82277000	BLT-SY-S2M-266-4		11/P								
40	6LA82275000	BLT-SY-S3M-222-4		11/P								
41	44201746000	GEAR-10S033-06		11/P								
42	6LA82243000	BRKT-DRV-FEED-A		11/P								
43	44201683000	GEAR-10S034-06		11/P								
44	6LA08908000	S/TPS/HEX-3*6-NI		1010/P								
45	44201862000	GEAR-10S035-06		21/P								
47	6LA89436000	HRNS-HVT-DEV-371		11/P								
50	6LA82298000	SPG-C-13R5*1*21R7L-CN		15/P								
51	6LA82313000	SPG-E-5R5*R8*33R4-TNS		11/P								
52	6LA82202000	SPG-E-5XR5X29R92-TNS		11/P								
53	6LA83082000	GEAR-10S035-08D		11/P								
54	6LA83060000	BRKT-DRV-FED-CLT		11/P								
56	6LA83085000	SHAFT-ID-CLT-371		11/P								
101	X0-01526000	P/PRL/AH7-2X12-SS		110/P								
102	X0-00968000	RR/E-7-SS		210/P								
103	F0-00043000	UAMS-05SN-W		15/P								
104	F0-00339000	EHP-6U		35/P								
105	X0-00077000	S/PAN/SWWP-M3X8-NI		310/P								
106	F0-01047000	LFCS-30		21/P								
107	X0-00964000	RR/E-3-SS		110/P								
108	F0-01298000	WS-2N-V0		25/P								
109	F0-00045000	EDS-1		210/P								

ITEM NO.	PARTS NO.	PARTS NAME	Q'TY / PAGE	Q'TY / PACK	PIR	BSI NO.	TO	T	FROM	SERIAL NO.	REMARKS	C
1	6LA81361000	BRKT-COVER-R-R-371		11/P								
2	6LA81316000	BRKT-FAX-371		11/P								
3	6LA34629000	COV-CNCT-DWN		11/P								
4	6A000000048	GC-1180		1SUPPLY								OPT
5B	6LA42007000	PWA-F-FUS-350		11/C							ASD,AUD	
6	6LA08921000	S/TPP/HEX-4*8-NI		110/P								
7	C0-06554000	FML8L08-70-P		11/S							FRAM (IC54)	MSP
9	6LA81333000	COVER-SYS-L-371		11/P								
12	6LA81332000	COVER-SYS-U-371		11/P								
13	6LA89457000	HRNS-HDD-SIG-371		11/P								
14	6LA89458000	HRNS-HDD-POW-371		11/P								
15	44201086000	SCREW-#6-32*1/4		110/P								
16	6LA56134000	DAMPER-HDD-320		45/P								
17	44201254000	SCREW-HDD-DSS		410/P								CNT
19	6LA81315000	BRKT-SYS-RGT-371		11/P								
20	6LA88724000	ASY-PWA-SYS-371S		11/SB								
23	6LA08909000	S/TPS/HEX-3*8-NI		1210/P								
24	6LA34634000	BUSH-KG-016L-FA		15/P								
25	6LA34635000	BUSH-KG-016L-SC		15/P								
29	6LA89144000	CTRL-F-NIC-371		11/SB								
30	6LA34672000	BRKT-NIC-EARTH		21/P								
32	6LA34678000	GSKT-STG1-10CF		15/P								
33	6LA08908000	S/TPS/HEX-3*6-NI		1010/P								
34	6LA34683000	MYLAR-NIC		11/KP								
37	6LA81328000	ASYS-CASE-SYS		11/PP								
38	6LA08913000	S/TPS/HEX-4*8-NI		3110/P								
39	G0-00291000	6E040L0		11/C							HDD	
40	6LA89440000	HRNS-FUSE-371		11/P								
41B	6LA89442000	HRNS-D/H-371		11/P							ASD,AUD	
46	6LA81334000	TERM-HDD-EARTH-371		11/P								
102	F0-00280000	WLS-20-0		15/P								
104B	F0-00343000	SPLSN-8U		45/P							ASD,AUD	
106	F0-00045000	EDS-1		310/P								
109	F0-00273000	WLS-06-0		25/P								
111	F0-00047000	EDS-1717U		310/P								

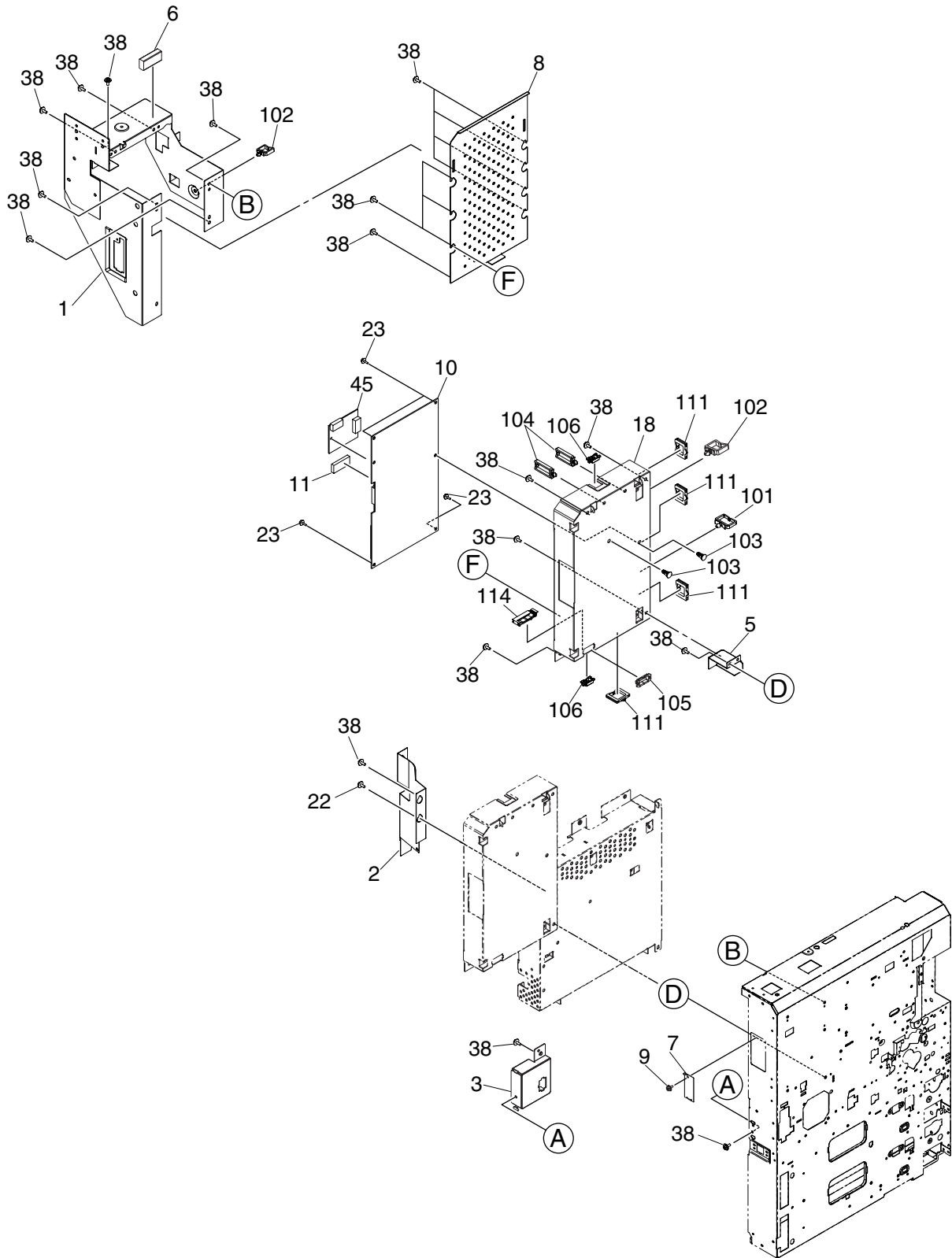

ITEM NO.	PARTS NO.	PARTS NAME	Q'TY / PAGE	Q'TY / PACK	PIR	BSI NO.	TO	T	FROM	SERIAL NO.	REMARKS	C
1	6LA83518000	ASYS-BRKT-SCAN-LFT		1/1/P								
2	6LA81370000	ASYS-BKT-COV-SYS-LGC		1/1/P								
3	6LA81319000	BRKT-CNTR-FNSR-371		1/1/P								
4	6LA81501000	SHAFT-DOOR-SW		1/1/P								
5	6LA81310000	BRKT-LGC-371		1/1/P								
6	6LA86471000	GSKT-18-10-40		1/1/P								
7	6LA34627000	LID-LGC		1/1/P								
8	6LA81324000	COVER-LGC-371		1/1/P								
9	6LA08908000	S/TPS/HEX-3*6-NI		1/10/P								
10A	6LA89809000	ASY-PWA-LGC-371S		1/1/SB							e-STUDIO230	
10B	6LA89810000	ASY-PWA-LGC-372S		1/1/SB							e-STUDIO280	
18	6LA81323000	CASE-LGC-371		1/1/P								
23	6LA08909000	S/TPS/HEX-3*8-NI		4/10/P								
38	6LA08913000	S/TPS/HEX-4*8-NI		19/10/P								
101	F0-01252000	WS-4W		1/5/P								
102	F0-01298000	WS-2N-V0		1/5/P								
103	F0-00229000	KGLS-8RT		2/5/P								
104	F0-01297000	WS-4N-V0		2/5/P								
105	F0-00199000	TSB-1909N		1/1/P								
106	F0-00045000	EDS-1		2/10/P								
111	F0-00047000	EDS-1717U		4/10/P								
114	F0-01047000	LFCS-30		1/1/P								

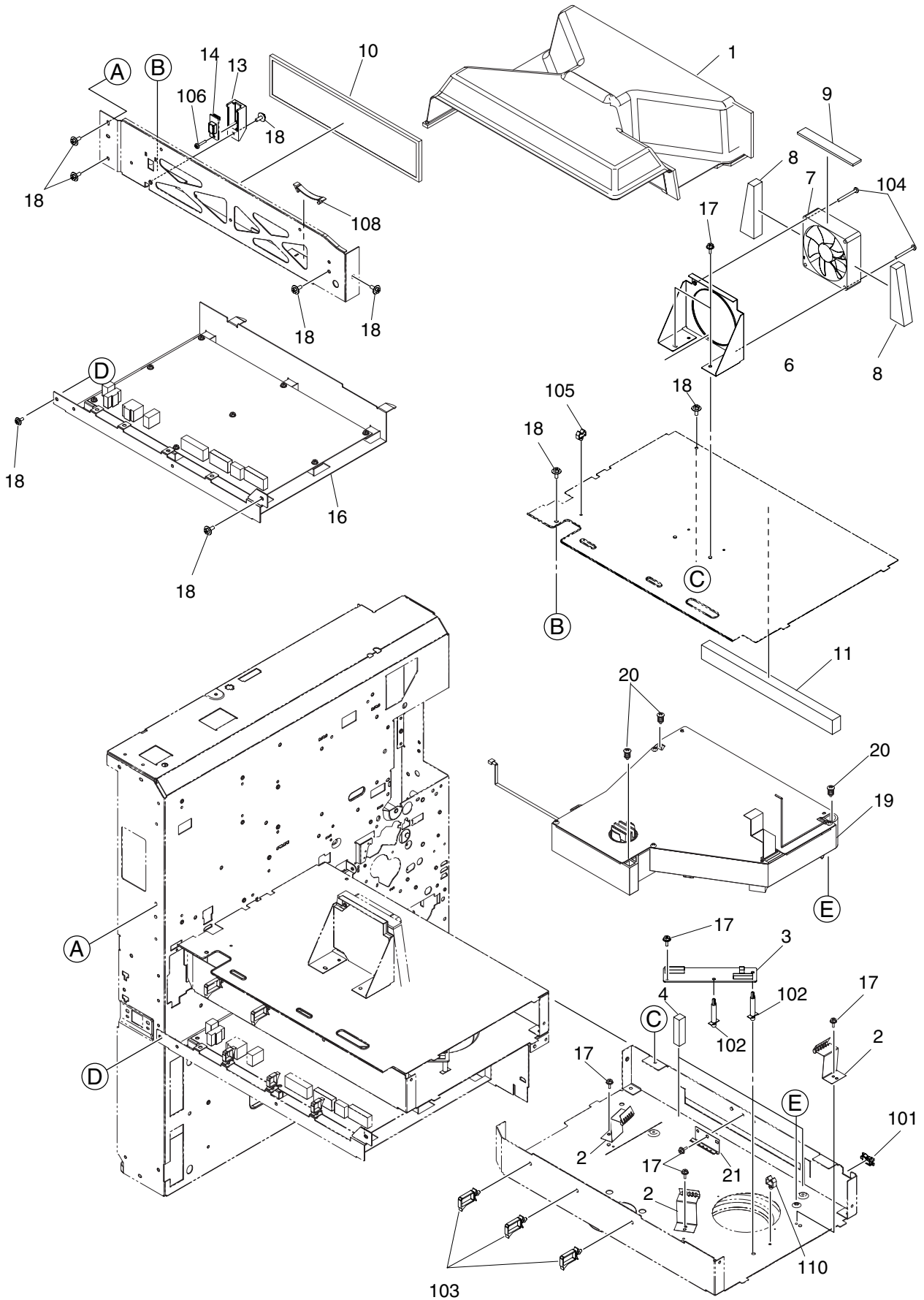

ITEM NO.	PARTS NO.	PARTS NAME	Q'TY / PAGE	Q'TY / PACK	P	I	R	B S I NO.	T O	T	F R O M	S E R I A L NO.	R E M A R K S	C
1	6LA83594000	ASYS-DUCT-FAN-TNR		1/1/PP										
2	6LA83405000	SPL-FG-LSU-A		3/1/P										
3	6LA69849000	PWA-F-IRL-360		1/1/SB										
4	6LA84872000	SEAL-GLASS-LSU-S		2/1/D										
6	6LA83591000	BRKT-FAN-TNR		1/1/P										
7	6LA34314000	FAN-D-8025-350NH		1/1/D										
8	6LA83586000	SEAL-FAN-SIDE		2/1/KP										
9	6LA83585000	SEAL-FAN-TOP		1/1/KP										
10	6LA83404000	FILTER-STAY-FRM-LFT		1/1/KP										
11	6LA84873000	SEAL-GLASS-LSU-C		1/1/KP										
13	6LA65141000	HLDL-SNSR-THS		1/1/P										
14	6LA89109000	SNSR-THS-371		1/1/C										
16A	6LA89103000	PS-LVPS-371JU		1/1/C									NAD	
16B	6LA89104000	PS-LVPS-371E		1/1/C									MJD,ASD,AU D	
17	6LA08909000	S/TPS/HEX-3*8-NI		7/10/P										
18	6LA08913000	S/TPS/HEX-4*8-NI		9/10/P										
19	6LA85763000	LASER-UNIT-371		1/1/S										
20	6LA36749000	ASYS-SCREW-LSU-NI		3/5/P										
21	6LA83406000	SPL-FG-LSU-B		1/1/P										
101	F0-00045000	EDS-1		1/10/P										
102	F0-00313000	SPLSN-18U		2/5/P										
103	F0-01299000	LWS-2111Z		3/1/P										
104	X0-02114000	S/TPS/PAN-4X32-ZU3		2/10/P										
105	F0-00043000	UAMS-05SN-W		1/5/P										
106	X0-02034000	S/TPP/PAN-3X12-NI		1/10/P										
108	F0-01286000	FCR-30		2/5/P										
110	F0-00044000	UAMS-05-2		1/5/P										

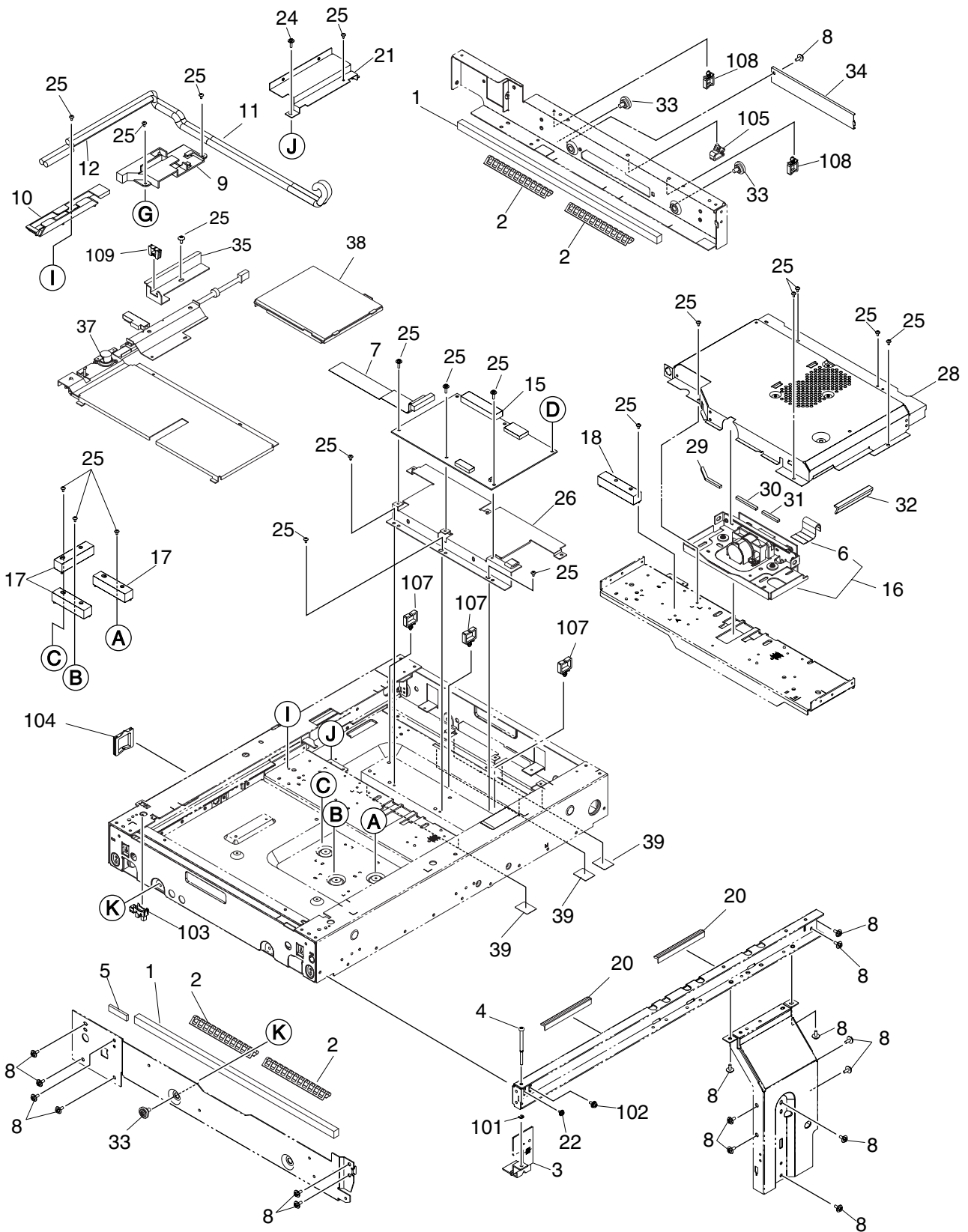

ITEM NO.	PARTS NO.	PARTS NAME	Q'TY / PAGE	Q'TY / PACK	PIR	BSI NO.	TO	T	FROM	SERIAL NO.	REMARKS	C
1	6LA67800000	CUSH-STAY-TP-LFT		21/KP								
2	6LA39931000	SPL-SHLD-102-7		41/KP								
3	6LA67468000	BRKT-ADJT-TP-FRT-360		11/P								
4	6LA67500000	SCREW-ADJT-FRM		11/P								
5	6LA67810000	CUSH-STAY-TP-LFT-S		11/KP								
6	6LA71418000	HRNS-CCD-360		11/KP								
7	6LA89478000	HRNS-SLG-SYS-371		11/P								
8	6LA08913000	S/TPS/HEX-4*8-NI		1910/P								
9	6LA39661000	DUCT-SCAN-INR		11/P								
10	6LA39385000	GUIDE-HRNS-RER		11/P								
11	6LA71384000	HRNS-SNSR-SCN-360		11/P								
12	6LA89466000	HRNS-SLG-SPLY-371		11/P								
13	6LA89468000	HRNS-ADF-371		11/P								
14	6LA71386000	HRNS-SCN-MOT-360		11/P								
15	6LA89808000	ASY-SLG-371S		11/P								
16	6LA85765000	LENS-UNIT-371		11/S								
17A	44205167000	SNSR-PS-TW05		31/C							NAD	
17B	44205167000	SNSR-PS-TW05		41/C							MJD, ASD, AU D, CND, TWD	
18	4406379920	SNSR-PS-TY1CH56		11/D								
19A	6LA71425000	HRNS-APS-L-360		11/P							NAD	
19B	6LA71424000	HRNS-APS-A-360		11/P							MJD, ASD, AU D, CND, TWD	
20	6LA86470000	GSKT-L10-100		21/KP								
21	6LA39453000	COVER-HRNS-SLG		11/P								
22	6LA08932000	SCREW-ACTR-TRU		210/P								
23	6LA08908000	S/TPS/HEX-3*6-NI		5910/P								
24	6LA08909000	S/TPS/HEX-3*8-NI		410/P								
25	6LA08935000	SCR-M3X6BISR-NI		2510/P								
26	6LA86485000	ASYS-BRKT-PWA-SLG-371		11								
28	6LA39656000	ASYS-COVER-LENS-350		11/PP								
29	6LA39815000	GASKET-COV-LENS		11/KP								
30	6LA39814000	GASKET-3-4-38		11/P								
31	6LA39813000	GASKET-3-4-30		11/P								
32	6LA39816000	GASKET-LS13-8		11/P								
33	6LA67453000	ASY-SCREW-SCAN		35/P								
34	6LA39881000	LID-DOWNLOAD		11/P								
35B	6LA39898000	BRKT-D_H-LENS		11/P							ASD, AUD, CN D	
37B	6LA39893000	ASY-D-H-SCAN-L-E		11/C							ASD, AUD, CN D	
38B	6LA39903000	ASY-D-H-SCAN-R-E		11/C							ASD, AUD, CN D	
101	X0-00964000	RR/E-3-SS		110/P								
102	X0-00164000	S/PAN/SWWP-M4X8-NI		110/P								
103	C0-07598000	GP1A73AR		11/P								
104	F0-00034000	EDS-2323U		15/P								
105	F0-00664000	MWC-2S		11/P								
106	X0-00077000	S/PAN/SWWP-M3X8-NI		510/P								
107	F0-01179000	WWS-2U		35/P								
108	F0-00338000	WS-2U		25/P								
109B	F0-00339000	EHP-6U		15/P							ASD, AUD, CN D	

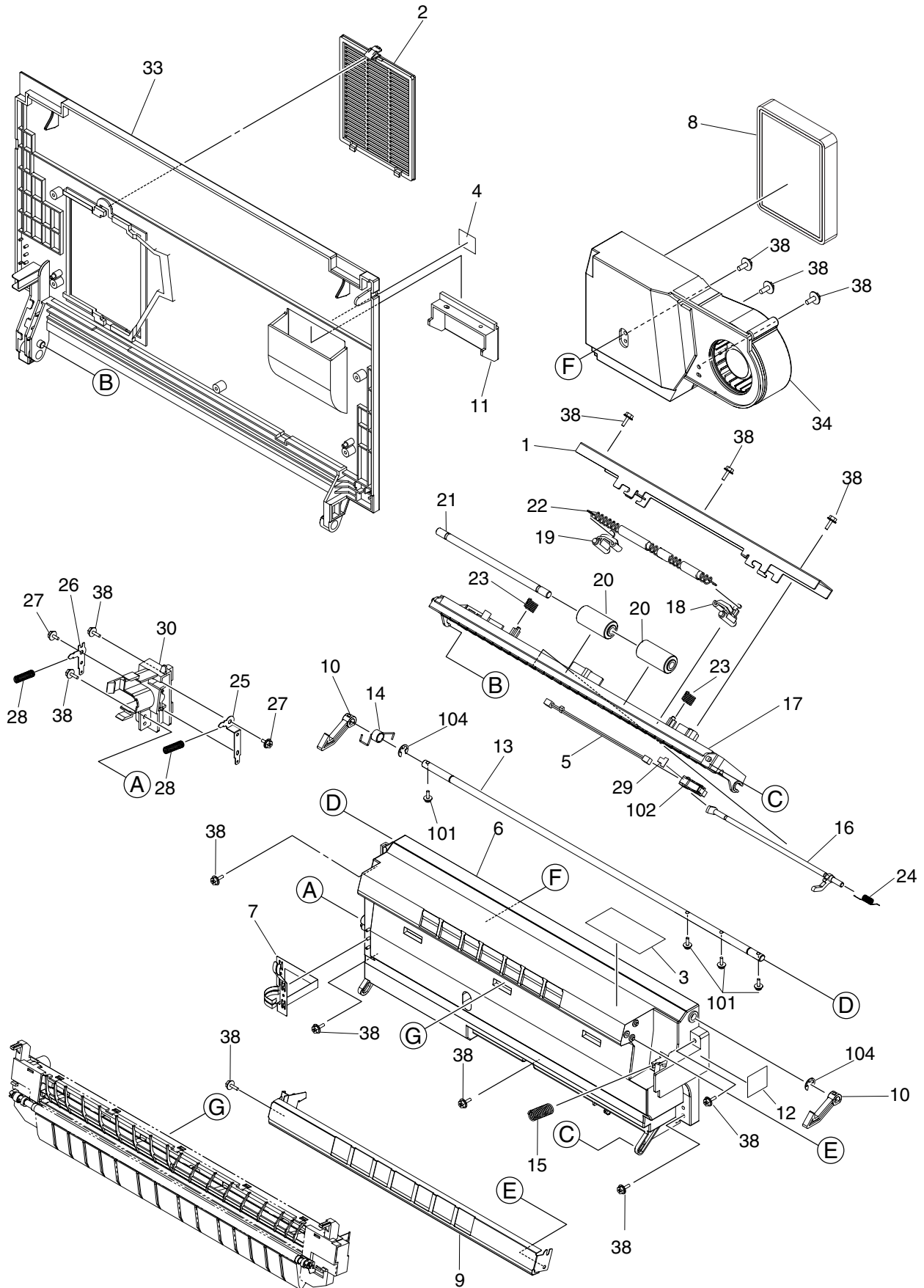

ITEM NO.	PARTS NO.	PARTS NAME	Q'TY / PAGE	Q'TY / PACK	P	I	R	B S I NO.	T O	T	F R O M	S E R I A L NO.	R E M A R K S	C
1	6LA88203000	STAY-REALY-FEED		1/1/P										
2	6LA88380000	ASYS-COV-FILTER		1/1/P										
3	44204544000	LABEL-DRUM-PS		1/1/KP										
4	6LA67028000	LBL-JAM-1		1/5/KP										
5	6LA89456000	HRNS-1STFED-SW-371		1/1/P										
6	6LA88320000	CASE-COV-SIDE		1/1/PP										
7	6LA88340000	EARTH-CASE-TR		1/1/P										
8	6LA88260000	ASYS-FILTER-OZN		1/1/C										MSP
9	6LA88337000	GUIDE-TR		1/1/P										
10	6LA88331000	HOOK-COV-SIDE		2/1/P										
11	6LA88328000	LEVER-COV-SIDE		1/1/P										
12	6LA37667000	LBL-O-RGST		1/5/P										
13	6LA88325000	SHAFT-LOCK-COV		1/1/P										
14	6LA88333000	SPA-HOOK		1/1/P										
15	6LA88343000	SPC-CH-TR		1/1/P										
16	6LA85825000	ACTR-RELAY-371		1/1/KP										
17	6LA88316000	GUIDE-RELAY-FED		1/1/P										
18	6LA88317000	LVR-SEP-RELAY-F-371		1/1/P										
19	6LA88318000	LVR-SEP-RELAY-R-371		1/1/P										
20	6LA85834000	ROL-RELAY-FEED-IDL		2/1/P										
21	6LA85835000	SHAFT-RELAY-IDL		1/1/P										
22	6LA85844000	SPG-FEED-IDL		1/1/P										
23	6LA85845000	SPG-RELAY-GUIDE		2/5/P										
24	6LA85826000	SPR-ACT-RELAY-371		1/1/P										
25	6LA88308000	PLT-CH-S		1/1/P										
26	6LA88309000	PLT-CH-T		1/1/P										
27	6LA08916000	S/TPP/HEX-3X6-NI		2/10/P										
28	6LA88313000	SPC-TERM-CH-TR		2/5/P										
29	6LA85910000	MYLAR-SUPPORT-SNS		1/5/P										
30	6LA88305000	TERM-HVT-TR		1/1/P										
33	6LA88314000	ASYS-COV-SIDE		1/1/PP										
34	6LA88348000	ASY-COV-DUCT		1/1/C										
38	6LA08917000	S/TPP/HEX-3*8-NI		14/10/P										
101	X0-00077000	S/PAN/SWWP-M3X8-NI		4/10/P										
102	C0-07598000	GPLA73AR		1/1/P										
104	X0-00966000	RR/E-5-SS		2/10/P										

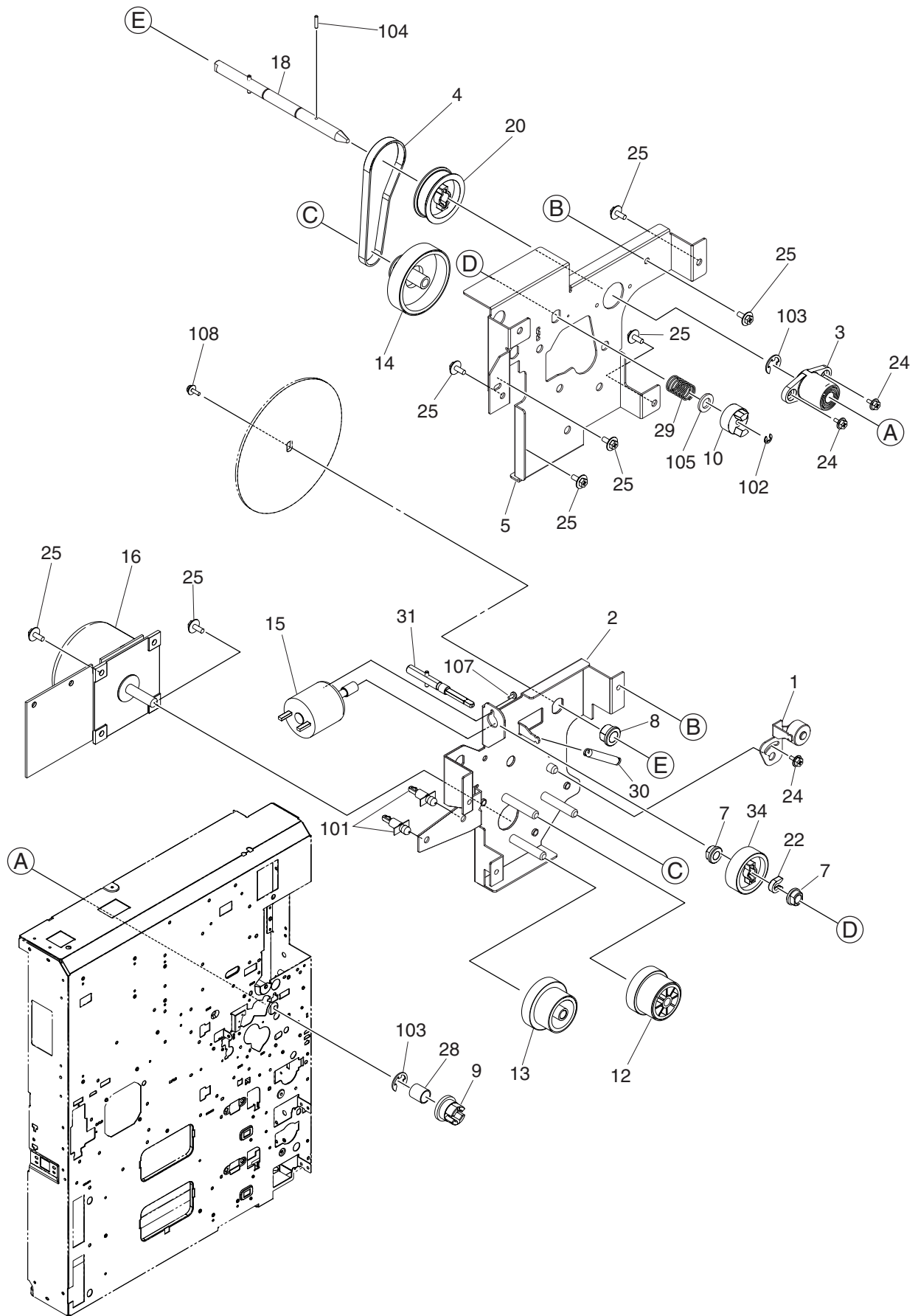

ITEM NO.	PARTS NO.	PARTS NAME	Q'TY / PAGE	Q'TY / PACK	P	I	R	B S I NO.	T O	T	F R O M	S E R I A L NO.	R E M A R K S	C
1	6LA82257000	ASYB-BLT-TENS-DRM		1/1/P										
2	6LA82203000	ASYS-BRKT-DRV-R-BLT		1/1/P										
3	6LA82214000	ASYS-BUSH-DRUM		1/1/P										
4	6LA82230000	BLT-SY-S2M-224-6		1/1/P										
5	6LA82205000	BRKT-DRV-F-A		1/1/P										
7	44201492000	BUSH-6-POM		2/5/P										
8	6LA65698000	BUSH-8X12X8F		1/5/P										
9	41314022000	CPG-DRUM-AW5		1/1/P										
10	41306070000	CPG-TC-AT5		1/1/P										
12	6LA82225000	GEAR-5H61-8H33-6		1/1/P										
13	6LA82217000	GEAR-5H67-8H31-6		1/1/P										
14	6LA82241000	GEAR-8H56-PS2M26-6		1/1/P										
15	41309035000	M/DC-TNR-AW		1/1/C										
16	6LA82209000	MOTR-D-MAIN-371		1/1/C										
18	6LA82249000	ASYS-SFT-DRUM-371		1/1/P										
20	6LA82245000	PULLEY-PS2M54-6		1/1/P										
22	4407972860	STOP-RING-6-5		1/5/P										
24	6LA08908000	S/TPS/HEX-3*6-NI		3/10/P										
25	6LA08913000	S/TPS/HEX-4*8-NI		8/10/P										
28	6LA82235000	SPG-C-10R7X14R7R		1/5/P										
29	6LA82237000	SPG-C-11R8*R8*24L-TC		1/1/P										
30	6LA82233000	SPG-E-5XR55X29R37-TNS		1/1/P										
31	6LA82251000	ASYS-SFT-DRV-TNR		1/1/P										
34	6LA82234000	WHEEL-WORM-TNR		1/1/P										
101	F0-00343000	SPLSN-8U		2/5/P										
102	X0-00964000	RR/E-3-SS		1/10/P										
103	X0-00968000	RR/E-7-SS		2/10/P										
104	X0-00980000	P/PRL/AH7-2X10-SS		1/10/P										
105	X0-00922000	W/PL/SJ0-8-ZC		1/5/P										
107	X0-01670000	S/PAN-M2.6X4-NC		1/10/P										
108	X0-00077000	S/PAN/SWWP-M3X8-NI		1/10/P										

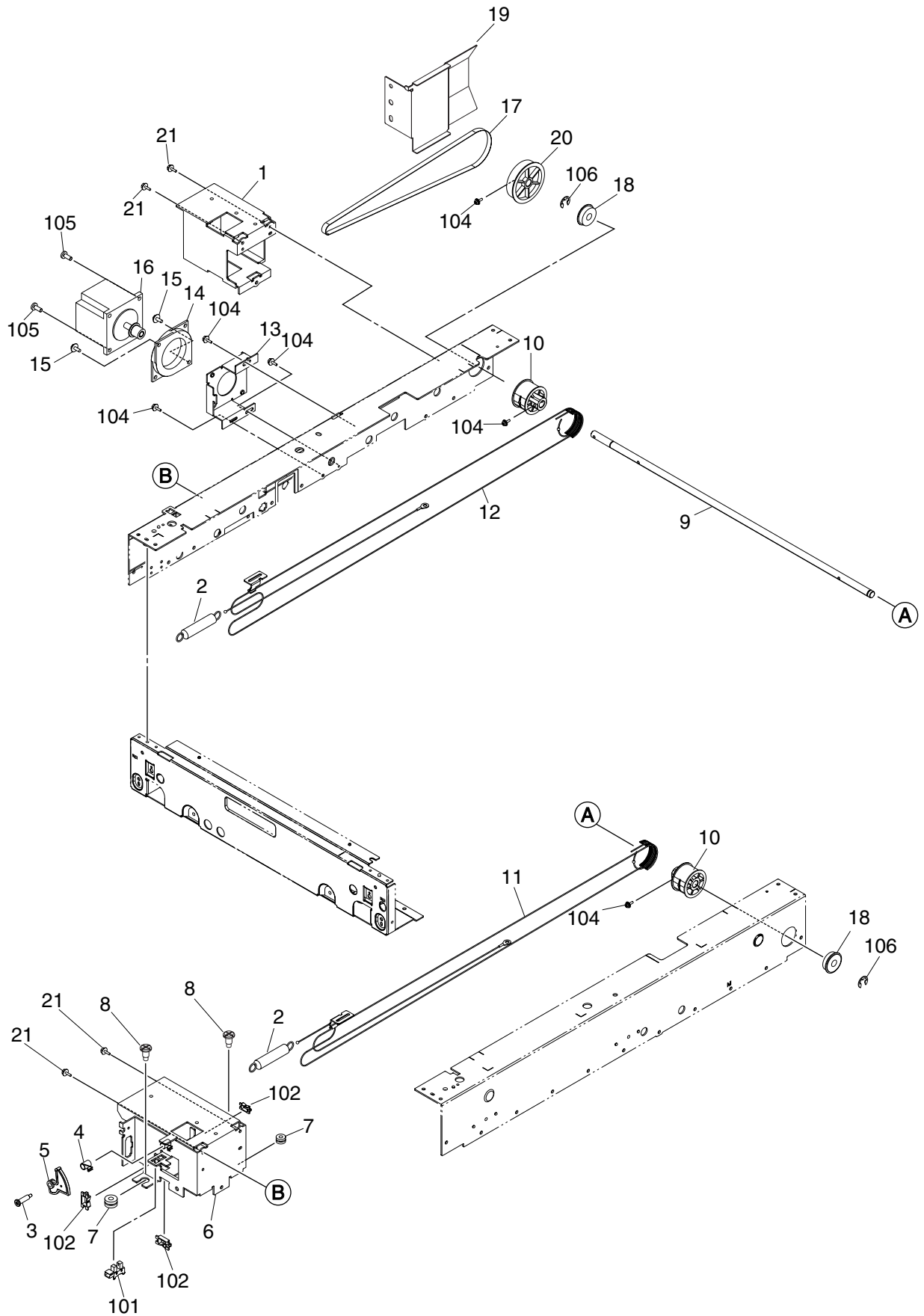

ITEM NO.	PARTS NO.	PARTS NAME	Q'TY / PAGE	Q'TY / PACK	P I R	B S I NO.	T O	T	F R O M	S E R I A L NO.	R E M A R K S	C
1	6LA39782000	BRKT-DF-RGT-350		11/P								
2	44202660000	SPE-WIRE-TENS		21/P								
3	6LA67393000	SHAFT-OPN-SNS		11/P								
4	44202846000	SPR-OPEN-SNS		11/P								
5	44202845000	LVR-OPEN-SNS		11/P								
6	6LA86452000	BRKT-DF-LFT-SCAN		11/P								
7	6LA39794000	GROMMET-DF		25/P								
8	6LA67469000	SCREW-SCAN-DF		25/P								
9	6LA39397000	SHAFT-DRV-SCAN		11/P								
10	6LA01742000	PLY-WIRE-SCAN		21/P								
11	6LA39410000	ASYS-WIR_RP-SCAN-FRT		11/P								
12	6LA39430000	ASYS-WIR_RP-SCAN-RER		11/P								
13	6LA39733000	BRKT-MOTR-SCAN		11/P								
14	6LA39739000	DUMPER-MOTR		11/P								
15	6LA08913000	S/TPS/HEX-4*8-NI		210/P								
16	6LA67446000	ASYS-MOTR-SCAN		11/C								
17	6LA39745000	BLT_SY-560-S2M-6		11/P								
18	4407545610	BRG-608ZZNR		21/P								
19	6LA39784000	COVER-PILLEY		11/P								
20	6LA39444000	PULLEY-73S2M		11/P								
21	6LA08909000	S/TPS/HEX-3*8-NI		410/P								
101	C0-07598000	GP1A73AR		11/P								
102	F0-00041000	EDS-2		310/P								
104	X0-00077000	S/PAN/SWWP-M3X8-NI		310/P								
105	X0-00455000	S/BID-M4X10-NI		210/P								
106	X0-00968000	RR/E-7-SS		210/P								

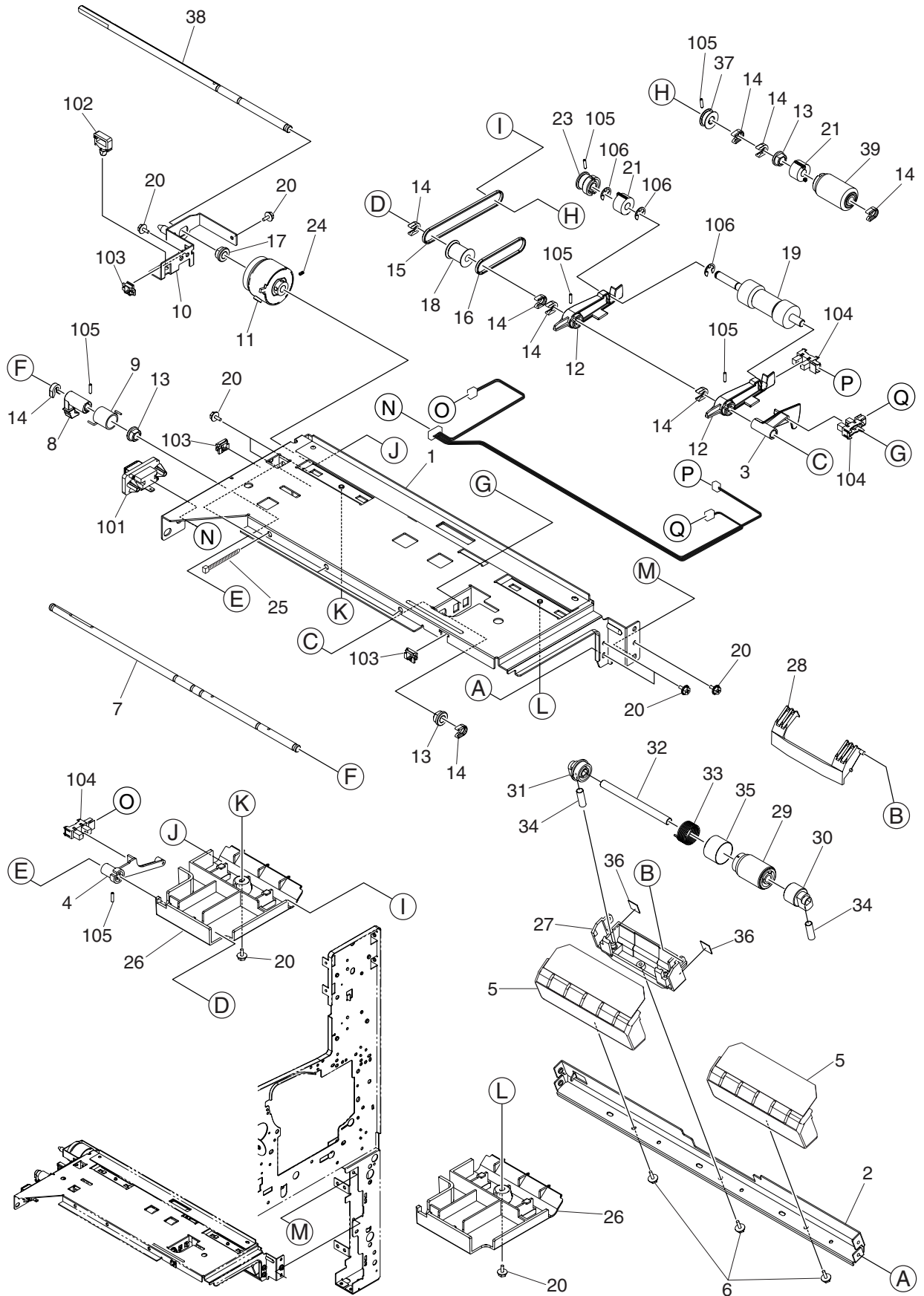

ITEM NO.	PARTS NO.	PARTS NAME	Q'TY / PAGE	Q'TY / PACK	PIR	BSI NO.	TO	T	FROM	SERIAL NO.	REMARKS	C
1	6LA47892000	ASYS-BRKT-FEED-UNIT		1/1/PP								
2	6LA47898000	BRKT-ROL-SEP		1/1/P								
3	41306012000	ACTR-EMPTY-PPR		1/1/P								
4	41318603000	ARM-FEED-UNIT		1/1/P								
5	6LA66947000	ASYS-GUIDE-P-SEP		2/1/KP								
6	6LA08917000	S/TPP/HEX-3*8-NI		3/10/P								
7	41318604000	SFT-DRV-PICK		1/1/P								
8	6LA47910000	LEVER-RLR-PICK		1/1/P								
9	41305501000	SPR-LVR-PICK		1/1/P								
10	6LA47895000	ASYS-BRKT-CLT		1/1/P								
11	6LA31944000	CLUTCH-33C-6-CW-GEAR		1/1/D								
12	41306011000	ARM-RLR-PICK		2/1/P								
13	44201492000	BUSH-6-POM		3/5/P								
14	4407972860	STOP-RING-6-5		9/5/P								
15	41306504000	BLT/T-194-2GT-2		1/1/P								
16	41306502000	BLT/T-124-2GT-2		1/1/P								
17	4407734980	BUSH-6-GCB		1/5/P								
18	41306002000	PLY/T-PICK-20		1/1/P								
19	41306719000	ROLLER-PICK-AT		1/1/KP								MSP
20	6LA08908000	S/TPS/HEX-3*6-NI		10/10/P								
21	4406584800	CLUTCH-6-08L2		2/1/P								
22	6LA41754000	HRNS-PFP-FED-UNIT-576		1/1/P								
23	41306275000	PLY/T-20-2GT		1/1/P								
24	X0-00730000	S/SET/K-M3X4-B		1/10/P								
25	4400682590	SKB-KI-100M		4/5/P								
26	6LA47908000	GUIDE-P-FEED		2/1/P								
27	44201805000	HLDR-SEP-ROL-DM		1/1/P								
28	44201810000	LEV-ROL-SEP-DM		1/1/P								
29	41304047100	K-ROLL-SPT		1/1/P								MSP
30	41306279000	ARBOR-SPT-F		1/1/P								
31	41306278000	ARBOR-SPT-R		1/1/P								
32	41304506000	SFT-SEP-AT		1/1/P								
33	44201817000	SPR-1.0-15.60RF		1/5/P								
34	6LA47909000	SPC055-045-01525		2/5/P								
35	44201773000	COV-SPE/ARBOR		1/1/P								
36	41319491000	CHIP-HLDR-SEP		2/1/P								
37	41306274000	PLY/T-20-ROL-2G		1/1/P								
38	6LA47900000	SFT-ROL-FEED		1/1/P								
39	4401964410	K-ROLL-FEED		1/1/P								MSP
101	E0-01105000	54702-1211		1/5/P								
102	F0-00235000	LWS-1S		1/5/P								
103	F0-00671000	EDS-0607M		3/5/P								
104	C0-07598000	GP1A73AR		3/1/P								
105	X0-00979000	P/PRL/AH7-2X8-SS		5/10/P								
106	X0-00966000	RR/E-5-SS		3/10/P								

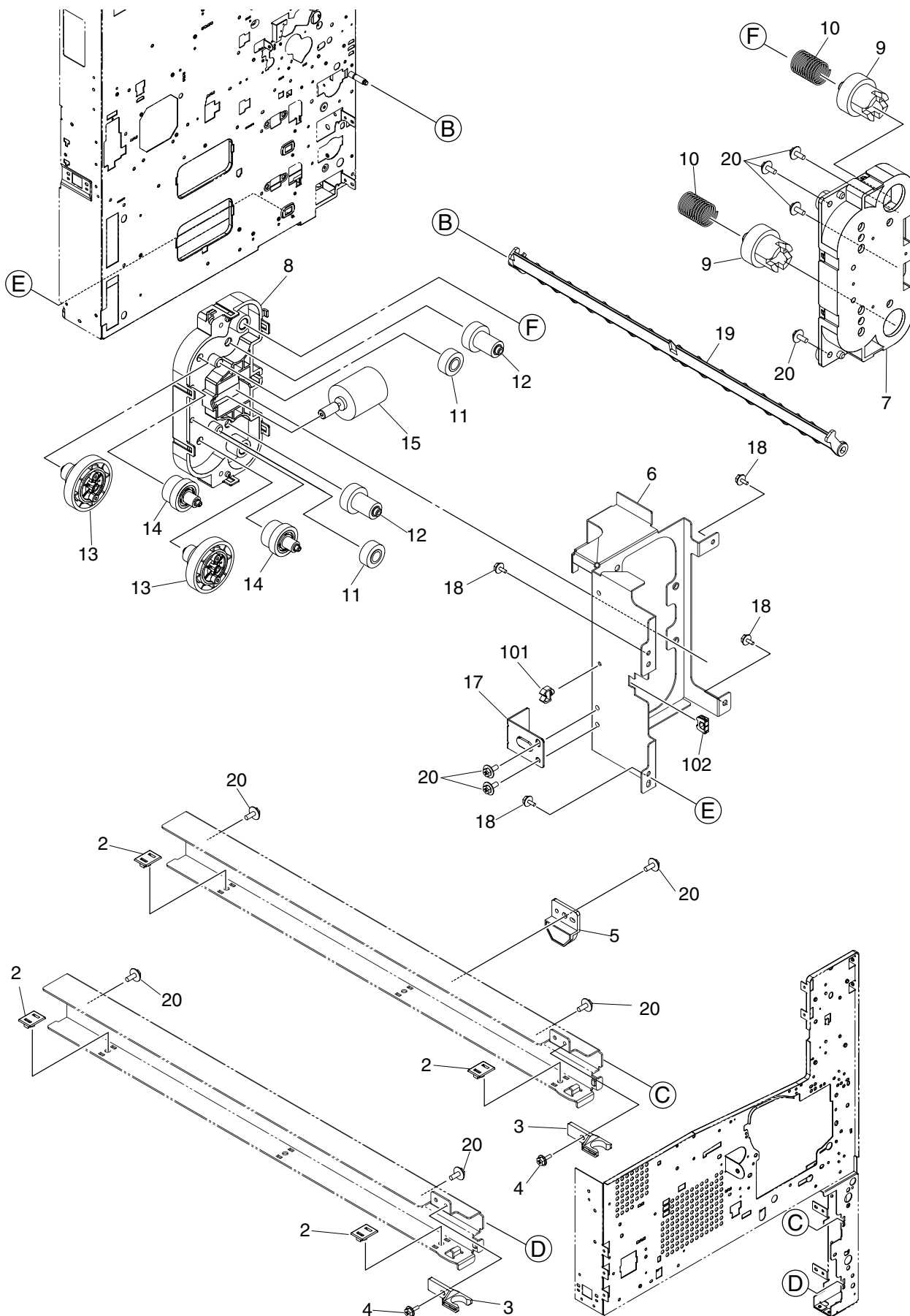

ITEM NO.	PARTS NO.	PARTS NAME	Q'TY / PAGE	Q'TY / PACK	PIR	BSI NO.	TO	T	FROM	SERIAL NO.	REMARKS	C
2	41306007000	SLIDER-CST		41/P								
3	44201601000	CATCH-CST-320		21/P								
4	6LA08909000	S/TPS/HEX-3*8-NI		210/P								
5	6LA82867000	HOLDER-FEEDER-371		11/P								
6	6LA83063000	BRKT-TRAY-UP-MOT		11/P								
7	44201850000	CASE-DRV-TRY-F		11/D								
8	44201851000	CASE-DRV-TRY-R		11/C								
9	41306022000	CPG-LIFT-28		21/P								
10	4401966050	SPC172-100-3400		21/P								
11	41306025000	GER-TRAY-21		21/P								
12	41306024000	GER-TRAY-24-14		21/P								
13	44201853000	G06S-13/G05S-80		21/P								
14	44201854000	G05H-45/G05S-15		21/P								
15	4401981710	K-M/DC-TRAY-210		11/D								
17	6LA81314000	BRKT-PCI-371		11/P								
18	6LA08908000	S/TPS/HEX-3*6-NI		410/P								
19	6LA79064000	GUIDE-JUNCTION-371		11/P								
20	6LA08913000	S/TPS/HEX-4*8-NI		1310/P								
101	F0-00043000	UAMS-05SN-W		15/P								
102	F0-00339000	EHP-6U		15/P								

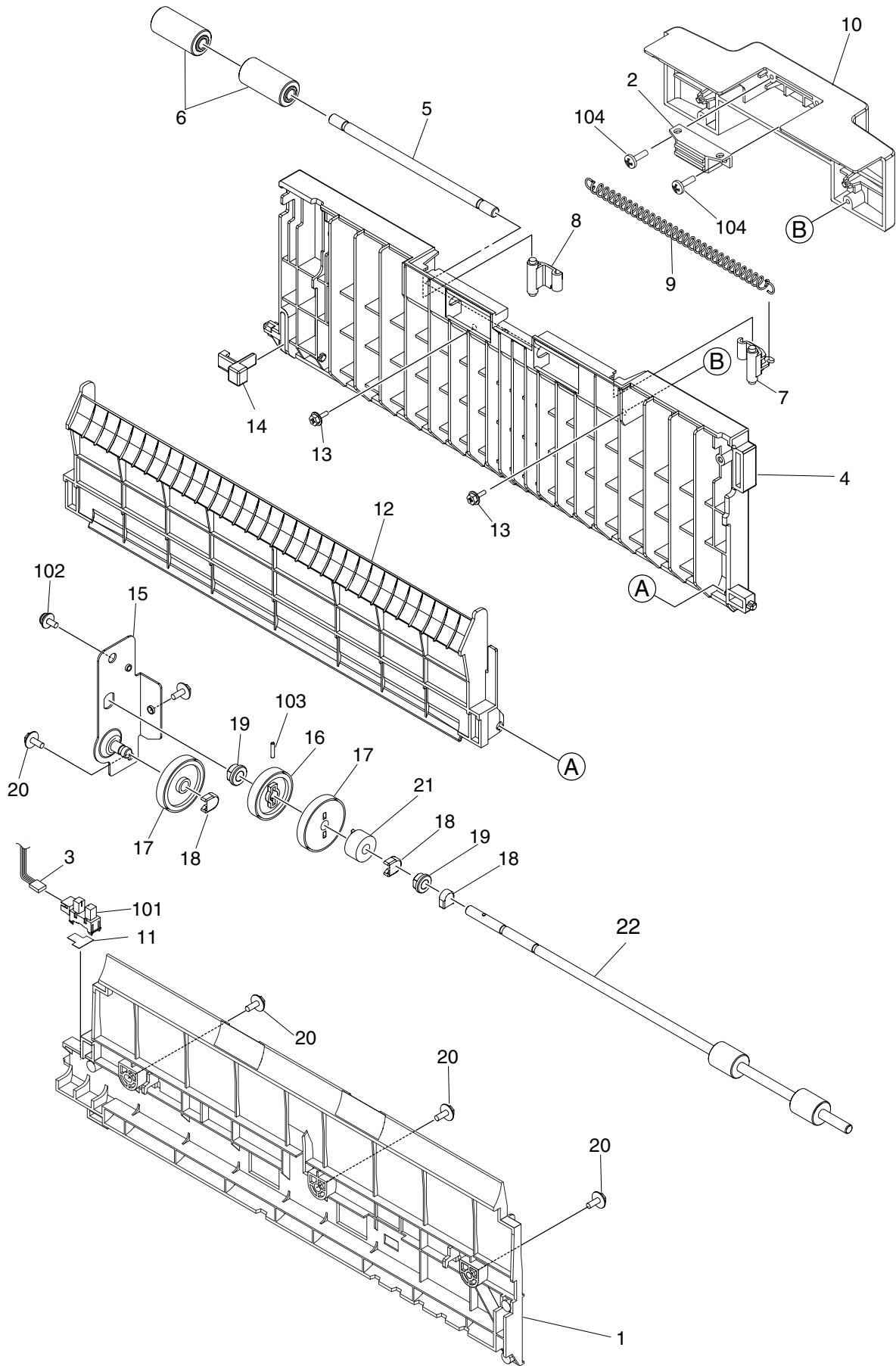

ITEM NO.	PARTS NO.	PARTS NAME	Q'TY / PAGE	Q'TY / PACK	P I R	B S I NO.	T O	T	F R O M	S E R I A L NO.	R E M A R K S	C
1	6LA82818000	ASYS-GID-FEED-L-371		1/1/PP								
2	44200424000	MG-CATCH-44		1/1/P								
3	6LA89459000	HRNS-CST-SDCV-371		1/1/P								
4	6LA82822000	COVER-GUIDE-LOW-371		1/1/PP								
5	6LA85835000	SHAFT-RELAY-IDL		1/1/P								
6	6LA85834000	ROL-RELAY-FEED-IDL		2/1/P								
7	6LA88317000	LVR-SEP-RELAY-F-371		1/1/P								
8	6LA88318000	LVR-SEP-RELAY-R-371		1/1/P								
9	6LA82827000	SPG-E-6R7XR7X79R55		1/1/P								
10	6LA82823000	COVER-GUIDE-LOW-HDL		1/1/PP								
11	6LA85910000	MYLAR-SUPPORT-SNS		1/5/P								
12	6LA82824000	GUIDE-OPEN-L-371		1/1/PP								
13	6LA08917000	S/TPP/HEX-3*8-NI		2/10/P								
14	6LA82825000	STOPPER-COV-GID-371		1/1/PP								
15	6LA83092000	ASYS-BRKT-DRV-FIX		1/1/P								
16	6LA83114000	GEAR-10S028-06		1/1/P								
17	6LA83111000	GEAR-10S031-06		2/1/P								
18	4407972860	STOP-RING-6-5		3/5/P								
19	4407734980	BUSH-6-GCB		2/5/P								
20	6LA08913000	S/TPS/HEX-4*8-NI		5/10/P								
21	4406584800	CLUTCH-6-08L2		1/1/P								
22	6LA83001000	ROL-FEEDER-371		1/1/KP								
101	CO-07598000	GP1A73AR		1/1/P								
102	X0-00164000	S/PAN/SWWP-M4X8-NI		1/10/P								
103	X0-00980000	P/PRL/AH7-2X10-SS		1/10/P								
104	X0-01989000	S/TPP/BID-3X8-NI		2/10/P								

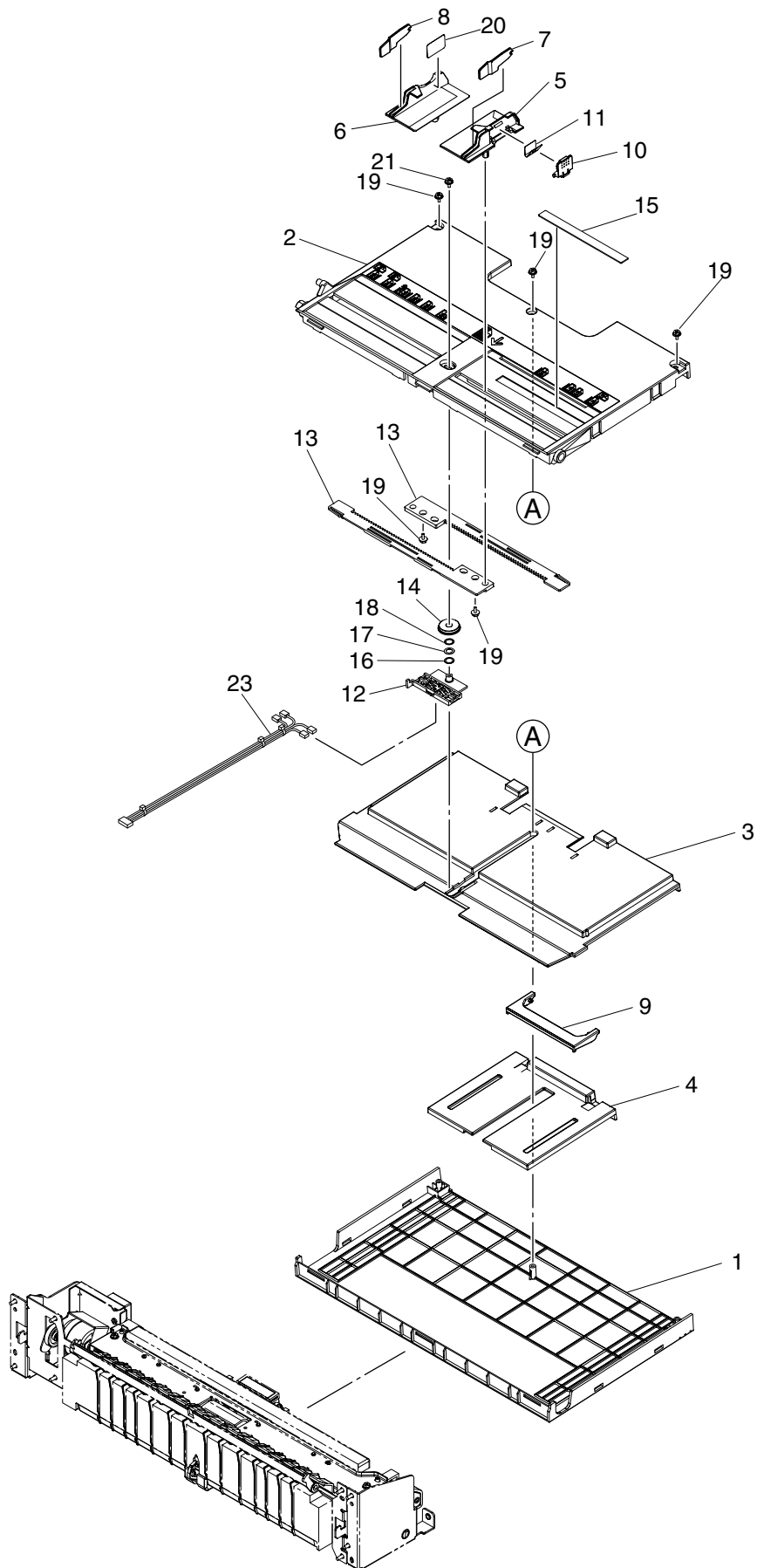

ITEM NO.	PARTS NO.	PARTS NAME	Q'TY / PAGE	Q'TY / PACK	P I R	B S I NO.	T O	T	F R O M	S E R I A L NO.	R E M A R K S	C
1	6LA79092000	TRAY-BYPASS-L-371		1/1/PP								
2	6LA79093000	TRAY-BYPASS-U-371		1/1/PP								
3	6LA79101000	TRAY-BYP-MID		1/1/PP								
4	6LA64859000	TRAY-BYP-M-SUB		1/1/D								
5	6LA79094000	GUIDE-TRAY-BYP-F-371		1/1/P								
6	6LA79095000	GUIDE-TRAY-BYP-R-371		1/1/P								
7	6LA79102000	GUIDE-SUB-F-371		1/1/P								
8	6LA79103000	GUIDE-SUB-R-371		1/1/P								
9	6LA64856000	STOP-PAPER-BYP		1/1/P								
10	6LA79104000	LVR-GUIDE-F-371		1/1/P								
11	6LA79105000	SPG-GUIDE-F-371		1/1/P								
12	44218419000	K-HOLDER-PINI		1/1/P								
13	6LA79096000	RACK-BYP-371		2/1/PP								
14	4407726480	PINION-18-395		1/1/P								
15	6LA29009000	SHEET-PAD-GUIDE-F		1/1/KP								
16	F0-01324000	STW-FT60 T0.25		1/1/P								
17	4400974200	WASHER-W-6-10		1/10/P								
18	F0-01323000	STW-FT-60 T0.13		1/1/P								
19	6LA08916000	S/TPP/HEX-3X6-NI		5/10/P								
20	6LA91348000	LBL-HIGH-TRAY-371		1/5/P								
21	6LA08917000	S/TPP/HEX-3*8-NI		1/10/P								
23	6LA89429000	HRNS-SFB-SIZE-371		1/1/P								

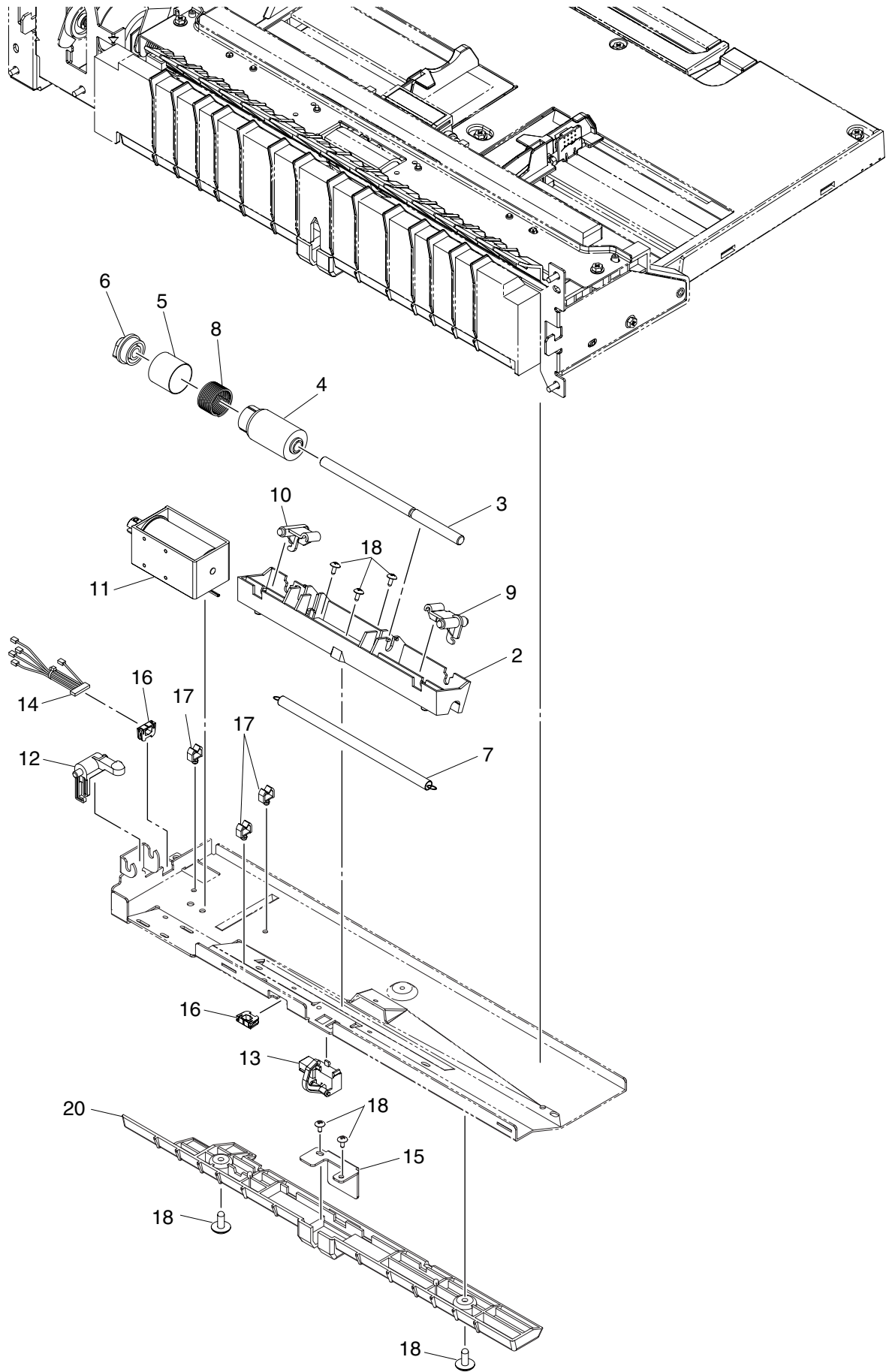

ITEM NO.	PARTS NO.	PARTS NAME	Q'TY / PAGE	Q'TY / PACK	PIR	BSI NO.	TO	T	FROM	SERIAL NO.	REMARKS	C
2	6LA78957000	HLDL-SPT-BYP-371		1/1/P								
3	6LA78962000	SHAFT-SPT-BYP-371		1/1/P								
4	6LA28899000	ASYS-ROLL-SPT-L30		1/1/P								MSP
5	6LA28861000	COVER-SPE-ARBOR-17		1/1/P								
6	6LA28863000	ARBOR-SPT-BYP		1/1/P								
7	6LA28840000	SPG-E-6XR6X91R7R		1/1/P								
8	6LA28865000	SPG-1.0-0.15-65-13L		1/1/P								
9	6LA78959000	LVR-SPT-BYP-F-371		1/1/P								
10	6LA78960000	LVR-SPT-BYP-R-371		1/1/P								
11	6LA04769000	SOL-SFB-340		1/1/P								
12	6LA78981000	LVR-PICKUP-SOL-371		1/1/P								
13	4401983080	SZ-FED-210		1/1/P								
14	6LA89430000	HRNS-SFB-371		1/1/P								
15	6LA78941000	BRKT-MG-CATCH-371		1/1/P								MSP
16	F0-00339000	EHP-6U		2/5/P								
17	F0-00044000	UAMS-05-2		3/5/P								
18	6LA08935000	SCR-M3X6BISR-NI		7/10/P								
19	6LA08900000	S/HEX-M3*6-NI		2/10/P								
20	6LA78931000	GUIDE-FEED-L-SNS		1/1/P								

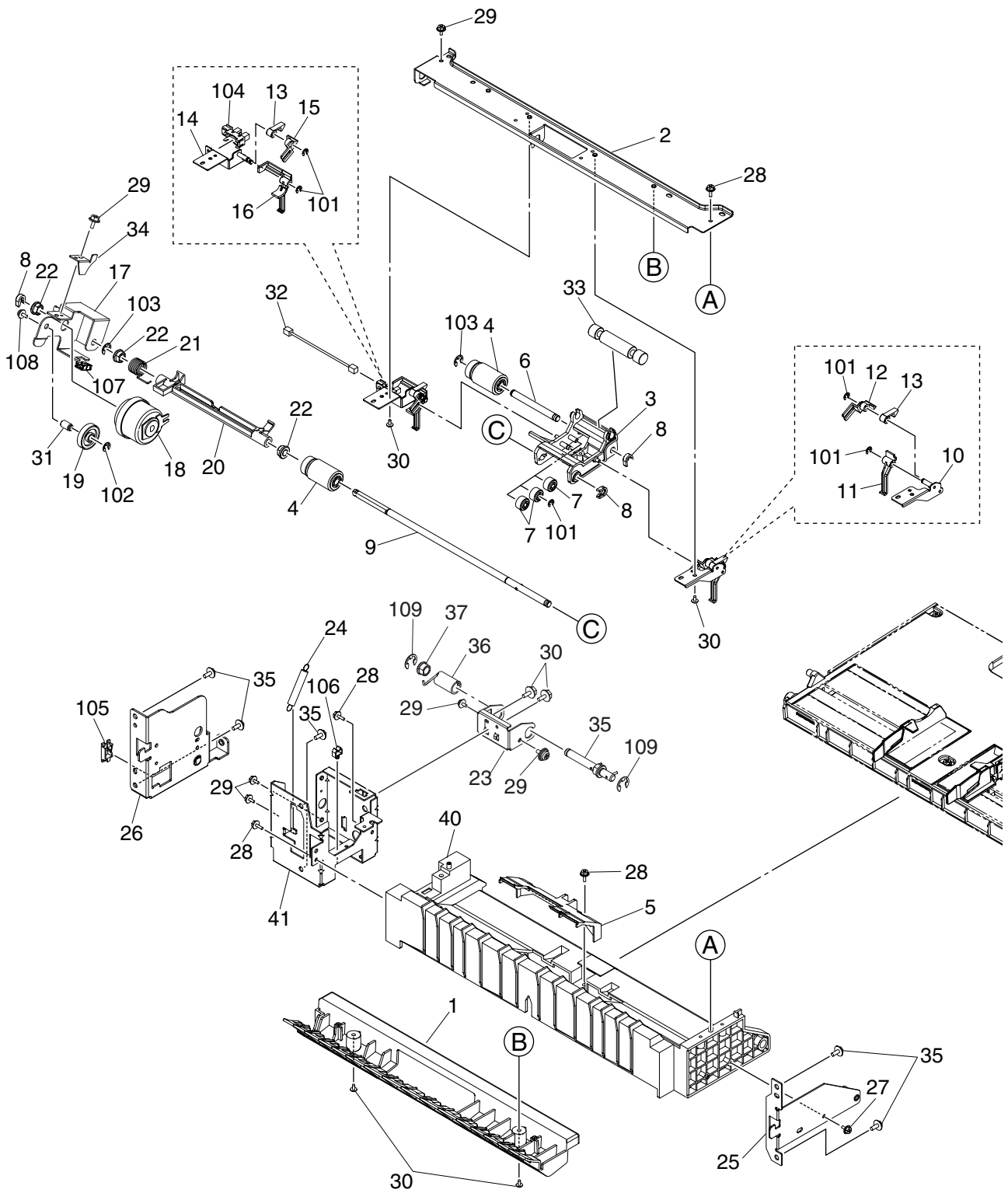

ITEM NO.	PARTS NO.	PARTS NAME	Q'TY / PAGE	Q'TY / PACK	P I R	B S I NO.	T O	T	F R O M	S E R I A L NO.	R E M A R K S	C
1	6LA79063000	GUIDE-BYP-UP-371		11/PP								
2	6LA79065000	STAY-BYP-U-371		11/P								
3	6LA79033000	ARM-PICK-371		11/P								
4	6LA79037000	ASYS-ROL-PICK-371		21/P								MSP
5	6LA78904000	ASYS-LID-FRAME-BYP-371		11/PP								
6	6LA79067000	SHAFT-PICK-UP-BYP		11/P								
7	6LA79034000	GEAR-06S018-04		31/P								
8	4407972860	STOP-RING-6-5		35/P								
9	6LA79050000	ASYS-SFT-FEED-BYP		11/P								
10	6LA79025000	ASYS-BKT-STOP-F		11/P								
11	6LA79024000	STPR-BYP-F-371		11/P								
12	4401965250	LEVER-STOPPER-F		11/P								
13	4401965270	ARM-STOPPER		25/P								
14	6LA79040000	ASYS-BRKT-STPR-R-371		11/P								
15	6LA79057000	LVR-STOPPER-R-371		11/P								
16	6LA79061000	STPR-BYP-R-371		11/P								
17	6LA79072000	ARM-DRV-JOINT-BYP-371		11/P								
18	6LA78512000	CLUTCH-G28-06D-35E		11/D								
19	6LA79005000	GEAR-10S022-06-DRV		11/P								
20	6LA79056000	LVR-PICK-JOINT		11/P								
21	6LA78980000	SPG-PICKUP-8-371		11/P								
22	4407734980	BUSH-6-GCB		35/P								
23	6LA79097000	HINGE-TRAY-R		11/P								
24	6LA34033000	SPG-E-6XR45X22R8		11/P								
25	6LA79081000	ASYS-BKT-TRAY-HINGE		11/P								
26	6LA78535000	ASYS-BRKT-HING-ADU-R		11/P								
27	6LA08916000	S/TPP/HEX-3X6-NI		110/P								
28	6LA08917000	S/TPP/HEX-3*8-NI		510/P								
29	6LA08908000	S/TPS/HEX-3*6-NI		510/P								
30	6LA08935000	SCR-M3X6BISR-NI		410/P								
31	6LA79073000	STUD-JOINT-BYP-371		11/P								
32	6LA89476000	HRNS-SFB-SNR-371		11/P								
33	6LA79076000	WEIGHT-ROLLER-PICK		11/P								
34	6LA79121000	COVER-JOINT-BYP		11/P								
35	6LA28766000	ASYS-SFT-TRAY-BYP-350		11/P								
36	6LA79112000	SPA-HINGE-BYP-371		11/P								
37	6LA65698000	BUSH-8X12X8F		15/P								
40	6LA78920000	ASYS-FRAME-BYP-371		11/PP								
41	6LA78923000	FRAME-SUB-BYP-371		11/PP								
101	X0-00964000	RR/E-3-SS		510/P								
102	X0-00965000	RR/E-4-SS		110/P								
103	X0-00966000	RR/E-5-SS		210/P								
104	C0-07598000	GPLA73AR		11/P								
105	F0-00041000	EDS-2		110/P								
106	F0-00044000	UAMS-05-2		15/P								
107	F0-00339000	EHP-6U		15/P								
108	X0-00060000	S/PAN/SWWP-M3X6-NI		110/P								
109	X0-00968000	RR/E-7-SS		210/P								

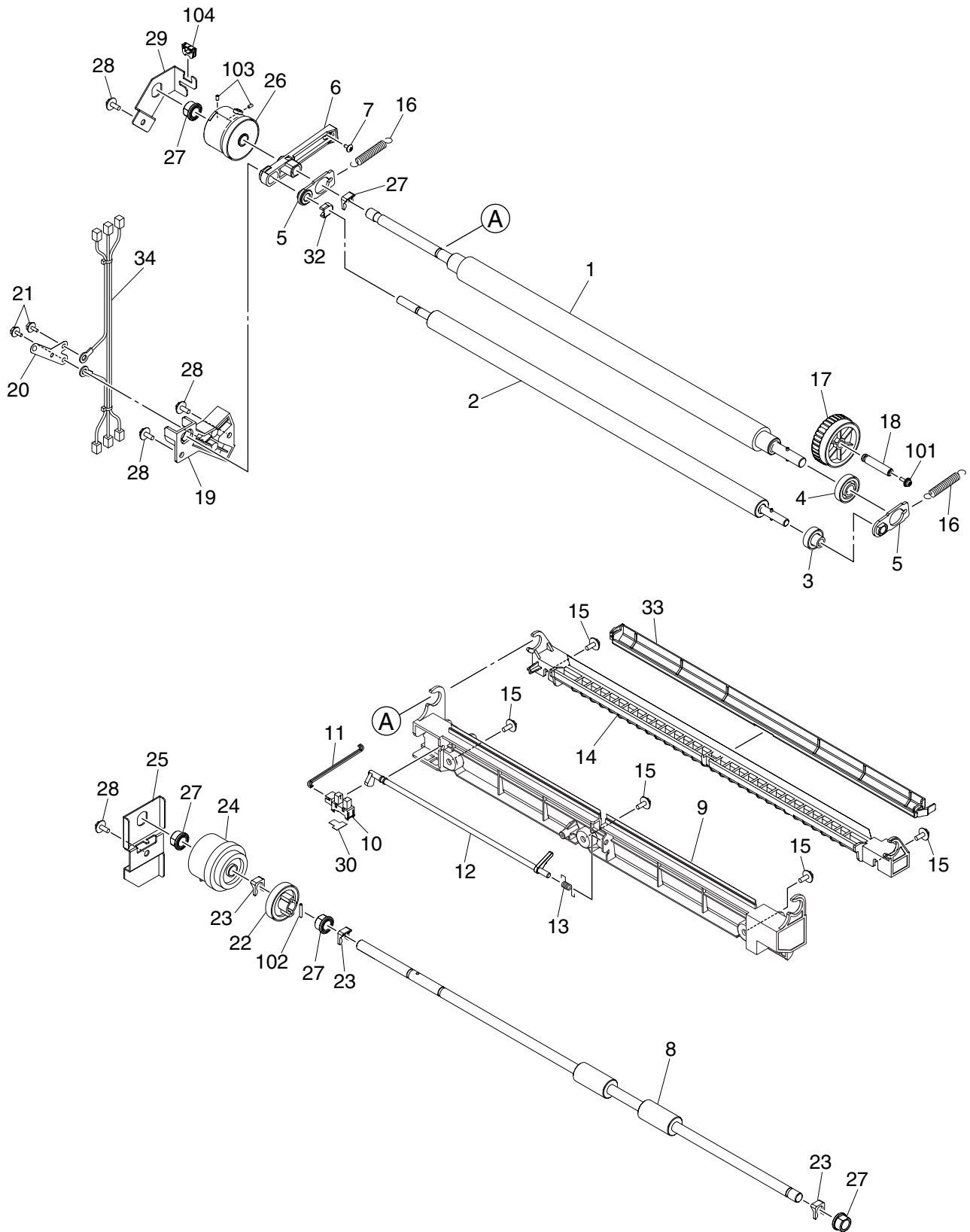

ITEM NO.	PARTS NO.	PARTS NAME	Q'TY / PAGE	Q'TY / PACK	P	I	R	BSI NO.	TO	T	FROM	SERIAL NO.	REMARKS	C
1	6LA85802000	ASYS-ROL-RGST		1/1/KP										
2	6LA85803000	ASYS-ROL-RGST-IDL		1/1/KP										
3	6LA85879000	GEAR-10S015-06		1/1/P										
4	6LA85880000	GEAR-10S020-08		1/1/P										
5	6LA85863000	PLT-RGST-TENS-371		2/1/P										
6	6LA85862000	HOLDER-RGST-R		1/1/P										
7	6LA08935000	SCR-M3X6BISR-NI		1/10/P										
8	6LA85813000	ROLLER-RELAY-FED		1/1/KP										
9	6LA85887000	ASYS-GID-RGST-L-371		1/1/P										
10	CO-07598000	GP1A73AR		1/1/P										
11	6LA89455000	HRNS-RGT-SW-371		1/1/P										
12	6LA85824000	ACTR-RGST-371		1/1/KP										
13	6LA85830000	SPG-ACT-RGST-371		1/1/P										
14	6LA85888000	ASYS-GID-RGST-R-371		1/1/P										
15	6LA08921000	S/TPP/HEX-4*8-NI		5/10/P										
16	6LA85864000	SPG-RGST-371		2/1/P										
17	6LA41229000	KNOB-RGST-350		1/1/P										
18	6LA85896000	STUD-KNOB-RGST-371		1/1/P										
19	6LA85871000	HOLDER-BIAS-RGST		1/1/P										
20	6LA85872000	SPL-BIAS-RGST		1/1/P										
21	6LA08916000	S/TPP/HEX-3X6-NI		2/10/P										
22	6LA85849000	GEAR-10S028-08		1/1/P										
23	4400336190	STOP-RING-8		4/5/P										
24	6LA82840000	CLUTCH-G28-08D-35E		1/1/D										
25	6LA85869000	BRKT-ROL-RELAY-FED		1/1/P										
26	6LA85810000	CLUTCH-G33-CW8		1/1/D										
27	6LA65698000	BUSH-8X12X8F		4/5/P										
28	6LA08913000	S/TPS/HEX-4*8-NI		4/10/P										
29	6LA85850000	BRKT-RGST-CLT-371		1/1/P										
30	6LA85910000	MYLAR-SUPPORT-SNS		1/5/P										
32	4407972860	STOP-RING-6-5		1/5/P										
33	6LA85828000	COVER-RGST-R-371		1/1/KP										
34	6LA89434000	HRNS-HVT-TCH-371		1/1/P										
101	X0-00077000	S/PAN/SWWP-M3X8-NI		1/10/P										
102	X0-01526000	P/PRL/AH7-2X12-SS		1/10/P										
103	X0-00730000	S/SET/K-M3X4-B		2/10/P										
104	F0-00339000	EHP-6U		1/5/P										

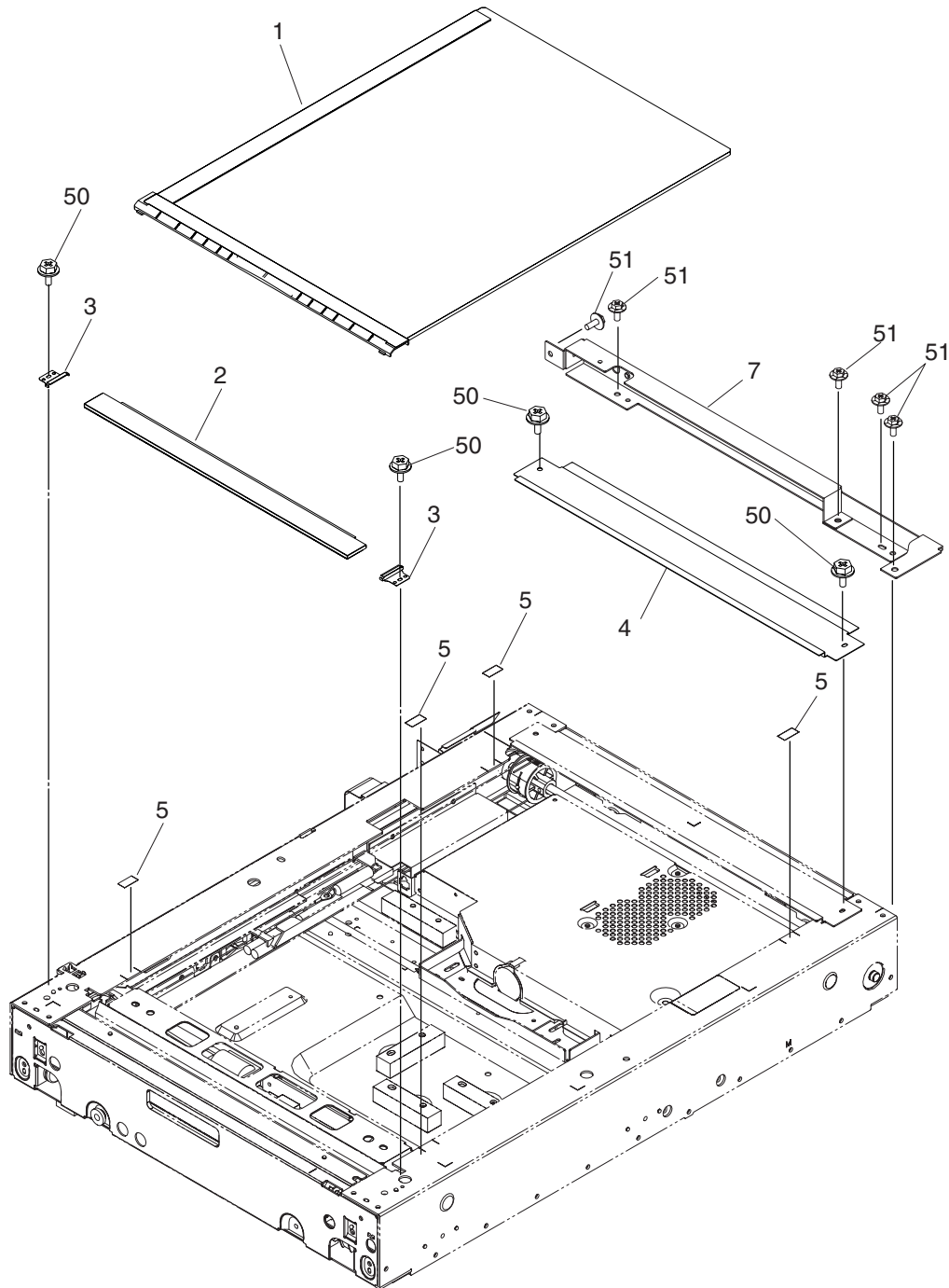

ITEM NO.	PARTS NO.	PARTS NAME	Q'TY / PAGE	Q'TY / PACK	P I R	B S I NO.	T O	T	F R O M	S E R I A L NO.	R E M A R K S	C
1A	6LA67425000	ASYS-GLASS-A		11/S							MJD, ASD, AU D, CND, TWD NAD	
1B	6LA67426000	ASYS-GLASS-L		11/S								
2	6LA67448000	ASYS-GLASS-ADF		11/PP								
3	6LA39841000	SPL-GLASS-ADF		21/P								
4	6LA39866000	STAY-TP-RGT-SCAN		11/P								
5	44202810000	CUSH-GLASS		45/P								
7	6LA86439000	BRKT-TRY-RGT		11/P								
50	6LA08908000	S/TPS/HEX-3*6-NI		410/P								
51	6LA08913000	S/TPS/HEX-4*8-NI		510/P								

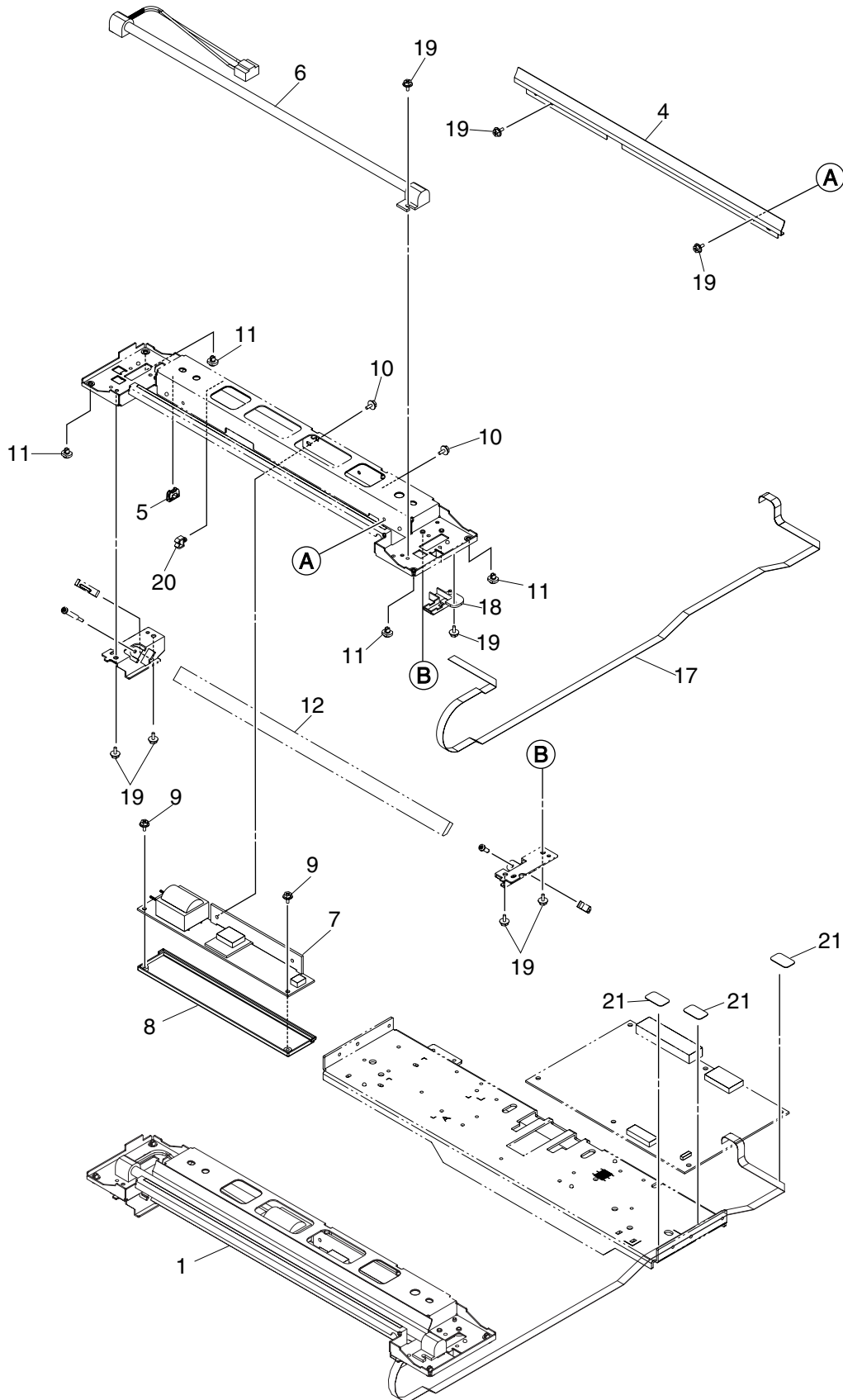

ITEM NO.	PARTS NO.	PARTS NAME	Q'TY / PAGE	Q'TY / PACK	P	I	R	B S I NO.	T O	T	F R O M	S E R I A L NO.	R E M A R K S	C
1	6LA85761000	CARRIGE-1-371		1/1/S										
4	6LA39553000	REFLECTOR-LAMP		1/1/D										
5	F0-00339000	EHP-6U		1/5/P										
6	6LA70819000	LAMP-EXPO-360		1/1/S										
7	6LA70820000	INV-EXPO-360		1/1/C										
8	6LA39548000	COVER-INV		1/1/P										
9	6LA08916000	S/TPP/HEX-3X6-NI		2/10/P										
10	6LA08900000	S/HEX-M3*6-NI		2/10/P										
11	4408604590	FOOT-CRG-3.64		4/5/P										
17	6LA71382000	HRNS-INV-360		1/1/C										
18	6LA39572000	GUIDE-HRNS-CRG1		1/1/P										
19	6LA08908000	S/TPS/HEX-3*6-NI		8/10/P										
20	F0-00044000	UAMS-05-2		1/5/P										
21	6LA39577000	MYLAR-HRNS-INV		3/1/KP										

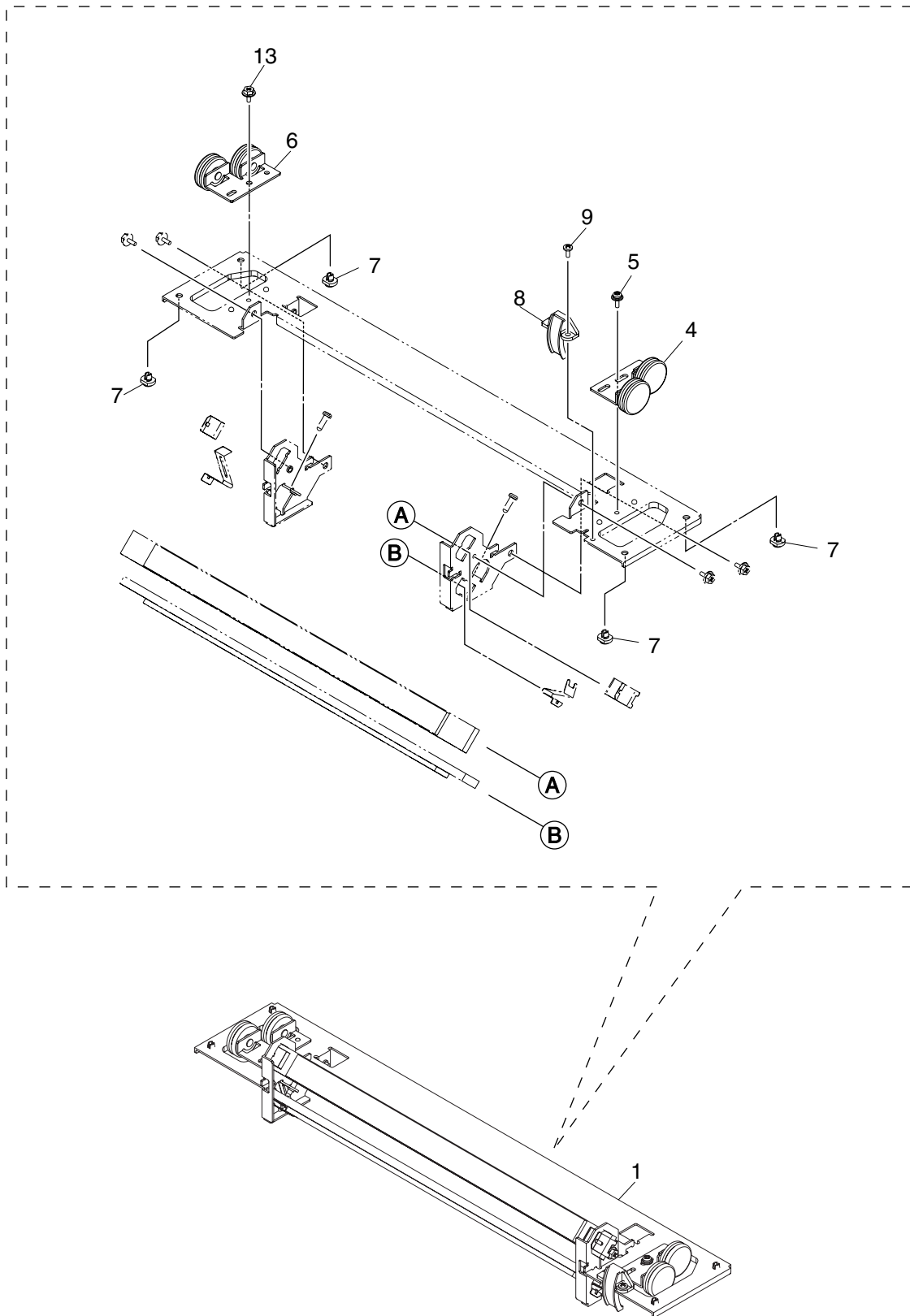

ITEM NO.	PARTS NO.	PARTS NAME	Q'TY / PAGE	Q'TY / PACK	P	I	R	B S I NO.	T O	T	F R O M	S E R I A L NO.	R E M A R K S	C
1	6LA85762000	CARRIGE-2-371		1/1/S										
4	6LA67394000	ASYS-BKT-PLY-F-C2		1/1/P										
5	X0-00077000	S/PAN/SWWP-M3X8-NI		1/10/P										
6	6LA67395000	ASYS-BKT-PLY-R-C2		1/1/D										
7	4408604590	FOOT-CRG-3.64		4/5/P										
8	44202692000	GUIDE-WH-CRG2		1/1/P										
9	X0-02069000	S/TPS/BID-3X6-ZU3		1/10/P										

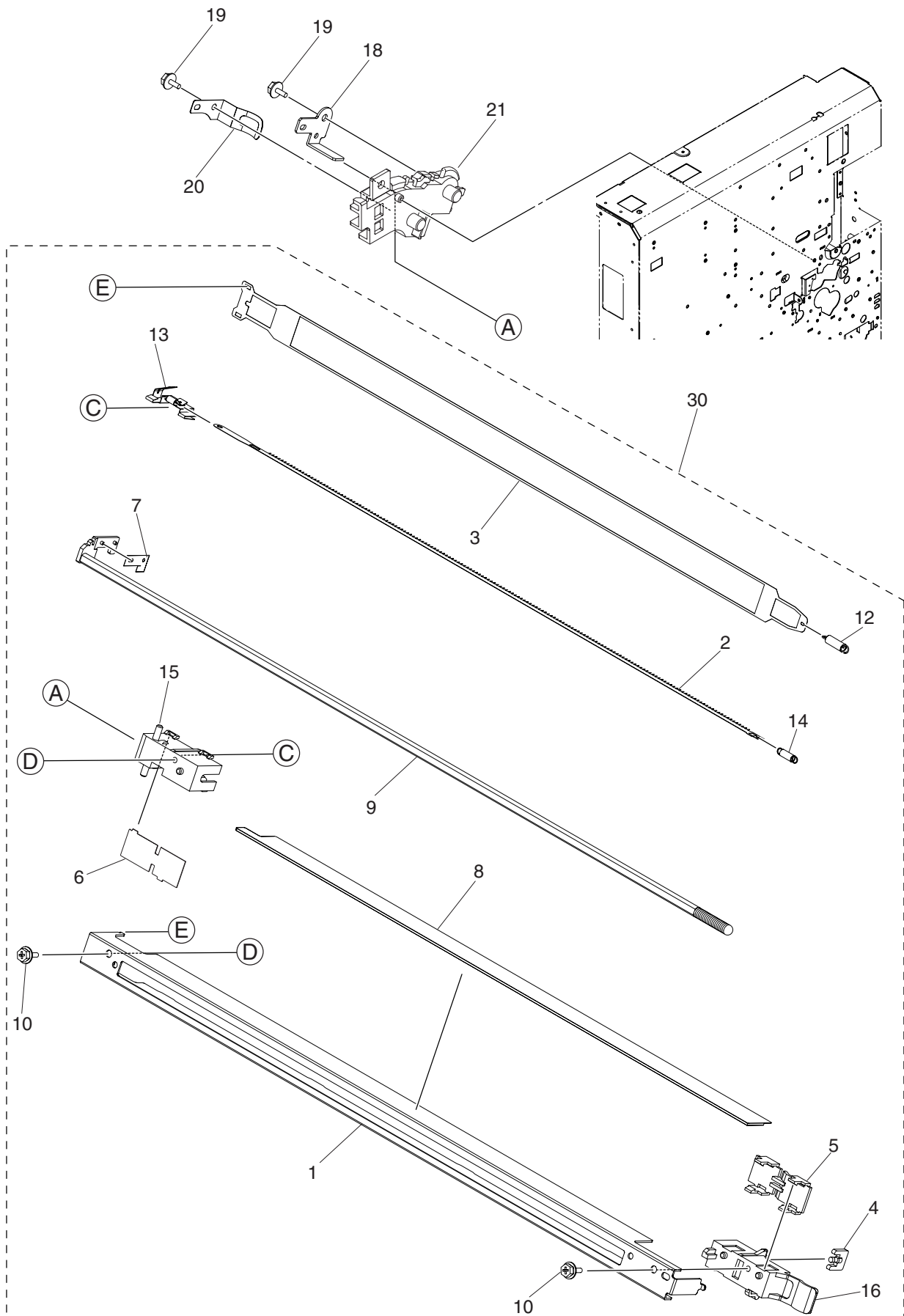

ITEM NO.	PARTS NO.	PARTS NAME	Q'TY / PAGE	Q'TY / PACK	P I R	B S I NO.	T O	T	F R O M	S E R I A L NO.	R E M A R K S	C
1	6LA84920000	CASE-CH-M		1/1/P								
2	6LA84925000	CH-M		1/1/KP								MSP
3	6LA84930000	GRID-CH-M-371		1/1/KP								MSP
4	4401764730	HANGER-WIRE-TR		1/1/P								
5	6LA84944000	LID-CH-M-F		1/1/P								
6	6LA84947000	LID-CH-M-R		1/1/P								
7	6LA84941000	MYLAR-CLN-CH		1/5/P								
8	6LA84957000	MYLAR-LED		1/1/KP								
9	6LA84938000	ROD-CLN-CH-M		1/1/KP								
10	6LA08917000	S/TPP/HEX-3*8-NI		2/10/P								
12	6LA84950000	SPE-GR		1/5/P								
13	6LA84922000	SPL-CH-M-R		1/1/P								
14	6LA84935000	SPRING-TENS-CH		1/5/P								
15	6LA84915000	TERM-CH-M-R		1/1/P								
16	6LA84910000	TERM-CH-M-F		1/1/P								
17	6LA89435000	HRNS-HVT-MG-371		1/1/P								
18	6LA85009000	SPL-CH-M		1/1/P								
19	6LA08916000	S/TPP/HEX-3X6-NI		2/10/P								
20	6LA85008000	SPL-GRID		1/1/P								
21	6LA85005000	TERM-HVT-M		1/1/P								

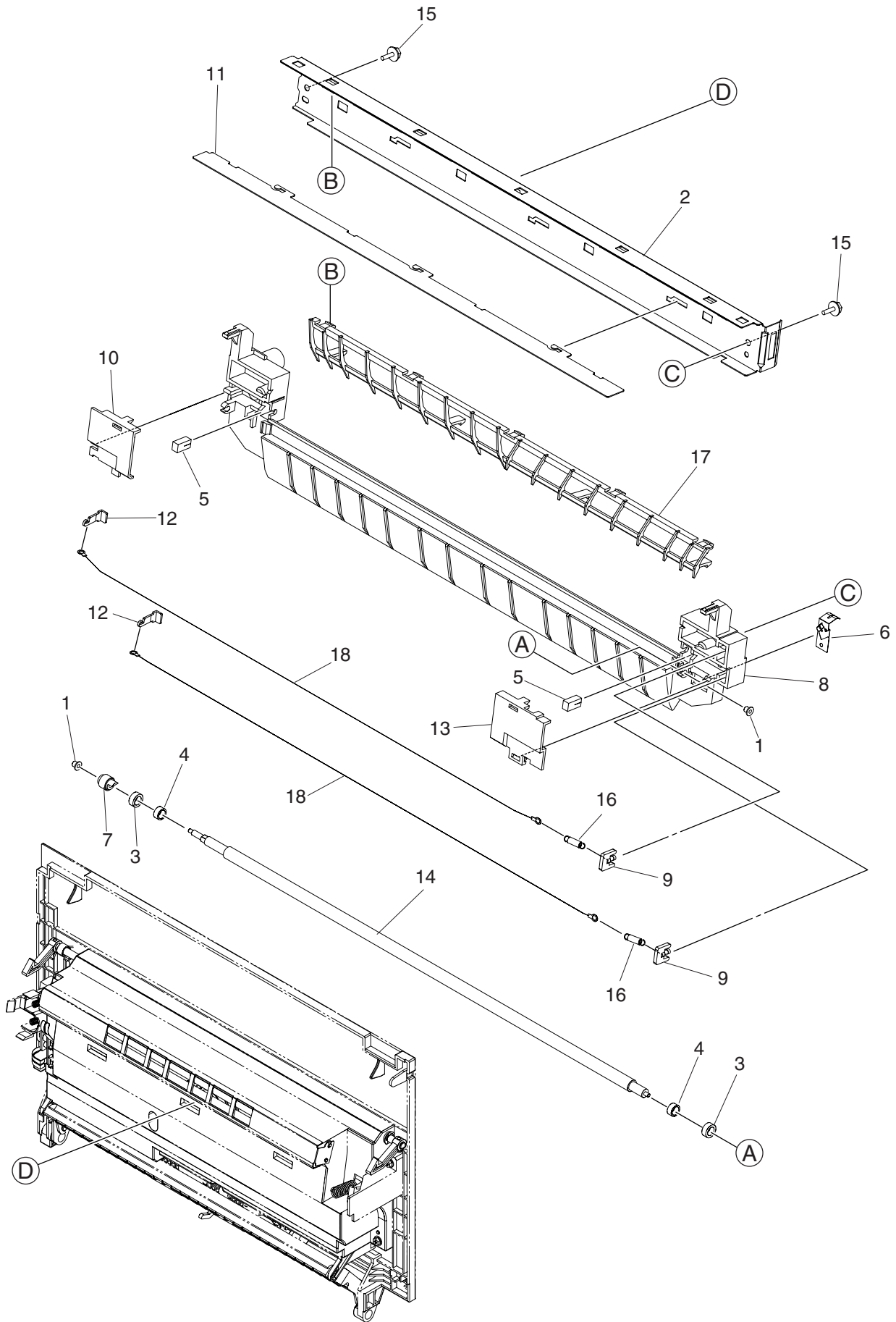

ITEM NO.	PARTS NO.	PARTS NAME	Q'TY / PAGE	Q'TY / PACK	PIR	BSI NO.	TO	T	FROM	SERIAL NO.	REMARKS	C
1	41306677000	BUSH-RLR-GUIDE		21/P								MSP
2	6LA88230000	CASE-CH-TR		11/P								
3	41306323000	COLLER-DRUM		25/P								
4	41306301000	COLLER-RLR-GUID		25/P								
5	41306712000	DAMPER		25/P								
6	6LA88304000	EARTH-CH-TR		11/P								
7	41306272000	GEAR-RLR-GUIDE		11/P								MSP
8	6LA88234000	GUIDE-CH-TR		11/P								
9	4401764730	HANGER-WIRE-TR		21/P								
10	6LA88245000	LID-CH-TR-R		11/P								
11	6LA88238000	PLT-CH-TR		11/KP								
12	44203860000	PLT-TERM-1		21/P								
13	6LA88244000	LID-CH-TR-F		11/P								
14	41306530000	ROLLER-GUIDE		11/KP								MSP
15	6LA08917000	S/TPP/HEX-3*8-NI		210/P								
16	6LA84935000	SPRING-TENS-CH		25/P								
17	6LA88248000	SUPPORTER-371		11/KP								
18	6LA88250000	WIRE-CH-060-353-R		21/P								MSP

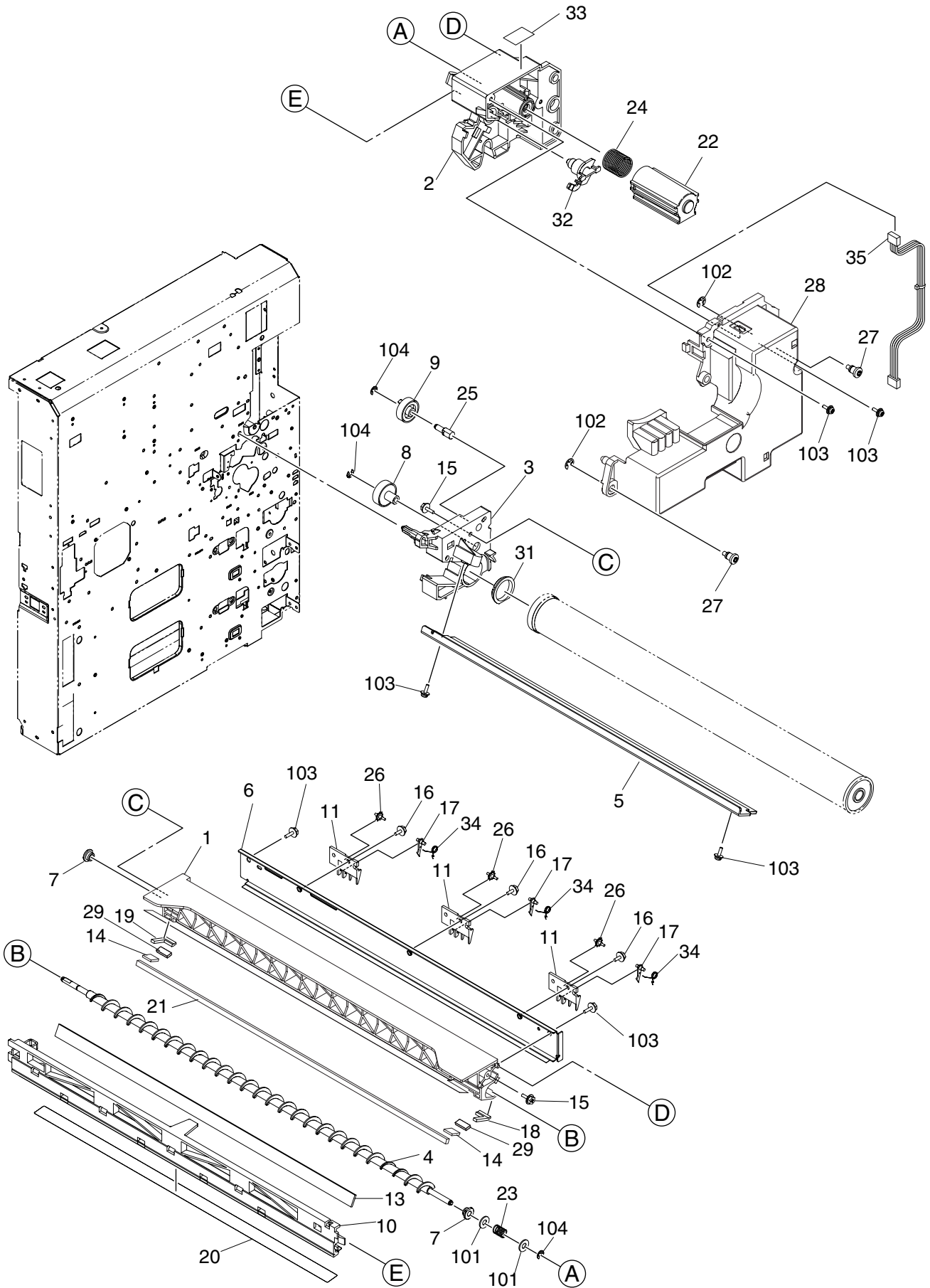

ITEM NO.	PARTS NO.	PARTS NAME	Q'TY / PAGE	Q'TY / PACK	PIR	BSI NO.	TO	T	FROM	SERIAL NO.	REMARKS	C
1	6LA79525000	ASYS-FRAME-CLN-C		1/1/PP								
2	6LA79540000	ASYS-FRAME-CLN-F		1/1/P								
3	6LA79583000	FRAME-CLN-R		1/1/P								
4	6LA79600000	AUGER-CLN		1/1/P								
5	6LA27845000	BL-2320D		1/1/S								CSP
6	6LA79503000	ASYS-BLADE-REC		1/1/KP								MSP
7	6LA02920000	BUSH-0410-05F-M		2/5/P								
8	6LA79605000	GEAR-10S18-4		1/1/P								
9	6LA79606000	GEAR-10S17-4		1/1/P								
10	6LA79626000	HLDR-LED		1/1/P								
11	6LA79615000	HOLDER-SCRAPER		3/1/P								
13	6LA89106000	PWA-F-DLE-371		1/1/SB								
14	6LA79547000	SEAL-BLADE-SIDE		2/5/KP								
15	6LA08917000	S/TPP/HEX-3*8-NI		2/10/P								
16	6LA08900000	S/HEX-M3*6-NI		3/10/P								
17	6LA79618000	SCRAPER-371		3/3/P								MSP
18	6LA79546000	SEAL-CLN-F		1/5/P								
19	6LA79586000	SEAL-CLN-R		1/5/P								
20	6LA79628000	MYLAR-HLDR-LED		1/1/KP								
21	6LA79531000	SEAL-CLN-C		1/5/KP								
22	6LA79609000	SHUTTER-CLN		1/1/P								
23	6LA79602000	SPC-AUGER		1/5/P								
24	6LA79612000	SPC-NZL-CLN		1/1/P								
25	6LA79554000	STUD-GEAR-CLN		1/1/P								
26	41306325000	WHEEL-CLN-8		3/1/P								
27	6LA65682000	SCREW-CLNR-DEV		2/10/P								
28A	6LA79653100	COV-PU-F-U		1/1/PP							NAD	
28B	6LA79653200	COV-PU-F-E		1/1/PP							MJD, TWD	
28C	6LA79653300	COV-PU-F-D		1/1/PP							ASD, AUD, CN D	
29	6LA79534000	SEAL-SIDE-REC		2/5/KP								
31	41306135000	BUSH-1821*03-M		1/1/P								
32	6LA79622000	PIN-DRUM-371		1/1/P								
33	6LA91423000	LBL-HNDL-CLNR		1/5/P								
34	41305536000	SPD-SCRPR-DRUM		3/1/P								
35	6LA89453000	HRNS-DLE2-371		1/1/P								
101	X0-00936000	W/PL/PJO-4-ZC		2/10/P								
102	X0-00965000	RR/E-4-SS		2/10/P								
103	6LA80090000	S/TPP/BID-3*8-NI		6/5/P								
104	X0-00974000	RR/E-2.5-SS		3/10/P								

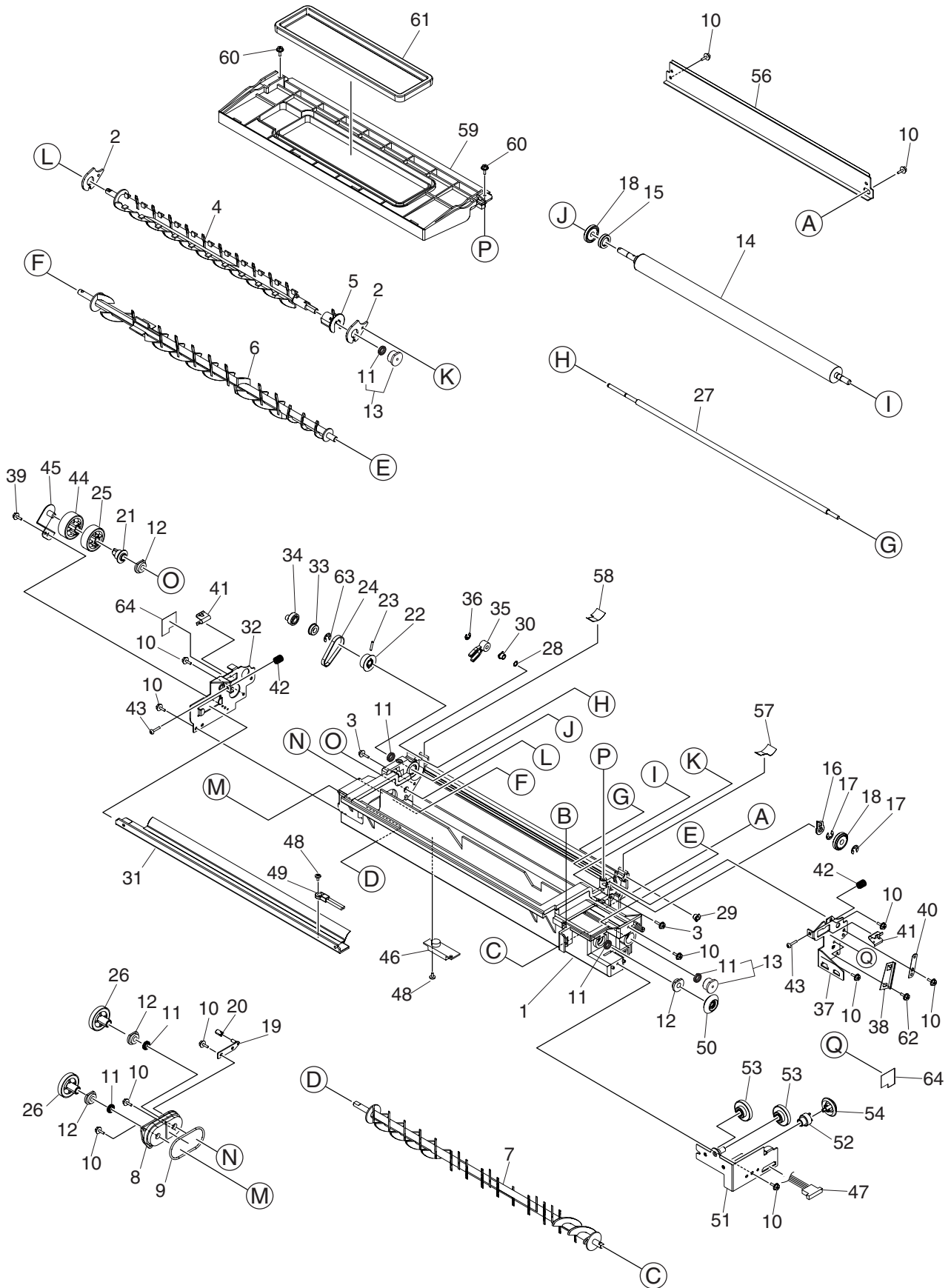

ITEM NO.	PARTS NO.	PARTS NAME	Q'TY / PAGE	Q'TY / PACK	P I R	B S I NO.	T O	T	F R O M	S E R I A L NO.	R E M A R K S	C
1	6LA81612000	ASYS-CASING-DEV		11/C								
2	6LA81632000	PLATE-SIDE		21/P								
3	6LA08902000	S/HEX-M3*10-NI		210/P								
4	6LA81635000	MIXER-1-371		11/P								
5	6LA81636000	SPACER-MIX		11/P								
6	6LA81639000	ASYS-MIXER-2		11/P								
7	6LA81643000	MIXER-3-371		11/P								
8	6LA81654000	BUSH-DEV-R		11/P								
9	6LA81630000	SEAL-BUSH-R		11/P								
10	6LA08917000	S/TPP/HEX-3*8-NI		1310/P								
11	4401949290	SEAL-VC6-10-2.5		61/P								
12	4407728150	BUSH-6-GCB		45/P								
13	6LA81645000	ASYS-BUSH-0613-07		21/P								
14	6LA81650000	ROLLER-MG-371		11/KP								
15	4401950220	V-RING-MG-210		11/P								
16	6LA81652000	BUSH-DEV		15/P								
17	X0-00965000	RR/E-4-SS		210/P								
18	6LA81662000	ROLL-GUIDE-371		21/P								
19	6LA81678000	ASYS-BKT-DEV-TENS		11/P								
20	4401950980	COLLAR-DEV-TENS		15/P								
21	6LA81670000	PULLY-2GT16-6		11/P								
22	6LA81666000	PULLY-2GT27-6		11/P								
23	X0-00980000	P/PRL/AH7-2X10-SS		110/P								
24	6LA81674000	BLT/T-2GT-92		11/P								
25	6LA81677000	GEAR-10S27-CUP		11/P								
26	4402439380	GR-10H27-5-06		21/P								
27	6LA81750000	ROLLER-RE		11/P								
28	6LA81755000	WAS-RE-ROL		110/P								
29	6LA81753000	BUSH-RE-ROL-F		11/P								
30	6LA81752000	BUSH-RE-ROL-R		11/P								
31	6LA81656000	ASYS-DOCTOR-371		11/KP								
32	6LA81691000	BRKT-DEV-R-371		11/P								
33	6LA81664000	BRG-LF126ZZLY13		11/P								
34	6LA81769000	CAM-RE-ROL		11/P								
35	6LA81773000	ONEWAY-DRV-RE		11/P								
36	X0-00974000	RR/E-2.5-SS		110/P								
37	6LA81711000	BRKT-DEV-F-371		11/P								
38	6LA81718000	ADJUSTER-MG		11/P								
39	6LA08909000	S/TPS/HEX-3*8-NI		110/P								
40	6LA81758000	SPL-BIAS-RE-ROL		11/P								
41	4401949700	SPL025-S631-DC2		21/P								
42	4400672520	SPC060-065-0130		21/P								
43	4400672800	SCREW-DOCTOR		210/P								
44	6LA81724000	GEAR-10S28-6		11/P								
45	6LA81729000	ASYS-BRKT-DRV		11/P								
46	4402859550	SNR-ATC-121		11/D								
47	6LA89424000	HRNS-ATS-371		11/P								
48	X0-01725000	S/BID-M3X5-BSNI		210/P								
49	6LA89113000	THMS-DRM-371		11/C								
50	6LA81685000	GEAR-10B22-6		11/P								
51	6LA81890000	ASYS-BRKT-RECY		11/P								
52	6LA81888000	GEAR-8S15-6		11/P								
53	6LA81887000	GEAR-8S29-8S15-6		21/P								
54	6LA81881000	GEAR-10B22-6-CUP		11/P								
56	6LA81740000	ASYS-GUIDE-DEV		11/KP								
57	6LA81780000	SHEET-MG-F		15/P								
58	6LA81781000	SHEET-MG-R		15/P								
59	6LA81790000	ASYS-COV-DEV		11/C								
60	6LA08901000	S/HEX-M3*8-NI		210/P								
61	4400915220	COV-DEV-BTL		11/P								
62	X0-00077000	S/PAN/SWWP-M3X8-NI		110/P								
63	X0-00966000	RR/E-5-SS		110/P								
64	6LA81714000	MYLAR-DOC-SLIDE		25/P								

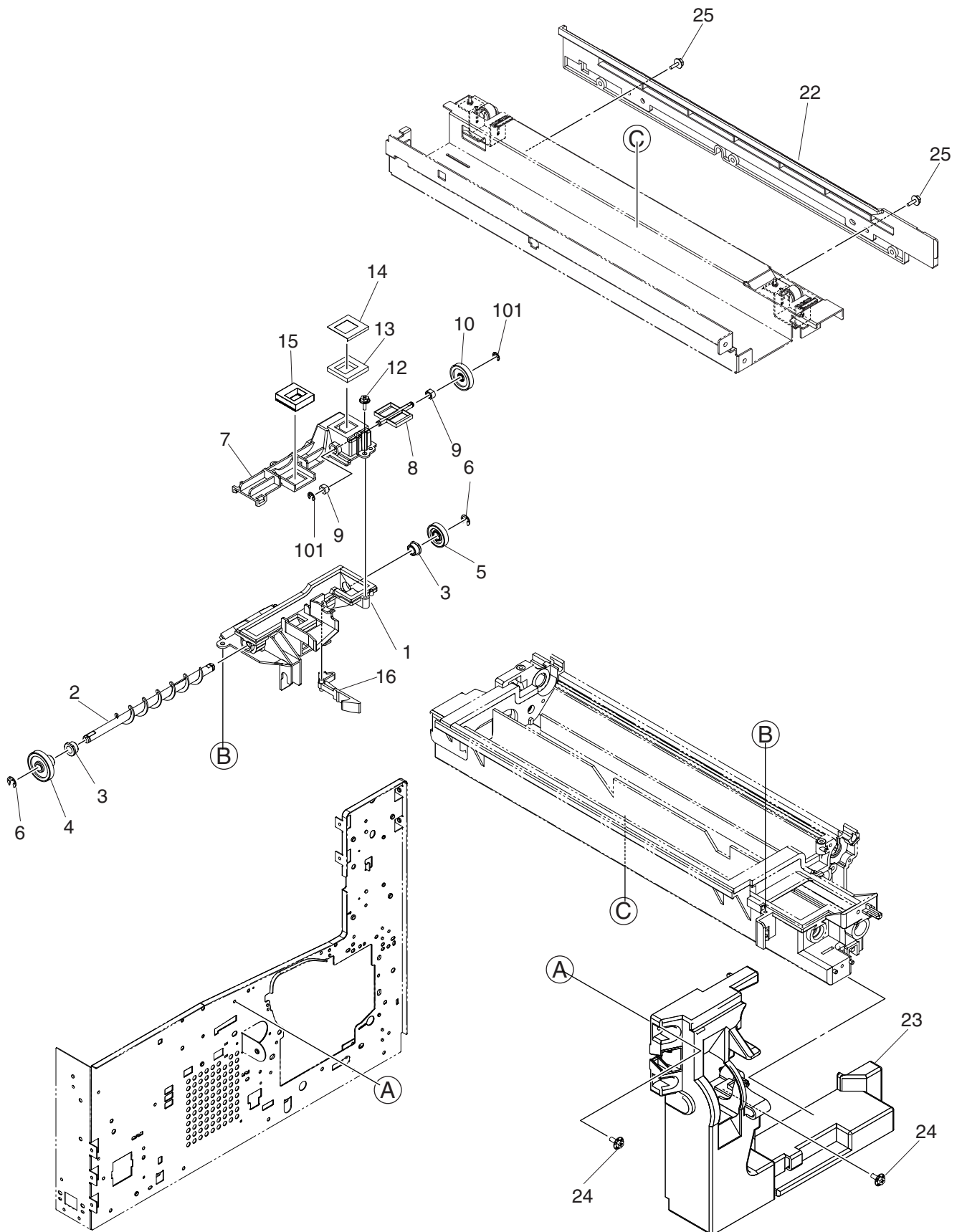

ITEM NO.	PARTS NO.	PARTS NAME	Q'TY / PAGE	Q'TY / PACK	P I R	B S I NO.	T O	T	F R O M	S E R I A L NO.	R E M A R K S	C
1	6LA81695000	ASYS-COV-NOZLE		1/1/PP								
2	6LA81922000	AUGER-RECY-F371		1/1/P								
3	6LA81925000	BUSH-0611-06F-M		2/5/P								
4	6LA81936000	GEAR-8S22-6		1/1/P								
5	6LA81935000	GEAR-8S29-6		1/1/P								
6	X0-00965000	RR/E-4-SS		2/10/P								
7	6LA81932000	COVER-RECYCLE		1/1/PP								
8	6LA81942000	PADDLE-RECY		1/1/P								
9	6LA81928000	BUSH-PADDLE		2/5/P								
10	6LA81937000	GEAR-8S25-4		1/1/P								
12	6LA08917000	S/TPP/HEX-3*8-NI		1/10/P								
13	6LA81953000	SEAL-RECY-CLN		1/1/P								
14	6LA81952000	MYLAR-RECY-CLN		1/1/P								
15	6LA81955000	ASYS-TNR-IN		1/1/P								
16	6LA81707000	STOPPER-LID-371		1/1/P								
22	6LA85881000	ASYS-STAY-DEV-R-RGST		1/1/P								
23	6LA82050000	COV-INNER-F371		1/1/P								
24	6LA08913000	S/TPS/HEX-4*8-NI		2/10/P								
25	6LA08909000	S/TPS/HEX-3*8-NI		2/10/P								
101	X0-00974000	RR/E-2.5-SS		2/10/P								

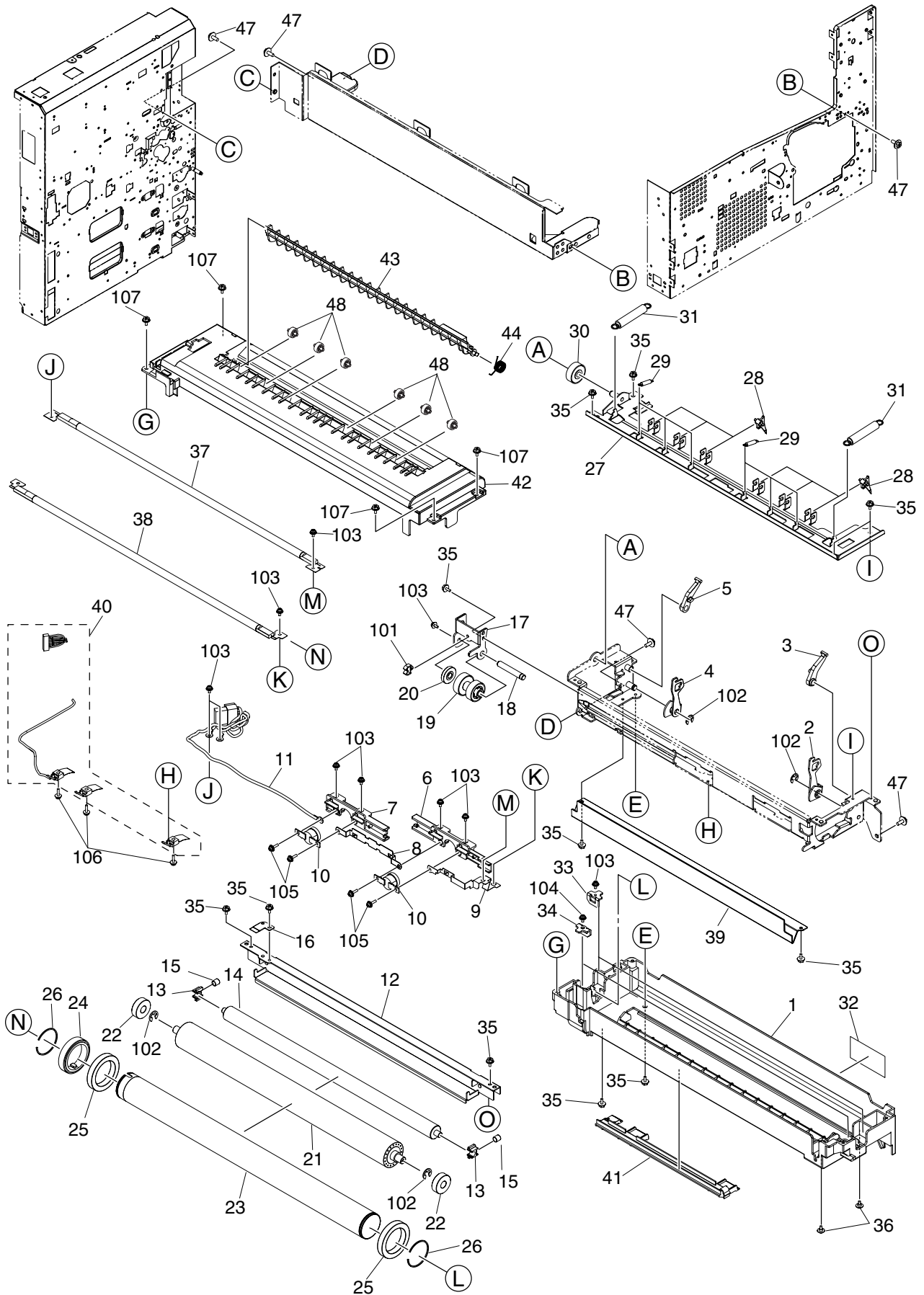

ITEM NO.	PARTS NO.	PARTS NAME	Q'TY / PAGE	Q'TY / PACK	PIR	BSI NO.	TO	T	FROM	SERIAL NO.	REMARKS	C
1	6LA84153000	COVER-FUSER-L-371		11/PP								
2	6LA84072000	ARM-PR-F		11/P								
3	6LA84163000	LVR-P-REL-F		11/P								
4	6LA84073000	ARM-PR-R		11/P								
5	6LA84164000	LVR-P-REL-R		11/P								
6	6LA84177000	ASYS-HOLDER-THMS-371		11/PP								
7	6LA84179000	ASYS-HOLDER-THMS-C-371		11/P								
8	6LA84083000	PLT-THMS-CNT		11/P								
9	6LA84084000	PLT-THMS-LMP		11/P								
10	6LA89107000	THRMST-HTR-371		21/C								
11	6LA89443000	HRNS-LP-ACIN2-371		11/P								
12	6LA84052000	STAY-ROL-CLN		11/P								
13	6LA84131000	BUSH-CLN-PRS-371		21/P								
14	6LA27848000	B-2320-L		11/S								CSP
15	6LA84134000	SPC-CR-FUS		25/P								
16	41306533000	BRUSH-FUSER-P		11/KP								
17	6LA84078000	BRKT-G-ENT-FUS		11/P								
18	6LA84043000	STUD-G-IN-FUSER		11/P								
19	6LA84140000	GEAR-10H21-10S20-6-FUS		11/P								
20	6LA84142000	ROL-IDLE-FUS-371		11/P								
21	6LA27847000	HR-2320-L		11/S								CSP
22	44202925000	BRG608ZZM4		21/P								
23	6LA27846000	HR-2320-U		11/S								CSP
24	6LA84182000	GEAR-HR-RLR		11/P								
25	6LA84106000	BRG6806ZZ-HR		21/P								
26	41305515000	CRR-HT/RLR		25/P								
27	6LA84063000	ASYS-STAY-SCPR		11/P								
28	6LA84095000	SCRAPER-HR-371		66/P								MSP
29	6LA84096000	SPE-SCR-HR-371		61/P								
30	41306061000	GEAR-HR/EXIT		11/P								
31	6LA84111000	SPE-PR-371		21/P								
32	6LA91430000	LBL-HOT		11/KP								
33	6LA84080000	PLT-TERM-M3		21/P								
34	6LA84081000	PLT-TERM-M4		21/P								
35	6LA08908000	S/TPS/HEX-3*6-NI		1210/P								
36	41306916000	SCREW-SPEAKER		210/P								
37A	6LA84100100	LAMP-HTR-C-371-NAD		11/C							NAD	
37B	6LA84100200	LAMP-HTR-C-371-MJD		11/C							MJD,ASD,AU D,CND,TWD	
38A	6LA84101100	LAMP-HTR-S-371-NAD		11/C							NAD	
38B	6LA84101200	LAMP-HTR-S-371-MJD		11/C							MJD,ASD,AU D,CND,TWD	
39	6LA84157000	GUIDE-ENT-FUS-371		11/P								
40	6LA89105000	THMS-HTR-371		11/C								
41	6LA84167000	COVER-WH-THMS		11/KP								
42	6LA84155000	COVER-FUSER-U-371		11/P								
43	6LA84160000	GUIDE-OP-FUS-371		11/P								
44	6LA84136000	SPA-G-OP-FUS-371		11/P								
47	6LA08913000	S/TPS/HEX-4*8-NI		510/P								
48	6LA82550000	ROLL-GUIDE-EXIT		61/P								
101	F0-00043000	UAMS-05SN-W		15/P								
102	X0-00966000	RR/E-5-SS		410/P								
103	X0-00060000	S/PAN/SWWP-M3X6-NI		710/P								
104	X0-00164000	S/PAN/SWWP-M4X8-NI		210/P								
105	X0-00094000	S/PAN/SWWP-M3X10-NI		410/P								
106	X0-00434000	S/BID-M3X8-NI		310/P								
107	6LA80090000	S/TPP/BID-3*8-NI		45/P								

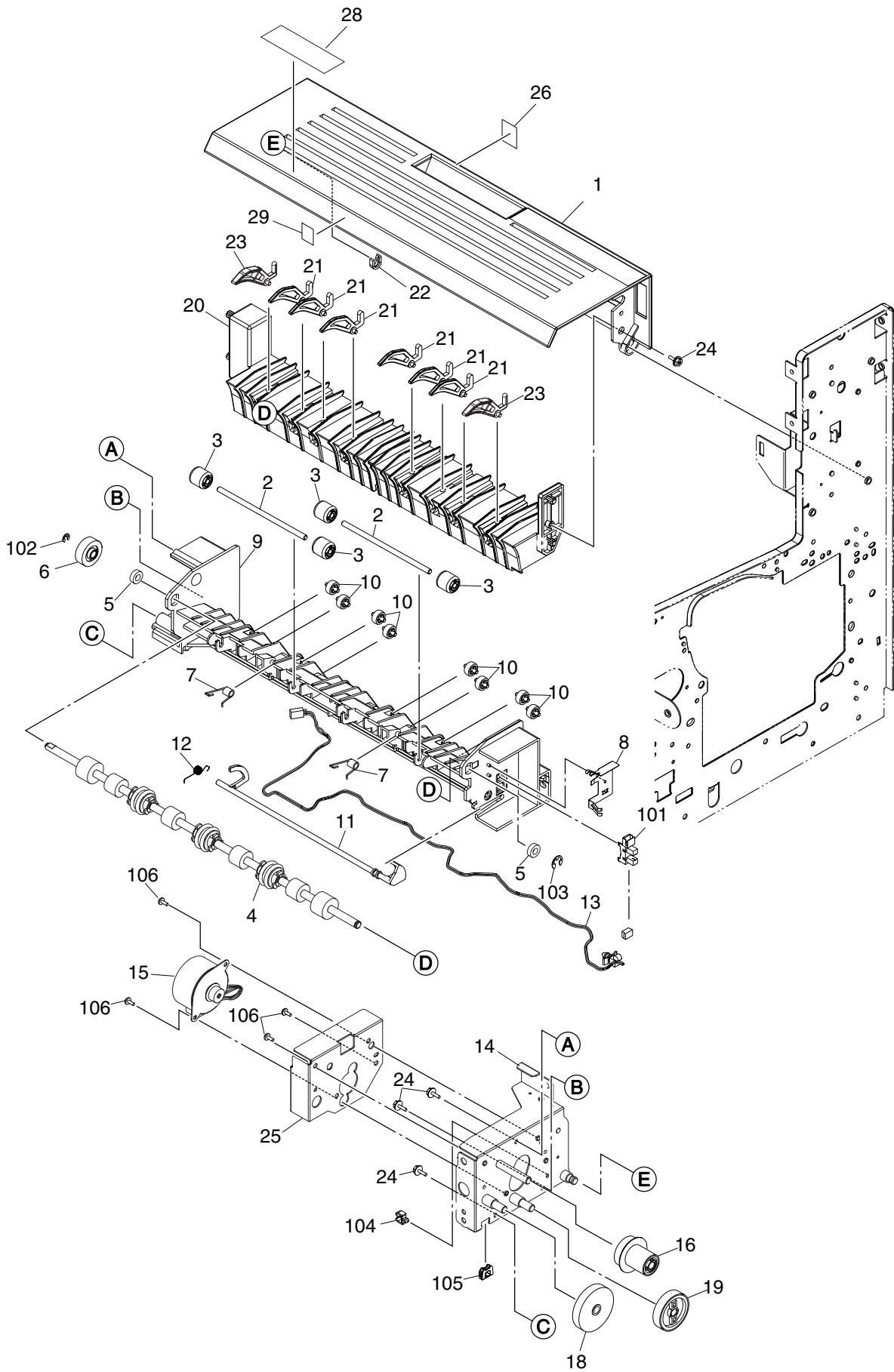

ITEM NO.	PARTS NO.	PARTS NAME	Q'TY / PAGE	Q'TY / PACK	P I R	B S I NO.	T O	T	F R O M	S E R I A L NO.	R E M A R K S	C
1	6LA82718000	COVER-EXIT-371		1/1/PP								
2	6LA82554000	SFT-EXIT-IDLE		2/1/P								
3	44203198000	ROLL-EXIT-L-320		4/1/P								
4	6LA82582000	ASYS-RLR-EXIT-371		1/1/KP								
5	6LA30795000	DDL-1260ZZH-POP25LY13		2/1/P								
6	44202975000	GEAR-EXIT-U		1/1/P								
7	6LA82563000	SPG-T-EXIT-371		2/1/P								
8	6LA82599000	SPG-F-EARTH-EXIT-371		1/1/P								
9	6LA82546000	GUIDE-EXIT-L-371		1/1/PP								
10	6LA82550000	ROLL-GUIDE-EXIT		8/1/P								
11	6LA82558000	ACT-EXIT-371		1/1/D								
12	6LA82561000	SPG-T-ACT-EXIT		1/1/P								
13	6LA89425000	HRNS-EXIT-371		1/1/P								
14	6LA82622000	ASYS-BKT-EXIT-371		1/1/P								
15	6LA82692000	ASYS-MOTR-S-EXIT-371		1/1/C								
16	6LA82652000	GEAR-10S16-PS2M40-6		1/1/P								
17	6LA78447000	BLT-SY-S2M-120-4		1/1/P								
18	41306160000	GEAR-DRV-EXIT-7		1/1/P								
19	41306303000	GEAR-EXIT-9		1/1/P								
20	6LA82761000	ASYS-GUIDE-EXIT-U-371		1/1/PP								
21	6LA82742000	GATE-EXIT		6/1/P								
22	4407972860	STOP-RING-6-5		1/5/P								
23	6LA82502000	GATE-EXIT-B		2/1/P								
24	6LA08917000	S/TPP/HEX-3*8-NI		4/10/P								
25	6LA82503000	HS-MOTR-EXIT		1/1/P								
26	6LA91349000	LBL-JAM-2		1/5/P								
28	6LA75470000	LBL-HOT-COV		1/1/KP								
29	41307995000	LBL/W-FUSER		1/5/KP								
101	4401983230	SZ-LG248L1		1/1/P								
102	X0-00964000	RR/E-3-SS		1/10/P								
103	X0-00965000	RR/E-4-SS		1/10/P								
104	F0-00044000	UAMS-05-2		1/5/P								
105	F0-00339000	EHP-6U		1/5/P								
106	X0-00676000	S/TPS/BID-3X6-NI		4/10/P								

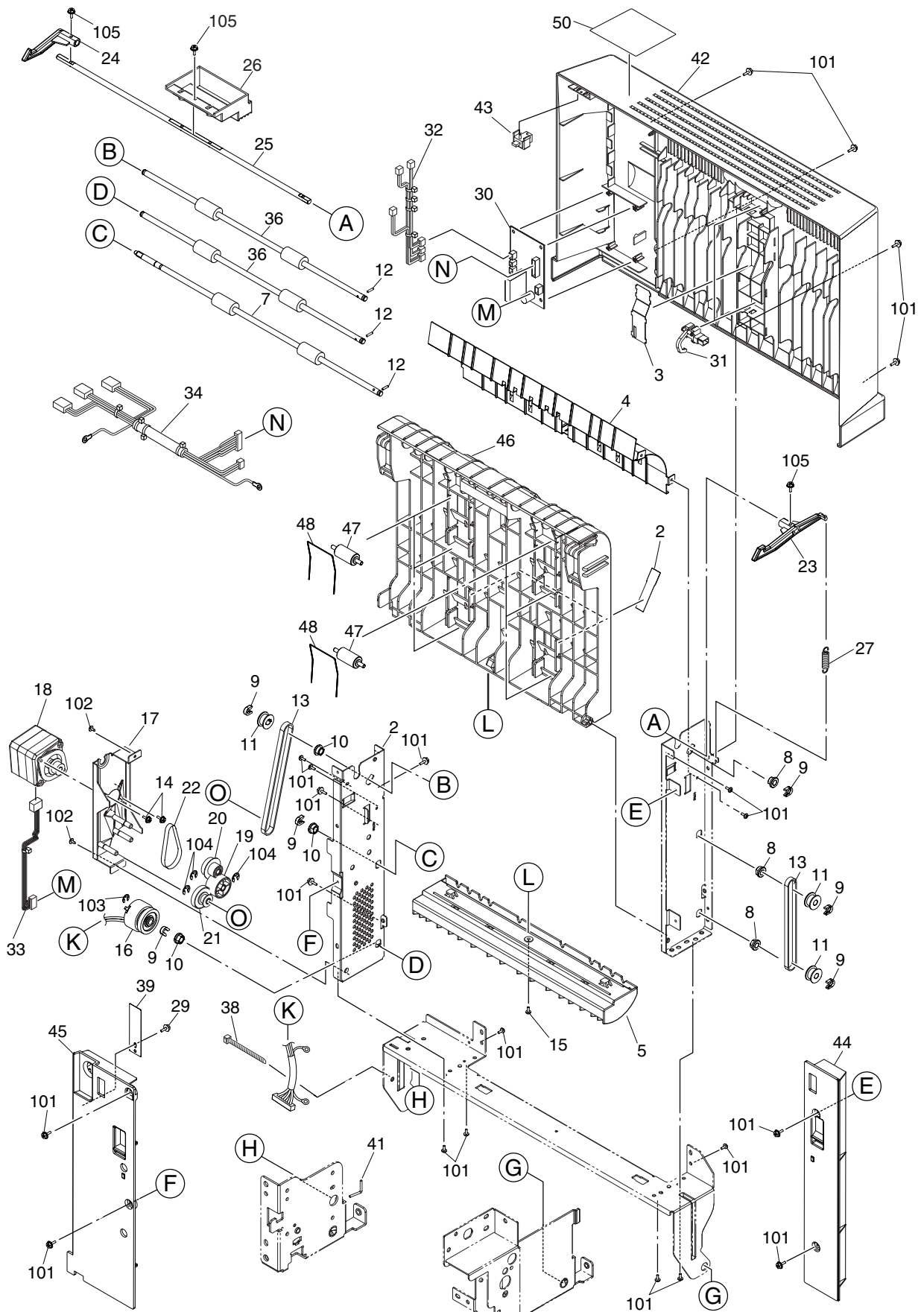

ITEM NO.	PARTS NO.	PARTS NAME	Q'TY / PAGE	Q'TY / PACK	P I R	B S I NO.	T O	T	F R O M	S E R I A L NO.	R E M A R K S	C
1	6LA78792000	GUIDE-ADU-BYP-L-371		1/1/PP								
2	6LA78721000	MYLAR-TRNS-ADU		2/1/P								
3	6LA78717000	MYLAR-COV-ADU-371		1/1/KP								
4	6LA78682000	GUIDE-PAPER-UPR-371		1/1/D								
5	6LA78797000	GUIDE-ADU-BYP-U-371		1/1/PP								
7	6LA78672000	ROLL-TRANS-C-371		1/1/KP								
8	4407734980	BUSH-6-GCB		3/5/P								
9	4407972860	STOP-RING-6-5		6/5/P								
10	44201492000	BUSH-6-POM		3/5/P								
11	41317051000	PLY/T-2GT020-6F		3/1/P								
12	X0-00979000	P/PRL/AH7-2X8-SS		3/10/P								
13	6LA78706000	BLT/T-258-2GT-5		2/1/P								
14	6LA08908000	S/TPS/HEX-3*6-NI		2/10/P								
15	6LA08900000	S/HEX-M3*6-NI		2/10/P								
16	6LA78512000	CLUTCH-G28-06D-35E		1/1/D								
17	6LA78752000	ASYS-BKT-MOT-ADU-371		1/1/P								
18	6LA78482000	AYSY-MOTR-S-ADU-371		1/1/C								
19	6LA78452000	GEAR-10S28-P2GT20-6		1/1/P								
20	6LA78772000	GEAR-10S15-PS2M39-6		1/1/P								
21	6LA78496000	GEAR-10S28-06		1/1/P								
22	6LA78447000	BLT-SY-S2M-120-4		1/1/P								
23	41316054000	LEVER-LATCH-F		1/1/P								
24	44203255000	LEVER-LATCH-R32		1/1/P								
25	6LA78701000	SFT-OPEN-371		1/1/P								
26	6LA78697000	LEVER-OPEN-ADU-371		1/1/P								
27	41316064000	SPE-068-070-241		1/1/P								
29	6LA08917000	S/TPP/HEX-3*8-NI		1/10/P								
30	6LA88704000	PWA-F-ADU-371		1/1/SB								
31	4401983080	SZ-FED-210		2/1/P								
32	6LA89462000	ASY-HRNS-ADU-SNR-371		1/1/P								
33	6LA89448000	HRNS-ADU-MOT-371		1/1/P								
34	6LA89431000	HRNS-ADU-371		1/1/P								
36	6LA78662000	ROLL-TRANS-UL-371		2/1/KP								
38	F0-00455000	SKB-1M		1/5/P								
39	44203240000	SPL-ADU-320		1/1/P								
41	6LA60573000	PIN-COVER-FRT		1/1/P								
42	6LA78782000	CASE-ADU-371		1/1/PP								
43	4402859600	SP-CS3A-B2BA		1/1/D								
44	44203271000	COVER-INSIDE-F		1/1/P								
45	44203272000	COVER-IN-R-320		1/1/P								
46	6LA78732000	GUIDE-PAPER-IN-371		1/1/P								
47	6LA78742000	ROLL-TRANS-IDLE-371		6/1/P								
48	41316103000	SPR-IDLE		6/1/P								
50	6LA28607000	LBL-O-PLACE-COV		1/1/KP								
101	6LA08909000	S/TPS/HEX-3*8-NI		20/10/P								
102	6LA08935000	SCR-M3X6BISR-NI		2/10/P								
103	X0-00965000	RR/E-4-SS		1/10/P								
104	X0-00966000	RR/E-5-SS		3/10/P								
105	6LA08901000	S/HEX-M3*8-NI		3/10/P								

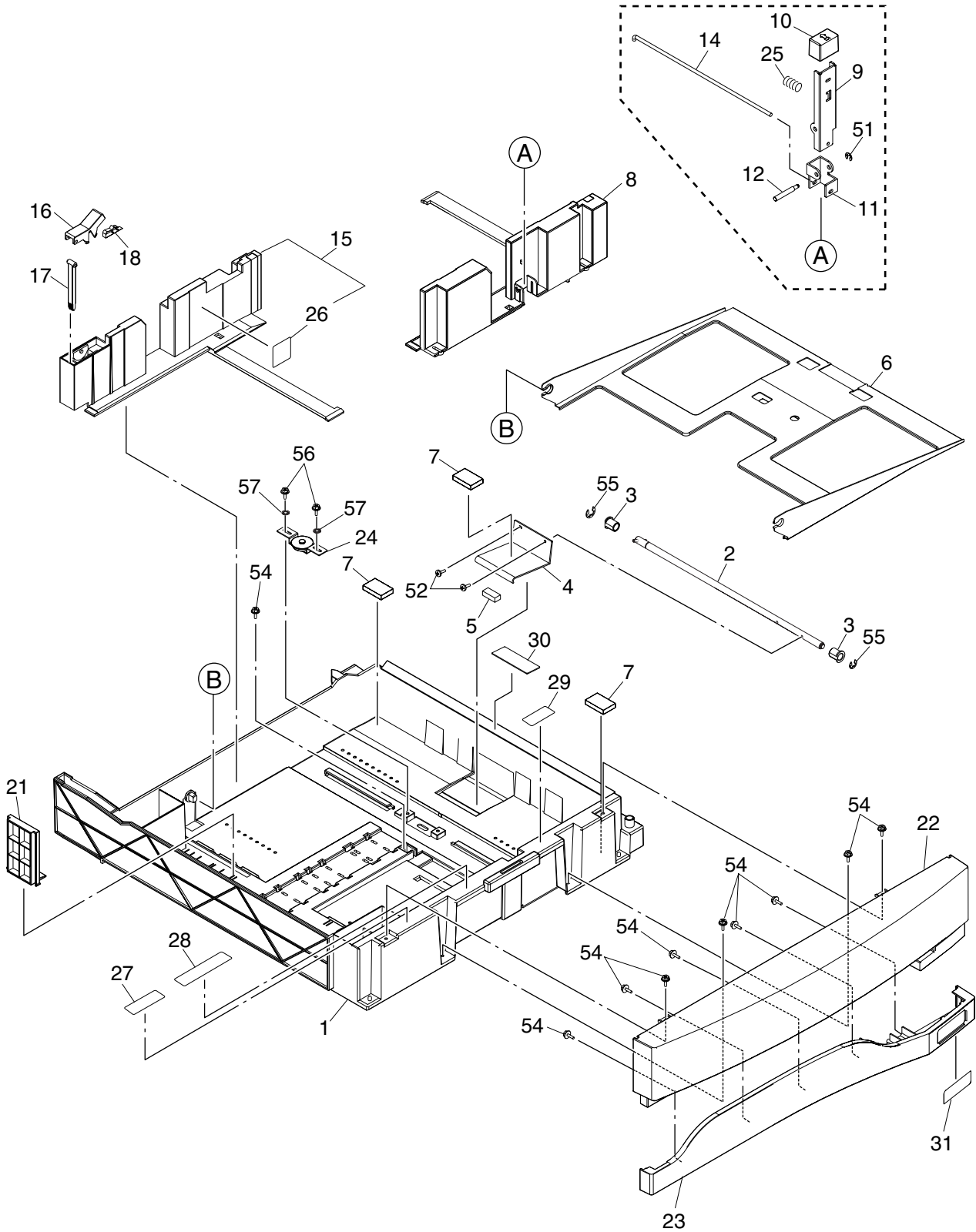

ITEM NO.	PARTS NO.	PARTS NAME	Q'TY / PAGE	Q'TY / PACK	PIR	BSI NO.	TO	T	FROM	SERIAL NO.	REMARKS	C
1	41306032000	CST-AT		1/1/C								
2	41304004000	K-SFT-LIFT-TRAY		1/1/P								
3	41306028000	BUSH-SFT-LIFT		2/5/P								
4	6LA29052000	LEVER-LIFT-TRAY		1/1/P								
5	41306614000	CUSH-LVR-LIFT		1/5/P								
6	6LA29053000	ASYS-TRAY-CST		1/1/P								
7	41306517000	CUSH-TRAY-CST		3/1/P								
8	41306033000	WALL-SIDE-F-AT		1/1/PP								
9	41305015000	LVR-ADJUST-WALL		1/1/P								
10	6LA29056000	LID-LEVER-ADJUST		1/1/P								
11	41305012000	PL-ADJUST-WALL		1/1/P								
12	41304510000	PIN-ADJUST-LVR		1/1/P								
14	41304511000	PIN-ADJUST-WALL		1/1/P								
15	41304065000	K-WALL-SIDE-R		1/1/PP								
16	6LA29058000	LEVER-LOCK-WALL-RER		1/1/P								
17	41306260000	LOCK-WALL-R		1/1/P								
18	41305546000	SPL-LOCK-WALL-R		1/1/P								
21	6LA29061000	WALL-CSSTT-END		1/1/P								
22	6LA60646000	COVER-CSSTT		1/1/PP								
23	6LA60647000	COVER-CSSTT-HNDL		1/1/PP								
24	6LA29059000	ASYS-PLATE-PINION		1/1/P								
25	41305503000	SPC-LVR-WALL		1/1/P								
26	41307701000	LBL/O-P-MAX		1/5/KP								
27	6LA29062000	LBL-O-PAPER		1/1/KP								
28	6LA29063000	LBL-O-GUIDE		1/1/KP								
29	6LA29064000	LBL-O-ID		1/1/KP								
30	41307599000	SHEET-CST		1/1/KP								
31A	6LA29549000	SHEET-SIZE-LT		1/1/KP							NAD	
31B	6LA29550000	SHEET-SIZE-A4		1/1/KP							MJD, ASD, AUD, D, CND, TWD	
51	X0-00963000	RR/E-2-SS		1/10/P								
52	X0-00434000	S/BID-M3X8-NI		2/10/P								
54	6LA08917000	S/TPP/HEX-3*8-NI		10/10/P								
55	X0-00968000	RR/E-7-SS		2/10/P								
56	X0-01989000	S/TPP/BID-3X8-NI		2/10/P								
57	X0-02116000	W/TH/A-3-SS		2/10/P								

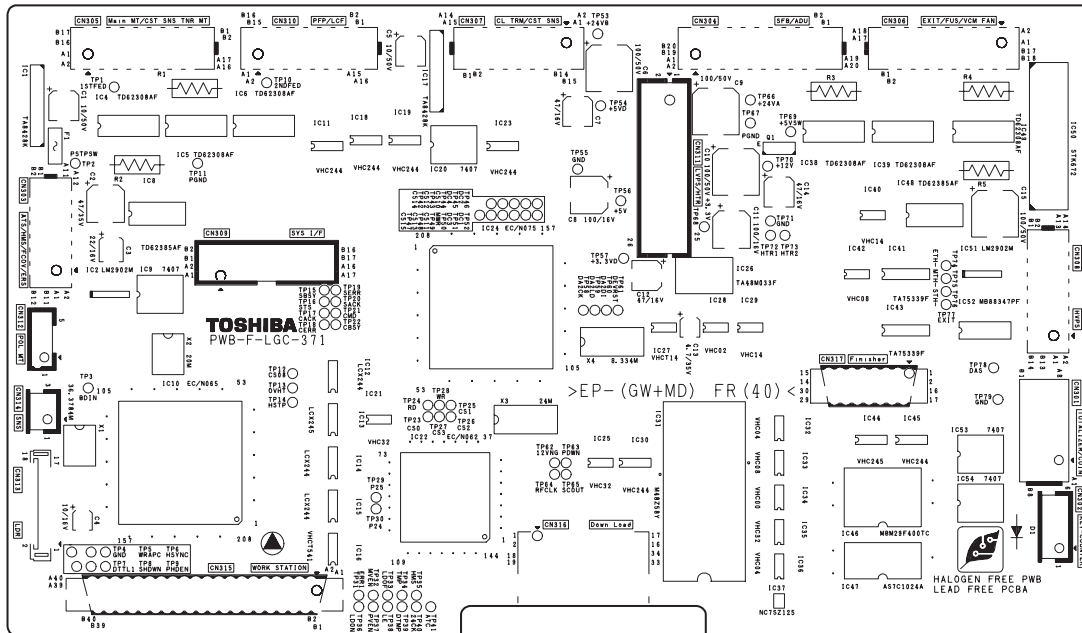

ITEM NO.	PARTS NO.	PARTS NAME	Q'TY / PAGE	Q'TY / PACK	P	I	R	BSI NO.	TO	T	FROM	SERIAL NO.	REMARKS	C
0A	6LA89809000	ASY-PWA-LGC-371S		1/1/SB									e-STUDIO230	
0B	6LA89810000	ASY-PWA-LGC-372S		1/1/SB									e-STUDIO280	
11	C0-00921000	TA8428K(S) IC1		1/5/S										
12	C0-06860001	IC2		1										
14	C0-08141001	IC4		1										
15	C0-08141001	IC5		1										
16	C0-08141001	IC6		1										
18	C0-08142001	IC8		1										
19	C0-01957001	DM7407MX IC9		1/5/S										
20	C0-06993000	IC10		1										
21	C0-01943001	74VHC244MTCX IC11		1/1/S										
22	C0-01931001	74LCX244MTCX IC12		1/1/S										
23	C0-01932001	74LCX245MTCX IC13		1/1/S										
24	C0-01931001	74LCX244MTCX IC14		1/1/S										
25	C0-01931001	74LCX244MTCX IC15		1/1/S										
26	C0-01952001	74VHCT541AMTCX IC16		1/1/S										
27	C0-00921000	TA8428K(S) IC17		1/5/S										
28	C0-01943001	74VHC244MTCX IC18		1/1/S										
29	C0-01943001	74VHC244MTCX IC19		1/1/S										
30	C0-01957001	DM7407MX IC20		1/5/S										
31	C0-01946001	74VHC32MTCX IC21		1/1/S										
32	C0-06762000	EC-N062 TMP95C063FE IC22		1/1/S										
33	C0-01943001	74VHC244MTCX IC23		1/1/S										
34	C0-07768000	IC24		1										
35	C0-01946001	74VHC32MTCX IC25		1/1/S										
36	C0-01562000	IC26		1										
37	C0-06568001	IC27		1										
38	C0-06076001	IC28		1										
39	C0-01941001	74VHC14MTCX IC29		1/1/S										
40	C0-01943001	74VHC244MTCX IC30		1/1/S										
41	E0-06671000	CLC1028-0301 IC31		1/5/S										
42	C0-01935001	74VHC04MTCX IC32		1/1/S										
43	C0-01937001	74VHC08MTCX IC33		1/1/S										
44	C0-01934001	74VHC00MTCX IC34		1/1/S										
45	C0-01946001	74VHC32MTCX		1/1/S										

ITEM NO.	PARTS NO.	PARTS NAME	Q'TY / PAGE	Q'TY / PACK	P	I	R	BSI NO.	TO	T	FROM	SERIAL NO.	REMARKS	C
46	C0-01935001	IC35 74VHC04MTCX		11/S										
47	C0-07812001	IC36		1										
48	C0-08141001	IC37		1										
49	C0-08141001	IC38		1										
51	C0-01572001	IC39 TA75339F(TP2)		15/S										
52	C0-01937001	IC41 74VHC08MTCX		11/S										
53	C0-01572001	IC42 TA75339F(TP2)		15/S										
54	C0-04597001	IC43 74VHC245MTCX		15/S										
55	C0-01943001	IC44 74VHC244MTCX		11/S										
56	C0-07895000	IC45		1										
57	C0-05984001	IC46		1										
58	C0-08142001	IC47		1										
59	C0-08141001	IC48		1										
60	C0-02021000	IC49 STK672-210		11/S										
61	C0-06860001	IC50		1										
62	C0-07829001	IC51		1										
63	C0-01957001	IC52 DM7407MX		15/S										
64	C0-01957001	IC53 DM7407MX		15/S										
111	C0-02013001	IC54 MAX6001EUR-T		11/S										
151	C0-08136000	IC101		1										
251	C0-08139002	Q1		1										
252	C0-08139002	Q101		1										
253	C0-08138001	Q102		1										
254	C0-08139002	Q103		1										
255	C0-08138001	Q104		1										
256	C0-08138001	Q105		1										
257	C0-08139002	Q106		1										
258	C0-08138001	Q107		1										
259	C0-08138001	Q108		1										
260	C0-08138001	Q109		1										
261	C0-08133002	Q110		1										
262	C0-08138001	Q111		1										
263	C0-08138001	Q112		1										
301	C0-08127002	Q113		1										
		D101		1										

ITEM NO.	PARTS NO.	PARTS NAME	Q'TY / PAGE	Q'TY / PACK	P	I	R	BSI NO.	TO	T	FROM	SERIAL NO.	REMARKS	C
302	C0-08127002	D102	1											
303	C0-08127002	D103	1											
304	C0-08127002	D104	1											
305	C0-08127002	D105	1											
306	C0-08186001	D106	1											
308	C0-08127002	D108	1											
309	C0-08127002	D109	1											
310	C0-08186001	D110	1											
401	C0-08130001	ZD101	1											
402	C0-08909001	ZD102	1											
403	C0-08129001	ZD103	1											
451	D0-16818001	C1	1											
452	D0-16841001	C2	1											
453	D0-16813001	C3	1											
454	D0-16812001	C4	1											
455	D0-16818001	C5	1											
456	D0-16820001	C6	1											
457	D0-16814001	C7	1											
458	D0-16831001	C8	1											
459	D0-16820001	C9	1											
460	D0-16820001	C10	1											
461	D0-16831001	C11	1											
462	D0-16814001	C12	1											
463	D0-16817001	C13	1											
464	D0-16814001	C14	1											
465	D0-16820001	C15	1											
552	D0-04099001	GRM188F11C104ZA01D C102	1	10/P										
553	D0-04099001	GRM188F11C104ZA01D C103	1	10/P										
554	D0-04099001	GRM188F11C104ZA01D C104	1	10/P										
555	D0-04099001	GRM188F11C104ZA01D C105	1	10/P										
556	D0-04099001	GRM188F11C104ZA01D C106	1	10/P										
557	D0-04099001	GRM188F11C104ZA01D C107	1	10/P										
559	D0-05722001	GRM219F11H104ZA01D C109	1	10/P										
560	D0-04099001	GRM188F11C104ZA01D C110	1	10/P										
561	D0-05722001	GRM219F11H104ZA01D	1	10/P										

ITEM NO.	PARTS NO.	PARTS NAME	Q'TY / PAGE	Q'TY / PACK	PIR	BSI NO.	TO	T	FROM	SERIAL NO.	REMARKS	C
		C111										
562	D0-04099001	GRM188F11C104ZA01D		1/10/P								
		C112										
563	D0-04099001	GRM188F11C104ZA01D		1/10/P								
		C113										
564	D0-04099001	GRM188F11C104ZA01D		1/10/P								
		C114										
565	D0-04099001	GRM188F11C104ZA01D		1/10/P								
		C115										
566	D0-05722001	GRM219F11H104ZA01D		1/10/P								
		C116										
567	D0-04099001	GRM188F11C104ZA01D		1/10/P								
		C117										
568	D0-04099001	GRM188F11C104ZA01D		1/10/P								
		C118										
569	D0-04099001	GRM188F11C104ZA01D		1/10/P								
		C119										
570	D0-04099001	GRM188F11C104ZA01D		1/10/P								
		C120										
571	D0-04099001	GRM188F11C104ZA01D		1/10/P								
		C121										
572	D0-04099001	GRM188F11C104ZA01D		1/10/P								
		C122										
573	D0-04099001	GRM188F11C104ZA01D		1/10/P								
		C123										
574	D0-05722001	GRM219F11H104ZA01D		1/10/P								
		C124										
575	D0-04099001	GRM188F11C104ZA01D		1/10/P								
		C125										
576	D0-04099001	GRM188F11C104ZA01D		1/10/P								
		C126										
577	D0-04099001	GRM188F11C104ZA01D		1/10/P								
		C127										
578	D0-04099001	GRM188F11C104ZA01D		1/10/P								
		C128										
579	D0-05722001	GRM219F11H104ZA01D		1/10/P								
		C129										
580	D0-05722001	GRM219F11H104ZA01D		1/10/P								
		C130										
581	D0-04099001	GRM188F11C104ZA01D		1/10/P								
		C131										
582	D0-04099001	GRM188F11C104ZA01D		1/10/P								
		C132										
583	D0-04099001	GRM188F11C104ZA01D		1/10/P								
		C133										
584	D0-05722001	GRM219F11H104ZA01D		1/10/P								
		C134										
585	D0-04099001	GRM188F11C104ZA01D		1/10/P								
		C135										
586	D0-05722001	GRM219F11H104ZA01D		1/10/P								
		C136										
587	D0-04099001	GRM188F11C104ZA01D		1/10/P								
		C137										
588	D0-04099001	GRM188F11C104ZA01D		1/10/P								
		C138										
589	D0-04099001	GRM188F11C104ZA01D		1/10/P								
		C139										
590	D0-04099001	GRM188F11C104ZA01D		1/10/P								
		C140										
591	D0-07512001	GRM188B11E223KA01D		1/10/P								
		C141										
592	D0-04099001	GRM188F11C104ZA01D		1/10/P								
		C142										
593	D0-04099001	GRM188F11C104ZA01D		1/10/P								
		C143										
594	D0-04099001	GRM188F11C104ZA01D		1/10/P								
		C144										
595	D0-05722001	GRM219F11H104ZA01D		1/10/P								
		C145										

ITEM NO.	PARTS NO.	PARTS NAME	Q'TY / PAGE	Q'TY / PACK	PIR	BSI NO.	TO	T	FROM	SERIAL NO.	REMARKS	C
596	D0-05722001	GRM219F11H104ZA01D C146		1/10/P								
597	D0-04099001	GRM188F11C104ZA01D C147		1/10/P								
598	D0-04099001	GRM188F11C104ZA01D C148		1/10/P								
599	D0-04099001	GRM188F11C104ZA01D C149		1/10/P								
600	D0-05722001	GRM219F11H104ZA01D C150		1/10/P								
601	D0-04099001	GRM188F11C104ZA01D C151		1/10/P								
602	D0-07518001	GRM188B11H471KA01D C152		1/10/P								
603	D0-04102001	GRM1882C1H101JA01D C153		1/10/P								
605	D0-04099001	GRM188F11C104ZA01D C155		1/10/P								
606	D0-04099001	GRM188F11C104ZA01D C156		1/10/P								
607	D0-04092001	GRM188B11H222KA01D C157		1/10/P								
608	D0-04092001	GRM188B11H222KA01D C158		1/10/P								
609	D0-04099001	GRM188F11C104ZA01D C159		1/10/P								
610	D0-04099001	GRM188F11C104ZA01D C160		1/10/P								
611	D0-04099001	GRM188F11C104ZA01D C161		1/10/P								
612	D0-04099001	GRM188F11C104ZA01D C162		1/10/P								
613	D0-04099001	GRM188F11C104ZA01D C163		1/10/P								
614	D0-04099001	GRM188F11C104ZA01D C164		1/10/P								
615	D0-04099001	GRM188F11C104ZA01D C165		1/10/P								
616	D0-04099001	GRM188F11C104ZA01D C166		1/10/P								
617	D0-04099001	GRM188F11C104ZA01D C167		1/10/P								
618	D0-04099001	GRM188F11C104ZA01D C168		1/10/P								
619	D0-04099001	GRM188F11C104ZA01D C169		1/10/P								
620	D0-04099001	GRM188F11C104ZA01D C170		1/10/P								
621	D0-04099001	GRM188F11C104ZA01D C171		1/10/P								
622	D0-04099001	GRM188F11C104ZA01D C172		1/10/P								
623	D0-04099001	GRM188F11C104ZA01D C173		1/10/P								
624	D0-04099001	GRM188F11C104ZA01D C174		1/10/P								
625	D0-07518001	GRM188B11H471KA01D C175		1/10/P								
626	D0-04092001	GRM188B11H222KA01D C176		1/10/P								
627	D0-04099001	GRM188F11C104ZA01D C177		1/10/P								
628	D0-04092001	GRM188B11H222KA01D C178		1/10/P								
629	D0-04099001	GRM188F11C104ZA01D C179		1/10/P								
630	D0-04099001	GRM188F11C104ZA01D C180		1/10/P								
631	D0-05722001	GRM219F11H104ZA01D		1/10/P								

ITEM NO.	PARTS NO.	PARTS NAME	Q'TY / PAGE	Q'TY / PACK	PIR	BSI NO.	TO	T	FROM	SERIAL NO.	REMARKS	C
632	D0-04099001	C181 GRM188F11C104ZA01D		1/10/P								
633	D0-07518001	C182 GRM188B11H471KA01D		1/10/P								
634	D0-04099001	C183 GRM188F11C104ZA01D		1/10/P								
635	D0-04099001	C184 GRM188F11C104ZA01D		1/10/P								
636	D0-04085001	C185 GRM1882C1H100JZ01D		1/10/P								
637	D0-04085001	C186 GRM1882C1H100JZ01D		1/10/P								
638	D0-04099001	C187 GRM188F11C104ZA01D		1/10/P								
639	D0-04099001	C188 GRM188F11C104ZA01D		1/10/P								
640	D0-04099001	C189 GRM188F11C104ZA01D		1/10/P								
641	D0-04099001	C190 GRM188F11C104ZA01D		1/10/P								
642	D0-04099001	C191 GRM188F11C104ZA01D		1/10/P								
643	D0-04099001	C192 GRM188F11C104ZA01D		1/10/P								
644	D0-04099001	C193 GRM188F11C104ZA01D		1/10/P								
645	D0-04099001	C194 GRM188F11C104ZA01D		1/10/P								
646	D0-04099001	C195 GRM188F11C104ZA01D		1/10/P								
647	D0-04099001	C196 GRM188F11C104ZA01D		1/10/P								
648	D0-04099001	C197 GRM188F11C104ZA01D		1/10/P								
649	D0-04099001	C198 GRM188F11C104ZA01D		1/10/P								
650	D0-04092001	C199 GRM188B11H222KA01D		1/10/P								
651	D0-04085001	C200 GRM1882C1H100JZ01D		1/10/P								
652	D0-04085001	C201 GRM1882C1H100JZ01D		1/10/P								
653	D0-04099001	C202 GRM188F11C104ZA01D		1/10/P								
654	D0-04099001	C203 GRM188F11C104ZA01D		1/10/P								
655	D0-04099001	C204 GRM188F11C104ZA01D		1/10/P								
656	D0-04099001	C205 GRM188F11C104ZA01D		1/10/P								
657	D0-04099001	C206 GRM188F11C104ZA01D		1/10/P								
658	D0-04099001	C207 GRM188F11C104ZA01D		1/10/P								
659	D0-04099001	C208 GRM188F11C104ZA01D		1/10/P								
660	D0-04099001	C209 GRM188F11C104ZA01D		1/10/P								
661	D0-04099001	C210 GRM188F11C104ZA01D		1/10/P								
662	D0-04099001	C211 GRM188F11C104ZA01D		1/10/P								
663	D0-04099001	C212 GRM188F11C104ZA01D		1/10/P								
664	D0-04099001	C213 GRM188F11C104ZA01D		1/10/P								
665	D0-04099001	C214 GRM188F11C104ZA01D		1/10/P								
		C215										

ITEM NO.	PARTS NO.	PARTS NAME	Q'TY / PAGE	Q'TY / PACK	P	I	R	B S I NO.	T O	T	F R O M	S E R I A L NO.	R E M A R K S	C
666	D0-04099001	GRM188F11C104ZA01D C216		1/10/P										
667	D0-04092001	GRM188B11H222KA01D C217		1/10/P										
668	D0-04099001	GRM188F11C104ZA01D C218		1/10/P										
669	D0-04099001	GRM188F11C104ZA01D C219		1/10/P										
670	D0-04099001	GRM188F11C104ZA01D C220		1/10/P										
671	D0-04099001	GRM188F11C104ZA01D C221		1/10/P										
672	D0-05722001	GRM219F11H104ZA01D C222		1/10/P										
673	D0-04099001	GRM188F11C104ZA01D C223		1/10/P										
674	D0-04099001	GRM188F11C104ZA01D C224		1/10/P										
675	D0-04099001	GRM188F11C104ZA01D C225		1/10/P										
676	D0-04099001	GRM188F11C104ZA01D C226		1/10/P										
677	D0-04099001	GRM188F11C104ZA01D C227		1/10/P										
678	D0-04099001	GRM188F11C104ZA01D C228		1/10/P										
679	D0-04099001	GRM188F11C104ZA01D C229		1/10/P										
680	D0-04099001	GRM188F11C104ZA01D C230		1/10/P										
681	D0-04099001	GRM188F11C104ZA01D C231		1/10/P										
682	D0-04099001	GRM188F11C104ZA01D C232		1/10/P										
683	D0-04099001	GRM188F11C104ZA01D C233		1/10/P										
684	D0-04099001	GRM188F11C104ZA01D C234		1/10/P										
685	D0-04099001	GRM188F11C104ZA01D C235		1/10/P										
686	D0-04099001	GRM188F11C104ZA01D C236		1/10/P										
687	D0-04093001	GRM1882C1H220JZ01D C237		1/10/P										
688	D0-04099001	GRM188F11C104ZA01D C238		1/10/P										
689	D0-04099001	GRM188F11C104ZA01D C239		1/10/P										
690	D0-04099001	GRM188F11C104ZA01D C240		1/10/P										
691	D0-04099001	GRM188F11C104ZA01D C241		1/10/P										
692	D0-04099001	GRM188F11C104ZA01D C242		1/10/P										
693	D0-04099001	GRM188F11C104ZA01D C243		1/10/P										
694	D0-04099001	GRM188F11C104ZA01D C244		1/10/P										
695	D0-04099001	GRM188F11C104ZA01D C245		1/10/P										
696	D0-04099001	GRM188F11C104ZA01D C246		1/10/P										
697	D0-04093001	GRM1882C1H220JZ01D C247		1/10/P										
698	D0-04093001	GRM1882C1H220JZ01D C248		1/10/P										
699	D0-04099001	GRM188F11C104ZA01D C249		1/10/P										
700	D0-04099001	GRM188F11C104ZA01D		1/10/P										

ITEM NO.	PARTS NO.	PARTS NAME	Q'TY / PAGE	Q'TY / PACK	PIR	BSI NO.	TO	T	FROM	SERIAL NO.	REMARKS	C
701	D0-05722001	C250 GRM219F11H104ZA01D		1/10/P								
702	D0-04093001	C251 GRM1882C1H220JZ01D		1/10/P								
703	D0-04093001	C252 GRM1882C1H220JZ01D		1/10/P								
704	D0-04093001	C253 GRM1882C1H220JZ01D		1/10/P								
705	D0-05722001	C254 GRM219F11H104ZA01D		1/10/P								
706	D0-05722001	C255 GRM219F11H104ZA01D		1/10/P								
707	D0-05722001	C256 GRM219F11H104ZA01D		1/10/P								
708	D0-05722001	C257 GRM219F11H104ZA01D		1/10/P								
709	D0-04099001	C258 GRM188F11C104ZA01D		1/10/P								
710	D0-04099001	C259 GRM188F11C104ZA01D		1/10/P								
711	D0-04099001	C260 GRM188F11C104ZA01D		1/10/P								
712	D0-04099001	C261 GRM188F11C104ZA01D		1/10/P								
713	D0-04099001	C262 GRM188F11C104ZA01D		1/10/P								
714	D0-04099001	C263 GRM188F11C104ZA01D		1/10/P								
715	D0-04099001	C264 GRM188F11C104ZA01D		1/10/P								
716	D0-04099001	C265 GRM188F11C104ZA01D		1/10/P								
717	D0-04099001	C266 GRM188F11C104ZA01D		1/10/P								
718	D0-04093001	C267 GRM1882C1H220JZ01D		1/10/P								
719	D0-04093001	C268 GRM1882C1H220JZ01D		1/10/P								
721	D0-04093001	C269 GRM1882C1H220JZ01D		1/10/P								
722	D0-04093001	C271 GRM1882C1H220JZ01D		1/10/P								
723	D0-04099001	C272 GRM188F11C104ZA01D		1/10/P								
724	D0-04093001	C273 GRM1882C1H220JZ01D		1/10/P								
725	D0-04093001	C274 GRM1882C1H220JZ01D		1/10/P								
726	D0-04093001	C275 GRM1882C1H220JZ01D		1/10/P								
727	D0-04101001	C276 GRM188B11H102KA01D		1/10/P								
728	D0-04099001	C277 GRM188F11C104ZA01D		1/10/P								
729	D0-04099001	C278 GRM188F11C104ZA01D		1/10/P								
730	D0-04101001	C279 GRM188B11H102KA01D		1/10/P								
731	D0-04101001	C280 GRM188B11H102KA01D		1/10/P								
732	D0-04099001	C281 GRM188F11C104ZA01D		1/10/P								
733	D0-04099001	C282 GRM188F11C104ZA01D		1/10/P								
734	D0-04101001	C283 GRM188B11H102KA01D		1/10/P								
735	D0-07487001	C284 GRM1882C1H180JZ01D		1/10/P								
		C285										

ITEM NO.	PARTS NO.	PARTS NAME	Q'TY / PAGE	Q'TY / PACK	PIR	BSI NO.	TO	T	FROM	SERIAL NO.	REMARKS	C
736	D0-04101001	GRM188B11H102KA01D C286		1/10/P								
737	D0-04099001	GRM188F11C104ZA01D C287		1/10/P								
738	D0-04101001	GRM188B11H102KA01D C288		1/10/P								
739	D0-04100001	GRM188B11H103KA01D C289		1/10/P								
740	D0-04101001	GRM188B11H102KA01D C290		1/10/P								
741	D0-04101001	GRM188B11H102KA01D C291		1/10/P								
742	D0-04099001	GRM188F11C104ZA01D C292		1/10/P								
743	D0-04101001	GRM188B11H102KA01D C293		1/10/P								
744	D0-04099001	GRM188F11C104ZA01D C294		1/10/P								
745	D0-04101001	GRM188B11H102KA01D C295		1/10/P								
746	D0-04099001	GRM188F11C104ZA01D C296		1/10/P								
747	D0-04101001	GRM188B11H102KA01D C297		1/10/P								
748	D0-04099001	GRM188F11C104ZA01D C298		1/10/P								
749	D0-04099001	GRM188F11C104ZA01D C299		1/10/P								
750	D0-04101001	GRM188B11H102KA01D C300		1/10/P								
751	D0-04101001	GRM188B11H102KA01D C301		1/10/P								
752	D0-04099001	GRM188F11C104ZA01D C302		1/10/P								
753	D0-04099001	GRM188F11C104ZA01D C303		1/10/P								
754	D0-05722001	GRM219F11H104ZA01D C304		1/10/P								
755	D0-04092001	GRM188B11H222KA01D C305		1/10/P								
756	D0-04099001	GRM188F11C104ZA01D C306		1/10/P								
757	D0-04101001	GRM188B11H102KA01D C307		1/10/P								
758	D0-04101001	GRM188B11H102KA01D C308		1/10/P								
759	D0-04099001	GRM188F11C104ZA01D C309		1/10/P								
760	D0-04100001	GRM188B11H103KA01D C310		1/10/P								
761	D0-04099001	GRM188F11C104ZA01D C311		1/10/P								
762	D0-04101001	GRM188B11H102KA01D C312		1/10/P								
763	D0-04099001	GRM188F11C104ZA01D C313		1/10/P								
764	D0-04099001	GRM188F11C104ZA01D C314		1/10/P								
765	D0-04099001	GRM188F11C104ZA01D C315		1/10/P								
766	D0-05722001	GRM219F11H104ZA01D C316		1/10/P								
767	D0-04099001	GRM188F11C104ZA01D C317		1/10/P								
768	D0-04099001	GRM188F11C104ZA01D C318		1/10/P								
769	D0-05722001	GRM219F11H104ZA01D C319		1/10/P								
770	D0-04099001	GRM188F11C104ZA01D		1/10/P								

ITEM NO.	PARTS NO.	PARTS NAME	Q'TY / PAGE	Q'TY / PACK	PIR	BSI NO.	TO	T	FROM	SERIAL NO.	REMARKS	C
771	D0-04099001	C320 GRM188F11C104ZA01D		1/10/P								
772	D0-04101001	C321 GRM188B11H102KA01D		1/10/P								
773	D0-04099001	C322 GRM188F11C104ZA01D		1/10/P								
774	D0-04101001	C323 GRM188B11H102KA01D		1/10/P								
775	D0-07487001	C324 GRM1882C1H180JZ01D		1/10/P								
776	D0-04099001	C325 GRM188F11C104ZA01D		1/10/P								
777	D0-04101001	C326 GRM188B11H102KA01D		1/10/P								
778	D0-04099001	C327 GRM188F11C104ZA01D		1/10/P								
779	D0-04099001	C328 GRM188F11C104ZA01D		1/10/P								
780	D0-04099001	C329 GRM188F11C104ZA01D		1/10/P								
781	D0-04099001	C330 GRM188F11C104ZA01D		1/10/P								
782	D0-04099001	C331 GRM188F11C104ZA01D		1/10/P								
783	D0-05722001	C332 GRM219F11H104ZA01D		1/10/P								
785	D0-04099001	C333 GRM188F11C104ZA01D		1/10/P								
786	D0-04099001	C335 GRM188F11C104ZA01D		1/10/P								
788	D0-04099001	C336 GRM188F11C104ZA01D		1/10/P								
789	D0-04093001	C338 GRM1882C1H220JZ01D		1/10/P								
790	D0-04093001	C339 GRM1882C1H220JZ01D		1/10/P								
791	D0-04093001	C340 GRM1882C1H220JZ01D		1/10/P								
792	D0-04093001	C341 GRM1882C1H220JZ01D		1/10/P								
		C342										

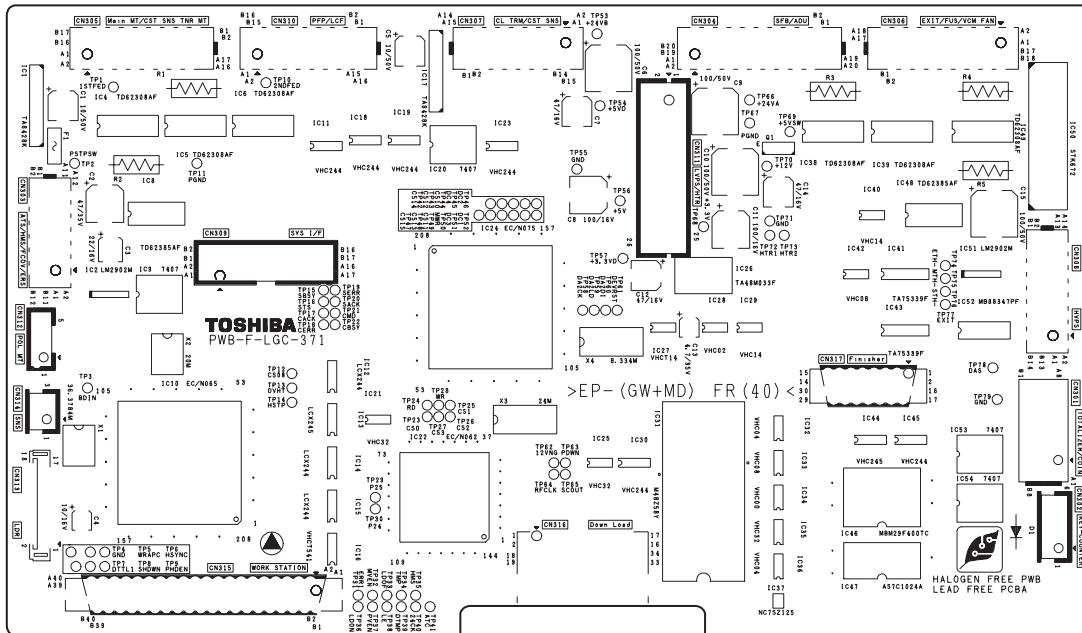

ITEM NO.	PARTS NO.	PARTS NAME	Q'TY / PAGE	Q'TY / PACK	PIR	BSI NO.	TO	T	FROM	SERIAL NO.	REMARKS	C
1	D0-16495000	R1	1									
2	D0-16495000	R2	1									
3	D0-16495000	R3	1									
4	D0-16495000	R4	1									
5	D0-16495000	R5	1									
101	D0-00992001	MCR03EZHZJ271	1	5/								
102	D0-01038001	MCR03EZHZJ682	1	5/								
103	D0-01099001	MCR03EZPF2202	1	5/								
104	D0-00954001	MCR03EZHZJ104	1	10/P								
105	D0-01052001	MCR03EZPF1001	1	10/P								
106	D0-01052001	MCR03EZPF1001	1	10/P								
107	D0-01052001	MCR03EZPF1001	1	10/P								
108	D0-01099001	MCR03EZPF2202	1	5/								
109	D0-01052001	MCR03EZPF1001	1	10/P								
110	D0-01052001	MCR03EZPF1001	1	10/P								
111	D0-01099001	MCR03EZPF2202	1	5/								
112	D0-01099001	MCR03EZPF2202	1	5/								
113	D0-01052001	MCR03EZPF1001	1	10/P								
114	D0-00981001	MCR03EZHZJ220	1	10/P								
115	D0-00951001	MCR03EZHZJ101	1	10/P								
116	D0-00951001	MCR03EZHZJ101	1	10/P								
117	D0-00951001	MCR03EZHZJ101	1	10/P								
118	D0-01037001	MCR03EZHZJ681	1	5/								
119	D0-01037001	MCR03EZHZJ681	1	5/								
120	D0-01037001	MCR03EZHZJ681	1	5/								
121	D0-01149001	MCR03EZPF4701	1	5/								
122	D0-01176001	MCR03EZPF6800	1	5/								
123	D0-01089001	R123	1									
124	D0-01149001	MCR03EZPF4701	1	5/								
125	D0-01053001	MCR03EZPF1002	1	10/P								
126	D0-01098001	MCR03EZPF2201	1	5/								
127	D0-01053001	MCR03EZPF1002	1	10/P								
128	D0-01052001	MCR03EZPF1001	1	10/P								
129	D0-01098001	MCR03EZPF2201	1	5/								
130	D0-00981001	MCR03EZHZJ220	1	10/P								

ITEM NO.	PARTS NO.	PARTS NAME	Q'TY / PAGE	Q'TY / PACK	PIR	BSI NO.	TO	T	FROM	SERIAL NO.	REMARKS	C
131	D0-00981001	R130 MCR03EZHZJ220		1/10/P								
132	D0-00981001	R131 MCR03EZHZJ220		1/10/P								
133	D0-00981001	R132 MCR03EZHZJ220		1/10/P								
134	D0-00981001	R133 MCR03EZHZJ220		1/10/P								
135	D0-01020001	R134 MCR03EZHZJ472		1/10/P								
136	D0-01020001	R135 MCR03EZHZJ472		1/10/P								
137	D0-01020001	R136 MCR03EZHZJ472		1/10/P								
138	D0-01020001	R137 MCR03EZHZJ472		1/10/P								
139	D0-01020001	R138 MCR03EZHZJ472		1/10/P								
140	D0-01020001	R139 MCR03EZHZJ472		1/10/P								
141	D0-01020001	R140 MCR03EZHZJ472		1/10/P								
142	D0-01052001	R141 MCR03EZPFX1001		1/10/P								
143	D0-00951001	R142 MCR03EZHZJ101		1/10/P								
144	D0-00951001	R143 MCR03EZHZJ101		1/10/P								
145	D0-01176001	R144 MCR03EZPFX6800		1/5/								
146	D0-01149001	R145 MCR03EZPFX4701		1/5/								
147	D0-01052001	R146 MCR03EZPFX1001		1/10/P								
148	D0-01089001	R147		1/								
149	D0-01149001	R148 MCR03EZPFX4701		1/5/								
150	D0-01176001	R149 MCR03EZPFX6800		1/5/								
151	D0-01052001	R150 MCR03EZPFX1001		1/10/P								
152	D0-01149001	R151 MCR03EZPFX4701		1/5/								
153	D0-01089001	R152		1/								
154	D0-01149001	R153 MCR03EZPFX4701		1/5/								
155	D0-01052001	R154 MCR03EZPFX1001		1/10/P								
156	D0-01098001	R155 MCR03EZPFX2201		1/5/								
157	D0-00951001	R156 MCR03EZHZJ101		1/10/P								
158	D0-00951001	R157 MCR03EZHZJ101		1/10/P								
159	D0-01089001	R158		1/								
160	D0-01149001	R159 MCR03EZPFX4701		1/5/								
161	D0-01053001	R160 MCR03EZPFX1002		1/10/P								
162	D0-01052001	R161 MCR03EZPFX1001		1/10/P								
163	D0-01089001	R162		1/								
164	D0-01149001	R163 MCR03EZPFX4701		1/5/								
		R164										

ITEM NO.	PARTS NO.	PARTS NAME	Q'TY / PAGE	Q'TY / PACK	PIR	BSI NO.	TO	T	FROM	SERIAL NO.	REMARKS	C
165	D0-01089001	R165	1									
166	D0-01149001	MCR03EZPF4701 R166	1	5								
167	D0-00981001	MCR03EZHJ220 R167	1	10	P							
168	D0-00981001	MCR03EZHJ220 R168	1	10	P							
169	D0-00981001	MCR03EZHJ220 R169	1	10	P							
170	D0-00981001	MCR03EZHJ220 R170	1	10	P							
171	D0-00981001	MCR03EZHJ220 R171	1	10	P							
172	D0-00981001	MCR03EZHJ220 R172	1	10	P							
173	D0-00981001	MCR03EZHJ220 R173	1	10	P							
174	D0-00981001	MCR03EZHJ220 R174	1	10	P							
175	D0-00981001	MCR03EZHJ220 R175	1	10	P							
176	D0-01020001	MCR03EZHJ472 R176	1	10	P							
177	D0-01020001	MCR03EZHJ472 R177	1	10	P							
178	D0-01020001	MCR03EZHJ472 R178	1	10	P							
179	D0-01020001	MCR03EZHJ472 R179	1	10	P							
180	D0-01020001	MCR03EZHJ472 R180	1	10	P							
181	D0-01020001	MCR03EZHJ472 R181	1	10	P							
182	D0-01020001	MCR03EZHJ472 R182	1	10	P							
183	D0-01020001	MCR03EZHJ472 R183	1	10	P							
184	D0-00981001	MCR03EZHJ220 R184	1	10	P							
185	D0-00981001	MCR03EZHJ220 R185	1	10	P							
186	D0-01020001	MCR03EZHJ472 R186	1	10	P							
187	D0-00951001	MCR03EZHJ101 R187	1	10	P							
188	D0-01020001	MCR03EZHJ472 R188	1	10	P							
189	D0-01036001	MCR03EZHJ680 R189	1	10	P							
190	D0-01020001	MCR03EZHJ472 R190	1	10	P							
191	D0-01004001	MCR03EZHJ332 R191	1	10	P							
192	D0-00981001	MCR03EZHJ220 R192	1	10	P							
193	D0-00952001	MCR03EZHJ102 R193	1	10	P							
194	D0-00953001	MCR03EZHJ103 R194	1	10	P							
195	D0-00952001	MCR03EZHJ102 R195	1	10	P							
196	D0-00953001	MCR03EZHJ103 R196	1	10	P							
197	D0-01020001	MCR03EZHJ472 R197	1	10	P							
198	D0-00951001	MCR03EZHJ101 R198	1	10	P							
199	D0-00951001	MCR03EZHJ101	1	10	P							

ITEM NO.	PARTS NO.	PARTS NAME	Q'TY / PAGE	Q'TY / PACK	PIR	BSI NO.	TO	T	FROM	SERIAL NO.	REMARKS	C
		R199										
200	D0-00951001	MCR03EZHJ101		1/10/P								
		R200										
201	D0-00951001	MCR03EZHJ101		1/10/P								
		R201										
202	D0-00949001	MCR03EZHJ000		1/10/P								
		R202										
204	D0-01020001	MCR03EZHJ472		1/10/P								
		R204										
205	D0-01020001	MCR03EZHJ472		1/10/P								
		R205										
206	D0-01020001	MCR03EZHJ472		1/10/P								
		R206										
207	D0-01020001	MCR03EZHJ472		1/10/P								
		R207										
208	D0-01020001	MCR03EZHJ472		1/10/P								
		R208										
209	D0-01020001	MCR03EZHJ472		1/10/P								
		R209										
210	D0-01020001	MCR03EZHJ472		1/10/P								
		R210										
211	D0-01020001	MCR03EZHJ472		1/10/P								
		R211										
212	D0-01020001	MCR03EZHJ472		1/10/P								
		R212										
213	D0-01020001	MCR03EZHJ472		1/10/P								
		R213										
214	D0-01020001	MCR03EZHJ472		1/10/P								
		R214										
215	D0-01020001	MCR03EZHJ472		1/10/P								
		R215										
216	D0-01003001	MCR03EZHJ331		1/10/P								
		R216										
217	D0-01003001	MCR03EZHJ331		1/10/P								
		R217										
218	D0-01003001	MCR03EZHJ331		1/10/P								
		R218										
219	D0-00953001	MCR03EZHJ103		1/10/P								
		R219										
220	D0-00952001	MCR03EZHJ102		1/10/P								
		R220										
221	D0-01020001	MCR03EZHJ472		1/10/P								
		R221										
222	D0-01020001	MCR03EZHJ472		1/10/P								
		R222										
223	D0-01020001	MCR03EZHJ472		1/10/P								
		R223										
224	D0-01020001	MCR03EZHJ472		1/10/P								
		R224										
225	D0-01020001	MCR03EZHJ472		1/10/P								
		R225										
226	D0-01020001	MCR03EZHJ472		1/10/P								
		R226										
227	D0-01020001	MCR03EZHJ472		1/10/P								
		R227										
228	D0-01020001	MCR03EZHJ472		1/10/P								
		R228										
229	D0-01020001	MCR03EZHJ472		1/10/P								
		R229										
230	D0-00951001	MCR03EZHJ101		1/10/P								
		R230										
231	D0-00949001	MCR03EZHJ000		1/10/P								
		R231										
233	D0-00984001	MCR03EZHJ223		1/10/P								
		R233										
234	D0-01020001	MCR03EZHJ472		1/10/P								
		R234										
235	D0-00951001	MCR03EZHJ101		1/10/P								
		R235										

ITEM NO.	PARTS NO.	PARTS NAME	Q'TY / PAGE	Q'TY / PACK	P	I	R	B S I NO.	T O	T	F R O M	S E R I A L NO.	R E M A R K S	C
237	D0-00952001	MCR03EZHJ102 R237		1/10/P										
238	D0-01020001	MCR03EZHJ472 R238		1/10/P										
239	D0-00983001	MCR03EZHJ222 R239		1/10/P										
241	D0-00981001	MCR03EZHJ220 R241		1/10/P										
242	D0-00981001	MCR03EZHJ220 R242		1/10/P										
243	D0-00981001	MCR03EZHJ220 R243		1/10/P										
244	D0-00951001	MCR03EZHJ101 R244		1/10/P										
245	D0-00951001	MCR03EZHJ101 R245		1/10/P										
246	D0-01037001	MCR03EZHJ681 R246		1/5/										
247	D0-00949001	MCR03EZHJ000 R247		1/10/P										
248	D0-00949001	MCR03EZHJ000 R248		1/10/P										
249	D0-01020001	MCR03EZHJ472 R249		1/10/P										
250	D0-01020001	MCR03EZHJ472 R250		1/10/P										
251	D0-01020001	MCR03EZHJ472 R251		1/10/P										
252	D0-00951001	MCR03EZHJ101 R252		1/10/P										
253	D0-00951001	MCR03EZHJ101 R253		1/10/P										
254	D0-00949001	MCR03EZHJ000 R254		1/10/P										
256	D0-00984001	MCR03EZHJ223 R256		1/10/P										
257	D0-00984001	MCR03EZHJ223 R257		1/10/P										
258	D0-00984001	MCR03EZHJ223 R258		1/10/P										
259	D0-00951001	MCR03EZHJ101 R259		1/10/P										
260	D0-00951001	MCR03EZHJ101 R260		1/10/P										
261	D0-01019001	MCR03EZHJ471 R261		1/5/										
262	D0-00955001	MCR03EZHJ105 R262		1/10/P										
263	D0-01020001	MCR03EZHJ472 R263		1/10/P										
264	D0-01020001	MCR03EZHJ472 R264		1/10/P										
265	D0-01020001	MCR03EZHJ472 R265		1/10/P										
266	D0-01020001	MCR03EZHJ472 R266		1/10/P										
267	D0-01020001	MCR03EZHJ472 R267		1/10/P										
268	D0-01020001	MCR03EZHJ472 R268		1/10/P										
269	D0-01020001	MCR03EZHJ472 R269		1/10/P										
270	D0-01020001	MCR03EZHJ472 R270		1/10/P										
271	D0-01020001	MCR03EZHJ472 R271		1/10/P										
272	D0-01020001	MCR03EZHJ472 R272		1/10/P										
273	D0-00984001	MCR03EZHJ223		1/10/P										

ITEM NO.	PARTS NO.	PARTS NAME	Q'TY / PAGE	Q'TY / PACK	PIR	BSI NO.	TO	T	FROM	SERIAL NO.	REMARKS	C
		R273										
274	D0-00984001	MCR03EZHZJ223		1/10/P								
		R274										
275	D0-00984001	MCR03EZHZJ223		1/10/P								
		R275										
276	D0-00984001	MCR03EZHZJ223		1/10/P								
		R276										
277	D0-00984001	MCR03EZHZJ223		1/10/P								
		R277										
278	D0-00984001	MCR03EZHZJ223		1/10/P								
		R278										
279	D0-00984001	MCR03EZHZJ223		1/10/P								
		R279										
280	D0-00984001	MCR03EZHZJ223		1/10/P								
		R280										
281	D0-00984001	MCR03EZHZJ223		1/10/P								
		R281										
284	D0-01020001	MCR03EZHZJ472		1/10/P								
		R284										
285	D0-00984001	MCR03EZHZJ223		1/10/P								
		R285										
286	D0-01020001	MCR03EZHZJ472		1/10/P								
		R286										
287	D0-00984001	MCR03EZHZJ223		1/10/P								
		R287										
288	D0-00984001	MCR03EZHZJ223		1/10/P								
		R288										
289	D0-00984001	MCR03EZHZJ223		1/10/P								
		R289										
290	D0-00984001	MCR03EZHZJ223		1/10/P								
		R290										
291	D0-00984001	MCR03EZHZJ223		1/10/P								
		R291										
292	D0-00984001	MCR03EZHZJ223		1/10/P								
		R292										
293	D0-00984001	MCR03EZHZJ223		1/10/P								
		R293										
294	D0-00984001	MCR03EZHZJ223		1/10/P								
		R294										
295B	D0-00951001	MCR03EZHZJ101		1/10/P							e-STUDIO280	
		R295									0	
296	D0-00951001	MCR03EZHZJ101		1/10/P								
		R296										
298	D0-01020001	MCR03EZHZJ472		1/10/P								
		R298										
299	D0-01020001	MCR03EZHZJ472		1/10/P								
		R299										
300	D0-00984001	MCR03EZHZJ223		1/10/P								
		R300										
301	D0-00984001	MCR03EZHZJ223		1/10/P								
		R301										
302	D0-00951001	MCR03EZHZJ101		1/10/P								
		R302										
304	D0-01020001	MCR03EZHZJ472		1/10/P								
		R304										
305	D0-01020001	MCR03EZHZJ472		1/10/P								
		R305										
306	D0-01020001	MCR03EZHZJ472		1/10/P								
		R306										
307	D0-01020001	MCR03EZHZJ472		1/10/P								
		R307										
308	D0-01020001	MCR03EZHZJ472		1/10/P								
		R308										
309	D0-01020001	MCR03EZHZJ472		1/10/P								
		R309										
310	D0-01020001	MCR03EZHZJ472		1/10/P								
		R310										
311	D0-00951001	MCR03EZHZJ101		1/10/P								
		R311										

ITEM NO.	PARTS NO.	PARTS NAME	Q'TY / PAGE	Q'TY / PACK	PIR	BSI NO.	TO	T	FROM	SERIAL NO.	REMARKS	C
312	D0-00951001	MCR03EZHJ101 R312		1/10/P								
313	D0-01020001	MCR03EZHJ472 R313		1/10/P								
314	D0-01020001	MCR03EZHJ472 R314		1/10/P								
318	D0-00984001	MCR03EZHJ223 R318		1/10/P								
321	D0-00951001	MCR03EZHJ101 R321		1/10/P								
322	D0-00984001	MCR03EZHJ223 R322		1/10/P								
323	D0-00984001	MCR03EZHJ223 R323		1/10/P								
324	D0-01020001	MCR03EZHJ472 R324		1/10/P								
325	D0-01020001	MCR03EZHJ472 R325		1/10/P								
326	D0-00951001	MCR03EZHJ101 R326		1/10/P								
327	D0-01020001	MCR03EZHJ472 R327		1/10/P								
328	D0-01020001	MCR03EZHJ472 R328		1/10/P								
329	D0-00951001	MCR03EZHJ101 R329		1/10/P								
330	D0-00951001	MCR03EZHJ101 R330		1/10/P								
331	D0-01020001	MCR03EZHJ472 R331		1/10/P								
332	D0-01020001	MCR03EZHJ472 R332		1/10/P								
333	D0-01020001	MCR03EZHJ472 R333		1/10/P								
334	D0-01020001	MCR03EZHJ472 R334		1/10/P								
335	D0-01020001	MCR03EZHJ472 R335		1/10/P								
336	D0-01020001	MCR03EZHJ472 R336		1/10/P								
337	D0-01020001	MCR03EZHJ472 R337		1/10/P								
338	D0-01020001	MCR03EZHJ472 R338		1/10/P								
339	D0-00951001	MCR03EZHJ101 R339		1/10/P								
340	D0-01020001	MCR03EZHJ472 R340		1/10/P								
341	D0-01020001	MCR03EZHJ472 R341		1/10/P								
342	D0-01020001	MCR03EZHJ472 R342		1/10/P								
343	D0-01020001	MCR03EZHJ472 R343		1/10/P								
344	D0-01020001	MCR03EZHJ472 R344		1/10/P								
345	D0-01020001	MCR03EZHJ472 R345		1/10/P								
350	D0-00984001	MCR03EZHJ223 R350		1/10/P								
351	D0-01020001	MCR03EZHJ472 R351		1/10/P								
352	D0-01020001	MCR03EZHJ472 R352		1/10/P								
353	D0-01020001	MCR03EZHJ472 R353		1/10/P								
354	D0-00984001	MCR03EZHJ223 R354		1/10/P								
355	D0-00984001	MCR03EZHJ223		1/10/P								

ITEM NO.	PARTS NO.	PARTS NAME	Q'TY / PAGE	Q'TY / PACK	PIR	BSI NO.	TO	T	FROM	SERIAL NO.	REMARKS	C
356	D0-00984001	R355 MCR03EZHZJ223		110/P								
358	D0-01020001	R356 MCR03EZHZJ472		110/P								
359	D0-01020001	R358 MCR03EZHZJ472		110/P								
360	D0-01020001	R359 MCR03EZHZJ472		110/P								
362	D0-00984001	R360 MCR03EZHZJ223		110/P								
363	D0-00984001	R362 MCR03EZHZJ223		110/P								
364	D0-00984001	R363 MCR03EZHZJ223		110/P								
366	D0-00984001	R364 MCR03EZHZJ223		110/P								
367	D0-01020001	R366 MCR03EZHZJ472		110/P								
368	D0-00984001	R367 MCR03EZHZJ223		110/P								
369	D0-01020001	R368 MCR03EZHZJ472		110/P								
370	D0-00984001	R369 MCR03EZHZJ223		110/P								
371	D0-01020001	R370 MCR03EZHZJ472		110/P								
372	D0-00984001	R371 MCR03EZHZJ223		110/P								
373	D0-00984001	R372 MCR03EZHZJ223		110/P								
374	D0-01020001	R373 MCR03EZHZJ472		110/P								
375	D0-01020001	R374 MCR03EZHZJ472		110/P								
376	D0-00984001	R375 MCR03EZHZJ223		110/P								
377	D0-00984001	R376 MCR03EZHZJ223		110/P								
378	D0-00984001	R377 MCR03EZHZJ223		110/P								
379	D0-00984001	R378 MCR03EZHZJ223		110/P								
380	D0-00984001	R379 MCR03EZHZJ223		110/P								
381	D0-00984001	R380 MCR03EZHZJ223		110/P								
382	D0-00984001	R381 MCR03EZHZJ223		110/P								
383	D0-00984001	R382 MCR03EZHZJ223		110/P								
384	D0-00984001	R383 MCR03EZHZJ223		110/P								
385	D0-01021001	R384 MCR03EZHZJ473		110/P								
386	D0-01020001	R385 MCR03EZHZJ472		110/P								
387	D0-00984001	R386 MCR03EZHZJ223		110/P								
388	D0-01099001	R387 MCR03EZPFX2202		15/								
389	D0-01020001	R388 MCR03EZHZJ472		110/P								
390	D0-00984001	R389 MCR03EZHZJ223		110/P								
391	D0-01020001	R390 MCR03EZHZJ472		110/P								
392	D0-00984001	R391 MCR03EZHZJ223		110/P								
		R392										

ITEM NO.	PARTS NO.	PARTS NAME	Q'TY / PAGE	Q'TY / PACK	P	I	R	B S I NO.	T O	T	F R O M	S E R I A L NO.	R E M A R K S	C
393	D0-01020001	MCR03EZHJ472 R393		1/10/P										
394	D0-00984001	MCR03EZHJ223 R394		1/10/P										
395	D0-00984001	MCR03EZHJ223 R395		1/10/P										
396	D0-01020001	MCR03EZHJ472 R396		1/10/P										
397	D0-01020001	MCR03EZHJ472 R397		1/10/P										
398	D0-01020001	MCR03EZHJ472 R398		1/10/P										
399	D0-01020001	MCR03EZHJ472 R399		1/10/P										
400	D0-01020001	MCR03EZHJ472 R400		1/10/P										
401	D0-01020001	MCR03EZHJ472 R401		1/10/P										
402	D0-01020001	MCR03EZHJ472 R402		1/10/P										
403	D0-01020001	MCR03EZHJ472 R403		1/10/P										
404	D0-01020001	MCR03EZHJ472 R404		1/10/P										
405	D0-01020001	MCR03EZHJ472 R405		1/10/P										
406	D0-01020001	MCR03EZHJ472 R406		1/10/P										
407	D0-01020001	MCR03EZHJ472 R407		1/10/P										
408	D0-01125001	MCR03EZPF3301 R408		1/10/P										
409	D0-01098001	MCR03EZPF2201 R409		1/5/										
410	D0-01149001	MCR03EZPF4701 R410		1/5/										
411	D0-00984001	MCR03EZHJ223 R411		1/10/P										
412	D0-00984001	MCR03EZHJ223 R412		1/10/P										
413	D0-01020001	MCR03EZHJ472 R413		1/10/P										
414	D0-00984001	MCR03EZHJ223 R414		1/10/P										
415	D0-01020001	MCR03EZHJ472 R415		1/10/P										
416	D0-00984001	MCR03EZHJ223 R416		1/10/P										
417	D0-01020001	MCR03EZHJ472 R417		1/10/P										
418	D0-00984001	MCR03EZHJ223 R418		1/10/P										
419	D0-01020001	MCR03EZHJ472 R419		1/10/P										
420	D0-00984001	MCR03EZHJ223 R420		1/10/P										
421	D0-01020001	MCR03EZHJ472 R421		1/10/P										
422	D0-00984001	MCR03EZHJ223 R422		1/10/P										
423	D0-01020001	MCR03EZHJ472 R423		1/10/P										
424	D0-00984001	MCR03EZHJ223 R424		1/10/P										
425	D0-01020001	MCR03EZHJ472 R425		1/10/P										
426	D0-00984001	MCR03EZHJ223 R426		1/10/P										
427	D0-01020001	MCR03EZHJ472		1/10/P										

ITEM NO.	PARTS NO.	PARTS NAME	Q'TY / PAGE	Q'TY / PACK	PIR	BSI NO.	TO	T	FROM	SERIAL NO.	REMARKS	C
428	D0-00984001	R427 MCR03EZHZJ223		110/P								
429	D0-01020001	R428 MCR03EZHZJ472		110/P								
430	D0-00984001	R429 MCR03EZHZJ223		110/P								
431	D0-00984001	R430 MCR03EZHZJ223		110/P								
432	D0-00984001	R431 MCR03EZHZJ223		110/P								
433	D0-01020001	R432 MCR03EZHZJ472		110/P								
434	D0-01020001	R433 MCR03EZHZJ472		110/P								
435	D0-01020001	R434 MCR03EZHZJ472		110/P								
436	D0-00951001	R435 MCR03EZHZJ101		110/P								
437	D0-01019001	R436 MCR03EZHZJ471		15/								
438	D0-01019001	R437 MCR03EZHZJ471		15/								
439	D0-01019001	R438 MCR03EZHZJ471		15/								
440	D0-01019001	R439 MCR03EZHZJ471		15/								
441	D0-01004001	R440 MCR03EZHZJ332		110/P								
442	D0-00973001	R441 MCR03EZHZJ181		15/								
443	D0-00951001	R442 MCR03EZHZJ101		110/P								
444	D0-00951001	R443 MCR03EZHZJ101		110/P								
445	D0-00951001	R444 MCR03EZHZJ101		110/P								
446	D0-00951001	R445 MCR03EZHZJ101		110/P								
447	D0-00951001	R446 MCR03EZHZJ101		110/P								
449	D0-01053001	R447 MCR03EZPFX1002		110/P								
450	D0-01053001	R449 MCR03EZPFX1002		110/P								
451	D0-00984001	R450 MCR03EZHZJ223		110/P								
452	D0-01020001	R451 MCR03EZHZJ472		110/P								
453	D0-01075001	R452 MCR03EZPFX1501		15/								
454	D0-01075001	R453 MCR03EZPFX1501		15/								
455	D0-01075001	R454 MCR03EZPFX1501		15/								
456	D0-01004001	R455 MCR03EZHZJ332		110/P								
457	D0-01004001	R456 MCR03EZHZJ332		110/P								
458	D0-00973001	R457 MCR03EZHZJ181		15/								
459	D0-00973001	R458 MCR03EZHZJ181		15/								
460	D0-01020001	R459 MCR03EZHZJ472		110/P								
461	D0-01020001	R460 MCR03EZHZJ472		110/P								
462	D0-01020001	R461 MCR03EZHZJ472		110/P								
		R462										

ITEM NO.	PARTS NO.	PARTS NAME	Q'TY / PAGE	Q'TY / PACK	P	I	R	BSI NO.	TO	T	FROM	SERIAL NO.	REMARKS	C
463	D0-01020001	MCR03EZHZJ472 R463		1/10/P										
464	D0-01020001	MCR03EZHZJ472 R464		1/10/P										
465	D0-01020001	MCR03EZHZJ472 R465		1/10/P										
466	D0-01020001	MCR03EZHZJ472 R466		1/10/P										
467	D0-01020001	MCR03EZHZJ472 R467		1/10/P										
468	D0-01020001	MCR03EZHZJ472 R468		1/10/P										
469	D0-01020001	MCR03EZHZJ472 R469		1/10/P										
470	D0-01020001	MCR03EZHZJ472 R470		1/10/P										
471	D0-01020001	MCR03EZHZJ472 R471		1/10/P										
472	D0-01075001	MCR03EZPFX1501 R472		1/5/										
473	D0-01004001	MCR03EZHZJ332 R473		1/10/P										
474	D0-01004001	MCR03EZHZJ332 R474		1/10/P										
475	D0-01004001	MCR03EZHZJ332 R475		1/10/P										
476	D0-00973001	MCR03EZHZJ181 R476		1/5/										
477	D0-00973001	MCR03EZHZJ181 R477		1/5/										
478	D0-00973001	MCR03EZHZJ181 R478		1/5/										
479	D0-01020001	MCR03EZHZJ472 R479		1/10/P										
480	D0-01020001	MCR03EZHZJ472 R480		1/10/P										
481	D0-01020001	MCR03EZHZJ472 R481		1/10/P										
482	D0-01020001	MCR03EZHZJ472 R482		1/10/P										
483	D0-01020001	MCR03EZHZJ472 R483		1/10/P										
484	D0-01020001	MCR03EZHZJ472 R484		1/10/P										
485	D0-01020001	MCR03EZHZJ472 R485		1/10/P										
486	D0-01020001	MCR03EZHZJ472 R486		1/10/P										
487	D0-01020001	MCR03EZHZJ472 R487		1/10/P										
488	D0-01020001	MCR03EZHZJ472 R488		1/10/P										
489	D0-01020001	MCR03EZHZJ472 R489		1/10/P										
490	D0-01020001	MCR03EZHZJ472 R490		1/10/P										
491	D0-00953001	MCR03EZHZJ103 R491		1/10/P										
492	D0-00983001	MCR03EZHZJ222 R492		1/10/P										
493	D0-00951001	MCR03EZHZJ101 R493		1/10/P										
494	D0-00951001	MCR03EZHZJ101 R494		1/10/P										
495	D0-01004001	MCR03EZHZJ332 R495		1/10/P										
496	D0-01004001	MCR03EZHZJ332 R496		1/10/P										
497	D0-01020001	MCR03EZHZJ472		1/10/P										

ITEM NO.	PARTS NO.	PARTS NAME	Q'TY / PAGE	Q'TY / PACK	PIR	BSI NO.	TO	T	FROM	SERIAL NO.	REMARKS	C
498	D0-01075001	R497 MCR03EZPFX1501		15/								
499	D0-01075001	R498 MCR03EZPFX1501		15/								
500	D0-01063001	R499 MCR03EZPFX1201		110/P								
501	D0-00973001	R500 MCR03EZHZJ181		15/								
502	D0-00973001	R501 MCR03EZHZJ181		15/								
503	D0-00981001	R502 MCR03EZHZJ220		110/P								
504	D0-01019001	R503 MCR03EZHZJ471		15/								
505	D0-01019001	R504 MCR03EZHZJ471		15/								
506	D0-00981001	R505 MCR03EZHZJ220		110/P								
507	D0-00981001	R506 MCR03EZHZJ220		110/P								
508	D0-00981001	R507 MCR03EZHZJ220		110/P								
509	D0-00949001	R508 MCR03EZHZJ000		110/P								
510	D0-00984001	R509 MCR03EZHZJ223		110/P								
511	D0-01036001	R510 MCR03EZHZJ680		110/P								
513	D0-00951001	R511 MCR03EZHZJ101		110/P								
514	D0-01041001	R513 MCR03EZHZJ750		15/								
515	D0-01020001	R514 MCR03EZHZJ472		110/P								
516	D0-01020001	R515 MCR03EZHZJ472		110/P								
517	D0-01037001	R516 MCR03EZHZJ681		15/								
518	D0-00984001	R517 MCR03EZHZJ223		110/P								
519	D0-01076001	R518 MCR03EZPFX1502		15/								
520	D0-01020001	R519 MCR03EZHZJ472		110/P								
521	D0-01020001	R520 MCR03EZHZJ472		110/P								
522	D0-00951001	R521 MCR03EZHZJ101		110/P								
524	D0-00951001	R522 MCR03EZHZJ101		110/P								
525	D0-00984001	R524 MCR03EZHZJ223		110/P								
526	D0-01041001	R525 MCR03EZHZJ750		15/								
527	D0-01020001	R526 MCR03EZHZJ472		110/P								
528	D0-00951001	R527 MCR03EZHZJ101		110/P								
529	D0-00981001	R528 MCR03EZHZJ220		110/P								
530	D0-00984001	R529 MCR03EZHZJ223		110/P								
531	D0-00984001	R530 MCR03EZHZJ223		110/P								
532	D0-01053001	R531 MCR03EZPFX1002		110/P								
533	D0-00949001	R532 MCR03EZHZJ000		110/P								
		R533										

ITEM NO.	PARTS NO.	PARTS NAME	Q'TY / PAGE	Q'TY / PACK	PIR	BSI NO.	TO	T	FROM	SERIAL NO.	REMARKS	C
535	D0-00951001	MCR03EZHJ101 R535		1/10/P								
536	D0-01020001	MCR03EZHJ472 R536		1/10/P								
537	D0-01020001	MCR03EZHJ472 R537		1/10/P								
538	D0-01020001	MCR03EZHJ472 R538		1/10/P								
539	D0-00949001	MCR03EZHJ000 R539		1/10/P								
540	D0-01036001	MCR03EZHJ680 R540		1/10/P								
541	D0-00951001	MCR03EZHJ101 R541		1/10/P								
542	D0-00951001	MCR03EZHJ101 R542		1/10/P								
543	D0-01012001	MCR03EZHJ392 R543		1/5/								
545	D0-00951001	MCR03EZHJ101 R545		1/10/P								
547	D0-01075001	MCR03EZPF1501 R547		1/5/								
548	D0-01052001	MCR03EZPF1001 R548		1/10/P								
549	D0-01020001	MCR03EZHJ472 R549		1/10/P								
550	D0-00949001	MCR03EZHJ000 R550		1/10/P								
551	D0-01038001	MCR03EZHJ682 R551		1/5/								
553	D0-00981001	MCR03EZHJ220 R553		1/10/P								
555	D0-00949001	MCR03EZHJ000 R555		1/10/P								
556	D0-01020001	MCR03EZHJ472 R556		1/10/P								
561	D0-01020001	MCR03EZHJ472 R561		1/10/P								
562	D0-00981001	MCR03EZHJ220 R562		1/10/P								
563	D0-00981001	MCR03EZHJ220 R563		1/10/P								
564	D0-00981001	MCR03EZHJ220 R564		1/10/P								
565	D0-00981001	MCR03EZHJ220 R565		1/10/P								
566	D0-00949001	MCR03EZHJ000 R566		1/10/P								
567	D0-00949001	MCR03EZHJ000 R567		1/10/P								
568	D0-00949001	MCR03EZHJ000 R568		1/10/P								
569	D0-01004001	MCR03EZHJ332 R569		1/10/P								
570	D0-01004001	MCR03EZHJ332 R570		1/10/P								
571	D0-01004001	MCR03EZHJ332 R571		1/10/P								
572	D0-01004001	MCR03EZHJ332 R572		1/10/P								
573	D0-01004001	MCR03EZHJ332 R573		1/10/P								
574	D0-01004001	MCR03EZHJ332 R574		1/10/P								
576	D0-01038001	MCR03EZHJ682 R576		1/5/								
577	D0-01038001	MCR03EZHJ682 R577		1/5/								
578	D0-01038001	MCR03EZHJ682		1/5/								

ITEM NO.	PARTS NO.	PARTS NAME	Q'TY / PAGE	Q'TY / PACK	P	I	R	B S I NO.	T O	T	F R O M	S E R I A L NO.	R E M A R K S	C
579	D0-01038001	R578 MCR03EZHJ682		1/5/										
580	D0-01038001	R579 MCR03EZHJ682		1/5/										
581	D0-01038001	R580 MCR03EZHJ682		1/5/										
582	D0-01038001	R581 MCR03EZHJ682		1/5/										
583	D0-01038001	R582 MCR03EZHJ682		1/5/										
584	D0-01020001	R583 MCR03EZHJ472		1/10/P										
585	D0-00984001	R584 MCR03EZHJ223		1/10/P										
586	D0-01020001	R585 MCR03EZHJ472		1/10/P										
901	E0-06866000	R586 CN301		1/										
902	E0-06855000	CN302		1/										
903A	E0-06770000	CN303		1/									e-STUDIO230	
903B	E0-06771000	B24B-CZWHK-B-1 (LF) CN303		1/5/P									e-STUDIO280	
904	E0-06779000	B40B-CZWHK-B-1 (LF) CN304		1/5/P										
905	E0-06776000	CN305		1/										
906	E0-06777000	CN306		1/										
907	E0-06774000	CN307		1/										
908	E0-06773000	B28B-CZWHK-B-1 (LF) CN308		1/5/P										
909	E0-01712000	CN309		1/										
910	E0-06775000	CN310		1/										
911	E0-07150000	CN311		1/										
912	E0-07147000	CN312		1/										
913	E0-06614001	CN313		1/										
916	E0-02160000	DHB-PA34-R13NNA CN316		1/1/P										
917	E0-00112000	174215-1 CN317		1/1/P										
931	E0-04296000	F1		1/										
951	D0-18793001	X1		1/										
952	D0-18794001	X2		1/										
953	D0-12253001	X3		1/										
954	D0-16117001	X4		1/										

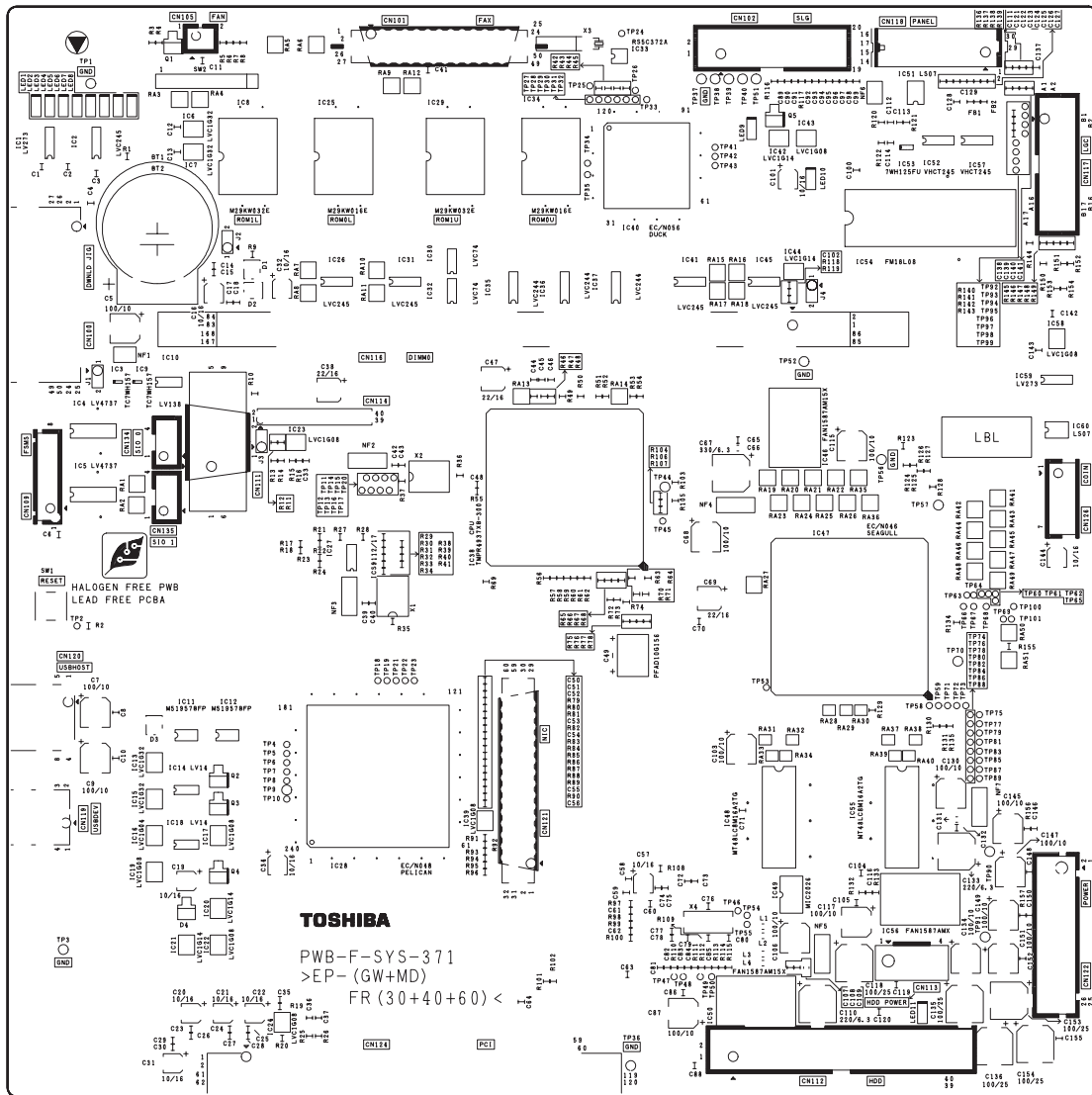

ITEM NO.	PARTS NO.	PARTS NAME	Q'TY / PAGE	Q'TY / PACK	P	I	R	B S I NO.	T O	T	F R O M	S E R I A L NO.	R E M A R K S	C
0	6LA88724000	ASY-PWA-SYS-371S		1/1/SB										
18	C0-07987001	IC8		1										
19	C0-08122001	IC9		1										
20	C0-02802001	IC10		1										
21	C0-02019001	M51957BFP C61J		1/5/S										
22	C0-02019001	IC11		1/5/S										
23	C0-06557001	IC12		1										
24	C0-02806001	SN74LV14APWR		1/1/P										
25	C0-06557001	IC13		1										
26	C0-06559001	SN74LVC1G04DEVR		1/5/S										
27	C0-06558001	IC14		1										
28	C0-02806001	SN74LV14APWR		1/1/P										
29	C0-06558001	IC15		1										
30	C0-06556001	IC16		1										
31	C0-06556001	IC17		1										
32	C0-06558001	IC18		1										
34	C0-06558001	IC19		1										
35	C0-07988001	IC20		1										
36	C0-02884001	IC21		1										
38	C0-06325000	IC22		1										
39	C0-07987001	IC24		1										
40	C0-05990001	IC25		1										
41	C0-02884001	IC26		1										
42	C0-05990001	IC28		1										
43	C0-08180001	IC29		1										
44	C0-07988001	IC30		1										
45	C0-02883001	IC31		1										
46	C0-02883001	IC32		1										
47	C0-02883001	IC33		1										
48	C0-07854000	IC34		1										
49	C0-06558001	IC35		1										
50	C0-06711000	IC36		1										
51	C0-02884001	IC37		1										
52	C0-06556001	IC38		1										
53	C0-06558001	IC39		1										
		IC40		1										
		IC41		1										
		IC42		1										
		IC43		1										

ITEM NO.	PARTS NO.	PARTS NAME	Q'TY / PAGE	Q'TY / PACK	P	I	R	BSI NO.	TO	T	FROM	SERIAL NO.	REMARKS	C
54	C0-06556001	IC44	1											
55	C0-02884001	IC45	1											
56	C0-06562001	IC46	1											
57	C0-06535000	IC47	1											
58	C0-05776000	IC48	1											
59	C0-07808001	IC49	1											
60	C0-06562001	IC50	1											
61	C0-02676001	SN74LS07DBR	1	5/										
62	C0-06569001	IC51	1											
63	C0-08121001	IC52	1											
64	E0-06671000	CLC1028-0301	1	5/S										
65	C0-05776000	IC54	1											
66	C0-06563001	IC55	1											
67	C0-06569001	IC56	1											
69	C0-02838001	IC57	1											
70	C0-02676001	SN74LS07DBR	1	5/										
311	C0-02806001	SN74LV14APWR	1	1/P										
312	C0-06549001	IC301	1											
315	C0-06556001	IC302	1											
316	C0-06558001	IC305	1											
317	C0-07809000	IC306	1											
318	C0-06556001	IC307	1											
319	C0-06556001	IC308	1											
320	C0-06558001	IC309	1											
321	C0-06557001	IC310	1											
322	C0-06556001	IC311	1											
323	C0-06557001	IC312	1											
324	C0-06848000	IC313	1											
352	C0-08138001	IC314	1											
353	C0-08138001	Q2	1											
354	C0-08138001	Q3	1											
355	C0-08138001	Q4	1											
401	C0-08138001	Q5	1											
402	C0-08138001	Q301	1											
403	C0-08138001	Q302	1											

ITEM NO.	PARTS NO.	PARTS NAME	Q'TY / PAGE	Q'TY / PACK	P	I	R	BSI NO.	TO	T	FROM	SERIAL NO.	REMARKS	C
404	C0-08138001	Q303	1											
451	C0-08125001	Q304	1											
452	C0-08125001	D1	1											
453	C0-08125001	D2	1											
454	C0-08126001	D3	1											
503	C0-08126001	D4	1											
504	C0-08128001	D303	1											
505	C0-08128001	D304	1											
		D305												

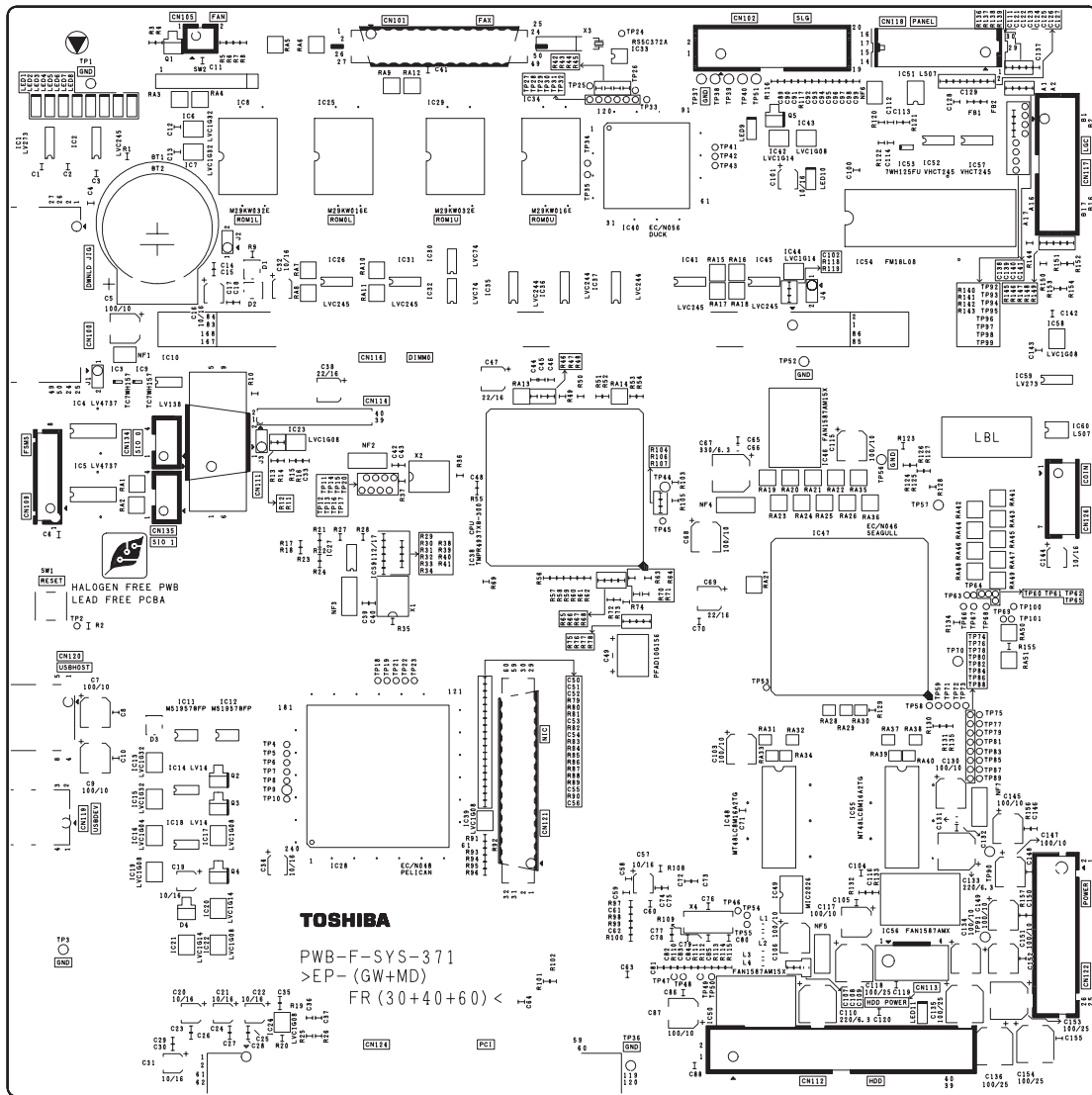

ITEM NO.	PARTS NO.	PARTS NAME	Q'TY / PAGE	Q'TY / PACK	P	I	R	BSI NO.	TO	T	FROM	SERIAL NO.	REMARKS	C
3	D0-07622001	C3	1											
4	D0-07622001	C4	1											
5	D0-16829001	C5	1											
6	D0-07622001	C6	1											
7	D0-16829001	C7	1											
8	D0-07622001	C8	1											
9	D0-16829001	C9	1											
10	D0-07622001	C10	1											
11	D0-07622001	C11	1											
14	D0-07622001	C14	1											
15	D0-07622001	C15	1											
16	D0-16812001	C16	1											
17	D0-07622001	C17	1											
18	D0-07622001	C18	1											
19	D0-16812001	C19	1											
20	D0-16812001	C20	1											
21	D0-16812001	C21	1											
22	D0-16812001	C22	1											
23	D0-07622001	C23	1											
24	D0-07622001	C24	1											
25	D0-07622001	C25	1											
26	D0-07622001	C26	1											
27	D0-07622001	C27	1											
28	D0-07622001	C28	1											
29	D0-07622001	C29	1											
30	D0-07622001	C30	1											
31	D0-16812001	C31	1											
32	D0-16812001	C32	1											
33	D0-04102001	GRM1882C1H101JA01D C33	1	10/P										
34	D0-16812001	C34	1											
35	D0-07622001	C35	1											
36	D0-04093001	GRM1882C1H220JZ01D C36	1	10/P										
37	D0-04093001	GRM1882C1H220JZ01D C37	1	10/P										
38	D0-16813001	C38	1											
41	D0-07622001		1											

ITEM NO.	PARTS NO.	PARTS NAME	Q'TY / PAGE	Q'TY / PACK	P	I	R	BSI NO.	TO	T	FROM	SERIAL NO.	REMARKS	C
42	D0-07622001	C41	1											
43	D0-04102001	GRM1882C1H101JA01D C42	1	10/P										
44	D0-04091001	GRM1882C1H330JZ01D C43	1	10/P										
45	D0-04091001	GRM1882C1H330JZ01D C44	1	10/P										
46	D0-04091001	GRM1882C1H330JZ01D C45	1	10/P										
47	D0-16813001	C46	1											
48	D0-04093001	GRM1882C1H220JZ01D C47	1	10/P										
50	D0-07622001	C48	1											
51	D0-07622001	C50	1											
52	D0-07622001	C51	1											
53	D0-07622001	C52	1											
54	D0-07622001	C53	1											
55	D0-04102001	GRM1882C1H101JA01D C54	1	10/P										
56	D0-07622001	C55	1											
57	D0-16812001	C56	1											
58	D0-07622001	C57	1											
59	D0-07622001	C58	1											
60	D0-04093001	GRM1882C1H220JZ01D C59	1	10/P										
61	D0-07622001	C60	1											
62	D0-07622001	C61	1											
63	D0-07622001	C62	1											
64	D0-07622001	C63	1											
65	D0-07622001	C64	1											
66	D0-05723001	GRM21BF11C105ZA01L C65	1	10/P										
67	D0-16825001	C66	1											
68	D0-16829001	C67	1											
69	D0-16813001	C68	1											
70	D0-07622001	C69	1											
71	D0-07622001	C70	1											
72	D0-07622001	C71	1											
73	D0-07622001	C72	1											
74	D0-07622001	C73	1											
75	D0-07622001	C74	1											
76	D0-07622001	C75	1											
		C76	1											

ITEM NO.	PARTS NO.	PARTS NAME	Q'TY / PAGE	Q'TY / PACK	P	I	R	BSI NO.	TO	T	FROM	SERIAL NO.	REMARKS	C
77	D0-07622001	C77	1											
78	D0-07622001	C78	1											
79	D0-04085001	GRM1882C1H100JZ01D	1	10/P										
80	D0-04093001	GRM1882C1H220JZ01D	1	10/P										
81	D0-07622001	C80	1											
82	D0-07622001	C81	1											
83	D0-04102001	GRM1882C1H101JA01D	1	10/P										
84	D0-07622001	C82	1											
85	D0-07622001	C83	1											
86	D0-07622001	C84	1											
87	D0-07622001	C85	1											
88	D0-07622001	C86	1											
89	D0-16829001	C87	1											
90	D0-07622001	C88	1											
91	D0-07492001	GRM1882C1H331JA01D	1	5/										
92	D0-04102001	GRM1882C1H101JA01D	1	10/P										
93	D0-07492001	GRM1882C1H331JA01D	1	5/										
94	D0-04102001	GRM1882C1H101JA01D	1	10/P										
95	D0-04102001	GRM1882C1H101JA01D	1	10/P										
96	D0-04102001	GRM1882C1H101JA01D	1	10/P										
97	D0-04102001	GRM1882C1H101JA01D	1	10/P										
98	D0-04102001	GRM1882C1H101JA01D	1	10/P										
99	D0-04102001	GRM1882C1H101JA01D	1	10/P										
100	D0-07622001	C90	1											
101	D0-16812001	C91	1											
102	D0-07622001	C92	1											
103	D0-16829001	C93	1											
104	D0-07622001	C94	1											
105	D0-07622001	C95	1											
106	D0-16829001	C96	1											
107	D0-07622001	C97	1											
108	D0-07622001	C98	1											
109	D0-05723001	GRM21BF11C105ZA01L	1	10/P										
110	D0-16824001	C99	1											
111	D0-04102001	GRM1882C1H101JA01D	1	10/P										

ITEM NO.	PARTS NO.	PARTS NAME	Q'TY / PAGE	Q'TY / PACK	P	I	R	BSI NO.	TO	T	FROM	SERIAL NO.	REMARKS	C
112	D0-07622001	C111	1											
113	D0-07622001	C112	1											
114	D0-07622001	C113	1											
115	D0-16829001	C114	1											
117	D0-16829001	C115	1											
118	D0-16835001	C117	1											
119	D0-07622001	C118	1											
120	D0-07622001	C119	1											
121	D0-04102001	GRM1882C1H101JA01D C120	1	10/P										
122	D0-04102001	GRM1882C1H101JA01D C121	1	10/P										
123	D0-04102001	GRM1882C1H101JA01D C122	1	10/P										
124	D0-04102001	GRM1882C1H101JA01D C123	1	10/P										
125	D0-04102001	GRM1882C1H101JA01D C124	1	10/P										
126	D0-04102001	GRM1882C1H101JA01D C125	1	10/P										
127	D0-04102001	GRM1882C1H101JA01D C126	1	10/P										
128	D0-04102001	GRM1882C1H101JA01D C127	1	10/P										
129	D0-04102001	GRM1882C1H101JA01D C128	1	10/P										
130	D0-16829001	C129	1											
131	D0-05723001	GRM21BF11C105ZA01L C130	1	10/P										
132	D0-07622001	C131	1											
133	D0-16824001	C132	1											
134	D0-16829001	C133	1											
135	D0-16835001	C134	1											
136	D0-16835001	C135	1											
137	D0-07622001	C136	1											
138	D0-04093001	GRM1882C1H220JZ01D C137	1	10/P										
139	D0-04093001	GRM1882C1H220JZ01D C138	1	10/P										
140	D0-04093001	GRM1882C1H220JZ01D C139	1	10/P										
141	D0-04093001	GRM1882C1H220JZ01D C140	1	10/P										
142	D0-07622001	C141	1											
143	D0-07622001	C142	1											
144	D0-16812001	C143	1											
145	D0-16829001	C144	1											
146	D0-07622001	C145	1											
		C146	1											

ITEM NO.	PARTS NO.	PARTS NAME	Q'TY / PAGE	Q'TY / PACK	P	I	R	BSI NO.	TO	T	FROM	SERIAL NO.	REMARKS	C
147	D0-16829001		1											
		C147												
148	D0-07622001		1											
		C148												
149	D0-16829001		1											
		C149												
150	D0-07622001		1											
		C150												
151	D0-16829001		1											
		C151												
152	D0-07622001		1											
		C152												
153	D0-16835001		1											
		C153												
154	D0-16835001		1											
		C154												
155	D0-07622001		1											
		C155												
302	D0-07622001		1											
		C302												
303	D0-07622001		1											
		C303												
304	D0-07622001		1											
		C304												
306	D0-07622001		1											
		C306												
307	D0-07622001		1											
		C307												
309	D0-04102001	GRM1882C1H101JA01D	1	10/P										
		C309												
310	D0-04102001	GRM1882C1H101JA01D	1	10/P										
		C310												
311	D0-07622001		1											
		C311												
312	D0-07622001		1											
		C312												
315	D0-07622001		1											
		C315												
317	D0-07622001		1											
		C317												
318	D0-07622001		1											
		C318												
319	D0-07622001		1											
		C319												
320	D0-04102001	GRM1882C1H101JA01D	1	10/P										
		C320												
321	D0-04102001	GRM1882C1H101JA01D	1	10/P										
		C321												
322	D0-07622001		1											
		C322												
323	D0-07622001		1											
		C323												
324	D0-04086001	GRM1882C1H221JA01D	1	10/P										
		C324												
325	D0-07622001		1											
		C325												
326	D0-07622001		1											
		C326												
327	D0-07622001		1											
		C327												
328	D0-07622001		1											
		C328												
329	D0-04101001	GRM188B11H102KA01D	1	10/P										
		C329												
330	D0-07622001		1											
		C330												
331	D0-04101001	GRM188B11H102KA01D	1	10/P										
		C331												
332	D0-07622001		1											

ITEM NO.	PARTS NO.	PARTS NAME	Q'TY / PAGE	Q'TY / PACK	P	I	R	BSI NO.	TO	T	FROM	SERIAL NO.	REMARKS	C
334	D0-04086001	C332 GRM1882C1H221JA01D		1/10/P										
335	D0-04091001	C334 GRM1882C1H330JZ01D		1/10/P										
336	D0-04101001	C335 GRM188B11H102KA01D		1/10/P										
338	D0-07622001	C336		1										
339	D0-07622001	C338		1										
340	D0-07622001	C339		1										
341	D0-04101001	C340 GRM188B11H102KA01D		1/10/P										
342	D0-07622001	C341		1										
343	D0-04101001	C342 GRM188B11H102KA01D		1/10/P										
344	D0-07622001	C343		1										
345	D0-04091001	C344 GRM1882C1H330JZ01D		1/10/P										
346	D0-04091001	C345 GRM1882C1H330JZ01D		1/10/P										
347	D0-04091001	C346 GRM1882C1H330JZ01D		1/10/P										
348	D0-04091001	C347 GRM1882C1H330JZ01D		1/10/P										
349	D0-04091001	C348 GRM1882C1H330JZ01D		1/10/P										
350	D0-07622001	C349		1										
351	D0-04101001	C350 GRM188B11H102KA01D		1/10/P										
352	D0-04101001	C351 GRM188B11H102KA01D		1/10/P										
353	D0-04091001	C352 GRM1882C1H330JZ01D		1/10/P										
354	D0-04091001	C353 GRM1882C1H330JZ01D		1/10/P										
355	D0-07622001	C354		1										
357	D0-07622001	C355		1										
358	D0-07622001	C357		1										
359	D0-07622001	C358		1										
360	D0-07622001	C359		1										
361	D0-07622001	C360		1										
362	D0-07622001	C361		1										
363	D0-07622001	C362		1										
364	D0-07622001	C363		1										
365	D0-07622001	C364		1										
366	D0-07622001	C365		1										
367	D0-07622001	C366		1										
368	D0-04093001	C367 GRM1882C1H220JZ01D		1/10/P										
369	D0-04102001	C368 GRM1882C1H101JA01D		1/10/P										
		C369												

ITEM NO.	PARTS NO.	PARTS NAME	Q'TY / PAGE	Q'TY / PACK	P	I	R	BSI NO.	TO	T	FROM	SERIAL NO.	REMARKS	C
370	D0-07622001	C370	1											
371	D0-07622001	C371	1											
372	D0-04102001	GRM1882C1H101JA01D C372	1	10/P										
373	D0-04102001	GRM1882C1H101JA01D C373	1	10/P										
374	D0-07622001	C374	1											
375	D0-07622001	C375	1											
376	D0-07622001	C376	1											
377	D0-07622001	C377	1											
378	D0-07622001	C378	1											
379	D0-07622001	C379	1											
380	D0-07622001	C380	1											
382	D0-07622001	C382	1											
383	D0-07622001	C383	1											
384	D0-07622001	C384	1											
385	D0-07622001	C385	1											
386	D0-05723001	GRM21BF11C105ZA01L C386	1	10/P										
387	D0-09434001	C387	1											
388	D0-04101001	GRM188B11H102KA01D C388	1	10/P										
389	D0-05723001	GRM21BF11C105ZA01L C389	1	10/P										
390	D0-09434001	C390	1											
391	D0-04101001	GRM188B11H102KA01D C391	1	10/P										
392	D0-04102001	GRM1882C1H101JA01D C392	1	10/P										
393	D0-07622001	C393	1											
394	D0-04101001	GRM188B11H102KA01D C394	1	10/P										
395	D0-07622001	C395	1											
397	D0-04101001	GRM188B11H102KA01D C397	1	10/P										
398	D0-07622001	C398	1											
399	D0-07622001	C399	1											
400	D0-07622001	C400	1											
401	D0-04085001	GRM1882C1H100JZ01D C401	1	10/P										
402	D0-04101001	GRM188B11H102KA01D C402	1	10/P										
403	D0-07622001	C403	1											
404	D0-04093001	GRM1882C1H220JZ01D C404	1	10/P										
405	D0-07622001	C405	1											
406	D0-07622001	C406	1											

ITEM NO.	PARTS NO.	PARTS NAME	Q'TY / PAGE	Q'TY / PACK	P	I	R	B S I NO.	T O	T	F R O M	S E R I A L NO.	R E M A R K S	C
407	D0-07622001	C406	1											
408	D0-07622001	C407	1											
409	D0-07622001	C408	1											
410	D0-07622001	C409	1											
411	D0-07622001	C410	1											
412	D0-07622001	C411	1											
413	D0-07622001	C412	1											
414	D0-07622001	C413	1											
415	D0-07622001	C414	1											
416	D0-07622001	C415	1											
417	D0-07622001	C416	1											
418	D0-07622001	C417	1											
419	D0-04091001	GRM1882C1H330JZ01D C418	1	10/P										
420	D0-04091001	GRM1882C1H330JZ01D C419	1	10/P										
421	D0-04091001	GRM1882C1H330JZ01D C420	1	10/P										
422	D0-07622001	C421	1											
423	D0-07622001	C422	1											
424	D0-04101001	GRM188B11H102KA01D C423	1	10/P										
425	D0-04101001	GRM188B11H102KA01D C424	1	10/P										
426	D0-04091001	GRM1882C1H330JZ01D C425	1	10/P										
427	D0-04101001	GRM188B11H102KA01D C426	1	10/P										
428	D0-07622001	C427	1											
429	D0-04101001	GRM188B11H102KA01D C428	1	10/P										
430	D0-05723001	GRM21BF11C105ZA01L C429	1	10/P										
431	D0-04091001	GRM1882C1H330JZ01D C430	1	10/P										
432	D0-04101001	GRM188B11H102KA01D C431	1	10/P										
433	D0-04091001	GRM1882C1H330JZ01D C432	1	10/P										
434	D0-07622001	C433	1											
435	D0-07622001	C434	1											
436	D0-04091001	GRM1882C1H330JZ01D C435	1	10/P										
437	D0-05723001	GRM21BF11C105ZA01L C436	1	10/P										
438	D0-04101001	GRM188B11H102KA01D C437	1	10/P										
439	D0-09434001	C438	1											
440	D0-04101001	GRM188B11H102KA01D C439	1	10/P										
		C440												

ITEM NO.	PARTS NO.	PARTS NAME	Q'TY / PAGE	Q'TY / PACK	P	I	R	BSI NO.	TO	T	FROM	SERIAL NO.	REMARKS	C
441	D0-07622001	C441	1											
442	D0-07622001	C442	1											
443	D0-07622001	C443	1											
444	D0-04101001	GRM188B11H102KA01D C444	1	10/P										
445	D0-04091001	GRM1882C1H330JZ01D C445	1	10/P										
446	D0-07622001	C446	1											
447	D0-07622001	C447	1											
448	D0-07622001	C448	1											
449	D0-07622001	C449	1											
450	D0-04091001	GRM1882C1H330JZ01D C450	1	10/P										
451	D0-07622001	C451	1											
452	D0-07622001	C452	1											
453	D0-04091001	GRM1882C1H330JZ01D C453	1	10/P										
454	D0-07622001	C454	1											
455	D0-07622001	C455	1											
456	D0-07622001	C456	1											
457	D0-04102001	GRM1882C1H101JA01D C457	1	10/P										
458	D0-07622001	C458	1											
459	D0-07622001	C459	1											
460	D0-07622001	C460	1											
461	D0-04091001	GRM1882C1H330JZ01D C461	1	10/P										
462	D0-04101001	GRM188B11H102KA01D C462	1	10/P										
463	D0-07622001	C463	1											
464	D0-07622001	C464	1											
465	D0-07622001	C465	1											
466	D0-07622001	C466	1											
467	D0-09434001	C467	1											
468	D0-07622001	C468	1											
469	D0-07622001	C469	1											
470	D0-07622001	C470	1											
471	D0-07622001	C471	1											
472	D0-07622001	C472	1											
473	D0-07622001	C473	1											
474	D0-07622001	C474	1											
475	D0-07622001		1											

ITEM NO.	PARTS NO.	PARTS NAME	Q'TY / PAGE	Q'TY / PACK	P	I	R	BSI NO.	TO	T	FROM	SERIAL NO.	REMARKS	C
476	D0-07622001	C475	1											
477	D0-07622001	C476	1											
488	D0-07622001	C477	1											
489	D0-04101001	C488 GRM188B11H102KA01D	1	10/P										
490	D0-07622001	C489	1											
491	D0-04091001	C490 GRM1882C1H330JZ01D	1	10/P										
492	D0-07622001	C491	1											
493	D0-04091001	C492 GRM1882C1H330JZ01D	1	10/P										
494	D0-04101001	C493 GRM188B11H102KA01D	1	10/P										
495	D0-07622001	C494	1											
496	D0-07622001	C495	1											
497	D0-04101001	C496 GRM188B11H102KA01D	1	10/P										
498	D0-04093001	C497 GRM1882C1H220JZ01D	1	10/P										
499	D0-04101001	C498 GRM188B11H102KA01D	1	10/P										
500	D0-07622001	C499	1											
501	D0-04091001	C500 GRM1882C1H330JZ01D	1	10/P										
502	D0-04091001	C501 GRM1882C1H330JZ01D	1	10/P										
503	D0-07622001	C502	1											
504	D0-04101001	C503 GRM188B11H102KA01D	1	10/P										
505	D0-07622001	C504	1											
506	D0-07622001	C505	1											
507	D0-07622001	C506	1											
508	D0-07622001	C507	1											
510	D0-07622001	C508	1											
511	D0-07622001	C510	1											
512	D0-07622001	C511	1											
513	D0-07622001	C512	1											
514	D0-07622001	C513	1											
515	D0-07622001	C514	1											
516	D0-05723001	C515 GRM21BF11C105ZA01L	1	10/P										
517	D0-07622001	C516	1											
518	D0-05723001	C517 GRM21BF11C105ZA01L	1	10/P										
519	D0-07622001	C518	1											
520	D0-07622001	C519	1											
		C520	1											

ITEM NO.	PARTS NO.	PARTS NAME	Q'TY / PAGE	Q'TY / PACK	P	I	R	BSI NO.	TO	T	FROM	SERIAL NO.	REMARKS	C
521	D0-07622001	C521	1											
522	D0-07622001	C522	1											
523	D0-05723001	GRM21BF11C105ZA01L C523	1	10/P										
524	D0-07622001	C524	1											
525	D0-07622001	C525	1											
526	D0-07622001	C526	1											
527	D0-07622001	C527	1											
528	D0-07622001	C528	1											
529	D0-07622001	C529	1											
530	D0-04102001	GRM1882C1H101JA01D C530	1	10/P										
531	D0-07622001	C531	1											
532	D0-05723001	GRM21BF11C105ZA01L C532	1	10/P										
533	D0-07622001	C533	1											
534	D0-07622001	C534	1											
535	D0-07622001	C535	1											
536	D0-07622001	C536	1											
537	D0-07622001	C537	1											
539	D0-07622001	C539	1											
554	D0-07622001	C554	1											
555	D0-07622001	C555	1											
800	D0-04102001	GRM1882C1H101JA01D C1000	1	10/P										

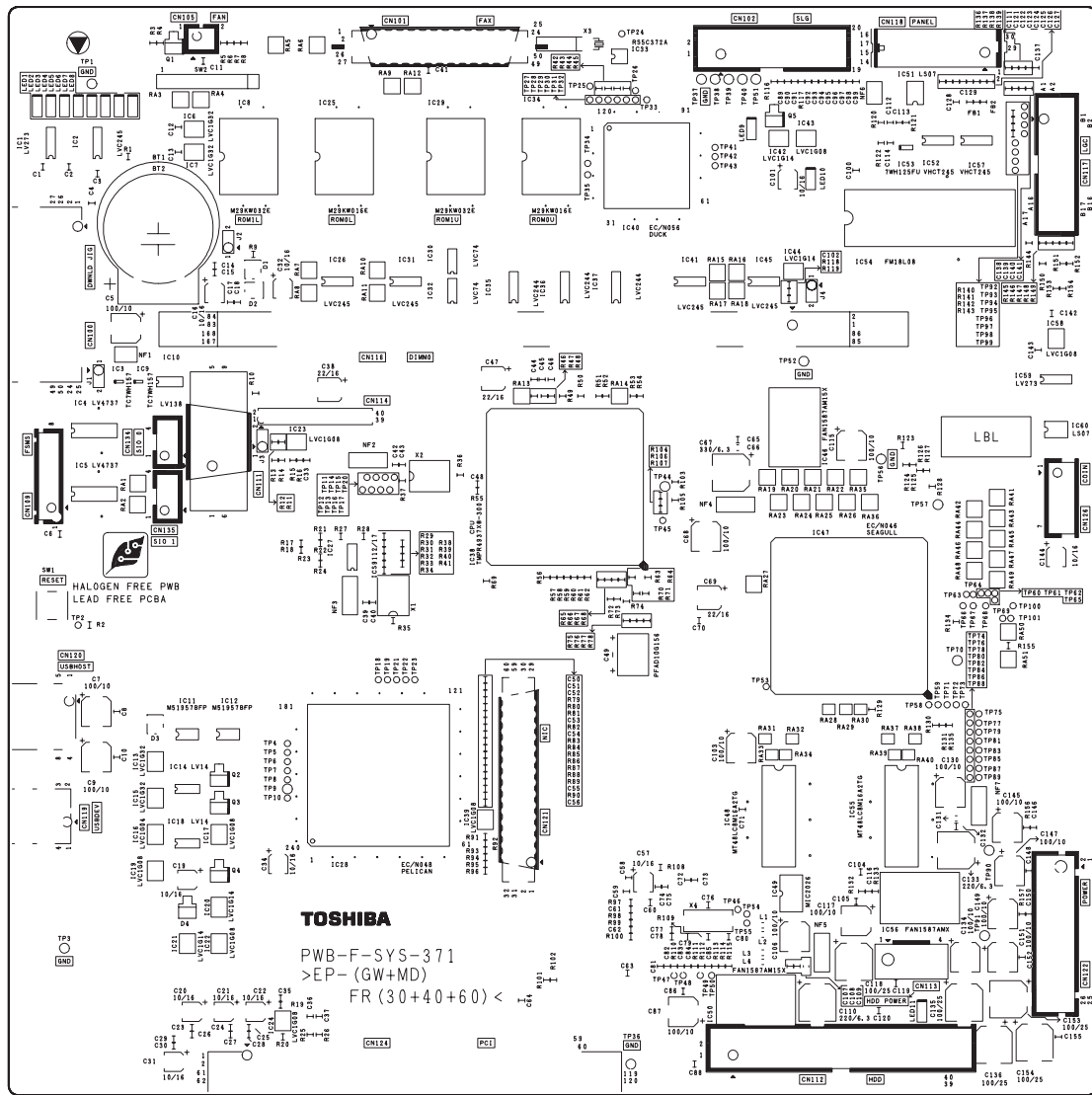

ITEM NO.	PARTS NO.	PARTS NAME	Q'TY / PAGE	Q'TY / PACK	P	I	R	B S I NO.	T O	T	F R O M	S E R I A L NO.	R E M A R K S	C
5	D0-00981001	MCR03EZHZ220		110/P										
		R5												
6	D0-00981001	MCR03EZHZ220		110/P										
		R6												
7	D0-00981001	MCR03EZHZ220		110/P										
		R7												
8	D0-00981001	MCR03EZHZ220		110/P										
		R8												
9	D0-00952001	MCR03EZHZ102		110/P										
		R9												
10	D0-00953001	MCR03EZHZ103		110/P										
		R10												
11	D0-00953001	MCR03EZHZ103		110/P										
		R11												
12	D0-00952001	MCR03EZHZ102		110/P										
		R12												
13	D0-00953001	MCR03EZHZ103		110/P										
		R13												
14	D0-00952001	MCR03EZHZ102		110/P										
		R14												
15	D0-00949001	MCR03EZHZ000		110/P										
		R15												
16	D0-01002001	MCR03EZHZ330		110/P										
		R16												
17	D0-01018001	MCR03EZHZ470		110/P										
		R17												
18	D0-01018001	MCR03EZHZ470		110/P										
		R18												
19	D0-00953001	MCR03EZHZ103		110/P										
		R19												
20	D0-00953001	MCR03EZHZ103		110/P										
		R20												
25	D0-00950001	MCR03EZHZ100		110/P										
		R25												
26	D0-00950001	MCR03EZHZ100		110/P										
		R26												
36	D0-00981001	MCR03EZHZ220		110/P										
		R36												
37	D0-01020001	MCR03EZHZ472		110/P										
		R37												
38	D0-01018001	MCR03EZHZ470		110/P										
		R38												
39	D0-01018001	MCR03EZHZ470		110/P										
		R39												
40	D0-01018001	MCR03EZHZ470		110/P										
		R40												
41	D0-01018001	MCR03EZHZ470		110/P										
		R41												
42	D0-01020001	MCR03EZHZ472		110/P										
		R42												
43	D0-01020001	MCR03EZHZ472		110/P										
		R43												
44	D0-01020001	MCR03EZHZ472		110/P										
		R44												
45	D0-01020001	MCR03EZHZ472		110/P										
		R45												
46	D0-00950001	MCR03EZHZ100		110/P										
		R46												
47	D0-00981001	MCR03EZHZ220		110/P										
		R47												
48	D0-00950001	MCR03EZHZ100		110/P										
		R48												
49	D0-01020001	MCR03EZHZ472		110/P										
		R49												
50	D0-01020001	MCR03EZHZ472		110/P										
		R50												
51	D0-01002001	MCR03EZHZ330		110/P										
		R51												
52	D0-01018001	MCR03EZHZ470		110/P										

ITEM NO.	PARTS NO.	PARTS NAME	Q'TY / PAGE	Q'TY / PACK	PIR	BSI NO.	TO	T	FROM	SERIAL NO.	REMARKS	C
53	D0-01018001	R52 MCR03EZHZJ470		1/10/P								
54	D0-01018001	R53 MCR03EZHZJ470		1/10/P								
55	D0-00950001	R54 MCR03EZHZJ100		1/10/P								
56	D0-01002001	R55 MCR03EZHZJ330		1/10/P								
57	D0-01002001	R56 MCR03EZHZJ330		1/10/P								
58	D0-01002001	R57 MCR03EZHZJ330		1/10/P								
59	D0-01002001	R58 MCR03EZHZJ330		1/10/P								
60	D0-00952001	R59 MCR03EZHZJ102		1/10/P								
61	D0-01002001	R60 MCR03EZHZJ330		1/10/P								
62	D0-00953001	R61 MCR03EZHZJ103		1/10/P								
63	D0-01002001	R62 MCR03EZHZJ330		1/10/P								
64	D0-01002001	R63 MCR03EZHZJ330		1/10/P								
65	D0-01002001	R64 MCR03EZHZJ330		1/10/P								
66	D0-01002001	R65 MCR03EZHZJ330		1/10/P								
67	D0-01002001	R66 MCR03EZHZJ330		1/10/P								
69	D0-00981001	R67 MCR03EZHZJ220		1/10/P								
70	D0-01002001	R69 MCR03EZHZJ330		1/10/P								
72	D0-00953001	R70 MCR03EZHZJ103		1/10/P								
74	D0-01002001	R72 MCR03EZHZJ330		1/10/P								
79	D0-00953001	R74 MCR03EZHZJ103		1/10/P								
80	D0-00953001	R79 MCR03EZHZJ103		1/10/P								
81	D0-01002001	R80 MCR03EZHZJ330		1/10/P								
82	D0-01002001	R81 MCR03EZHZJ330		1/10/P								
83	D0-01002001	R82 MCR03EZHZJ330		1/10/P								
84	D0-01002001	R83 MCR03EZHZJ330		1/10/P								
85	D0-00953001	R84 MCR03EZHZJ103		1/10/P								
86	D0-00953001	R85 MCR03EZHZJ103		1/10/P								
87	D0-01002001	R86 MCR03EZHZJ330		1/10/P								
88	D0-00953001	R87 MCR03EZHZJ103		1/10/P								
89	D0-01002001	R88 MCR03EZHZJ330		1/10/P								
90	D0-01020001	R89 MCR03EZHZJ472		1/10/P								
91	D0-01020001	R90 MCR03EZHZJ472		1/10/P								
92	D0-01002001	R91 MCR03EZHZJ330		1/10/P								
93	D0-01002001	R92 MCR03EZHZJ330		1/10/P								
		R93										

ITEM NO.	PARTS NO.	PARTS NAME	Q'TY / PAGE	Q'TY / PACK	PIR	BSI NO.	TO	T	FROM	SERIAL NO.	REMARKS	C
94	D0-01002001	MCR03EZHJ330 R94		1/10/P								
95	D0-01002001	MCR03EZHJ330 R95		1/10/P								
96	D0-01002001	MCR03EZHJ330 R96		1/10/P								
97	D0-00950001	MCR03EZHJ100 R97		1/10/P								
98	D0-00953001	MCR03EZHJ103 R98		1/10/P								
99	D0-00953001	MCR03EZHJ103 R99		1/10/P								
100	D0-00953001	MCR03EZHJ103 R100		1/10/P								
101	D0-00963001	MCR03EZHJ124 R101		1/5/								
102	D0-01047001	MCR03EZHJ823 R102		1/5/								
103	D0-00953001	MCR03EZHJ103 R103		1/10/P								
104	D0-01002001	MCR03EZHJ330 R104		1/10/P								
107	D0-00951001	MCR03EZHJ101 R107		1/10/P								
108	D0-00951001	MCR03EZHJ101 R108		1/10/P								
110	D0-00953001	MCR03EZHJ103 R110		1/10/P								
112	D0-00953001	MCR03EZHJ103 R112		1/10/P								
113	D0-01020001	MCR03EZHJ472 R113		1/10/P								
114	D0-01020001	MCR03EZHJ472 R114		1/10/P								
115	D0-01020001	MCR03EZHJ472 R115		1/10/P								
116	D0-00953001	MCR03EZHJ103 R116		1/10/P								
117	D0-00951001	MCR03EZHJ101 R117		1/10/P								
119	D0-00949001	MCR03EZHJ000 R119		1/10/P								
120	D0-01004001	MCR03EZHJ332 R120		1/10/P								
121	D0-00953001	MCR03EZHJ103 R121		1/10/P								
122	D0-01020001	MCR03EZHJ472 R122		1/10/P								
123	D0-01020001	MCR03EZHJ472 R123		1/10/P								
124	D0-01020001	MCR03EZHJ472 R124		1/10/P								
125	D0-01020001	MCR03EZHJ472 R125		1/10/P								
126	D0-01020001	MCR03EZHJ472 R126		1/10/P								
127	D0-01020001	MCR03EZHJ472 R127		1/10/P								
128	D0-01020001	MCR03EZHJ472 R128		1/10/P								
129	D0-01002001	MCR03EZHJ330 R129		1/10/P								
130	D0-01020001	MCR03EZHJ472 R130		1/10/P								
131	D0-01020001	MCR03EZHJ472 R131		1/10/P								
132	D0-00951001	MCR03EZHJ101 R132		1/10/P								
133	D0-00951001	MCR03EZHJ101		1/10/P								

ITEM NO.	PARTS NO.	PARTS NAME	Q'TY / PAGE	Q'TY / PACK	PIR	BSI NO.	TO	T	FROM	SERIAL NO.	REMARKS	C
134	D0-01020001	R133 MCR03EZHZJ472		1/10/P								
135	D0-01020001	R134 MCR03EZHZJ472		1/10/P								
136	D0-01004001	R135 MCR03EZHZJ332		1/10/P								
137	D0-01004001	R136 MCR03EZHZJ332		1/10/P								
138	D0-01004001	R137 MCR03EZHZJ332		1/10/P								
139	D0-01004001	R138 MCR03EZHZJ332		1/10/P								
140	D0-00949001	R139 MCR03EZHZJ000		1/10/P								
141	D0-00949001	R140 MCR03EZHZJ000		1/10/P								
142	D0-00949001	R141 MCR03EZHZJ000		1/10/P								
143	D0-00949001	R142 MCR03EZHZJ000		1/10/P								
144	D0-00949001	R143 MCR03EZHZJ000		1/10/P								
145	D0-00953001	R144 MCR03EZHZJ103		1/10/P								
146	D0-00949001	R145 MCR03EZHZJ000		1/10/P								
147	D0-00949001	R146 MCR03EZHZJ000		1/10/P								
148	D0-00952001	R147 MCR03EZHZJ102		1/10/P								
149	D0-00953001	R148 MCR03EZHZJ103		1/10/P								
150	D0-01020001	R149 MCR03EZHZJ472		1/10/P								
151	D0-01020001	R150 MCR03EZHZJ472		1/10/P								
152	D0-01020001	R151 MCR03EZHZJ472		1/10/P								
153	D0-00949001	R152 MCR03EZHZJ000		1/10/P								
154	D0-00953001	R153 MCR03EZHZJ103		1/10/P								
155	D0-00953001	R154 MCR03EZHZJ103		1/10/P								
156	D0-00953001	R155 MCR03EZHZJ103		1/10/P								
157	D0-00953001	R156 MCR03EZHZJ103		1/10/P								
301	D0-00966001	R157 MCR03EZHZJ103		1/10/P								
302	D0-00966001	R301 MCR03EZHZJ152		1/10/P								
303	D0-00966001	R302 MCR03EZHZJ152		1/10/P								
304	D0-00966001	R303 MCR03EZHZJ152		1/10/P								
305	D0-01019001	R304 MCR03EZHZJ152		1/10/P								
306	D0-01019001	R305 MCR03EZHZJ471		1/5/								
307	D0-01019001	R306 MCR03EZHZJ471		1/5/								
308	D0-01019001	R307 MCR03EZHZJ471		1/5/								
309	D0-00981001	R308 MCR03EZHZJ471		1/5/								
310	D0-00981001	R309 MCR03EZHZJ220		1/10/P								
		R310 MCR03EZHZJ220		1/10/P								

ITEM NO.	PARTS NO.	PARTS NAME	Q'TY / PAGE	Q'TY / PACK	P	I	R	B S I NO.	T O	T	F R O M	S E R I A L NO.	R E M A R K S	C
311	D0-00981001	MCR03EZHJ220 R311		1/10/P										
312	D0-00981001	MCR03EZHJ220 R312		1/10/P										
313	D0-00953001	MCR03EZHJ103 R313		1/10/P										
314	D0-00981001	MCR03EZHJ220 R314		1/10/P										
315	D0-00981001	MCR03EZHJ220 R315		1/10/P										
316	D0-00981001	MCR03EZHJ220 R316		1/10/P										
317	D0-00981001	MCR03EZHJ220 R317		1/10/P										
318	D0-00953001	MCR03EZHJ103 R318		1/10/P										
319	D0-00953001	MCR03EZHJ103 R319		1/10/P										
320	D0-00953001	MCR03EZHJ103 R320		1/10/P										
321	D0-01002001	MCR03EZHJ330 R321		1/10/P										
322	D0-01002001	MCR03EZHJ330 R322		1/10/P										
323	D0-00953001	MCR03EZHJ103 R323		1/10/P										
324	D0-00953001	MCR03EZHJ103 R324		1/10/P										
327	D0-01020001	MCR03EZHJ472 R327		1/10/P										
328	D0-01020001	MCR03EZHJ472 R328		1/10/P										
329	D0-01020001	MCR03EZHJ472 R329		1/10/P										
330	D0-01020001	MCR03EZHJ472 R330		1/10/P										
331	D0-01020001	MCR03EZHJ472 R331		1/10/P										
332	D0-01020001	MCR03EZHJ472 R332		1/10/P										
335	D0-00953001	MCR03EZHJ103 R335		1/10/P										
336	D0-00981001	MCR03EZHJ220 R336		1/10/P										
337	D0-00981001	MCR03EZHJ220 R337		1/10/P										
338	D0-01020001	MCR03EZHJ472 R338		1/10/P										
339	D0-01020001	MCR03EZHJ472 R339		1/10/P										
340	D0-00951001	MCR03EZHJ101 R340		1/10/P										
341	D0-00951001	MCR03EZHJ101 R341		1/10/P										
342	D0-00981001	MCR03EZHJ220 R342		1/10/P										
343	D0-00981001	MCR03EZHJ220 R343		1/10/P										
344	D0-01020001	MCR03EZHJ472 R344		1/10/P										
345	D0-01020001	MCR03EZHJ472 R345		1/10/P										
346	D0-01020001	MCR03EZHJ472 R346		1/10/P										
347	D0-01020001	MCR03EZHJ472 R347		1/10/P										
348	D0-01019001	MCR03EZHJ471 R348		1/5/										
349	D0-01002001	MCR03EZHJ330		1/10/P										

ITEM NO.	PARTS NO.	PARTS NAME	Q'TY / PAGE	Q'TY / PACK	PIR	BSI NO.	TO	T	FROM	SERIAL NO.	REMARKS	C
350	D0-01002001	R349 MCR03EZHJ330		1/10/P								
352	D0-00981001	R350 MCR03EZHJ220		1/10/P								
353	D0-00951001	R352 MCR03EZHJ101		1/10/P								
354	D0-01020001	R353 MCR03EZHJ472		1/10/P								
355	D0-01020001	R354 MCR03EZHJ472		1/10/P								
356	D0-01020001	R355 MCR03EZHJ472		1/10/P								
357	D0-01020001	R356 MCR03EZHJ472		1/10/P								
358	D0-01020001	R357 MCR03EZHJ472		1/10/P								
359	D0-01020001	R358 MCR03EZHJ472		1/10/P								
360	D0-01020001	R359 MCR03EZHJ472		1/10/P								
361	D0-01020001	R360 MCR03EZHJ472		1/10/P								
362	D0-01002001	R361 MCR03EZHJ330		1/10/P								
363	D0-01002001	R362 MCR03EZHJ330		1/10/P								
364	D0-00953001	R363 MCR03EZHJ103		1/10/P								
365	D0-00953001	R364 MCR03EZHJ103		1/10/P								
366	D0-00953001	R365 MCR03EZHJ103		1/10/P								
367	D0-01002001	R366 MCR03EZHJ330		1/10/P								
368	D0-00953001	R367 MCR03EZHJ103		1/10/P								
369	D0-01020001	R368 MCR03EZHJ472		1/10/P								
370	D0-01020001	R369 MCR03EZHJ472		1/10/P								
371	D0-01020001	R370 MCR03EZHJ472		1/10/P								
372	D0-01020001	R371 MCR03EZHJ472		1/10/P								
373	D0-01020001	R372 MCR03EZHJ472		1/10/P								
374	D0-01020001	R373 MCR03EZHJ472		1/10/P								
375	D0-01020001	R374 MCR03EZHJ472		1/10/P								
376	D0-01020001	R375 MCR03EZHJ472		1/10/P								
377	D0-01002001	R376 MCR03EZHJ330		1/10/P								
378	D0-00953001	R377 MCR03EZHJ103		1/10/P								
379	D0-00981001	R378 MCR03EZHJ220		1/10/P								
380	D0-01018001	R379 MCR03EZHJ470		1/10/P								
381	D0-01018001	R380 MCR03EZHJ470		1/10/P								
385	D0-01044001	R381 MCR03EZHJ820		1/10/P								
386	D0-00952001	R385 MCR03EZHJ102		1/10/P								
387	D0-00952001	R386 MCR03EZHJ102		1/10/P								
		R387										

ITEM NO.	PARTS NO.	PARTS NAME	Q'TY / PAGE	Q'TY / PACK	P	I	R	B S I NO.	T O	T	F R O M	S E R I A L NO.	R E M A R K S	C
388	D0-00952001	MCR03EZHJ102 R388		1/10/P										
389	D0-00952001	MCR03EZHJ102 R389		1/10/P										
390	D0-00952001	MCR03EZHJ102 R390		1/10/P										
391	D0-00952001	MCR03EZHJ102 R391		1/10/P										
392	D0-00952001	MCR03EZHJ102 R392		1/10/P										
393	D0-00952001	MCR03EZHJ102 R393		1/10/P										
394	D0-00952001	MCR03EZHJ102 R394		1/10/P										
395	D0-00952001	MCR03EZHJ102 R395		1/10/P										
396	D0-00953001	MCR03EZHJ103 R396		1/10/P										
398	D0-00981001	MCR03EZHJ220 R398		1/10/P										
399	D0-00981001	MCR03EZHJ220 R399		1/10/P										
400	D0-00981001	MCR03EZHJ220 R400		1/10/P										
401	D0-00981001	MCR03EZHJ220 R401		1/10/P										
402	D0-00952001	MCR03EZHJ102 R402		1/10/P										
403	D0-00953001	MCR03EZHJ103 R403		1/10/P										
404	D0-01020001	MCR03EZHJ472 R404		1/10/P										
405	D0-00953001	MCR03EZHJ103 R405		1/10/P										
406	D0-01020001	MCR03EZHJ472 R406		1/10/P										
407	D0-00952001	MCR03EZHJ102 R407		1/10/P										
408	D0-01020001	MCR03EZHJ472 R408		1/10/P										
409	D0-01020001	MCR03EZHJ472 R409		1/10/P										
410	D0-01020001	MCR03EZHJ472 R410		1/10/P										
411	D0-01018001	MCR03EZHJ470 R411		1/10/P										
412	D0-01018001	MCR03EZHJ470 R412		1/10/P										
413	D0-01002001	MCR03EZHJ330 R413		1/10/P										
414	D0-00981001	MCR03EZHJ220 R414		1/10/P										
415	D0-01002001	MCR03EZHJ330 R415		1/10/P										
416	D0-00981001	MCR03EZHJ220 R416		1/10/P										
417	D0-01002001	MCR03EZHJ330 R417		1/10/P										
418	D0-01002001	MCR03EZHJ330 R418		1/10/P										
419	D0-01002001	MCR03EZHJ330 R419		1/10/P										
420	D0-01018001	MCR03EZHJ470 R420		1/10/P										
421	D0-01018001	MCR03EZHJ470 R421		1/10/P										
422	D0-00953001	MCR03EZHJ103 R422		1/10/P										
423	D0-00954001	MCR03EZHJ104		1/10/P										

ITEM NO.	PARTS NO.	PARTS NAME	Q'TY / PAGE	Q'TY / PACK	PIR	BSI NO.	TO	T	FROM	SERIAL NO.	REMARKS	C
424	D0-00981001	R423 MCR03EZHJ220		1/10/P								
425	D0-00952001	R424 MCR03EZHJ102		1/10/P								
426	D0-01044001	R425 MCR03EZHJ820		1/10/P								
427	D0-00981001	R426 MCR03EZHJ220		1/10/P								
428	D0-00981001	R427 MCR03EZHJ220		1/10/P								
429	D0-01031001	R428 MCR03EZHJ562		1/5/								
430	D0-01044001	R429 MCR03EZHJ820		1/10/P								
431	D0-00949001	R430 MCR03EZHJ000		1/10/P								
432	D0-00952001	R431 MCR03EZHJ102		1/10/P								
433	D0-01020001	R432 MCR03EZHJ472		1/10/P								
434	D0-01020001	R433 MCR03EZHJ472		1/10/P								
435	D0-00951001	R434 MCR03EZHJ101		1/10/P								
436	D0-00953001	R435 MCR03EZHJ103		1/10/P								
437	D0-00953001	R436 MCR03EZHJ103		1/10/P								
438	D0-01020001	R437 MCR03EZHJ472		1/10/P								
439	D0-01020001	R438 MCR03EZHJ472		1/10/P								
440	D0-01020001	R439 MCR03EZHJ472		1/10/P								
441	D0-01020001	R440 MCR03EZHJ472		1/10/P								
442	D0-01020001	R441 MCR03EZHJ472		1/10/P								
443	D0-01020001	R442 MCR03EZHJ472		1/10/P								
444	D0-01020001	R443 MCR03EZHJ472		1/10/P								
445	D0-01020001	R444 MCR03EZHJ472		1/10/P								
446	D0-00951001	R445 MCR03EZHJ101		1/10/P								
447	D0-00951001	R446 MCR03EZHJ101		1/10/P								
449	D0-01020001	R447 MCR03EZHJ472		1/10/P								
450	D0-01020001	R449 MCR03EZHJ472		1/10/P								
452	D0-01020001	R450 MCR03EZHJ472		1/10/P								
453	D0-00981001	R452 MCR03EZHJ220		1/10/P								
454	D0-00952001	R453 MCR03EZHJ102		1/10/P								
455	D0-00953001	R454 MCR03EZHJ103		1/10/P								
456	D0-00950001	R455 MCR03EZHJ100		1/10/P								
457	D0-01020001	R456 MCR03EZHJ472		1/10/P								
458	D0-01020001	R457 MCR03EZHJ472		1/10/P								
459	D0-00600001	R458 R459		1/								

ITEM NO.	PARTS NO.	PARTS NAME	Q'TY / PAGE	Q'TY / PACK	P	I	R	BSI NO.	TO	T	FROM	SERIAL NO.	REMARKS	C
460	D0-01020001	MCR03EZHJ472 R460		1/10/P										
461	D0-01020001	MCR03EZHJ472 R461		1/10/P										
462	D0-01020001	MCR03EZHJ472 R462		1/10/P										
463	D0-01020001	MCR03EZHJ472 R463		1/10/P										
464	D0-01020001	MCR03EZHJ472 R464		1/10/P										
465	D0-01020001	MCR03EZHJ472 R465		1/10/P										
466	D0-01020001	MCR03EZHJ472 R466		1/10/P										
467	D0-01020001	MCR03EZHJ472 R467		1/10/P										
468	D0-00954001	MCR03EZHJ104 R468		1/10/P										
469	D0-00953001	MCR03EZHJ103 R469		1/10/P										
470	D0-00600001	R470		1										
471	D0-00600001	R471		1										
472	D0-00600001	R472		1										
473	D0-00600001	R473		1										
475	D0-00951001	MCR03EZHJ101 R475		1/10/P										
476	D0-00951001	MCR03EZHJ101 R476		1/10/P										
479	D0-00951001	MCR03EZHJ101 R479		1/10/P										
480	D0-00953001	MCR03EZHJ103 R480		1/10/P										
481	D0-01020001	MCR03EZHJ472 R481		1/10/P										
482	D0-00953001	MCR03EZHJ103 R482		1/10/P										
484	D0-00953001	MCR03EZHJ103 R484		1/10/P										
485	D0-01020001	MCR03EZHJ472 R485		1/10/P										
486	D0-00953001	MCR03EZHJ103 R486		1/10/P										
487	D0-01020001	MCR03EZHJ472 R487		1/10/P										
488	D0-01020001	MCR03EZHJ472 R488		1/10/P										
489	D0-01020001	MCR03EZHJ472 R489		1/10/P										
491	D0-01020001	MCR03EZHJ472 R491		1/10/P										
498	D0-00953001	MCR03EZHJ103 R498		1/10/P										
499	D0-00953001	MCR03EZHJ103 R499		1/10/P										
500	D0-00993001	MCR03EZHJ272 R500		1/5/										
501	D0-01020001	MCR03EZHJ472 R501		1/10/P										
502	D0-01020001	MCR03EZHJ472 R502		1/10/P										
503	D0-01020001	MCR03EZHJ472 R503		1/10/P										
504	D0-01020001	MCR03EZHJ472 R504		1/10/P										
505	D0-01020001	MCR03EZHJ472		1/10/P										

ITEM NO.	PARTS NO.	PARTS NAME	Q'TY / PAGE	Q'TY / PACK	PIR	BSI NO.	TO	T	FROM	SERIAL NO.	REMARKS	C
506	D0-01002001	R505 MCR03EZHZJ330		1/10/P								
507	D0-00953001	R506 MCR03EZHZJ103		1/10/P								
508	D0-00953001	R507 MCR03EZHZJ103		1/10/P								
509	D0-01020001	R508 MCR03EZHZJ472		1/10/P								
512	D0-01020001	R509 MCR03EZHZJ472		1/10/P								
514	D0-00953001	R512 MCR03EZHZJ103		1/10/P								
515	D0-00953001	R514 MCR03EZHZJ103		1/10/P								
516	D0-00953001	R515 MCR03EZHZJ103		1/10/P								
517	D0-01002001	R516 MCR03EZHZJ330		1/10/P								
518	D0-01002001	R517 MCR03EZHZJ330		1/10/P								
519	D0-00953001	R518 MCR03EZHZJ103		1/10/P								
520	D0-00952001	R519 MCR03EZHZJ102		1/10/P								
521	D0-00953001	R520 MCR03EZHZJ103		1/10/P								
522	D0-01031001	R521 MCR03EZHZJ562		1/5/								
523	D0-01020001	R522 MCR03EZHZJ472		1/10/P								
524	D0-00981001	R523 MCR03EZHZJ220		1/10/P								
525	D0-00981001	R524 MCR03EZHZJ220		1/10/P								
526	D0-00981001	R525 MCR03EZHZJ220		1/10/P								
527	D0-00953001	R526 MCR03EZHZJ103		1/10/P								
528	D0-00953001	R527 MCR03EZHZJ103		1/10/P								
530	D0-01020001	R528 MCR03EZHZJ472		1/10/P								
532	D0-01020001	R530 MCR03EZHZJ472		1/10/P								
533	D0-01020001	R532 MCR03EZHZJ472		1/10/P								
536	D0-01020001	R533 MCR03EZHZJ472		1/10/P								
537	D0-01020001	R536 MCR03EZHZJ472		1/10/P								
540	D0-00953001	R537 MCR03EZHZJ103		1/10/P								
541	D0-00953001	R540 MCR03EZHZJ103		1/10/P								
542	D0-00600001	R541		1								
543	D0-00600001	R542		1								
544	D0-01020001	R543 MCR03EZHZJ472		1/10/P								
545	D0-01002001	R544 MCR03EZHZJ330		1/10/P								
546	D0-00953001	R545 MCR03EZHZJ103		1/10/P								
547	D0-01002001	R546 MCR03EZHZJ330		1/10/P								
548	D0-01002001	R547 MCR03EZHZJ330		1/10/P								
		R548										

ITEM NO.	PARTS NO.	PARTS NAME	Q'TY / PAGE	Q'TY / PACK	P	I	R	B S I NO.	T O	T	F R O M	S E R I A L NO.	R E M A R K S	C
549	D0-01002001	MCR03EZHJ330 R549		1/10/P										
550	D0-01002001	MCR03EZHJ330 R550		1/10/P										
551	D0-01002001	MCR03EZHJ330 R551		1/10/P										
552	D0-01002001	MCR03EZHJ330 R552		1/10/P										
553	D0-00953001	MCR03EZHJ103 R553		1/10/P										
554	D0-01002001	MCR03EZHJ330 R554		1/10/P										
555	D0-00953001	MCR03EZHJ103 R555		1/10/P										
556	D0-01002001	MCR03EZHJ330 R556		1/10/P										
557	D0-00993001	MCR03EZHJ272 R557		1/5/										
558	D0-00993001	MCR03EZHJ272 R558		1/5/										
559	D0-00993001	MCR03EZHJ272 R559		1/5/										
560	D0-01002001	MCR03EZHJ330 R560		1/10/P										
561	D0-01002001	MCR03EZHJ330 R561		1/10/P										
562	D0-00981001	MCR03EZHJ220 R562		1/10/P										
563	D0-01002001	MCR03EZHJ330 R563		1/10/P										
564	D0-00993001	MCR03EZHJ272 R564		1/5/										
565	D0-01002001	MCR03EZHJ330 R565		1/10/P										
566	D0-00953001	MCR03EZHJ103 R566		1/10/P										
567	D0-00952001	MCR03EZHJ102 R567		1/10/P										
568	D0-00952001	MCR03EZHJ102 R568		1/10/P										
569	D0-00953001	MCR03EZHJ103 R569		1/10/P										
570	D0-01002001	MCR03EZHJ330 R570		1/10/P										
571	D0-00953001	MCR03EZHJ103 R571		1/10/P										
572	D0-00953001	MCR03EZHJ103 R572		1/10/P										
573	D0-00953001	MCR03EZHJ103 R573		1/10/P										
574	D0-00953001	MCR03EZHJ103 R574		1/10/P										
575	D0-01002001	MCR03EZHJ330 R575		1/10/P										
576	D0-01002001	MCR03EZHJ330 R576		1/10/P										
577	D0-01002001	MCR03EZHJ330 R577		1/10/P										
578	D0-01002001	MCR03EZHJ330 R578		1/10/P										
579	D0-01002001	MCR03EZHJ330 R579		1/10/P										
580	D0-01002001	MCR03EZHJ330 R580		1/10/P										
581	D0-01002001	MCR03EZHJ330 R581		1/10/P										
582	D0-01002001	MCR03EZHJ330 R582		1/10/P										
583	D0-01002001	MCR03EZHJ330		1/10/P										

ITEM NO.	PARTS NO.	PARTS NAME	Q'TY / PAGE	Q'TY / PACK	PIR	BSI NO.	TO	T	FROM	SERIAL NO.	REMARKS	C
584	D0-01002001	R583 MCR03EZHZJ330		1/10/P								
585	D0-01002001	R584 MCR03EZHZJ330		1/10/P								
586	D0-01002001	R585 MCR03EZHZJ330		1/10/P								
587	D0-01002001	R586 MCR03EZHZJ330		1/10/P								
588	D0-01002001	R587 MCR03EZHZJ330		1/10/P								
589	D0-01002001	R588 MCR03EZHZJ330		1/10/P								
590	D0-01002001	R589 MCR03EZHZJ330		1/10/P								
591	D0-01002001	R590 MCR03EZHZJ330		1/10/P								
592	D0-01002001	R591 MCR03EZHZJ330		1/10/P								
593	D0-01002001	R592 MCR03EZHZJ330		1/10/P								
594	D0-01002001	R593 MCR03EZHZJ330		1/10/P								
595	D0-01002001	R594 MCR03EZHZJ330		1/10/P								
596	D0-01002001	R595 MCR03EZHZJ330		1/10/P								
597	D0-01002001	R596 MCR03EZHZJ330		1/10/P								
598	D0-01002001	R597 MCR03EZHZJ330		1/10/P								
599	D0-01002001	R598 MCR03EZHZJ330		1/10/P								
600	D0-01002001	R599 MCR03EZHZJ330		1/10/P								
601	D0-00981001	R600 MCR03EZHZJ220		1/10/P								
603	D0-00981001	R601 MCR03EZHZJ220		1/10/P								
604	D0-00600001	R603		1								
605	D0-00981001	R604 MCR03EZHZJ220		1/10/P								
606	D0-00981001	R605 MCR03EZHZJ220		1/10/P								
607	D0-00981001	R606 MCR03EZHZJ220		1/10/P								
608	D0-00981001	R607 MCR03EZHZJ220		1/10/P								
609	D0-00981001	R608 MCR03EZHZJ220		1/10/P								
610	D0-00993001	R609 MCR03EZHZJ272		1/5/								
611	D0-00981001	R610 MCR03EZHZJ220		1/10/P								
612	D0-00993001	R611 MCR03EZHZJ272		1/5/								
613	D0-00993001	R612 MCR03EZHZJ272		1/5/								
614	D0-00981001	R613 MCR03EZHZJ220		1/10/P								
615	D0-00993001	R614 MCR03EZHZJ272		1/5/								
616	D0-00993001	R615 MCR03EZHZJ272		1/5/								
617	D0-00981001	R616 MCR03EZHZJ220		1/10/P								
618	D0-00981001	R617 MCR03EZHZJ220		1/10/P								
		R618										

ITEM NO.	PARTS NO.	PARTS NAME	Q'TY / PAGE	Q'TY / PACK	P	I	R	BSI NO.	TO	T	FROM	SERIAL NO.	REMARKS	C
620	D0-00981001	MCR03EZHJ220 R620		1/10/P										
622	D0-00600001	R622		1										
623	D0-00981001	MCR03EZHJ220 R623		1/10/P										
626	D0-00981001	MCR03EZHJ220 R626		1/10/P										
627	D0-01020001	MCR03EZHJ472 R627		1/10/P										
628	D0-01020001	MCR03EZHJ472 R628		1/10/P										
629	D0-01020001	MCR03EZHJ472 R629		1/10/P										
631	D0-00993001	MCR03EZHJ272 R631		1/5/										
632	D0-00993001	MCR03EZHJ272 R632		1/5/										
633	D0-00993001	MCR03EZHJ272 R633		1/5/										
634	D0-00993001	MCR03EZHJ272 R634		1/5/										
635	D0-00993001	MCR03EZHJ272 R635		1/5/										
636	D0-00949001	MCR03EZHJ000 R636		1/10/P										
637	D0-01020001	MCR03EZHJ472 R637		1/10/P										
638	D0-01020001	MCR03EZHJ472 R638		1/10/P										
639	D0-01020001	MCR03EZHJ472 R639		1/10/P										
640	D0-01020001	MCR03EZHJ472 R640		1/10/P										
641	D0-01020001	MCR03EZHJ472 R641		1/10/P										
642	D0-01020001	MCR03EZHJ472 R642		1/10/P										
643	D0-01020001	MCR03EZHJ472 R643		1/10/P										
644	D0-01020001	MCR03EZHJ472 R644		1/10/P										
645	D0-01020001	MCR03EZHJ472 R645		1/10/P										
646	D0-01020001	MCR03EZHJ472 R646		1/10/P										
647	D0-01020001	MCR03EZHJ472 R647		1/10/P										
648	D0-01020001	MCR03EZHJ472 R648		1/10/P										
649	D0-01020001	MCR03EZHJ472 R649		1/10/P										
650	D0-00950001	MCR03EZHJ100 R650		1/10/P										
651	D0-01027001	MCR03EZHJ512 R651		1/10/P										
652	D0-00984001	MCR03EZHJ223 R652		1/10/P										
653	D0-00949001	MCR03EZHJ000 R653		1/10/P										
654	D0-00953001	MCR03EZHJ103 R654		1/10/P										
655	D0-00951001	MCR03EZHJ101 R655		1/10/P										
656	D0-01020001	MCR03EZHJ472 R656		1/10/P										
664	D0-01002001	MCR03EZHJ330 R664		1/10/P										
665	D0-01002001	MCR03EZHJ330		1/10/P										

ITEM NO.	PARTS NO.	PARTS NAME	Q'TY / PAGE	Q'TY / PACK	P I R	B S I NO.	T O	T	F R O M	S E R I A L NO.	R E M A R K S	C
666	D0-01134001	R665	1									
667	D0-01053001	R666 MCR03EZPF1002	1	10/P								
668	D0-01149001	R667 MCR03EZPF4701	1	5/								
669	D0-01134001	R668	1									
670	D0-00953001	R669 MCR03EZHZ103	1	10/P								
671	D0-00952001	R670 MCR03EZHZ102	1	10/P								
672	D0-00952001	R671 MCR03EZHZ102	1	10/P								
673	D0-00953001	R672 MCR03EZHZ103	1	10/P								
674	D0-00952001	R673 MCR03EZHZ102	1	10/P								
675	D0-00952001	R674 MCR03EZHZ102	1	10/P								
676	D0-01020001	R675 MCR03EZHZ472	1	10/P								
677	D0-01021001	R676 MCR03EZHZ473	1	10/P								
678	D0-00952001	R677 MCR03EZHZ102	1	10/P								
679	D0-01021001	R678 MCR03EZHZ473	1	10/P								
680	D0-01020001	R679 MCR03EZHZ472	1	10/P								
681	D0-00953001	R680 MCR03EZHZ103	1	10/P								
682	D0-00953001	R681 MCR03EZHZ103	1	10/P								
683	D0-01020001	R682 MCR03EZHZ472	1	10/P								
684	D0-00952001	R683 MCR03EZHZ102	1	10/P								
693	D0-00953001	R684 MCR03EZHZ103	1	10/P								
694	D0-00981001	R693 MCR03EZHZ220	1	10/P								
695	D0-00952001	R694 MCR03EZHZ102	1	10/P								
696	D0-00949001	R695 MCR03EZHZ000	1	10/P								
697	D0-00981001	R696 MCR03EZHZ220	1	10/P								
698	D0-00967001	R697 MCR03EZHZ153	1	5/								
699	D0-01672001	R698	1									
700	D0-01672001	R699	1									
701	D0-00967001	R700 MCR03EZHZ153	1	5/								
702	D0-00967001	R701 MCR03EZHZ153	1	5/								
703	D0-01672001	R702	1									
704	D0-01672001	R703	1									
705	D0-00967001	R704 MCR03EZHZ153	1	5/								
706	D0-05827001	R705	1									
707	D0-05827001	R706	1									
		R707										

ITEM NO.	PARTS NO.	PARTS NAME	Q'TY / PAGE	Q'TY / PACK	P	I	R	BSI NO.	TO	T	FROM	SERIAL NO.	REMARKS	C
708	D0-00966001	MCR03EZHJ152 R708	1	10/P										
750	E0-06438000	CN100	1											
751	E0-00068000	DHB-PB50-S13NN CN101	1	5/										
752	E0-06559000	CN102	1											
762	E0-06675000	CN112	1											
763	E0-00780000	CN113	1											
766	E0-06446000	CN116	1											
767	E0-01712000	CN117	1											
768	E0-06910000	CN118	1											
769	E0-07201000	CN119	1											
770	E0-07052000	CN120	1											
771	E0-00077000	DHB-RD60-S131N-4.9 CN121	1	5/										
772	E0-01547000	DF1B-26DP-2.5DSA CN122	1	5/P										
774	E0-06978000	CN124	1											
776	E0-06856000	CN126	1											
784	E0-06789000	CN134	1											
802	E0-04239000	J2	1											
852	E0-04340000	CR2450-HE4 BT2	1	1/C										

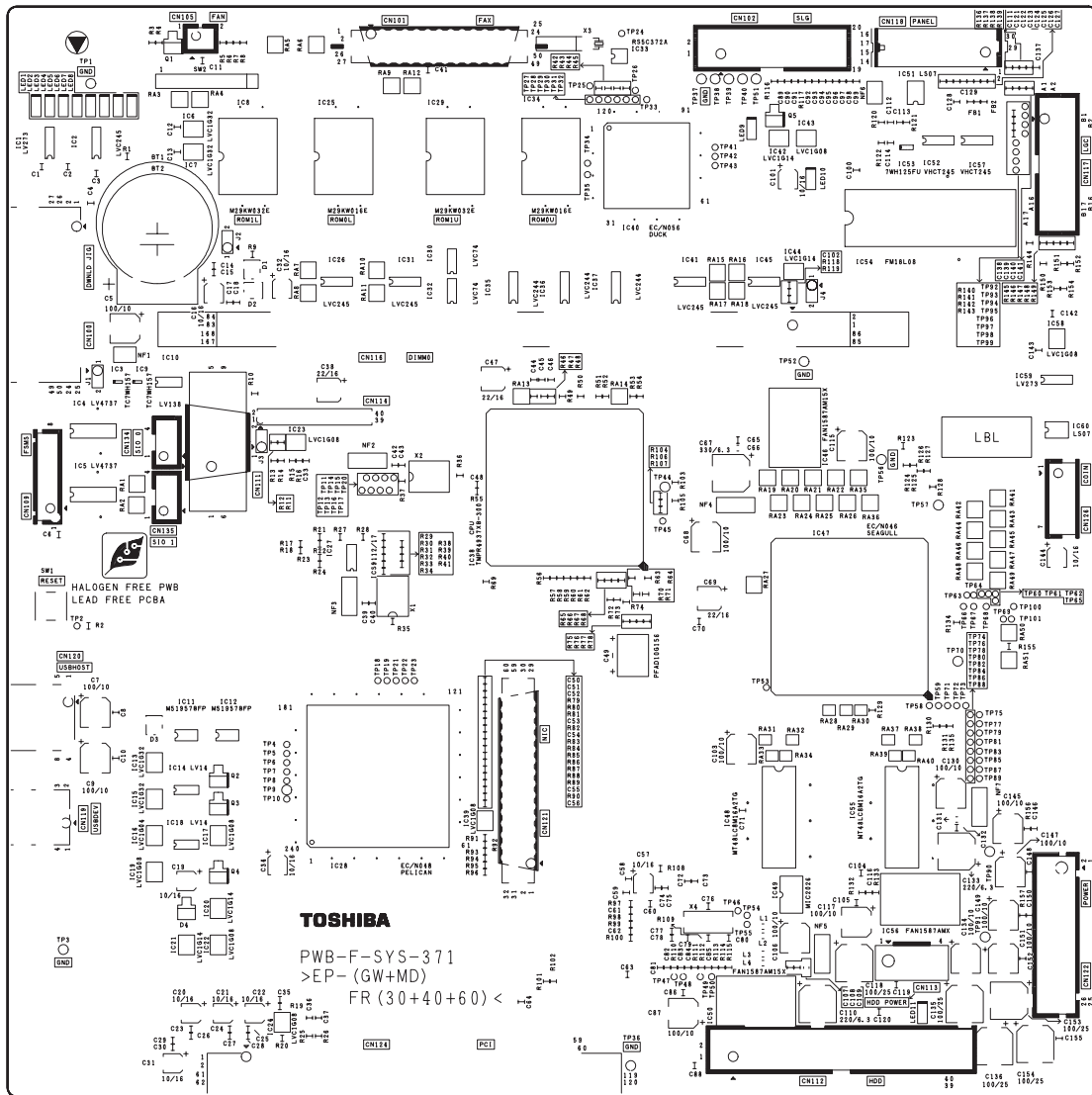

ITEM NO.	PARTS NO.	PARTS NAME	Q'TY / PAGE	Q'TY / PACK	P	I	R	BSI NO.	TO	T	FROM	SERIAL NO.	REMARKS	C
1	D0-04445001		1											
		FB1												
2	D0-04445001		1											
		FB2												
301	D0-04445001		1											
		FB301												
302	D0-04445001		1											
		FB302												
303	D0-07755001		1											
		FB303												
304	D0-07755001		1											
		FB304												
351	D0-15881001		1											
		L1												
352	D0-15881001		1											
		L2												
353	D0-15881001		1											
		L3												
354	D0-15881001		1											
		L4												
651	D0-15881001		1											
		L301												
652	D0-15881001		1											
		L302												
653	D0-15881001		1											
		L303												
654	D0-15881001		1											
		L304												
655	D0-15881001		1											
		L305												
711	C0-00379001		1											
		LED11												
751	D0-05475001		1											
		NF1												
752	D0-05478001	NFE61PT472C1H9L	15/											
		NF2												
754	D0-05478001	NFE61PT472C1H9L	15/											
		NF4												
755	D0-05478001	NFE61PT472C1H9L	15/											
		NF5												
756	D0-05475001		1											
		NF6												
757	D0-05478001	NFE61PT472C1H9L	15/											
		NF7												

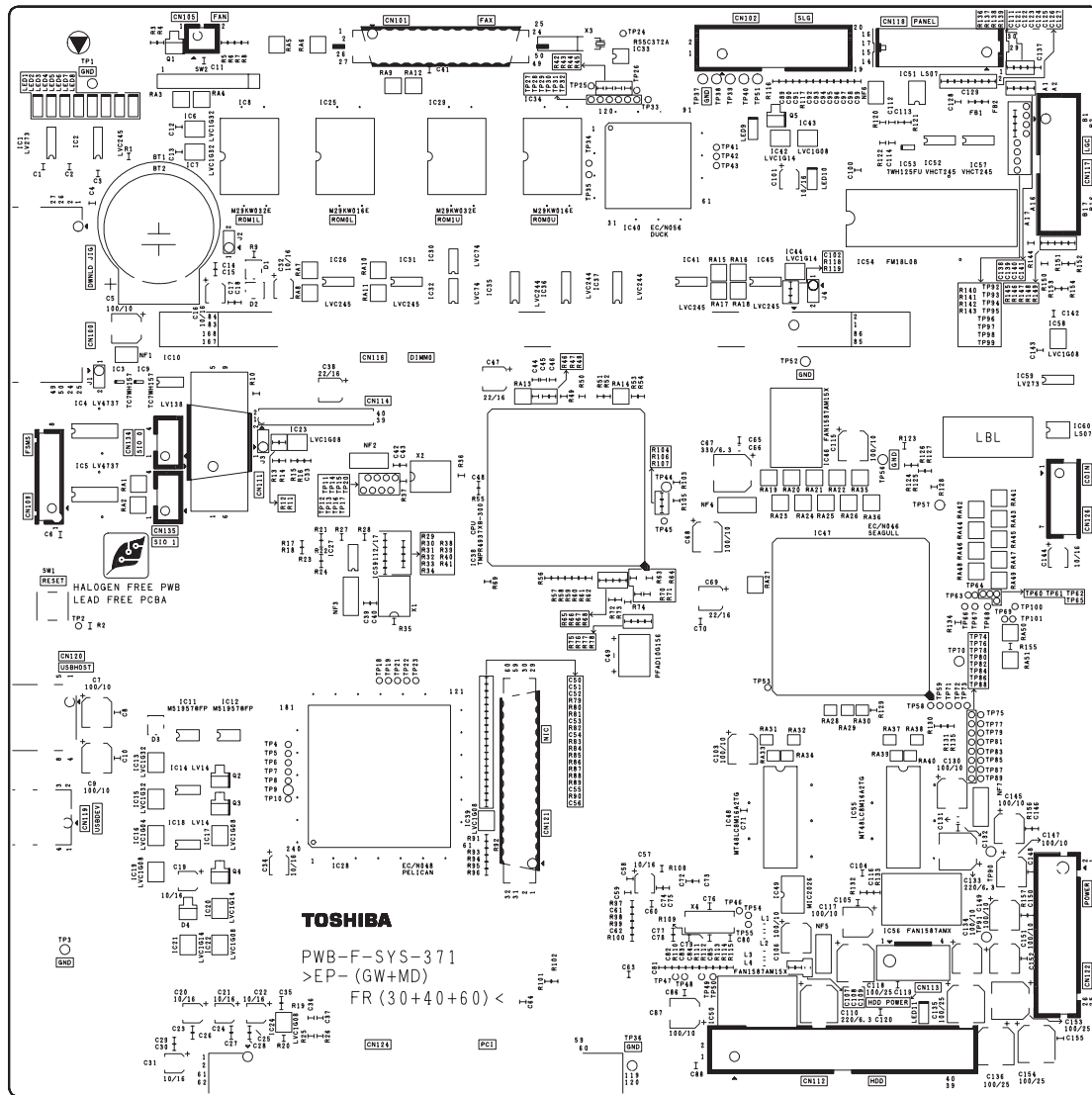

ITEM NO.	PARTS NO.	PARTS NAME	Q'TY / PAGE	Q'TY / PACK	P	I	R	B S I NO.	T O	T	F R O M	S E R I A L NO.	R E M A R K S	C
2	D0-01201001	MNR14E0ABJ103 RA2	1	5/										
5	D0-05419001	MNR14E0ABJ220 RA5	1	5/										
6	D0-05419001	MNR14E0ABJ220 RA6	1	5/										
7	D0-01217001	MNR14E0ABJ472 RA7	1	5/										
8	D0-01217001	MNR14E0ABJ472 RA8	1	5/										
9	D0-01201001	MNR14E0ABJ103 RA9	1	5/										
10	D0-01217001	MNR14E0ABJ472 RA10	1	5/										
11	D0-01217001	MNR14E0ABJ472 RA11	1	5/										
12	D0-01201001	MNR14E0ABJ103 RA12	1	5/										
13	D0-01222001	RA13	1											
14	D0-01222001	RA14	1											
15	D0-01217001	MNR14E0ABJ472 RA15	1	5/										
16	D0-01217001	MNR14E0ABJ472 RA16	1	5/										
17	D0-01217001	MNR14E0ABJ472 RA17	1	5/										
18	D0-01217001	MNR14E0ABJ472 RA18	1	5/										
19	D0-01217001	MNR14E0ABJ472 RA19	1	5/										
20	D0-01217001	MNR14E0ABJ472 RA20	1	5/										
21	D0-01217001	MNR14E0ABJ472 RA21	1	5/										
22	D0-01217001	MNR14E0ABJ472 RA22	1	5/										
23	D0-01217001	MNR14E0ABJ472 RA23	1	5/										
24	D0-01217001	MNR14E0ABJ472 RA24	1	5/										
25	D0-01217001	MNR14E0ABJ472 RA25	1	5/										
26	D0-01217001	MNR14E0ABJ472 RA26	1	5/										
27	D0-01201001	MNR14E0ABJ103 RA27	1	5/										
28	D0-01194001	RA28	1											
29	D0-01194001	RA29	1											
30	D0-01194001	RA30	1											
31	D0-01196001	RA31	1											
32	D0-01196001	RA32	1											
33	D0-01196001	RA33	1											
34	D0-01196001	RA34	1											
35	D0-01217001	MNR14E0ABJ472 RA35	1	5/										
36	D0-01217001	MNR14E0ABJ472 RA36	1	5/										
37	D0-01196001	RA37	1											
38	D0-01196001		1											

ITEM NO.	PARTS NO.	PARTS NAME	Q'TY / PAGE	Q'TY / PACK	P	I	R	B S I NO.	T O	T	F R O M	S E R I A L NO.	R E M A R K S	C
39	D0-01196001	RA38	1											
40	D0-01196001	RA39	1											
41	D0-01201001	RA40 MNR14E0ABJ103	1	15/										
42	D0-01201001	RA41 MNR14E0ABJ103	1	15/										
43	D0-01201001	RA42 MNR14E0ABJ103	1	15/										
44	D0-01201001	RA43 MNR14E0ABJ103	1	15/										
45	D0-01201001	RA44 MNR14E0ABJ103	1	15/										
46	D0-01201001	RA45 MNR14E0ABJ103	1	15/										
47	D0-01201001	RA46 MNR14E0ABJ103	1	15/										
48	D0-01201001	RA47 MNR14E0ABJ103	1	15/										
49	D0-01201001	RA48 MNR14E0ABJ103	1	15/										
50	D0-01201001	RA49 MNR14E0ABJ103	1	15/										
51	D0-01201001	RA50 MNR14E0ABJ103	1	15/										
301	D0-08728001	RA51	1											
302	D0-08728001	RA301	1											
303	D0-05419001	RA302 MNR14E0ABJ220	1	15/										
304	D0-01217001	RA303 MNR14E0ABJ472	1	15/										
305	D0-01217001	RA304 MNR14E0ABJ472	1	15/										
306	D0-01217001	RA305 MNR14E0ABJ472	1	15/										
307	D0-01217001	RA306 MNR14E0ABJ472	1	15/										
308	D0-01194001	RA307	1											
309	D0-01194001	RA308	1											
310	D0-01194001	RA309	1											
311	D0-01194001	RA310	1											
312	D0-01201001	RA311 MNR14E0ABJ103	1	15/										
313	D0-05419001	RA312 MNR14E0ABJ220	1	15/										
314	D0-05419001	RA313 MNR14E0ABJ220	1	15/										
315	D0-01201001	RA314 MNR14E0ABJ103	1	15/										
316	D0-01201001	RA315 MNR14E0ABJ103	1	15/										
317	D0-01201001	RA316 MNR14E0ABJ103	1	15/										
318	D0-01217001	RA317 MNR14E0ABJ472	1	15/										
319	D0-01217001	RA318 MNR14E0ABJ472	1	15/										
320	D0-01201001	RA319 MNR14E0ABJ103	1	15/										
321	D0-01201001	RA320 MNR14E0ABJ103	1	15/										
		RA321												

ITEM NO.	PARTS NO.	PARTS NAME	Q'TY / PAGE	Q'TY / PACK	P	I	R	B S I NO.	T O	T	F R O M	S E R I A L NO.	R E M A R K S	C
352	D0-18790001	X2	1											
353	D0-07067000	MX-38T-32.768KHZ-5PPM X3	1	1/C										
354	D0-15882001	X4	1											
401	E0-03359000	IMSA-9206H-GF JP1	1	5/P										

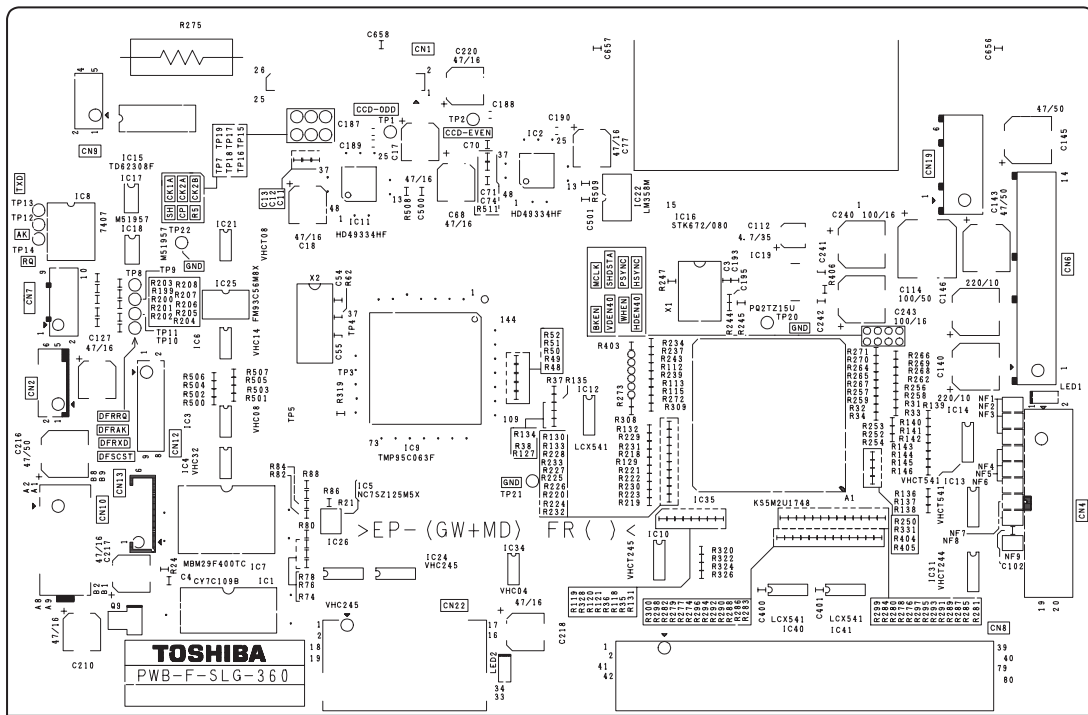

ITEM NO.	PARTS NO.	PARTS NAME	Q'TY / PAGE	Q'TY / PACK	P	I	R	BSI NO.	TO	T	FROM	SERIAL NO.	REMARKS	C
0	6LA89808000	ASY-SLG-371S		11/P										
11	C0-05984001			1										
12	C0-06856000	IC1		1										
13	C0-01937001	IC2		11/S										
14	C0-01946001	74VHC08MTCX IC3		11/S										
15	C0-01990001	74VHC32MTCX IC4		11/S										
16	C0-01941001	NC7SZ125M5X IC5		11/S										
17	C0-02029000	74VHC14MTCX IC6		11/S										
18	C0-01957001	MBM29F400TC-90PFTN IC7		15/S										
19	C0-06762000	DM7407MX IC8		11/S										
20	C0-06569001	EC-N062 TMP95C063FE IC9		1										
21	C0-06856000	IC10		1										
23	C0-06889001	IC11		1										
24	C0-06889001	IC13		1										
26	C0-06838000	IC14		1										
27	C0-02019001	IC16		15/S										
29	C0-02005001	M51957BFP C61J IC17		11/S										
31	C0-06444001	PQ2TZ15U IC19		1										
32	C0-01902001	IC21		15/S										
34	C0-04597001	LM358MX IC22		15/S										
36	C0-04597001	74VHC245MTCX IC24		15/S										
41	C0-01951001	74VHC245MTCX IC26		1										
44	C0-01935001	IC31		11/S										
45	C0-06999000	74VHC04MTCX IC34		1										
102	C0-00657001	IC35		15/P										
104	C0-00675001	RN1401 (TE85R) Q2		1										
105	C0-00657001	Q4		15/P										
106	C0-00657001	RN1401 (TE85R) Q5		15/P										
107	C0-00517002	RN1401 (TE85R) Q6		1										
151	C0-00470001	Q7		15/										
152	C0-00470001	1SS184 (TE85L) D1		15/										
153	C0-00473001	1SS184 (TE85L) D2		15/P										
201	C0-00426001	1SS193 (TE85R) D3		15/P										
251	D0-04100001	02CZ3.3-X (TE85R) ZD1		110/P										
252	D0-04098001	GRM188B11H103KA01D C1		110/P										
		GRM188F11E104ZA01D C2												

ITEM NO.	PARTS NO.	PARTS NAME	Q'TY / PAGE	Q'TY / PACK	PIR	BSI NO.	TO	T	FROM	SERIAL NO.	REMARKS	C
253	D0-04090001	GRM1882C1H471JA01D C3		1/10/P								
256	D0-04092001	GRM188B11H222KA01D C6		1/10/P								
257	D0-04098001	GRM188F11E104ZA01D C7		1/10/P								
258	D0-04098001	GRM188F11E104ZA01D C8		1/10/P								
259	D0-04098001	GRM188F11E104ZA01D C9		1/10/P								
261	D0-04098001	GRM188F11E104ZA01D C11		1/10/P								
262	D0-04098001	GRM188F11E104ZA01D C12		1/10/P								
263	D0-04098001	GRM188F11E104ZA01D C13		1/10/P								
264	D0-04098001	GRM188F11E104ZA01D C14		1/10/P								
265	D0-04098001	GRM188F11E104ZA01D C15		1/10/P								
266	D0-04087001	GRM1882C1E821JA01D C16		1/5/P								
267	D0-15995001	C17		1								
268	D0-15995001	C18		1								
294	D0-04098001	GRM188F11E104ZA01D C44		1/10/P								
295	D0-04098001	GRM188F11E104ZA01D C45		1/10/P								
296	D0-04098001	GRM188F11E104ZA01D C46		1/10/P								
297	D0-04098001	GRM188F11E104ZA01D C47		1/10/P								
298	D0-04098001	GRM188F11E104ZA01D C48		1/10/P								
299	D0-04098001	GRM188F11E104ZA01D C49		1/10/P								
300	D0-04098001	GRM188F11E104ZA01D C50		1/10/P								
301	D0-04098001	GRM188F11E104ZA01D C51		1/10/P								
302	D0-04098001	GRM188F11E104ZA01D C52		1/10/P								
303	D0-04098001	GRM188F11E104ZA01D C53		1/10/P								
304	D0-04085001	GRM1882C1H100JZ01D C54		1/10/P								
305	D0-04085001	GRM1882C1H100JZ01D C55		1/10/P								
307	D0-04098001	GRM188F11E104ZA01D C57		1/10/P								
308	D0-04098001	GRM188F11E104ZA01D C58		1/10/P								
309	D0-04098001	GRM188F11E104ZA01D C59		1/10/P								
310	D0-04098001	GRM188F11E104ZA01D C60		1/10/P								
313	D0-04098001	GRM188F11E104ZA01D C63		1/10/P								
314	D0-04098001	GRM188F11E104ZA01D C64		1/10/P								
315	D0-04098001	GRM188F11E104ZA01D C65		1/10/P								
316	D0-04098001	GRM188F11E104ZA01D C66		1/10/P								
317	D0-04098001	GRM188F11E104ZA01D C67		1/10/P								
318	D0-15995001			1								

ITEM NO.	PARTS NO.	PARTS NAME	Q'TY / PAGE	Q'TY / PACK	PIR	BSI NO.	TO	T	FROM	SERIAL NO.	REMARKS	C
319	D0-04087001	C68 GRM1882C1E821JA01D		1/5/P								
320	D0-04098001	C69 GRM188F11E104ZA01D		1/10/P								
321	D0-04098001	C70 GRM188F11E104ZA01D		1/10/P								
322	D0-05723001	C71 GRM21BF11C105ZA01L		1/10/P								
323	D0-05723001	C72 GRM21BF11C105ZA01L		1/10/P								
324	D0-04098001	C73 GRM188F11E104ZA01D		1/10/P								
325	D0-04098001	C74 GRM188F11E104ZA01D		1/10/P								
326	D0-04098001	C75 GRM188F11E104ZA01D		1/10/P								
327	D0-15995001	C76 GRM188F11E104ZA01D		1/								
328	D0-04098001	C77 GRM188F11E104ZA01D		1/10/P								
330	D0-04102001	C78 GRM1882C1H101JA01D		1/10/P								
331	D0-04093001	C80 GRM1882C1H220JZ01D		1/10/P								
332	D0-04102001	C81 GRM1882C1H101JA01D		1/10/P								
333	D0-04093001	C82 GRM1882C1H220JZ01D		1/10/P								
334	D0-04093001	C83 GRM1882C1H220JZ01D		1/10/P								
335	D0-04093001	C84 GRM1882C1H220JZ01D		1/10/P								
336	D0-04093001	C85 GRM1882C1H220JZ01D		1/10/P								
337	D0-04093001	C86 GRM1882C1H220JZ01D		1/10/P								
338	D0-04093001	C87 GRM1882C1H220JZ01D		1/10/P								
339	D0-04093001	C88 GRM1882C1H220JZ01D		1/10/P								
340	D0-04093001	C89 GRM1882C1H220JZ01D		1/10/P								
341	D0-04093001	C90 GRM1882C1H220JZ01D		1/10/P								
342	D0-04093001	C91 GRM1882C1H220JZ01D		1/10/P								
345	D0-04099001	C92 GRM188F11C104ZA01D		1/10/P								
346	D0-04099001	C95 GRM188F11C104ZA01D		1/10/P								
347	D0-04099001	C96 GRM188F11C104ZA01D		1/10/P								
348	D0-04099001	C97 GRM188F11C104ZA01D		1/10/P								
349	D0-04099001	C98 GRM188F11C104ZA01D		1/10/P								
350	D0-04099001	C99 GRM188F11C104ZA01D		1/10/P								
351	D0-04099001	C100 GRM188F11C104ZA01D		1/10/P								
352	D0-04102001	C101 GRM1882C1H101JA01D		1/10/P								
353	D0-04099001	C102 GRM188F11C104ZA01D		1/10/P								
354	D0-04102001	C103 GRM1882C1H101JA01D		1/10/P								
355	D0-04099001	C104 GRM188F11C104ZA01D		1/10/P								
		C105										

ITEM NO.	PARTS NO.	PARTS NAME	Q'TY / PAGE	Q'TY / PACK	PIR	BSI NO.	TO	T	FROM	SERIAL NO.	REMARKS	C
356	D0-04098001	GRM188F11E104ZA01D C106		1/10/P								
357	D0-04098001	GRM188F11E104ZA01D C107		1/10/P								
358	D0-04101001	GRM188B11H102KA01D C108		1/10/P								
359	D0-04092001	GRM188B11H222KA01D C109		1/10/P								
360	D0-04042001	C1608JF1H104ZT C110		1/10/P								
361	D0-04042001	C1608JF1H104ZT C111		1/10/P								
362	D0-15999001	C112		1								
363	D0-04042001	C1608JF1H104ZT C113		1/10/P								
364	D0-16003001	C114		1								
365	D0-04098001	GRM188F11E104ZA01D C115		1/10/P								
367	D0-04098001	GRM188F11E104ZA01D C117		1/10/P								
369	D0-04100001	GRM188B11H103KA01D C119		1/10/P								
370	D0-04099001	GRM188F11C104ZA01D C120		1/10/P								
371	D0-04098001	GRM188F11E104ZA01D C121		1/10/P								
372	D0-04099001	GRM188F11C104ZA01D C122		1/10/P								
373	D0-04098001	GRM188F11E104ZA01D C123		1/10/P								
375	D0-04098001	GRM188F11E104ZA01D C125		1/10/P								
376	D0-04099001	GRM188F11C104ZA01D C126		1/10/P								
377	D0-15995001	C127		1								
378	D0-04098001	GRM188F11E104ZA01D C128		1/10/P								
379	D0-04099001	GRM188F11C104ZA01D C129		1/10/P								
380	D0-04099001	GRM188F11C104ZA01D C130		1/10/P								
381	D0-04099001	GRM188F11C104ZA01D C131		1/10/P								
382	D0-04102001	GRM1882C1H101JA01D C132		1/10/P								
383	D0-04102001	GRM1882C1H101JA01D C133		1/10/P								
384	D0-04102001	GRM1882C1H101JA01D C134		1/10/P								
385	D0-04102001	GRM1882C1H101JA01D C135		1/10/P								
386	D0-04101001	GRM188B11H102KA01D C136		1/10/P								
387	D0-04101001	GRM188B11H102KA01D C137		1/10/P								
388	D0-04101001	GRM188B11H102KA01D C138		1/10/P								
389	D0-04098001	GRM188F11E104ZA01D C139		1/10/P								
390	D0-15993001	C140		1								
391	D0-04042001	C1608JF1H104ZT C141		1/10/P								
392	D0-04098001	GRM188F11E104ZA01D C142		1/10/P								
393	D0-16002001			1								

ITEM NO.	PARTS NO.	PARTS NAME	Q'TY / PAGE	Q'TY / PACK	PIR	BSI NO.	TO	T	FROM	SERIAL NO.	REMARKS	C
394	D0-04042001	C143 C1608JF1H104ZT		1/10/P								
395	D0-16002001	C144		1								
396	D0-15993001	C145		1								
397	D0-04099001	C146 GRM188F11C104ZA01D		1/10/P								
398	D0-04099001	C147 GRM188F11C104ZA01D		1/10/P								
399	D0-04099001	C148 GRM188F11C104ZA01D		1/10/P								
400	D0-04099001	C149 GRM188F11C104ZA01D		1/10/P								
401	D0-04099001	C150 GRM188F11C104ZA01D		1/10/P								
402	D0-04099001	C151 GRM188F11C104ZA01D		1/10/P								
403	D0-04099001	C152 GRM188F11C104ZA01D		1/10/P								
404	D0-04099001	C153 GRM188F11C104ZA01D		1/10/P								
405	D0-04099001	C154 GRM188F11C104ZA01D		1/10/P								
406	D0-04099001	C155 GRM188F11C104ZA01D		1/10/P								
407	D0-04099001	C156 GRM188F11C104ZA01D		1/10/P								
408	D0-04099001	C157 GRM188F11C104ZA01D		1/10/P								
435	D0-04098001	C158 GRM188F11E104ZA01D		1/10/P								
437	D0-05723001	C185 GRM21BF11C105ZA01L		1/10/P								
438	D0-05723001	C187 GRM21BF11C105ZA01L		1/10/P								
439	D0-05723001	C188 GRM21BF11C105ZA01L		1/10/P								
440	D0-05723001	C189 GRM21BF11C105ZA01L		1/10/P								
441	D0-04098001	C190 GRM188F11E104ZA01D		1/10/P								
442	D0-04098001	C191 GRM188F11E104ZA01D		1/10/P								
443	D0-04098001	C192 GRM188F11E104ZA01D		1/10/P								
444	D0-04098001	C193 GRM188F11E104ZA01D		1/10/P								
445	D0-04085001	C194 GRM1882C1H100JZ01D		1/10/P								
446	D0-04092001	C195 GRM188B11H222KA01D		1/10/P								
459	D0-04098001	C196 GRM188F11E104ZA01D		1/10/P								
461	D0-04098001	C209 GRM188F11E104ZA01D		1/10/P								
462	D0-04098001	C211 GRM188F11E104ZA01D		1/10/P								
467	D0-15995001	C212		1								
468	D0-15995001	C217		1								
469	D0-04098001	C218 GRM188F11E104ZA01D		1/10/P								
470	D0-15995001	C219		1								
473	D0-04090001	C220 GRM1882C1H471JA01D		1/10/P								
		C223										

ITEM NO.	PARTS NO.	PARTS NAME	Q'TY / PAGE	Q'TY / PACK	PIR	BSI NO.	TO	T	FROM	SERIAL NO.	REMARKS	C
474	D0-04090001	GRM1882C1H471JA01D C224		1/10/P								
490	D0-15996001	C240		1								
491	D0-04098001	GRM188F11E104ZA01D C241		1/10/P								
492	D0-04093001	GRM1882C1H220JZ01D C242		1/10/P								
493	D0-15996001	C243		1								
540	D0-04098001	GRM188F11E104ZA01D C290		1/10/P								
558	D0-04042001	C1608JF1H104ZT C308		1/10/P								
586	D0-04098001	GRM188F11E104ZA01D C336		1/10/P								
850	D0-04099001	GRM188F11C104ZA01D C600		1/10/P								
851	D0-04099001	GRM188F11C104ZA01D C601		1/10/P								
852	D0-04099001	GRM188F11C104ZA01D C602		1/10/P								
853	D0-04099001	GRM188F11C104ZA01D C603		1/10/P								
854	D0-04099001	GRM188F11C104ZA01D C604		1/10/P								
855	D0-04099001	GRM188F11C104ZA01D C605		1/10/P								
857	D0-04099001	GRM188F11C104ZA01D C607		1/10/P								
858	D0-04099001	GRM188F11C104ZA01D C608		1/10/P								
860	D0-04042001	C1608JF1H104ZT C610		1/10/P								
861	D0-04042001	C1608JF1H104ZT C611		1/10/P								
862	D0-04099001	GRM188F11C104ZA01D C612		1/10/P								
863	D0-04099001	GRM188F11C104ZA01D C613		1/10/P								
864	D0-04099001	GRM188F11C104ZA01D C614		1/10/P								
865	D0-04099001	GRM188F11C104ZA01D C615		1/10/P								
866	D0-04099001	GRM188F11C104ZA01D C616		1/10/P								
867	D0-04099001	GRM188F11C104ZA01D C617		1/10/P								
868	D0-04099001	GRM188F11C104ZA01D C618		1/10/P								
869	D0-04099001	GRM188F11C104ZA01D C619		1/10/P								
870	D0-04099001	GRM188F11C104ZA01D C620		1/10/P								
871	D0-04099001	GRM188F11C104ZA01D C621		1/10/P								
872	D0-04042001	C1608JF1H104ZT C622		1/10/P								
873	D0-04042001	C1608JF1H104ZT C623		1/10/P								
874	D0-04042001	C1608JF1H104ZT C624		1/10/P								
875	D0-04042001	C1608JF1H104ZT C625		1/10/P								
876	D0-04042001	C1608JF1H104ZT C626		1/10/P								
900	D0-04042001	C1608JF1H104ZT C650		1/10/P								
901	D0-04042001	C1608JF1H104ZT		1/10/P								

ITEM NO.	PARTS NO.	PARTS NAME	Q'TY / PAGE	Q'TY / PACK	P	I	R	BSI NO.	TO	T	FROM	SERIAL NO.	REMARKS	C
902	D0-04042001	C651 C1608JF1H104ZT		1/10/P										
903	D0-04042001	C652 C1608JF1H104ZT		1/10/P										
904	D0-04042001	C653 C1608JF1H104ZT		1/10/P										
905	D0-04042001	C654 C1608JF1H104ZT		1/10/P										
906	D0-04042001	C655 C1608JF1H104ZT		1/10/P										
907	D0-04042001	C656 C1608JF1H104ZT		1/10/P										
908	D0-04042001	C657 C1608JF1H104ZT		1/10/P										
		C658												

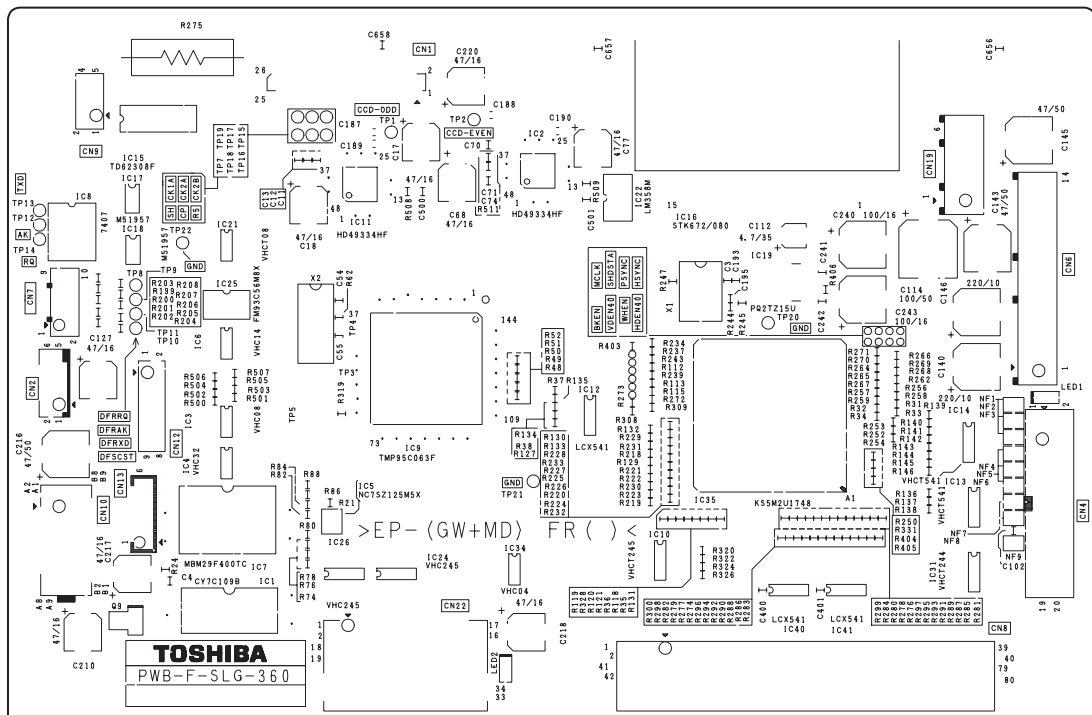

ITEM NO.	PARTS NO.	PARTS NAME	Q'TY / PAGE	Q'TY / PACK	P	I	R	B S I NO.	T O	T	F R O M	S E R I A L NO.	R E M A R K S	C
1	D0-01020001	MCR03EZHZ472		110/P										
		R1												
2	D0-01020001	MCR03EZHZ472		110/P										
		R2												
3	D0-01020001	MCR03EZHZ472		110/P										
		R3												
4	D0-01020001	MCR03EZHZ472		110/P										
		R4												
5	D0-01020001	MCR03EZHZ472		110/P										
		R5												
6	D0-01020001	MCR03EZHZ472		110/P										
		R6												
7	D0-01020001	MCR03EZHZ472		110/P										
		R7												
8	D0-01020001	MCR03EZHZ472		110/P										
		R8												
9	D0-01020001	MCR03EZHZ472		110/P										
		R9												
12	D0-01020001	MCR03EZHZ472		110/P										
		R12												
13	D0-01020001	MCR03EZHZ472		110/P										
		R13												
14	D0-01020001	MCR03EZHZ472		110/P										
		R14												
15	D0-01020001	MCR03EZHZ472		110/P										
		R15												
16	D0-01020001	MCR03EZHZ472		110/P										
		R16												
17	D0-01020001	MCR03EZHZ472		110/P										
		R17												
18	D0-01020001	MCR03EZHZ472		110/P										
		R18												
19	D0-01020001	MCR03EZHZ472		110/P										
		R19												
20	D0-00951001	MCR03EZHZ101		110/P										
		R20												
21	D0-00951001	MCR03EZHZ101		110/P										
		R21												
22	D0-00951001	MCR03EZHZ101		110/P										
		R22												
23	D0-00953001	MCR03EZHZ103		110/P										
		R23												
24	D0-00949001	MCR03EZHZ000		110/P										
		R24												
25	D0-00949001	MCR03EZHZ000		110/P										
		R25												
28	D0-00951001	MCR03EZHZ101		110/P										
		R28												
29	D0-00951001	MCR03EZHZ101		110/P										
		R29												
30	D0-00951001	MCR03EZHZ101		110/P										
		R30												
31	D0-00950001	MCR03EZHZ100		110/P										
		R31												
32	D0-00950001	MCR03EZHZ100		110/P										
		R32												
33	D0-00950001	MCR03EZHZ100		110/P										
		R33												
34	D0-00950001	MCR03EZHZ100		110/P										
		R34												
35	D0-00981001	MCR03EZHZ220		110/P										
		R35												
36	D0-00981001	MCR03EZHZ220		110/P										
		R36												
39	D0-01005001	MCR03EZHZ333		15/										
		R39												
43	D0-00949001	MCR03EZHZ000		110/P										
		R43												
44	D0-00949001	MCR03EZHZ000		110/P										

ITEM NO.	PARTS NO.	PARTS NAME	Q'TY / PAGE	Q'TY / PACK	PIR	BSI NO.	TO	T	FROM	SERIAL NO.	REMARKS	C
45	D0-00984001	R44 MCR03EZHZJ223		1/10/P								
46	D0-01020001	R45 MCR03EZHZJ472		1/10/P								
47	D0-00984001	R46 MCR03EZHZJ223		1/10/P								
48	D0-00953001	R47 MCR03EZHZJ103		1/10/P								
49	D0-00953001	R48 MCR03EZHZJ103		1/10/P								
50	D0-00953001	R49 MCR03EZHZJ103		1/10/P								
51	D0-00953001	R50 MCR03EZHZJ103		1/10/P								
52	D0-00953001	R51 MCR03EZHZJ103		1/10/P								
54	D0-00953001	R52 MCR03EZHZJ103		1/10/P								
55	D0-00981001	R54 MCR03EZHZJ220		1/10/P								
56	D0-00953001	R55 MCR03EZHZJ103		1/10/P								
57	D0-00981001	R56 MCR03EZHZJ220		1/10/P								
58	D0-00965001	R57 MCR03EZHZJ151		1/10/P								
59	D0-00951001	R58 MCR03EZHZJ101		1/10/P								
60	D0-00951001	R59 MCR03EZHZJ101		1/10/P								
61	D0-00981001	R60 MCR03EZHZJ220		1/10/P								
62	D0-00955001	R61 MCR03EZHZJ105		1/10/P								
63	D0-01020001	R62 MCR03EZHZJ472		1/10/P								
64	D0-01020001	R63 MCR03EZHZJ472		1/10/P								
67	D0-01020001	R64 MCR03EZHZJ472		1/10/P								
68	D0-01020001	R67 MCR03EZHZJ472		1/10/P								
69	D0-01020001	R68 MCR03EZHZJ472		1/10/P								
70	D0-01020001	R69 MCR03EZHZJ472		1/10/P								
71	D0-00951001	R70 MCR03EZHZJ101		1/10/P								
72	D0-00951001	R71 MCR03EZHZJ101		1/10/P								
73	D0-01020001	R72 MCR03EZHZJ472		1/10/P								
74	D0-01038001	R73 MCR03EZHZJ682		1/5/								
75	D0-01020001	R74 MCR03EZHZJ472		1/10/P								
76	D0-01038001	R75 MCR03EZHZJ682		1/5/								
77	D0-01020001	R76 MCR03EZHZJ472		1/10/P								
78	D0-01038001	R77 MCR03EZHZJ682		1/5/								
79	D0-01020001	R78 MCR03EZHZJ472		1/10/P								
80	D0-01038001	R79 MCR03EZHZJ682		1/5/								
81	D0-01020001	R80 MCR03EZHZJ472		1/10/P								
		R81										

ITEM NO.	PARTS NO.	PARTS NAME	Q'TY / PAGE	Q'TY / PACK	PIR	BSI NO.	TO	T	FROM	SERIAL NO.	REMARKS	C
82	D0-01038001	MCR03EZHZJ682 R82		15/								
83	D0-01020001	MCR03EZHZJ472 R83		110/P								
84	D0-01038001	MCR03EZHZJ682 R84		15/								
85	D0-01020001	MCR03EZHZJ472 R85		110/P								
86	D0-01038001	MCR03EZHZJ682 R86		15/								
87	D0-01020001	MCR03EZHZJ472 R87		110/P								
88	D0-01038001	MCR03EZHZJ682 R88		15/								
89	D0-01020001	MCR03EZHZJ472 R89		110/P								
90	D0-01038001	MCR03EZHZJ682 R90		15/								
91	D0-01020001	MCR03EZHZJ472 R91		110/P								
92	D0-01038001	MCR03EZHZJ682 R92		15/								
93	D0-01020001	MCR03EZHZJ472 R93		110/P								
94	D0-01038001	MCR03EZHZJ682 R94		15/								
95	D0-01020001	MCR03EZHZJ472 R95		110/P								
96	D0-01038001	MCR03EZHZJ682 R96		15/								
97	D0-01020001	MCR03EZHZJ472 R97		110/P								
98	D0-01038001	MCR03EZHZJ682 R98		15/								
99	D0-01020001	MCR03EZHZJ472 R99		110/P								
100	D0-01038001	MCR03EZHZJ682 R100		15/								
101	D0-01020001	MCR03EZHZJ472 R101		110/P								
102	D0-01038001	MCR03EZHZJ682 R102		15/								
103	D0-01020001	MCR03EZHZJ472 R103		110/P								
104	D0-01038001	MCR03EZHZJ682 R104		15/								
108	D0-01005001	MCR03EZHZJ333 R108		15/								
109	D0-00951001	MCR03EZHZJ101 R109		110/P								
110	D0-00951001	MCR03EZHZJ101 R110		110/P								
111	D0-00951001	MCR03EZHZJ101 R111		110/P								
112	D0-00951001	MCR03EZHZJ101 R112		110/P								
113	D0-00951001	MCR03EZHZJ101 R113		110/P								
116	D0-01020001	MCR03EZHZJ472 R116		110/P								
117	D0-00951001	MCR03EZHZJ101 R117		110/P								
118	D0-00981001	MCR03EZHZJ220 R118		110/P								
119	D0-00981001	MCR03EZHZJ220 R119		110/P								
120	D0-00981001	MCR03EZHZJ220 R120		110/P								
121	D0-00981001	MCR03EZHZJ220		110/P								

ITEM NO.	PARTS NO.	PARTS NAME	Q'TY / PAGE	Q'TY / PACK	PIR	BSI NO.	TO	T	FROM	SERIAL NO.	REMARKS	C
122	D0-01020001	R121 MCR03EZHZJ472		110/P								
123	D0-01020001	R122 MCR03EZHZJ472		110/P								
124	D0-01020001	R123 MCR03EZHZJ472		110/P								
125	D0-01020001	R124 MCR03EZHZJ472		110/P								
126	D0-01020001	R125 MCR03EZHZJ472		110/P								
128	D0-01020001	R126 MCR03EZHZJ472		110/P								
129	D0-01020001	R128 MCR03EZHZJ472		110/P								
130	D0-00951001	R129 MCR03EZHZJ101		110/P								
131	D0-01020001	R130 MCR03EZHZJ472		110/P								
132	D0-00951001	R131 MCR03EZHZJ101		110/P								
133	D0-00951001	R132 MCR03EZHZJ101		110/P								
136	D0-00951001	R133 MCR03EZHZJ101		110/P								
137	D0-00951001	R136 MCR03EZHZJ101		110/P								
138	D0-00951001	R137 MCR03EZHZJ101		110/P								
139	D0-00951001	R138 MCR03EZHZJ101		110/P								
140	D0-00951001	R139 MCR03EZHZJ101		110/P								
141	D0-00951001	R140 MCR03EZHZJ101		110/P								
142	D0-00951001	R141 MCR03EZHZJ101		110/P								
143	D0-00951001	R142 MCR03EZHZJ101		110/P								
144	D0-00951001	R143 MCR03EZHZJ101		110/P								
145	D0-00951001	R144 MCR03EZHZJ101		110/P								
146	D0-00951001	R145 MCR03EZHZJ101		110/P								
147	D0-01036001	R146 MCR03EZHZJ680		110/P								
148	D0-01036001	R147 MCR03EZHZJ680		110/P								
149	D0-01036001	R148 MCR03EZHZJ680		110/P								
150	D0-01036001	R149 MCR03EZHZJ680		110/P								
151	D0-01036001	R150 MCR03EZHZJ680		110/P								
152	D0-01036001	R151 MCR03EZHZJ680		110/P								
153	D0-01036001	R152 MCR03EZHZJ680		110/P								
154	D0-01036001	R153 MCR03EZHZJ680		110/P								
155	D0-01036001	R154 MCR03EZHZJ680		110/P								
156	D0-01036001	R155 MCR03EZHZJ680		110/P								
157	D0-01036001	R156 MCR03EZHZJ680		110/P								
158	D0-00951001	R157 MCR03EZHZJ101		110/P								
		R158										

ITEM NO.	PARTS NO.	PARTS NAME	Q'TY / PAGE	Q'TY / PACK	PIR	BSI NO.	TO	T	FROM	SERIAL NO.	REMARKS	C
159	D0-01020001	MCR03EZHJ472 R159		110/P								
160	D0-00952001	MCR03EZHJ102 R160		110/P								
161	D0-00952001	MCR03EZHJ102 R161		110/P								
162	D0-01020001	MCR03EZHJ472 R162		110/P								
163	D0-00951001	MCR03EZHJ101 R163		110/P								
165	D0-00953001	MCR03EZHJ103 R165		110/P								
166	D0-01012001	MCR03EZHJ392 R166		15/								
169	D0-00951001	MCR03EZHJ101 R169		110/P								
170	D0-00953001	MCR03EZHJ103 R170		110/P								
171	D0-00953001	MCR03EZHJ103 R171		110/P								
172	D0-00953001	MCR03EZHJ103 R172		110/P								
173	D0-00953001	MCR03EZHJ103 R173		110/P								
174	D0-00949001	MCR03EZHJ000 R174		110/P								
175	D0-00951001	MCR03EZHJ101 R175		110/P								
176	D0-01041001	MCR03EZHJ750 R176		15/								
177	D0-01020001	MCR03EZHJ472 R177		110/P								
178	D0-01012001	MCR03EZHJ392 R178		15/								
179	D0-01020001	MCR03EZHJ472 R179		110/P								
180	D0-01020001	MCR03EZHJ472 R180		110/P								
181	D0-01020001	MCR03EZHJ472 R181		110/P								
182	D0-01020001	MCR03EZHJ472 R182		110/P								
183	D0-01020001	MCR03EZHJ472 R183		110/P								
184	D0-00984001	MCR03EZHJ223 R184		110/P								
185	D0-00984001	MCR03EZHJ223 R185		110/P								
186	D0-00984001	MCR03EZHJ223 R186		110/P								
187	D0-00984001	MCR03EZHJ223 R187		110/P								
188	D0-00984001	MCR03EZHJ223 R188		110/P								
189	D0-01020001	MCR03EZHJ472 R189		110/P								
190	D0-01020001	MCR03EZHJ472 R190		110/P								
191	D0-00984001	MCR03EZHJ223 R191		110/P								
192	D0-00984001	MCR03EZHJ223 R192		110/P								
199	D0-01020001	MCR03EZHJ472 R199		110/P								
200	D0-01020001	MCR03EZHJ472 R200		110/P								
201	D0-01020001	MCR03EZHJ472 R201		110/P								
202	D0-01020001	MCR03EZHJ472		110/P								

ITEM NO.	PARTS NO.	PARTS NAME	Q'TY / PAGE	Q'TY / PACK	PIR	BSI NO.	TO	T	FROM	SERIAL NO.	REMARKS	C
203	D0-01020001	R202 MCR03EZHZJ472		1/10/P								
204	D0-00984001	R203 MCR03EZHZJ223		1/10/P								
205	D0-00984001	R204 MCR03EZHZJ223		1/10/P								
206	D0-00984001	R205 MCR03EZHZJ223		1/10/P								
207	D0-00984001	R206 MCR03EZHZJ223		1/10/P								
208	D0-00984001	R207 MCR03EZHZJ223		1/10/P								
218	D0-00951001	R208 MCR03EZHZJ101		1/10/P								
219	D0-00951001	R218 MCR03EZHZJ101		1/10/P								
220	D0-00951001	R219 MCR03EZHZJ101		1/10/P								
221	D0-00951001	R220 MCR03EZHZJ101		1/10/P								
222	D0-00951001	R221 MCR03EZHZJ101		1/10/P								
223	D0-00951001	R222 MCR03EZHZJ101		1/10/P								
224	D0-00951001	R223 MCR03EZHZJ101		1/10/P								
225	D0-00951001	R224 MCR03EZHZJ101		1/10/P								
226	D0-00951001	R225 MCR03EZHZJ101		1/10/P								
227	D0-00951001	R226 MCR03EZHZJ101		1/10/P								
228	D0-00951001	R227 MCR03EZHZJ101		1/10/P								
229	D0-00951001	R228 MCR03EZHZJ101		1/10/P								
230	D0-00951001	R229 MCR03EZHZJ101		1/10/P								
231	D0-00951001	R230 MCR03EZHZJ101		1/10/P								
232	D0-00951001	R231 MCR03EZHZJ101		1/10/P								
233	D0-00951001	R232 MCR03EZHZJ101		1/10/P								
234	D0-01020001	R233 MCR03EZHZJ472		1/10/P								
235	D0-01020001	R234 MCR03EZHZJ472		1/10/P								
236	D0-01020001	R235 MCR03EZHZJ472		1/10/P								
237	D0-00951001	R236 MCR03EZHZJ101		1/10/P								
238	D0-01020001	R237 MCR03EZHZJ472		1/10/P								
239	D0-00951001	R238 MCR03EZHZJ101		1/10/P								
240	D0-01020001	R239 MCR03EZHZJ472		1/10/P								
241	D0-01020001	R240 MCR03EZHZJ472		1/10/P								
242	D0-01020001	R241 MCR03EZHZJ472		1/10/P								
243	D0-00951001	R242 MCR03EZHZJ101		1/10/P								
244	D0-00951001	R243 MCR03EZHZJ101		1/10/P								
245	D0-00950001	R244 MCR03EZHZJ100		1/10/P								
		R245										

ITEM NO.	PARTS NO.	PARTS NAME	Q'TY / PAGE	Q'TY / PACK	P	I	R	B S I NO.	T O	T	F R O M	S E R I A L NO.	R E M A R K S	C
246	D0-01020001	MCR03EZHZ472 R246		1/10/P										
247	D0-00983001	MCR03EZHZ222 R247		1/10/P										
248	D0-01020001	MCR03EZHZ472 R248		1/10/P										
249	D0-00952001	MCR03EZHZ102 R249		1/10/P										
250	D0-01020001	MCR03EZHZ472 R250		1/10/P										
252	D0-00950001	MCR03EZHZ100 R252		1/10/P										
253	D0-00950001	MCR03EZHZ100 R253		1/10/P										
254	D0-00950001	MCR03EZHZ100 R254		1/10/P										
255	D0-01020001	MCR03EZHZ472 R255		1/10/P										
256	D0-00950001	MCR03EZHZ100 R256		1/10/P										
257	D0-00950001	MCR03EZHZ100 R257		1/10/P										
258	D0-00950001	MCR03EZHZ100 R258		1/10/P										
259	D0-00950001	MCR03EZHZ100 R259		1/10/P										
260	D0-00984001	MCR03EZHZ223 R260		1/10/P										
261	D0-00951001	MCR03EZHZ101 R261		1/10/P										
262	D0-01020001	MCR03EZHZ472 R262		1/10/P										
263	D0-01041001	MCR03EZHZ750 R263		1/5/										
264	D0-00950001	MCR03EZHZ100 R264		1/10/P										
265	D0-00950001	MCR03EZHZ100 R265		1/10/P										
266	D0-00950001	MCR03EZHZ100 R266		1/10/P										
267	D0-00950001	MCR03EZHZ100 R267		1/10/P										
268	D0-00950001	MCR03EZHZ100 R268		1/10/P										
269	D0-00950001	MCR03EZHZ100 R269		1/10/P										
270	D0-00950001	MCR03EZHZ100 R270		1/10/P										
271	D0-00950001	MCR03EZHZ100 R271		1/10/P										
272	D0-00951001	MCR03EZHZ101 R272		1/10/P										
273	D0-00951001	MCR03EZHZ101 R273		1/10/P										
274	D0-00981001	MCR03EZHZ220 R274		1/10/P										
276	D0-00981001	MCR03EZHZ220 R276		1/10/P										
277	D0-00981001	MCR03EZHZ220 R277		1/10/P										
278	D0-00981001	MCR03EZHZ220 R278		1/10/P										
279	D0-00981001	MCR03EZHZ220 R279		1/10/P										
280	D0-00981001	MCR03EZHZ220 R280		1/10/P										
281	D0-00981001	MCR03EZHZ220 R281		1/10/P										
282	D0-00981001	MCR03EZHZ220		1/10/P										

ITEM NO.	PARTS NO.	PARTS NAME	Q'TY / PAGE	Q'TY / PACK	PIR	BSI NO.	TO	T	FROM	SERIAL NO.	REMARKS	C
283	D0-00981001	R282 MCR03EZHJ220		1/10/P								
284	D0-00981001	R283 MCR03EZHJ220		1/10/P								
285	D0-00981001	R284 MCR03EZHJ220		1/10/P								
286	D0-00981001	R285 MCR03EZHJ220		1/10/P								
287	D0-00981001	R286 MCR03EZHJ220		1/10/P								
288	D0-00981001	R287 MCR03EZHJ220		1/10/P								
289	D0-00981001	R288 MCR03EZHJ220		1/10/P								
290	D0-00981001	R289 MCR03EZHJ220		1/10/P								
291	D0-00981001	R290 MCR03EZHJ220		1/10/P								
292	D0-00981001	R291 MCR03EZHJ220		1/10/P								
293	D0-00981001	R292 MCR03EZHJ220		1/10/P								
294	D0-00981001	R293 MCR03EZHJ220		1/10/P								
295	D0-00981001	R294 MCR03EZHJ220		1/10/P								
296	D0-00981001	R295 MCR03EZHJ220		1/10/P								
297	D0-00981001	R296 MCR03EZHJ220		1/10/P								
298	D0-00981001	R297 MCR03EZHJ220		1/10/P								
299	D0-00981001	R298 MCR03EZHJ220		1/10/P								
300	D0-00981001	R299 MCR03EZHJ220		1/10/P								
303	D0-00951001	R300 MCR03EZHJ101		1/10/P								
304	D0-01020001	R303 MCR03EZHJ472		1/10/P								
305	D0-01020001	R304 MCR03EZHJ472		1/10/P								
306	D0-01020001	R305 MCR03EZHJ472		1/10/P								
307	D0-01020001	R306 MCR03EZHJ472		1/10/P								
308	D0-00951001	R307 MCR03EZHJ101		1/10/P								
309	D0-00951001	R308 MCR03EZHJ101		1/10/P								
310	D0-00951001	R309 MCR03EZHJ101		1/10/P								
311	D0-00951001	R310 MCR03EZHJ101		1/10/P								
312	D0-00951001	R311 MCR03EZHJ101		1/10/P								
318	D0-00951001	R312 MCR03EZHJ101		1/10/P								
319	D0-00965001	R318 MCR03EZHJ151		1/10/P								
320	D0-01020001	R319 MCR03EZHJ472		1/10/P								
321	D0-01020001	R320 MCR03EZHJ472		1/10/P								
322	D0-01020001	R321 MCR03EZHJ472		1/10/P								
323	D0-01020001	R322 MCR03EZHJ472		1/10/P								
		R323										

ITEM NO.	PARTS NO.	PARTS NAME	Q'TY / PAGE	Q'TY / PACK	P	I	R	BSI NO.	TO	T	FROM	SERIAL NO.	REMARKS	C
324	D0-01020001	MCR03EZHJ472 R324		1/10/P										
325	D0-01020001	MCR03EZHJ472 R325		1/10/P										
326	D0-01020001	MCR03EZHJ472 R326		1/10/P										
327	D0-01020001	MCR03EZHJ472 R327		1/10/P										
328	D0-00981001	MCR03EZHJ220 R328		1/10/P										
329	D0-00951001	MCR03EZHJ101 R329		1/10/P										
330	D0-00951001	MCR03EZHJ101 R330		1/10/P										
331	D0-00950001	MCR03EZHJ100 R331		1/10/P										
357	D0-00951001	MCR03EZHJ101 R357		1/10/P										
358	D0-00949001	MCR03EZHJ000 R358		1/10/P										
400	D0-00951001	MCR03EZHJ101 R400		1/10/P										
401	D0-00953001	MCR03EZHJ103 R401		1/10/P										
402	D0-00953001	MCR03EZHJ103 R402		1/10/P										
403	D0-00951001	MCR03EZHJ101 R403		1/10/P										
404	D0-01020001	MCR03EZHJ472 R404		1/10/P										
405	D0-01020001	MCR03EZHJ472 R405		1/10/P										
406	D0-00953001	MCR03EZHJ103 R406		1/10/P										
407	D0-00951001	MCR03EZHJ101 R407		1/10/P										
510	D0-00951001	MCR03EZHJ101 R510		1/10/P										
511	D0-00951001	MCR03EZHJ101 R511		1/10/P										
600	D0-00951001	MCR03EZHJ101 R600		1/10/P										
601	D0-01020001	MCR03EZHJ472 R601		1/10/P										
602	D0-01020001	MCR03EZHJ472 R602		1/10/P										
651	E0-07026001	CN1		1										
652	E0-06752000	CN2		1										
654	E0-06559000	CN4		1										
656	E0-04753000	B14B-XASK-1 CN6		1/5/P										
657	E0-06780000	CN7		1										
658	E0-04756000	CN8		1										
659	E0-06588000	CN9		1										
660	E0-06766000	B18B-CZWHK-B-1 (LF) CN10		1/5/P										
669	E0-04745000	B06B-XASK-1 CN19		1/5/P										
672	E0-02160000	DHB-PA34-R13NNA CN22		1/1/P										
701	D0-04472001	FB1		1										
751	D0-18594001	SG-8002IC-20M-PCBL		1/5/S										

ITEM NO.	PARTS NO.	PARTS NAME	Q'TY / PAGE	Q'TY / PACK	P	I	R	B S I NO.	T O	T	F R O M	S E R I A L NO.	R E M A R K S	C
752	D0-06100001	X1 MA-406-22M-8/50L2 X2		11/D										

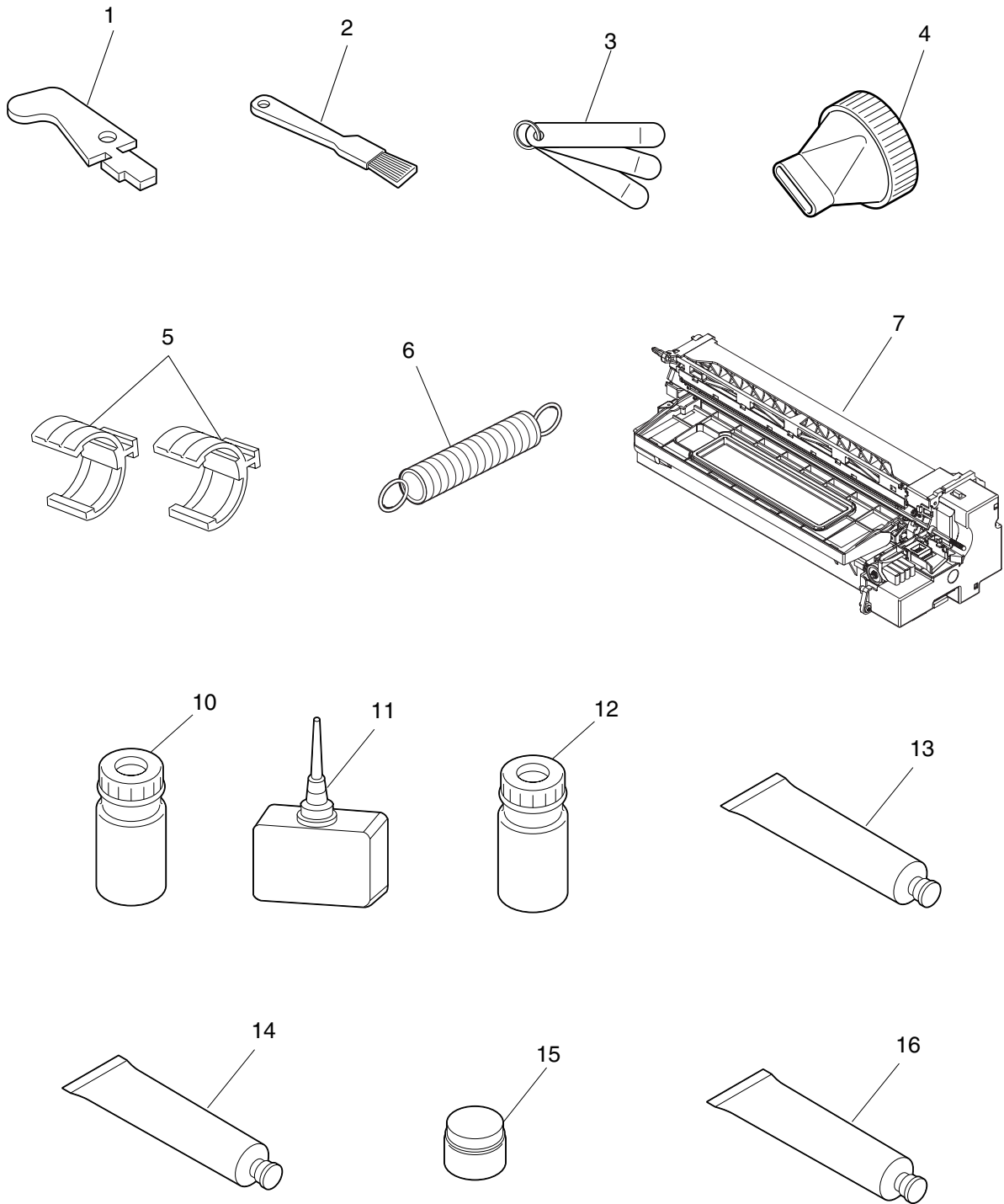

ITEM NO.	PARTS NO.	PARTS NAME	Q'TY / PAGE	Q'TY / PACK	P I R	B S I NO.	T O	T	F R O M	S E R I A L NO.	R E M A R K S	C
1	4407915730	JIG-SW-F-COV		1/1/P								
2	4407915710	BRUSH-33		1/1/P								
3	4402048100	ASM-JIG-DOC-180		1/1/P								
4	4407914000	NOZZLE-BOTTLE		1/1/P								
5	6LA01757000	HOLDER-WIRE-SCAN		2/1/P								
6	44202661000	SPE-MOT-TNS		1/1/P								
7	6LA91605000	ASY-PU-TOOL-F371		1/1/C							High-Voltage measurement jig	
10	4407933080	ASM-SILICONE-1M		1/1/P							Silicon Oil	
11	4842512170	OIL-LAUNA40-100		1/1/P							LAUNA40 100cc	
12A	41303709000	ASM-PG-HP300-S		1/1/D							White grease 100g	
12B	6LA00019000	GREASE-HP300-S		1/1/P							White grease 10g	
13	41303711000	ASM-PG-ALV2		1/1/P							Alvania No.2	
14	4400545160	MOLYKOTE-100		1/1/C								
15	41303710000	ASM-PG-GE334C-S		1/1/C								

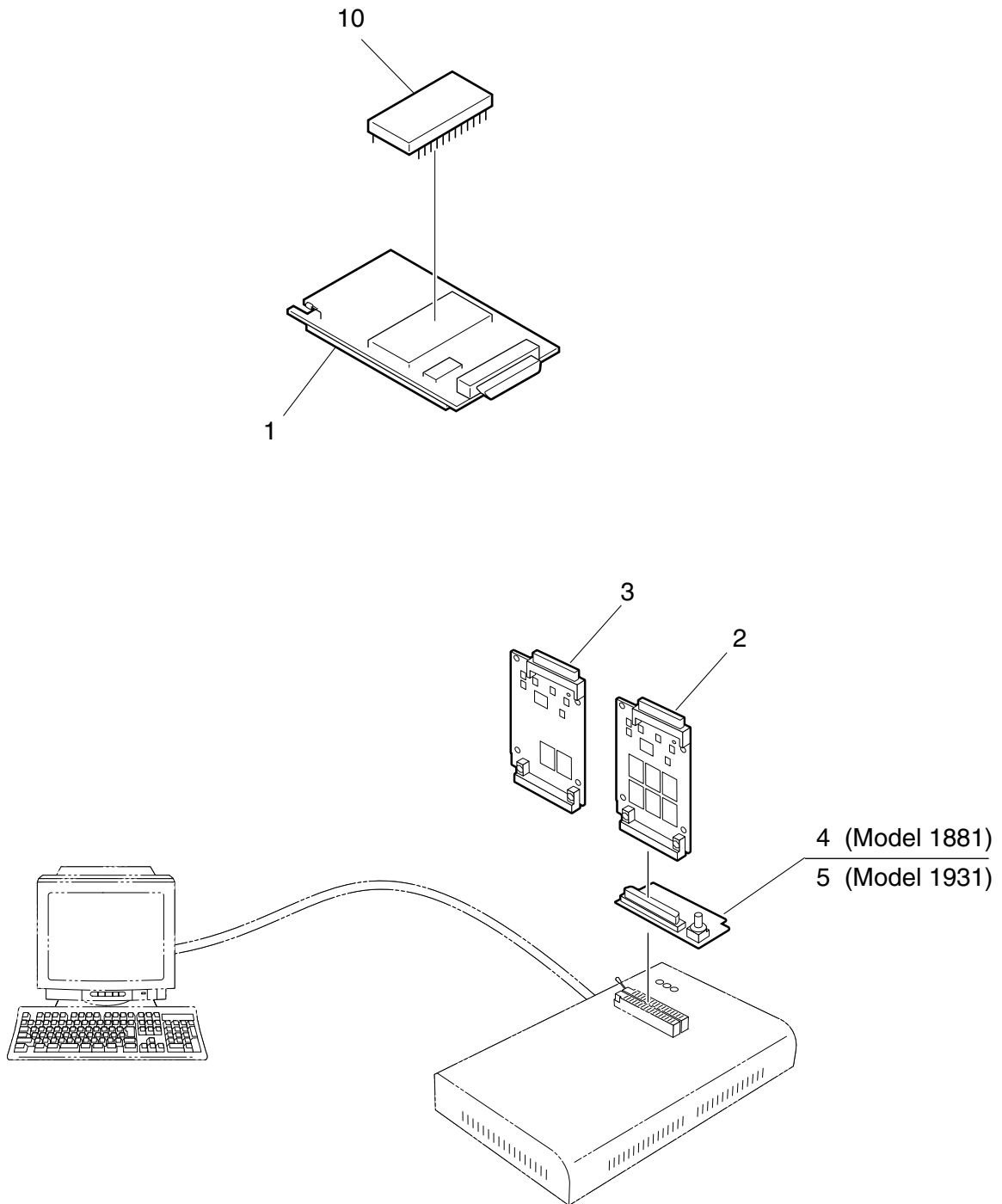

ITEM NO.	PARTS NO.	PARTS NAME	Q'TY / PAGE	Q'TY / PACK	P I R	B S I NO.	T O	T	F R O M	S E R I A L NO.	R E M A R K S	C
1	44205829000	K-PWA-DLM-320		1/1/C								
2	6LA41995000	PWA-DWNLD-350-JIG2		1/1/SB								
3	6LA41994000	PWA-DWNLD-350-JIG1		1/1/SB								
4	6LA41996000	PWA-DL-ADP-350-1881		1/1/S								
5	6LA41997000	PWA-DL-ADP-350-1931		1/1/SB								
10	C0-04530000	M27C4001-10F1		1/1/S								

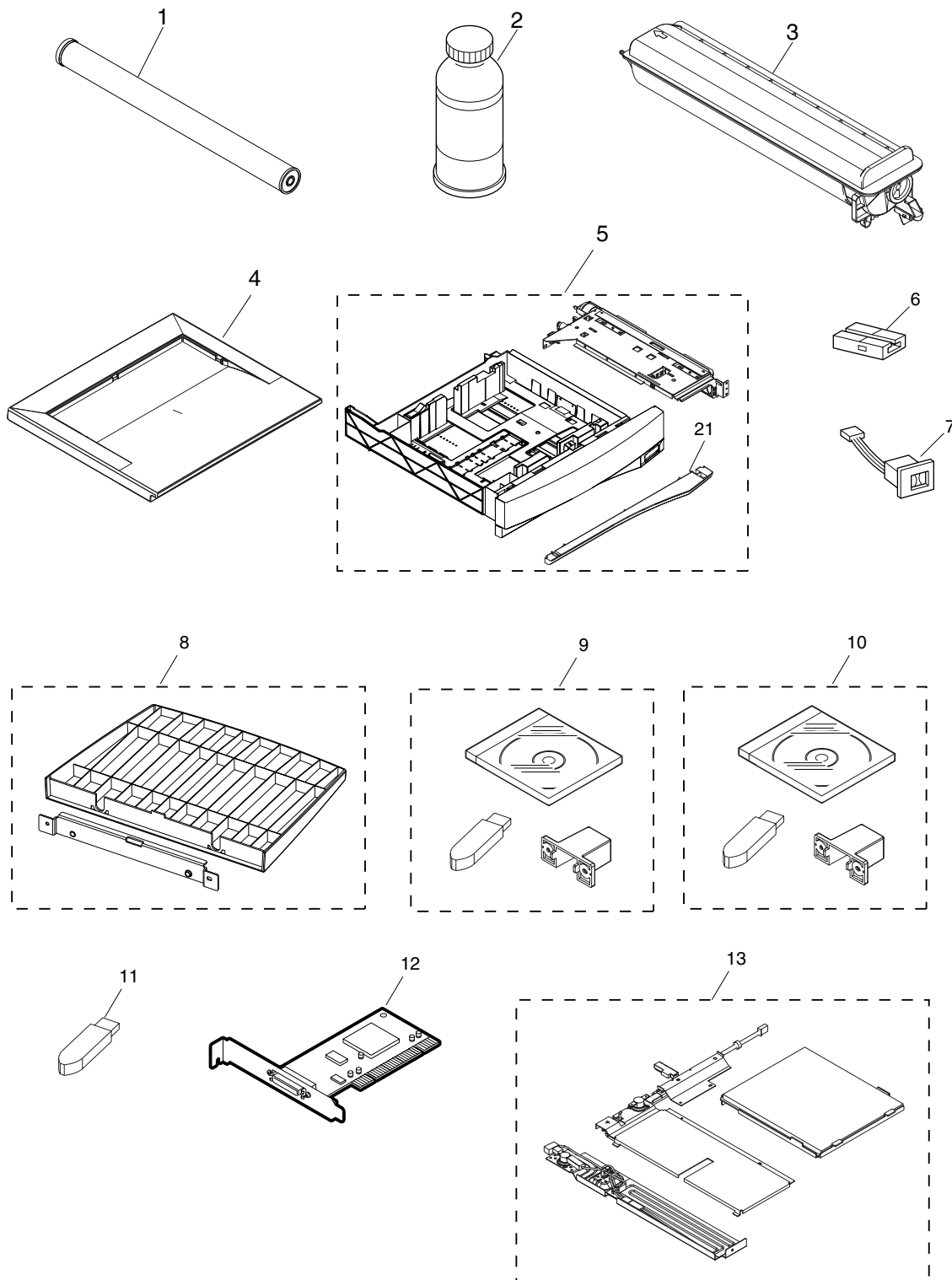

ITEM NO.	PARTS NO.	PARTS NAME	Q'TY / PAGE	Q'TY / PACK	PIR	BSI NO.	TO	T	FROM	SERIAL NO.	REMARKS	C
1A	41303611000	OD-1600		1/1/S							NAD,MJD,AS D.AUD	DRM
1B	6LA27896000	OD-2320		1/1/S							CND	DRM
2A	6LA27715000	D-2320		1/1/S							NAD,MJD,AS D.AUD	DEV
2B	6LA27713000	D-2320C		1/1/S							CND	DEV
3A	6AK00000010	PS-ZT2320(4)		1/SUPPLY							NAD	SUP
3B	6AK00000009	PS-ZT2320E(1)		1/SUPPLY							MJD (TABS/ TPD)	SUP
3C	6AJ00000006	PS-ZT2320E(1)		1/SUPPLY							MJD (TEIS/ TD)	SUP
3D	6AK00000008	PS-ZT2320D(4)		1/SUPPLY							SAD,AUD (T ABS/TPD)	SUP
3E	6AJ00000005	PS-ZT2320D(4)		1/SUPPLY							SAD,AUD (T EIS/TD)	SUP
3F	6AG00000297	PS-ZT2320D(4)		1/SUPPLY							SAD,AUD (T COS)	SUP
3G	6AG00000298	PS-ZT2320C(4)		1/SUPPLY							CND	SUP
3H	6AG00000299	PS-ZT2320T(4)		1/SUPPLY							TWD	SUP
4A	6AR00000032	KA-3511PC		1/SUPPLY							NAD,MJD,SA D.AUD	OPT
4B	6AR00000033	KA-3511PC-N		1/SUPPLY							ASD,TWD	OPT
4C	6AR00000034	KA-3511PC-C		1/SUPPLY							CND	OPT
5A	6AR00000056	MY-1021		1/SUPPLY							NAD,MJD,SA D.AUD	OPT
5B	6AR00000057	MY-1021-N		1/SUPPLY							ASD,TWD	OPT
5C	6AR00000058	MY-1021-C		1/SUPPLY							CND	OPT
6	66002050	MU-8		1/SUPPLY								SUP
7	66002051	MU-10		1/SUPPLY								SUP
8A	6AR00000059	KK-3511		1/SUPPLY							NAD,MJD,SA D.AUD	OPT
8B	6AR00000060	KK-3511-N		1/SUPPLY							ASD,TWD	OPT
8C	6AR00000061	KK-3511-C		1/SUPPLY							CND	OPT
9	6A000000252	GM-1020		1/SUPPLY								SUP
10	6A000000254	GM-2020		1/SUPPLY								OPT
11	6A000000256	GM-3020		1/SUPPLY								OPT
12	66089914	GF-1140		1/SUPPLY								SUP
13A	6A000000257	MF-2320U		1/SUPPLY								OPT
13B	6A000000258	MF-2320E		1/SUPPLY								OPT
21	6LA47822000	COVER-F-SKIRT-PFP		1/1/P								

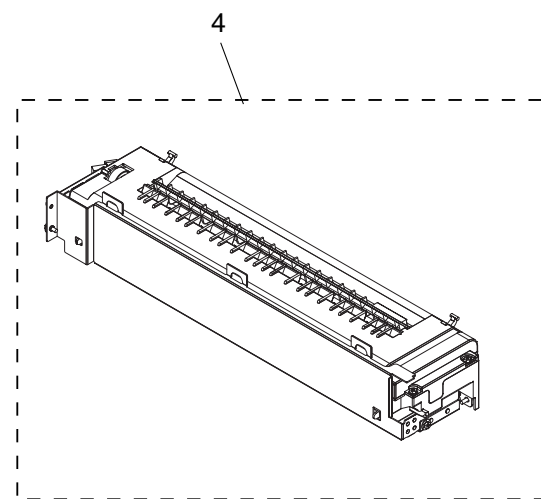
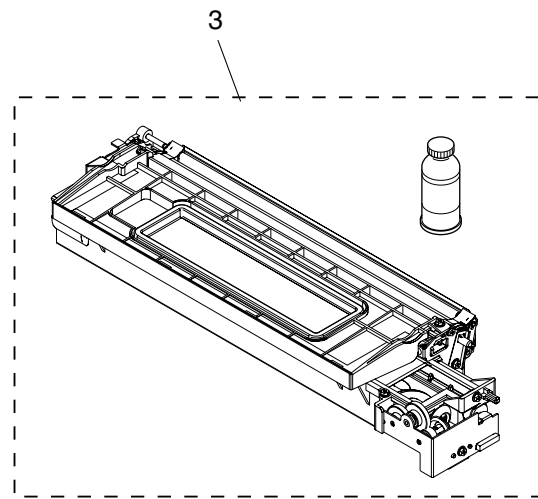
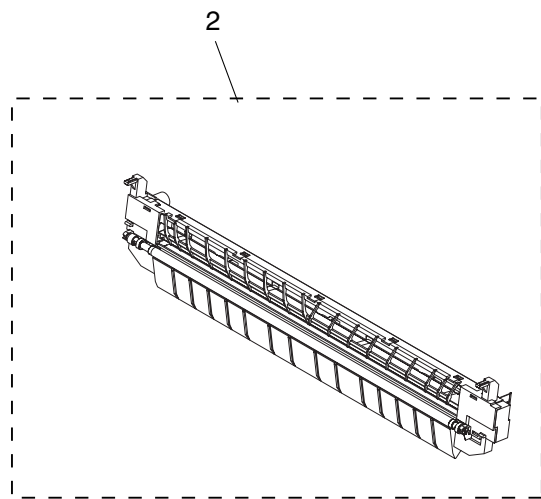
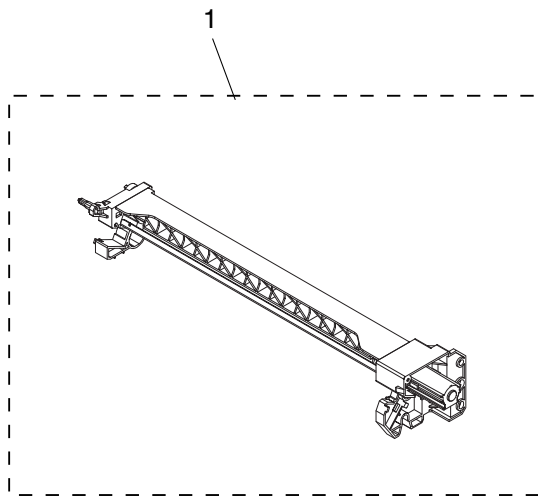

ITEM NO.	PARTS NO.	PARTS NAME	Q'TY / PAGE	Q'TY / PACK	PIR	BSI NO.	TO	T	FROM	SERIAL NO.	REMARKS	C
1	6LA85754000	TR-CH-2320		1/1/C								USE
2	6LA85755000	CLN/DRUM-2320		1/1/C								USE
3	6LA85757000	DEV-UNIT-2320		1/1/S								USE
4A	6LA85759000	FUSER-2320-115		1/1/S							NAD	USE
4B	6LA85760000	FUSER-2320-220		1/1/S							MJD, ASD, AUD	USE

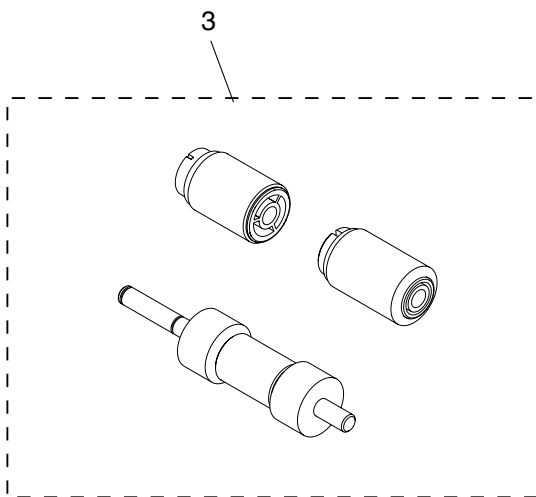
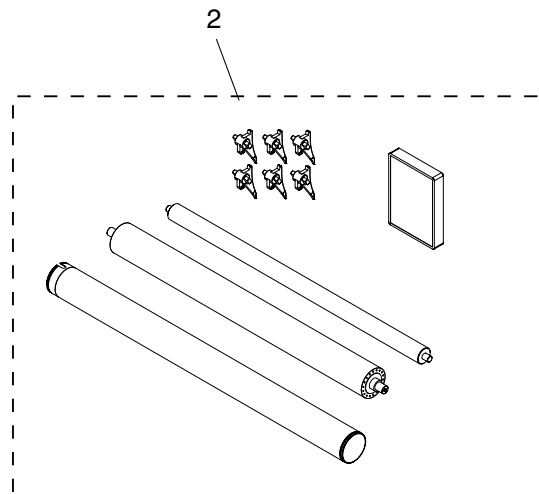
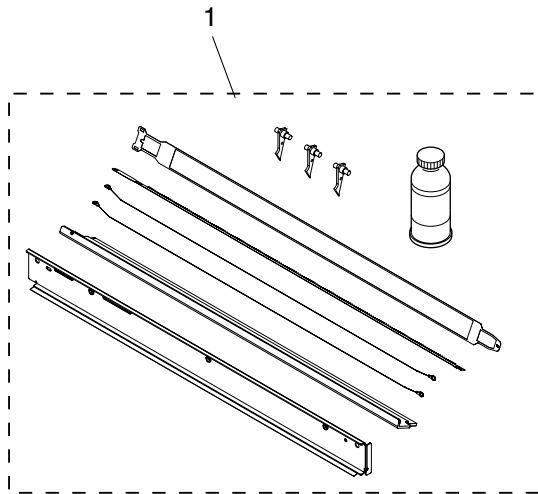

ITEM NO.	PARTS NO.	PARTS NAME	Q'TY / PAGE	Q'TY / PACK	P	I	R	B S I NO.	T O	T	F R O M	S E R I A L NO.	R E M A R K S	C
1	6LA85750000	DEV-KIT-2320	1	1/S										KIT
2	6LA85752000	FR-KIT-2320	1	1/S										KIT
3	41303640000	ROL-KIT-16CST	1	1/S										KIT

TOSHIBA

TOSHIBA TEC CORPORATION

1-1, KANDA NISHIKI-CHO, CHIYODA-KU, TOKYO, 101-8442 JAPAN