

EPSON

FX880+

NB: PART NO. RATIONALISATION –10 digit part nos. in brackets are the old numbers for otherwise identical items

Page 1

REF	PART NO	DESCRIPTION	SPEC	QTY
100	1090493	HOUSING ASSY.,LOWER		1
101	1004605	FOOT		2
102	1040396	HOUSING ASSY.,UPPER;W		1
104	1066760	COVER ASSY.,PRINTER		1
105	1039434	RING		1
106	1040399	SHEET GUIDE ASSY.,REAR		1
107	1090495	COVER ASSY.,FRONT		1
108	1039337	KNOB		1
109	1036515	SHIELD PLATE,UPPER		1
110	1036517	SHIELD PLATE;B		1
111	1064690	SHIELD PLATE		1
112	1005480	GROUNDING PLATE		4
115	1037223	COVER,CONNECTOR,UPPER	EPSON "COOL WHITE"	1
116	1036518	MOUNT,HOUSING		1
117	1064686	GUIDE,I/F BOARD		1
118	1039334	HOLDER,SHEET GUIDE,LEFT		1
119	1039335	HOLDER,SHEET GUIDE,RIGHT		1
120	1090266	LOGO PLATE		1
122	1073114	C.B.(O) SCREW 4X8 F/ZG(B045800115)	M4X8 F/ZG	1
123	1073165	C.B.S. SCREW(B300204211)	M3X6	1
125	1073162	C.B.S. SCREW(B300200111)	M3X4	7
126	1024145	C.B.P.SCREW,4X12,F/ZN		2
128	1002674	C.B.S-TITE SCREW	M3X12	2
132	1064692	GROUNDING PLATE,I/F		1
133	1064693	GROUNDING PLATE,I/F,UPPER		1
135	1039332	SUPPORT,FRAME,SHEET GUIDE,SUB		1
137	1037280	GROUNDING PLATE,BOTTOM		1
140	1025409	PRINTER MECH. MOUNTING SCREW		4
141	1084368	SHEET PANEL	ADDED ITEM	1
200	2055259	BOARD ASSY., MAIN	5796A,STANDARD	1
330	2055263	BOARD ASSY., POWER SUPPLY	5461B,STANDARD:C422	1
372	2048584	HARNESS		1
373	2055732	WIRE HARNESS PSE NARROW		1
400	2006741	POWER CABLE,BS31303SA-SR-10A	240V	1
450	1090494	HOUSING ASSY.,PANEL		1
500	2060301	PRINTER MECHANISM(ASP)M-3O10-100		1
501	1038771	FRAME ASSY.,RIGHT		1
502	1082015	FRAME,ASSY.,LEFT		1
503	2035035	MOTOR ASSY.,CARRIAGE		1
504	1084619	RIBBON DRIVE ASSEMBLY		1
505	1025335	BASE RUBBER		1
510	1006827	GROUNDING PLATE,PAPER EJECT		1
511	2056298	MOTOR,PAPER FEED		1
521	2025898	HARNESS,PG		1
522	2004004	DETECTOR,HP		1
523	2025264	HARNESS,HP		1
524	2014328	CONNECTOR SWITCH;B		1
525	1040232	PAPER GUIDE ASSY.,REAR;W		1

REF	PART NO	DESCRIPTION	SPEC	QTY
526	1005157	SHAFT,RELEASE		1
527	2025262	HARNES,PE,FRONT		1
528	2025263	HARNES,PE,REAR		1
529	2025897	HARNES,RE		1
530	2019011	DETECTOR,PR END,FRONT	0V,0A,0W,	1
531	1005727	DETECTOR ASSY., REAR		1
532	1005213	ROLLER,PF,DRIVEN,LOWER		3
533	1005282	ROLLER ASSY.,PF		1
534	1005215	EXTENSION SPRING,70		1
535	1005214	COMPRESSION SPRING,1000		1
536	1082905	CARRIAGE ASSY.		1
541	1040231	TRACTOR ASS'Y;W		1
542	1039341	TRACTOR,LEFT;W	EPSON "COOL WHITE"	1
543	1039342	TRACTOR,RIGHT;W	EPSON "COOL WHITE"	1
544	1036500	SHAFT,TR,DRIVE		1
545	1083356	SHAFT,TR,GUIDE		1
546	1039351	FRAME,TR,LEFT;W		1
547	1039352	FRAME,TR,RIGHT;W		1
548	1039353	LEVER,TR,LEFT;W		1
549	1039354	LEVER,TR,RIGHT;W		1
550	1025296	PAPER SUPPORT		1
551	1039507	SPUR GEAR,20		1
552	1074768	RETAINING RING(B150300911)	TYPE-E(6)	1
556	1005158	COVER,PAPER EJECT		1
557	1082195	FRAME,PAPER EJECT,BASE		1
558	1039349	FRAME,PAPER EJECT,LEFT;W		1
559	1039350	FRAME,PAPER EJECT,RIGHT;W		1
560	1005243	LEAF SPRING,PAPER EJECT,DOUBLE		1
561	1005244	SPUR GEAR,15		1
562	1005245	SPUR GEAR,18		1
563	1005514	LEAF SPRING,PAPER EJECT,SINGLE		1
564	1036491	ROLLER,PAPER EJECT,DRIVE		1
565	1006901	C.B.C-LAMITITE	M3X8	1
568	2055087	CABLE,HEAD		1
569	1036530	ROLLER ASSY,DRIVE		1
570	1050483	PLATEN ASSY.;B		1
572	1025285	BUSHING,8,RIGHT		1
573	1036495	COVER,PLATEN		1
575	1036497	RIBBON,MASK		1
576	1014600	PAPER GUIDE ASSY.,SUPPORT		1
577	1005148	GUIDE,PAPER LOAD		1
578	1050387	FRAME,REAR		1
579	1082448	FRAME,FRONT		1
580	1036486	FRAME,SUB,RIGHT		1
581	1037282	GROUNDING PLATE MECH.,LWR		1
582	1008698	SHAFT,CR,GUIDE		1
583	1039818	BUSHING,PARALLEL,ADJUST		1
584	1036494	LEVER,GAP,ADJUST		1
585	1039412	CAP,LEVER;W	EPSON "COOL WHITE"	1
586	1036501	GROUNDING PLATE,MECH.		1
587	1005185	MOUNTING PLATE,MOTOR,CR		1
588	1010896	HOLDER,RIBBON MASK		1

EPSON

FX880+

REF	PART NO	DESCRIPTION	SPEC	QTY
589	1073525	OIL PAD(F334005140)		1
590	1039355	LEVER,RELEASE;W		1
591	1005220	CAM,CLUTCH,TRACTOR		1
592	1036498	HOLDER,CABLE		1
593	1008716	COMBINATION GEAR,31,5,8		1
594	1005224	SPUR GEAR,27		1
595	1013093	SPUR GEAR,34.5		1
596	1005226	SPUR GEAR,34		1
597	1005227	SPUR GEAR,15		1
598	1005218	INTERMITTENT GEAR		1
600	1005201	EXTENSION SPRING,71		2
601	1005232	COMPRESSION SPRING,200		2
602	1031702	SPRING PIN,2X18,F/B		1
606	1076213	HEXAGON NUT(B070200411)	M4	1
607	1076264	PLAIN WASHER(B100166012)	8X0.5X15	1
608	1006653	C.B.SCREW(B010303411)	M3X8	1
609	1001275	C.B.SCREW(B010303511)	M3X10	1
610	1073171	C.B.S. SCREW(B300204311)	M3X8	1
613	1005416	SHAFT,MOUNT,CR		2
614	1009032	TOOTHED LOCK WASHER A	M 4.3X0.45X8.5	1
615	1036499	SHEET,CABLE,HEAD		1
616	1037784	SHEET,RELEASE,CAP		1
617	1076285	LEAF SPRING(B101253990)	8.2X0.25X15	1
618	1031612	SPUR GEAR,36		1
619	1074777	RETAINING RING(B160101412)	TYPE-C	1
620	1025323	LEVER,DETECTOR,PR END,REAR		1
621	1025324	LEVER,PR END,SUPPORT		1
622	1025325	TORSION SPRING,0.26		1
623	1039378	PLAIN WASHER,3X0.5X8,F/ZB		1
650	F139000	PRINT HEAD		1
651	1080933	EXTENSION SPRING,16.45		1
652	1080935	HOLDER,PULLEY DRIVEN		1
END				

The parts to which no reference number is assigned will not be available as after-sale service parts.

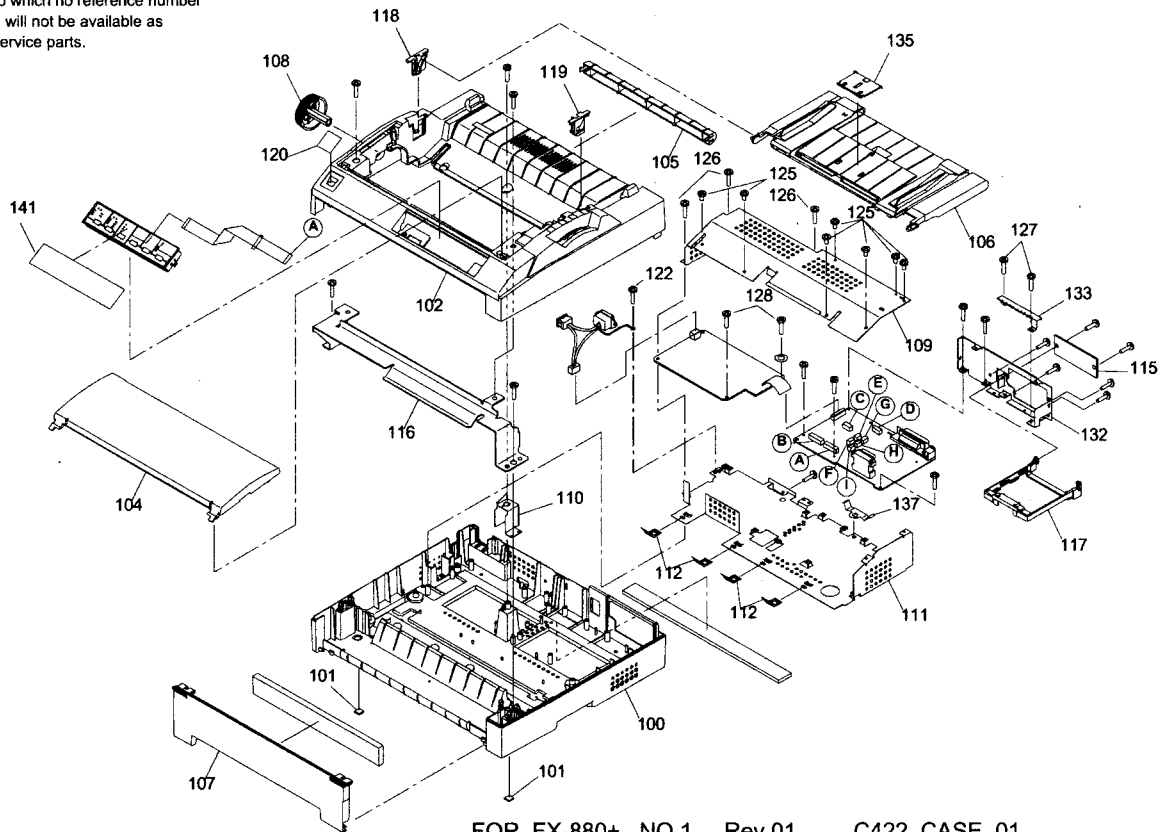

FOR FX-880+ NO.1 Rev.01 C422_CASE_01

The parts to which no reference number is assigned will not be available as after-sale service parts.

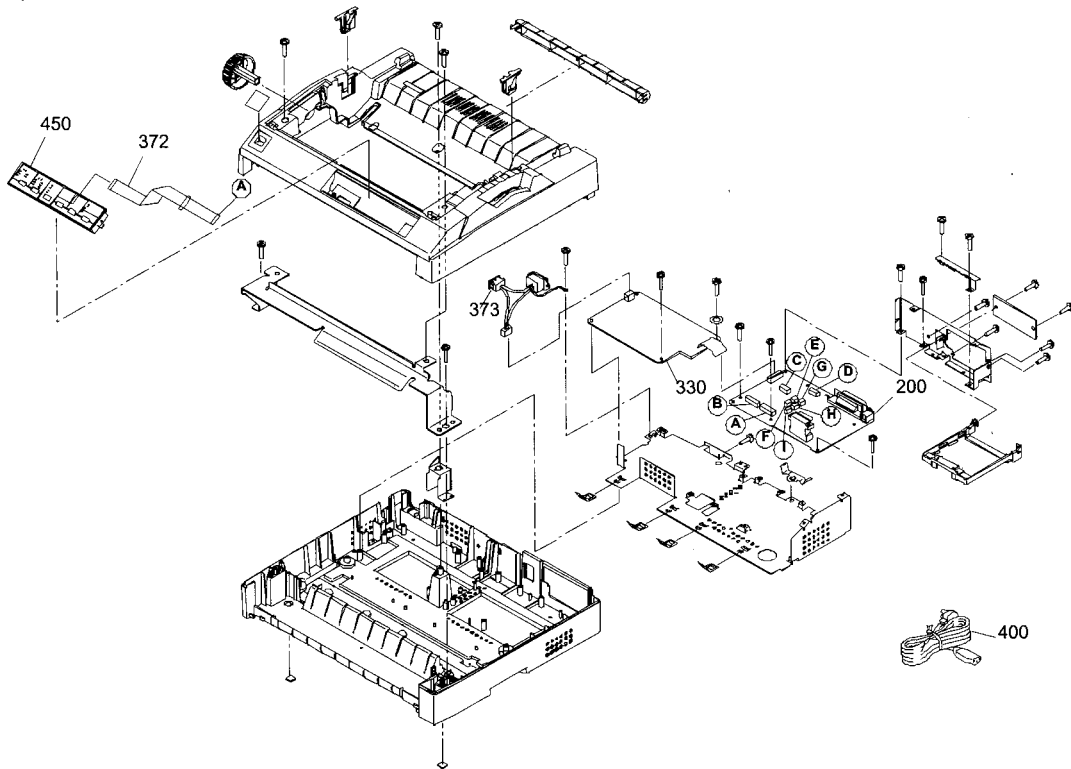

FOR FX-880+ NO.2 Rev.01 C422_ELEC_01

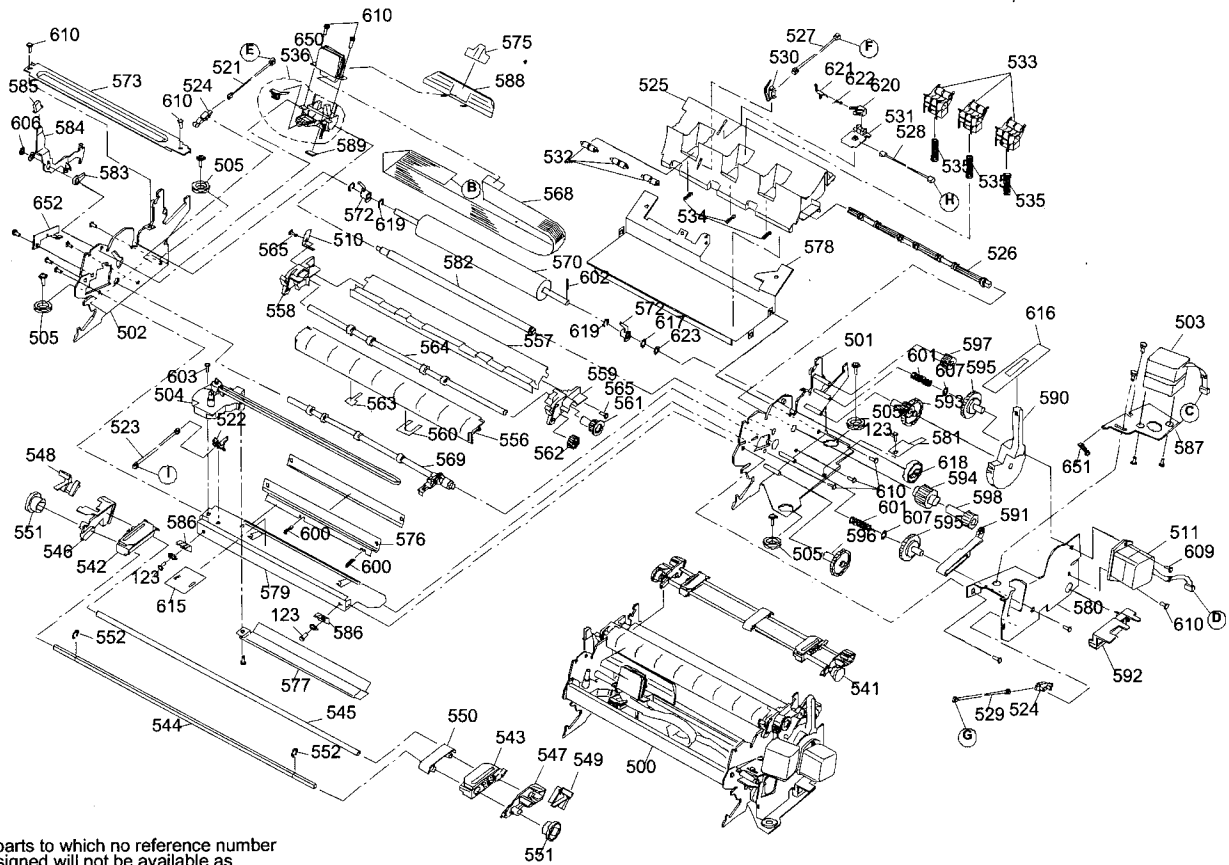

The parts to which no reference number is assigned will not be available as after-sale service parts.

EPSON

FX880+

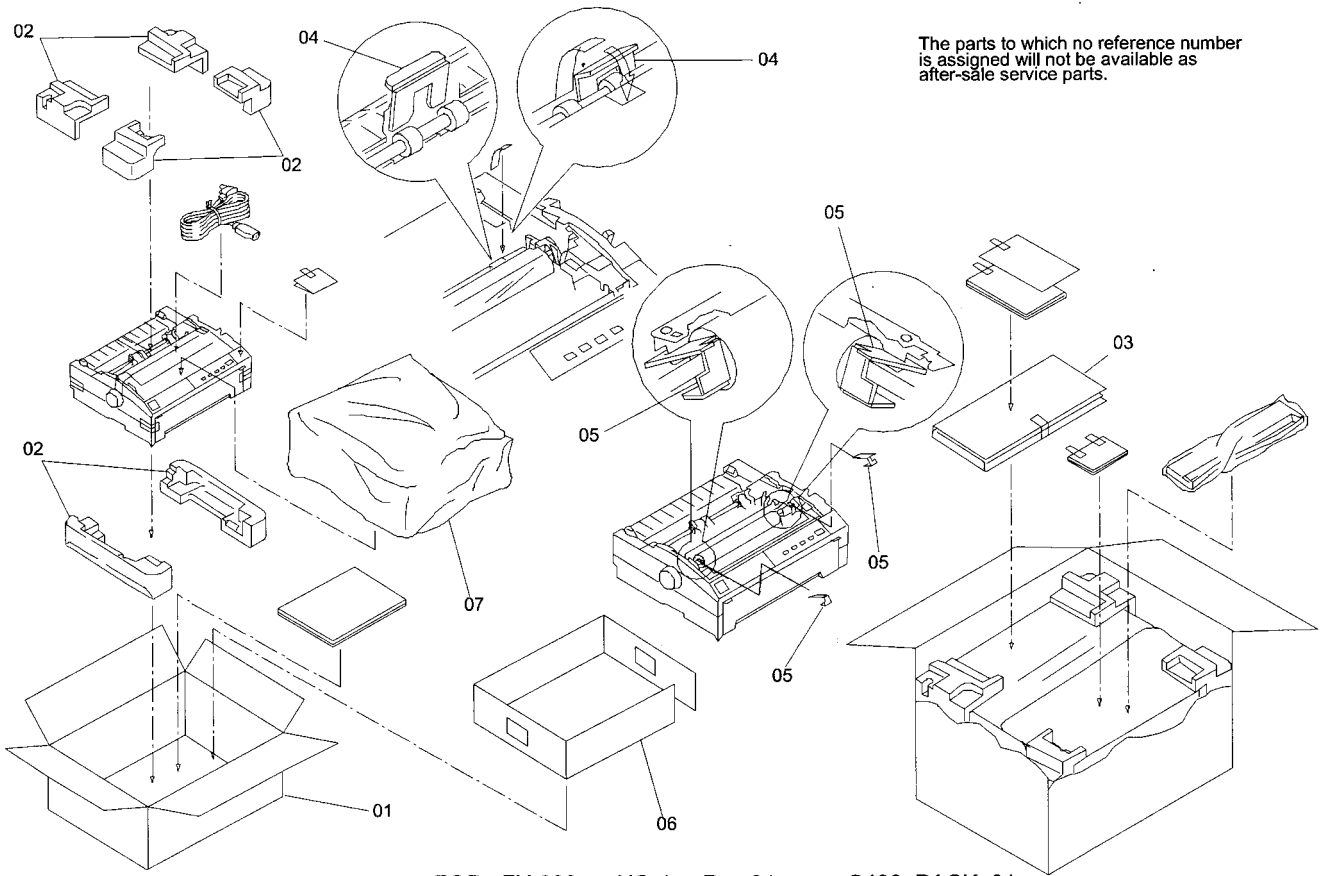

FOR FX-880+ NO.4 Rev.01

C422_PACK_01

The parts to which no reference number is assigned will not be available as after-sale service parts.

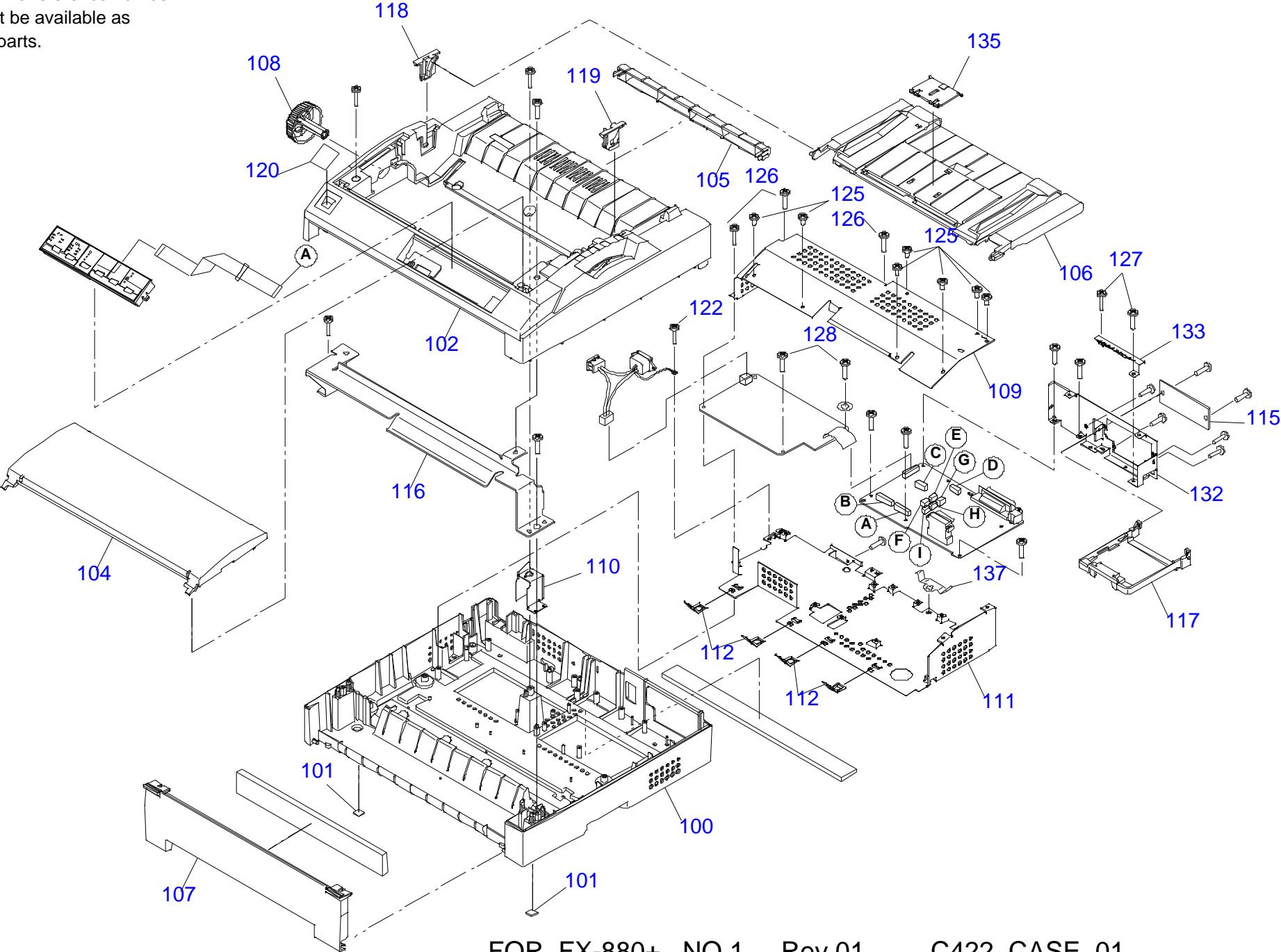

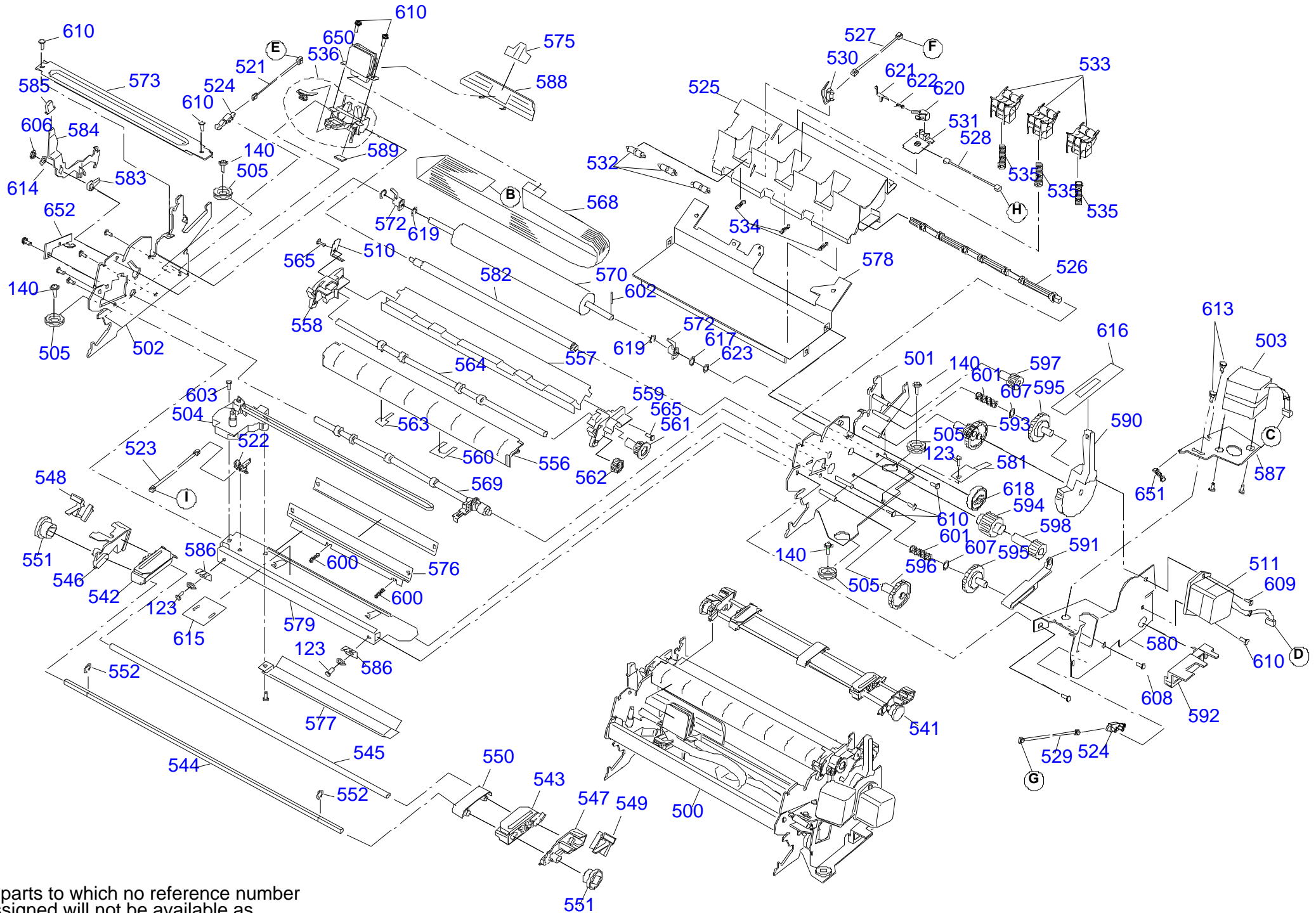

The parts to which no reference number is assigned will not be available as after-sale service parts.

The parts to which no reference number is assigned will not be available as after-sale service parts.

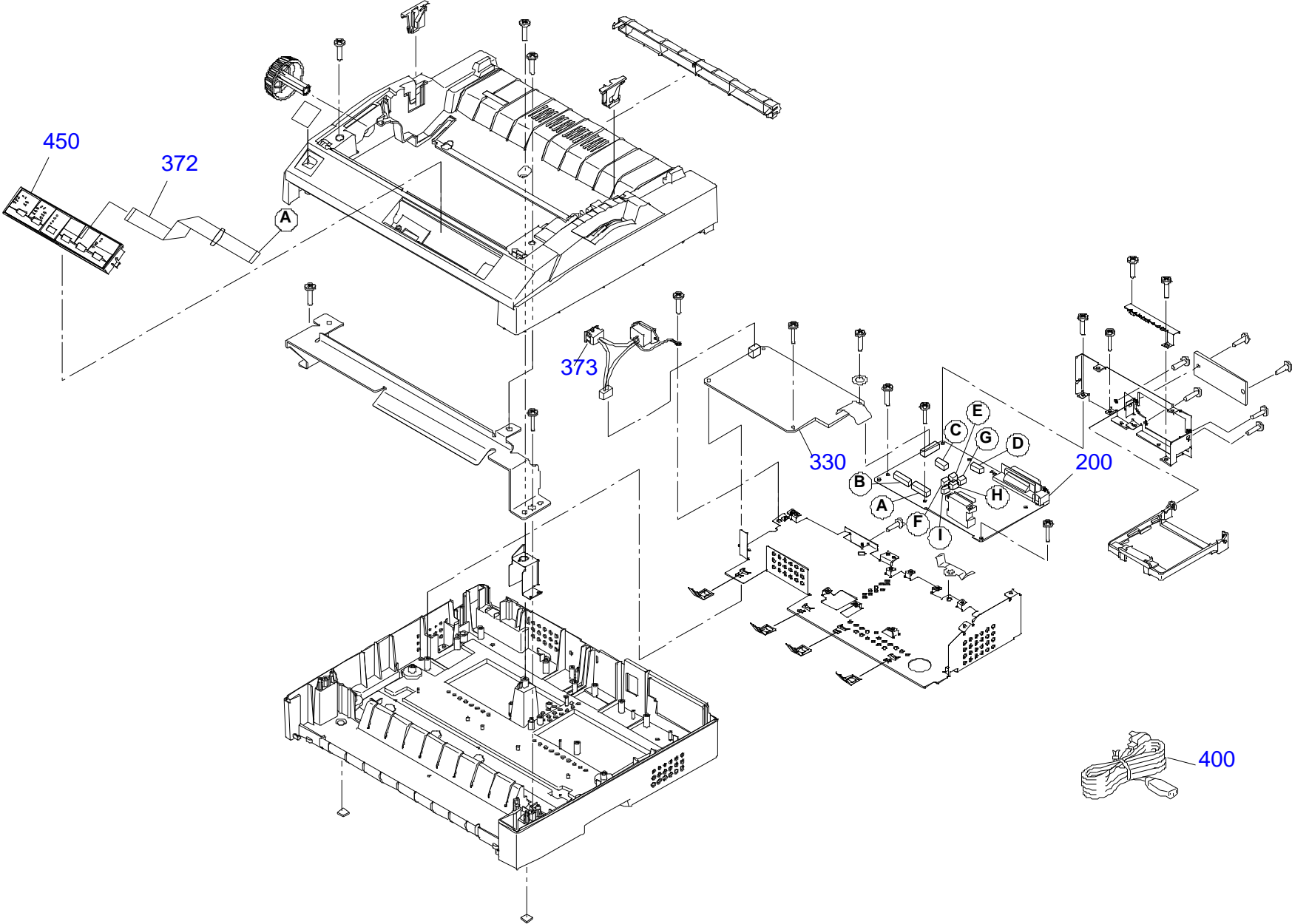

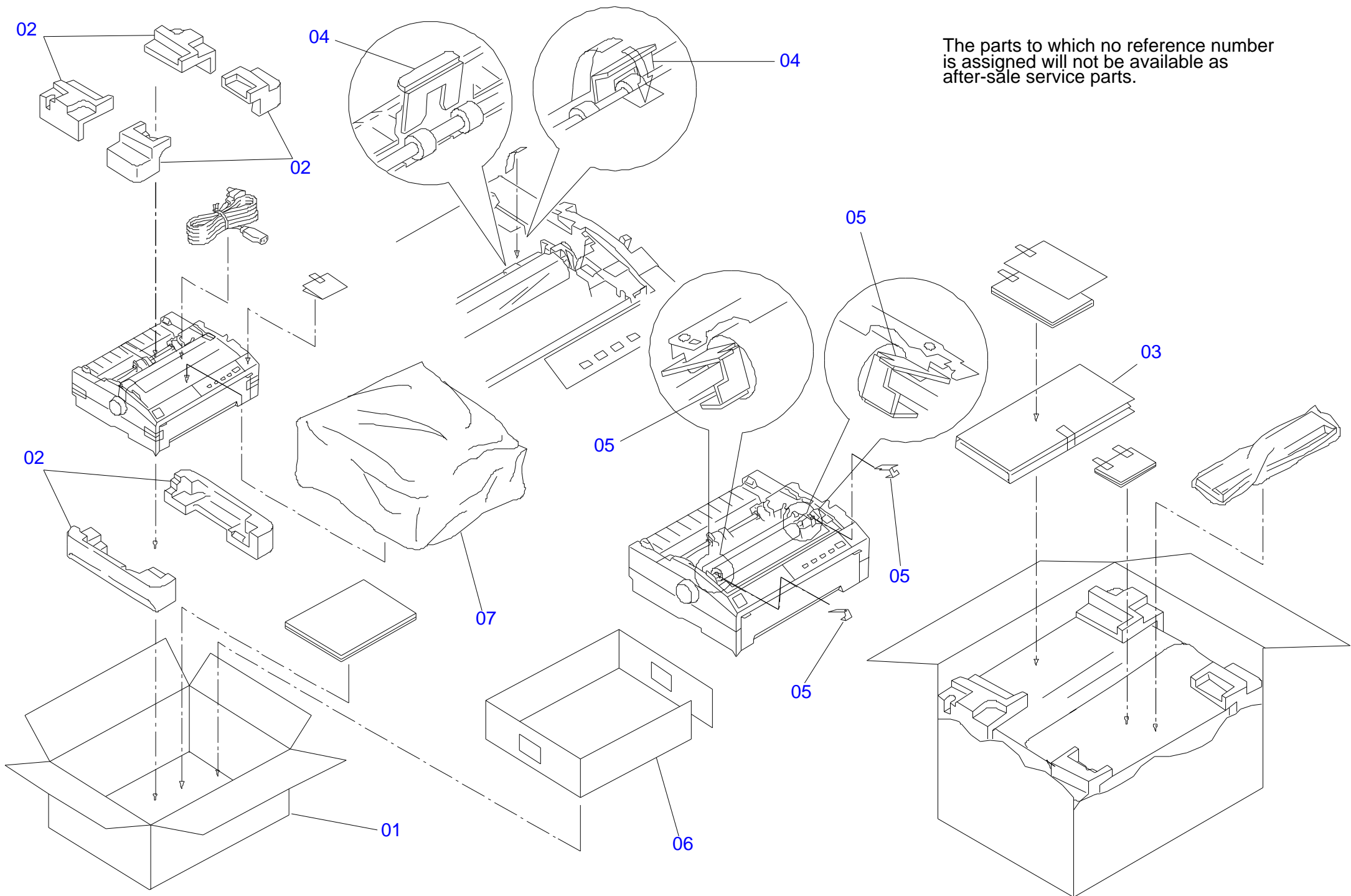

The parts to which no reference number is assigned will not be available as after-sale service parts.