

# EPSON

## EPL-6100L

Page No.:1

REF	PART NO	DESCRIPTION	SPEC	QTY
01-01	1090617	COVER	4127-1211-04	1
01-02	1090618	TRAY	4127-1207-03	1
01-03	1084551	GUIDE	4127-3750-03	1
01-04	1084552	ROLLER	4127-3730-03	2
01-05	1090619	GEAR ASSY	4127-0482-01	1
01-06	1090621	ROLLER	4127-3707-01	4
01-07	1090620	TOP COVER ROLLER ASSY	4127-0485-02	1
01-08	1090622	LEVER	4127-1204-03	1
01-09	1090623	TORSION SPRING	4127-3763-01	1
01-10	1090624	HOLDER	4127-3762-01	1
01-11	1090625	MEMBER	4127-3761-01	1
01-12	1090626	COVER	4127-1210-03	1
01-13	1090627	TORSION SPRING	4127-2020-01	2
01-14	1213018	FRONT COVER	4127-1223-27	1
01-15	1090632	RUBBER FOOT	4127-2015-01	2
01-23	1090640	TRAY	4127-1228-03	1
01-24	1090641	LABEL	4127-2024-01	1
01-25	1090642	LABEL	4127-2025-01	1
01-27	1084672	COVER	4127-1202-02	1
01-28	2055866	CONTROL PANEL	STANDARD	1
01-29	1058403	LOGO PLATE 10X40;C		1
01-32	1104274	STOPPER	4127-2021-01	2
02-01	1090647	TENSION SPRING	4127-3019-02	1
02-02	1090648	CAM	4127-3026-01	1
02-03	1090649	CAM	4127-3007-01	1
02-04	1090650	CAM	4127-3008-02 (SEE NOTE BELOW)	1
02-05	1084553	ROLLER	4127-3001-01	1
02-06	1090651	ROLLER	4127-3002-01	1
02-07	1090652	GEAR	4127-3014-01	1
02-08	1212574	GEAR	4127-3010-03 (SEE NOTE BELOW)	1
02-09	1090632	RUBBER FOOT	4127-2015-01	2
02-10	2056850	SOLENOID	9321-2000-32	1
02-11	1090892	ACTUATOR	4127-3521-02	1
02-12	2056851	PHOTO INTERRUPTER	4127-0901-01	1
02-13	1090655	PRESSURE SPRING	4127-3041-02	1
02-14	1090657	GUIDE	4127-3042-03	2
02-15	1090658	STOPPER	4127-3022-02	2
02-16	1090660	PRESSURE SPRING	4127-3516-02	2
02-17	1084555	REGULATING PLATE ASSY	4127-0491-02	1
02-18	1090661	TENSION SPRING	4127-3027-01	1
02-19	1090662	LEVER	4127-3025-01	1
02-20	1084556	SEPARATOR PAD	4127-0481-01	1
02-22	2057062	WIRE HARNESS ASSY	4127-6805-01	1
02-23	2057063	WIRE HARNESS ASSY	4127-6814-01	1
02-24	1084674	GUIDE	4127-3551-04	1
02-25	1084676	REINFORCEMENT PLATE	4127-3043-02	1
02-26	1084677	FRICTION SHEET	4127-3013-01	1
02-27	1091520	SEAL	4127-3044-01	1
02-29	1216079	HOLDER	4127-3020-06	1
02-30	1090635	GEAR	4127-3104-01	1
03-01	2060244	HEATER 230V	4127-6503-02	1
03-02	2056851	PHOTO INTERRUPTER	4127-0901-01	1

# EPSON

## EPL-6100L

Page No.:2

REF	PART NO	DESCRIPTION	SPEC	QTY
03-03	1090663	ACTUATOR	4127-5518-01	1
03-04	1090664	HOLDER	4127-5534-02	1
03-05	1104888	BUSHING	4127-5571-01	2
03-06	1104887	FUSING ROLLER	4127-5572-01	1
03-07	1090667	SEPARATOR	4127-5536-01	2
03-08	1090668	SEPARATOR	4127-5533-01	2
03-09	1042716	PRESSURE SPRING	4109-5516-01	4
03-10	1090669	BUSHING	4122-5522-01	1
03-11	2060245	THERMAL SWITCH	4127-6301-01	1
03-12	1053835	FUSING ROLLER	4121-5501-01	1
03-13	1040809	BUSHING	4109-5521-01	1
03-14	2069669	FUSING UNIT 220/240V	4127-0356-01	1
03-15	1084678	ROLLER	4127-5516-01	2
03-16	1084679	GEAR	4127-5513-01	1
03-17	1084680	GEAR	4127-5512-01	1
03-18	1084681	SEAL	4127-5550-04	1
04-01	1090671	TORSION SPRING	4127-2013-02	1
04-02	2027752	SWITCH	4109-6305-01	1
04-03	2060246	I/C GUIDE ASSY	4127-0480-01	1
04-04	2077815	DRIVE GEAR ASSY	4127-0305-01	1
04-05	2069671	MOTOR	9314-2100-11	1
04-06	2060249	MICRO-SWITCH	4127-6302-01	1
04-07	1090672	ROLLER	4127-3006-01	2
04-08	1084557	TRANSFER ROLLER	4127-4103-02	1
04-09	2056859	TRANSFER GUIDE ASSY	4127-0311-01	1
04-10	2077816	HARNESS ASSY	4127-6823-01	1
04-12	2057068	WIRE HARNESS ASSY	4127-6811-02	1
05-01	2069673	HV TRANSFORMER	4127-6207-01	1
05-02	2069674	FAN MOTOR	9313-1100-21	1
05-03	1090673	HOLDER	4127-2321-01	1
05-04	2056862	POWER SUPPLY 200V	4127-6202-02	1
05-05	2077817	P/H ASSY	4571-0535-01	1
05-05	2080492	PRINT HEAD ASSY(C)	4571-0555-01	1
05-06	2057067	WIRE HARNESS ASSY	4127-6804-03	1
N/A	2075186	BOARD ASSY., MAIN	5892B,WW	1
1305	1004686	SCREW		1
1318	1031790	SCREW		1
2902	1090674	SCREW	9646-0306-14	1
3501	1012113	TAPPING SCREW		1
3504	1004720	TAPPING SCREW		1
3541	1012096	TAPPING SCREW		1
3544	1053852	TAPPING SCREW	9735-0306-14	1
3704	1015399	TAPPING SCREW		1
3727	1046142	TAPPING SCREW	9739-0308-14	1
3906	1053854	TAPPING SCREW	9742-0306-13	1
3923	1040800	TAPPING SCREW		1
		<b>NOTE: REF 2-4 AND 2-8 REPLACED BY KIT 1279589</b>		
END				

# EPSON

## EPL-6100L

Page No.:3

The parts to which no reference number is assigned will not be available as after-sale service parts.

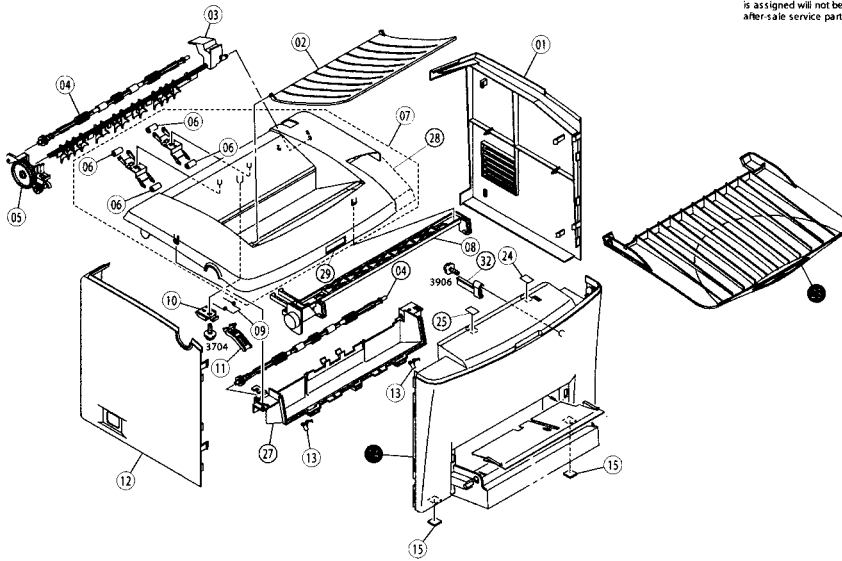

EPL-6100L NO.01 Rev.01 C502

The parts to which no reference number is assigned will not be available as after-sale service parts.

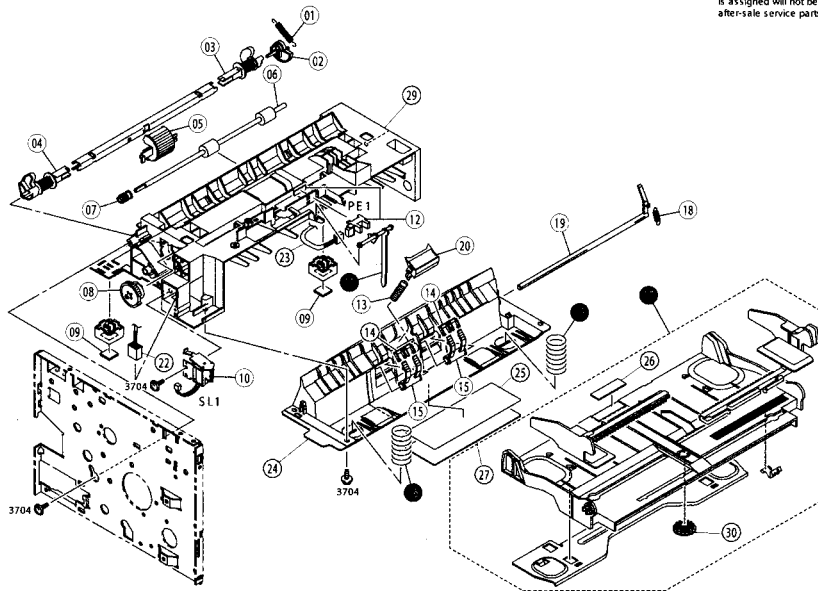

EPL-6100L NO.02 Rev.01 C502

# EPSON

## EPL-6100L

Page No.:4

The parts to which no reference number is assigned will not be available as after-sale service parts.

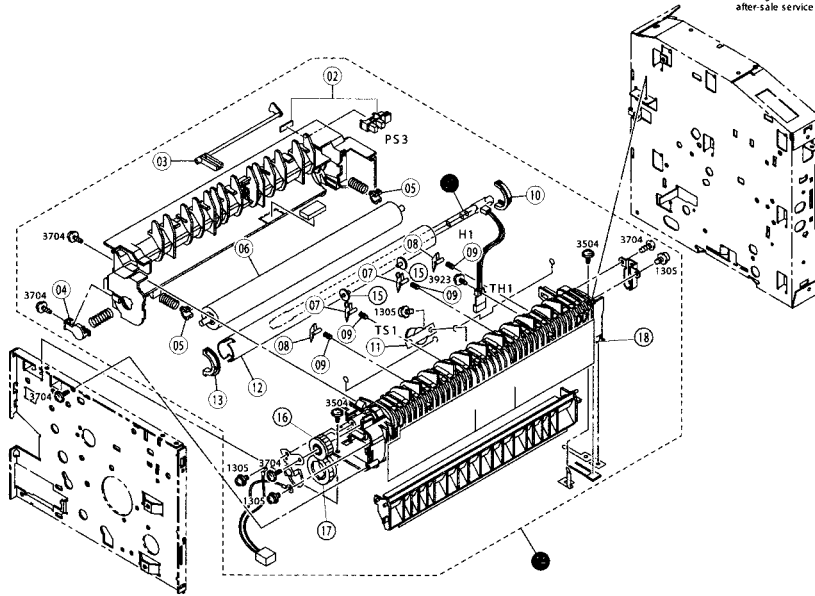

EPL-6100L NO.03 Rev.01 C502

The parts to which no reference number is assigned will not be available as after-sale service parts.

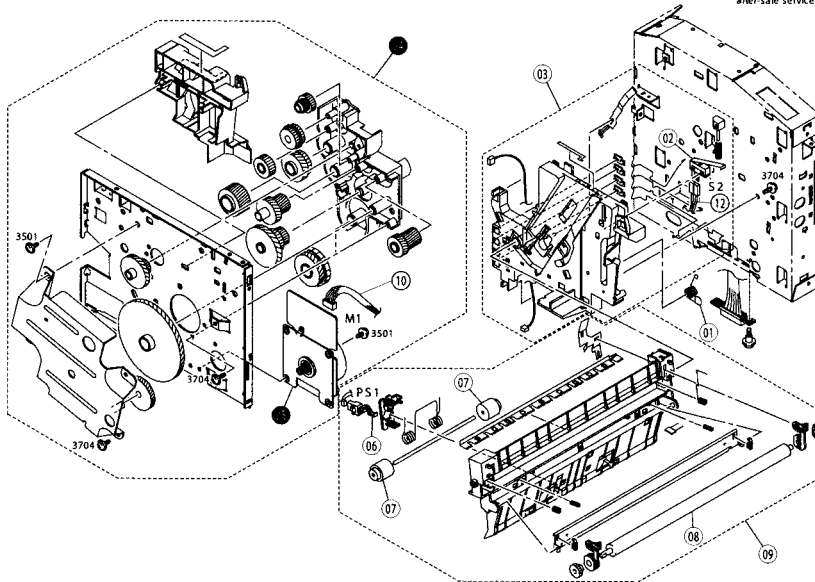

EPL-6100L NO.04 Rev.01 C502

# EPSON

## EPL-6100L

Page No.:5

The parts to which no reference number is assigned will not be available as after-sale service parts.

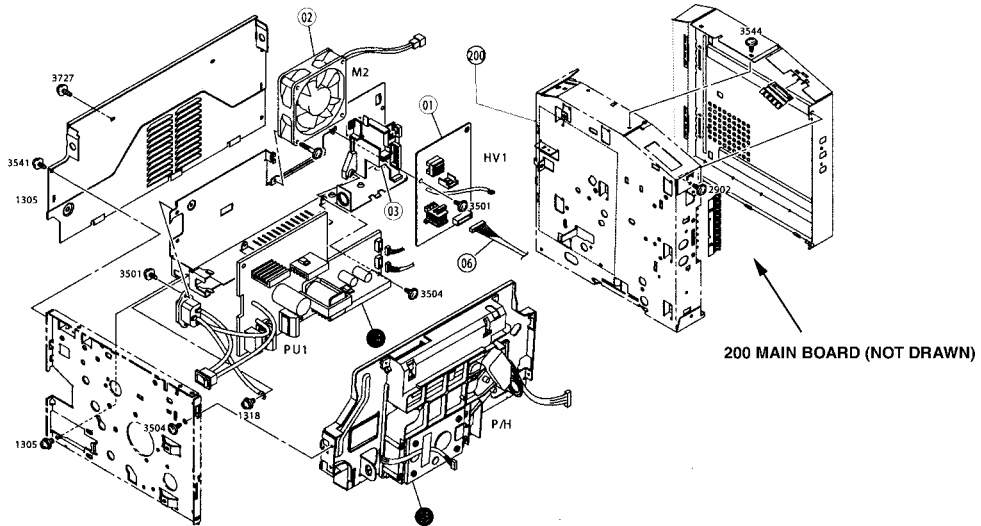

EPL-6100L NO.05 Rev.01 C502

The parts to which no reference number is assigned will not be available as after-sale service parts.

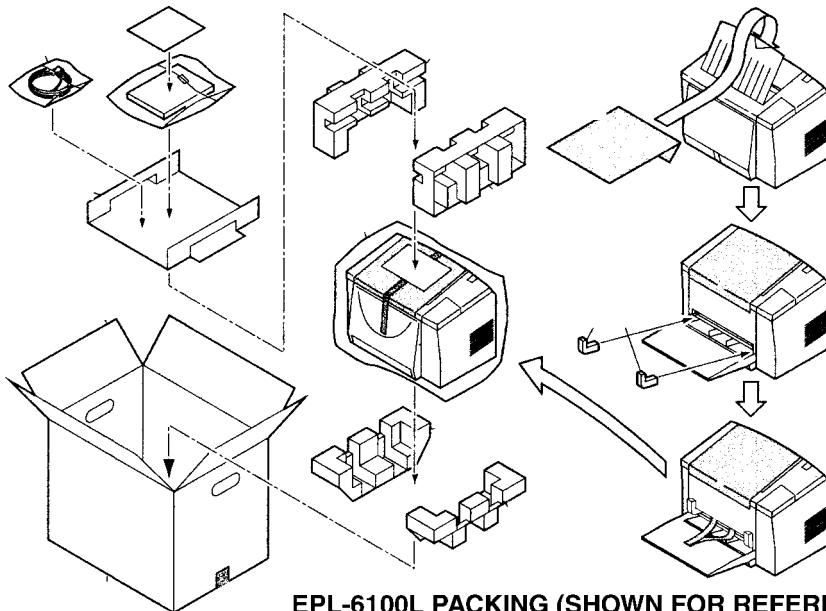

EPL-6100L PACKING (SHOWN FOR REFERENCE ONLY)

# C502-CASE-001

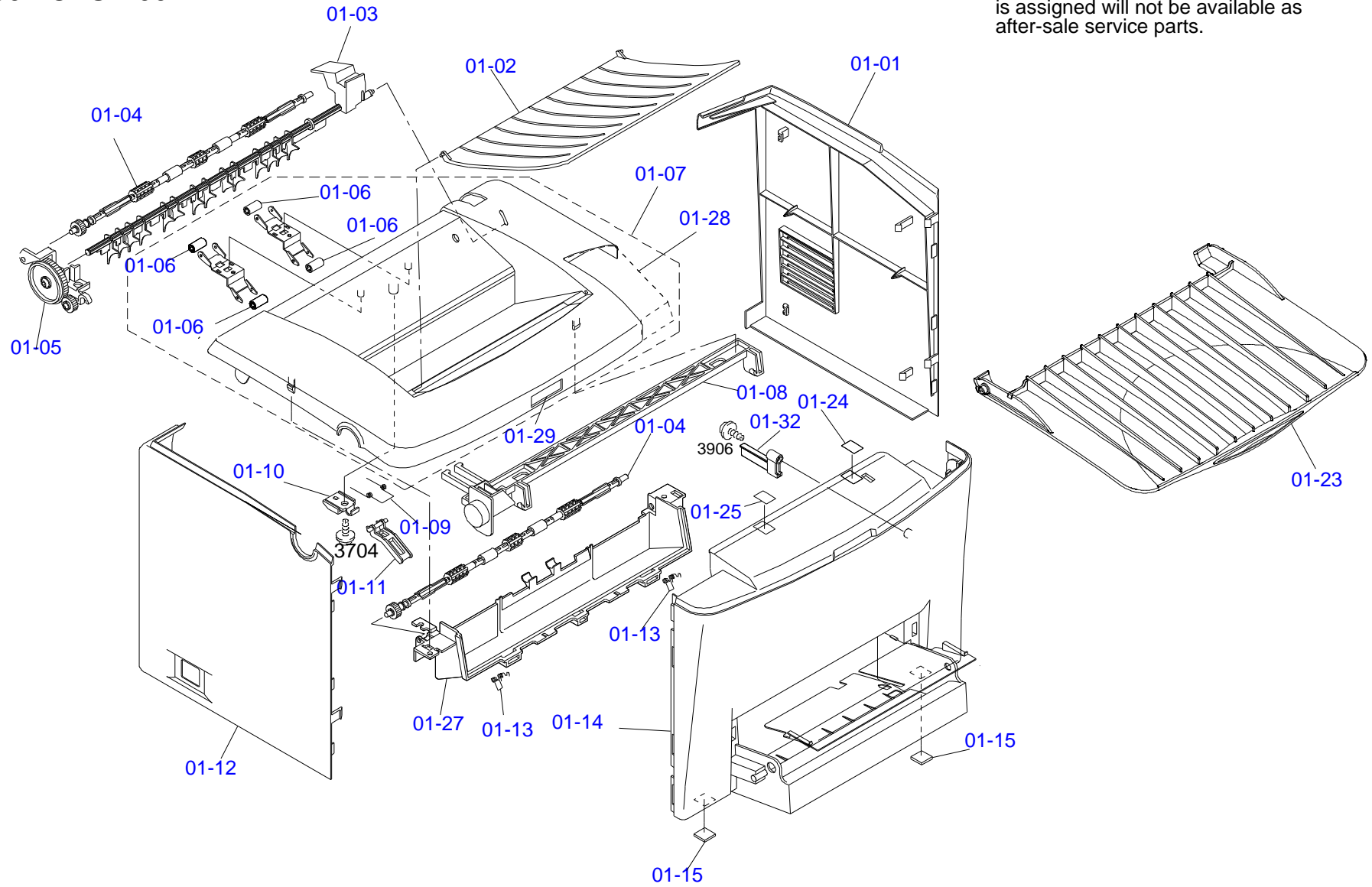

# C502-MECH-001

The parts to which no reference number is assigned will not be available as after-sale service parts.

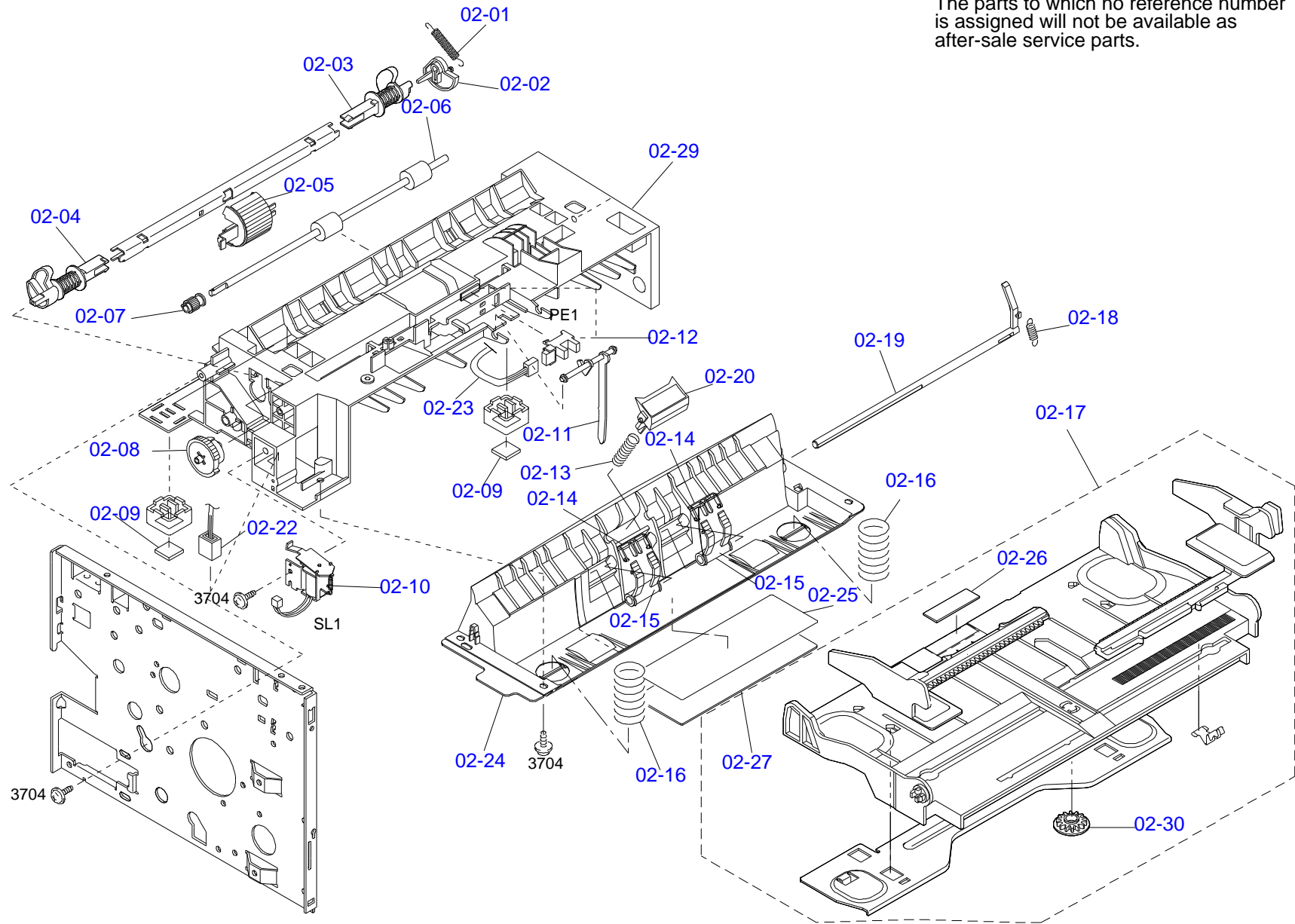

C502-MECH-002

The parts to which no reference number is assigned will not be available as after-sale service parts.

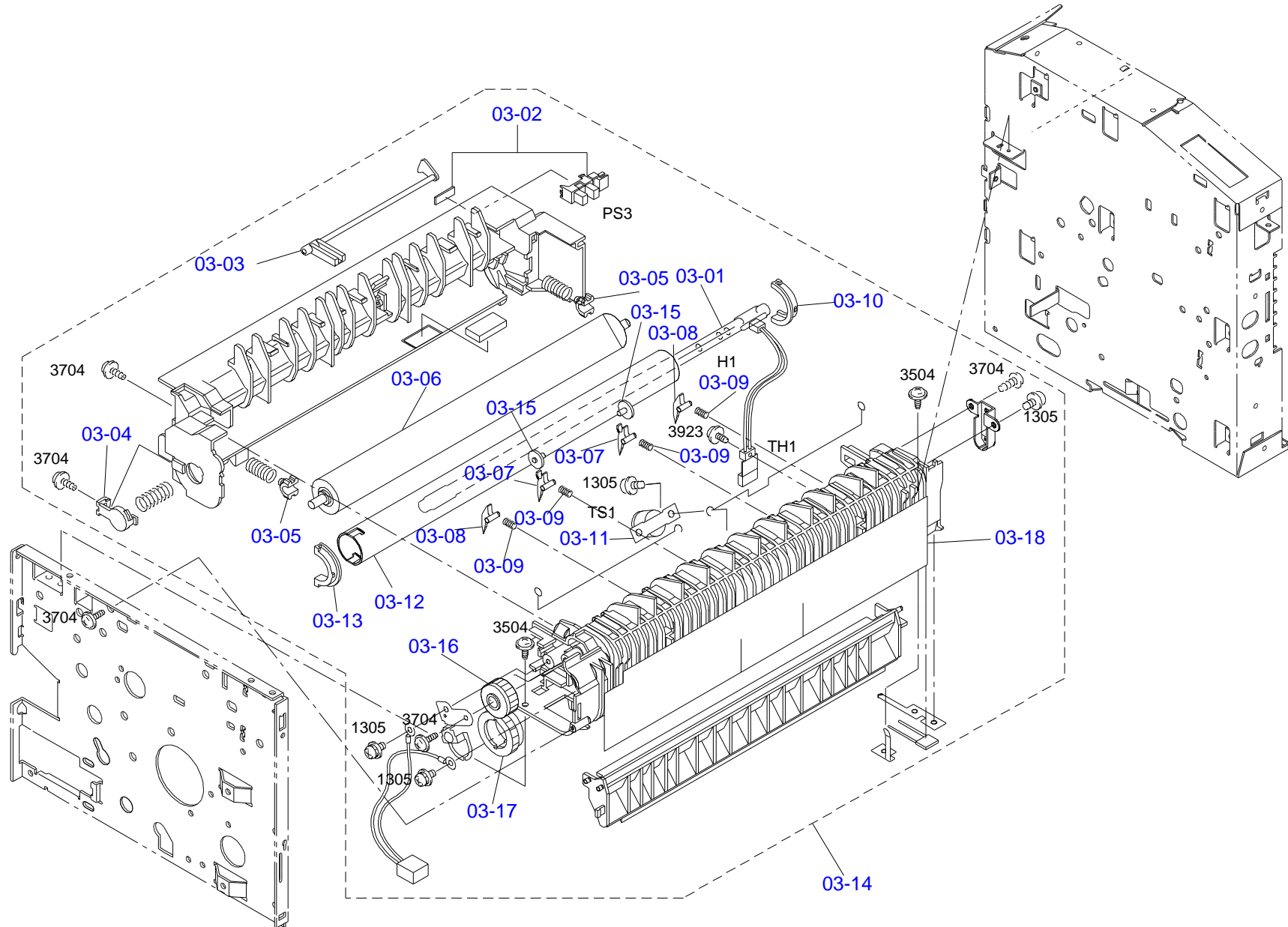



C502-MECH-003

The parts to which no reference number is assigned will not be available as after-sale service parts.

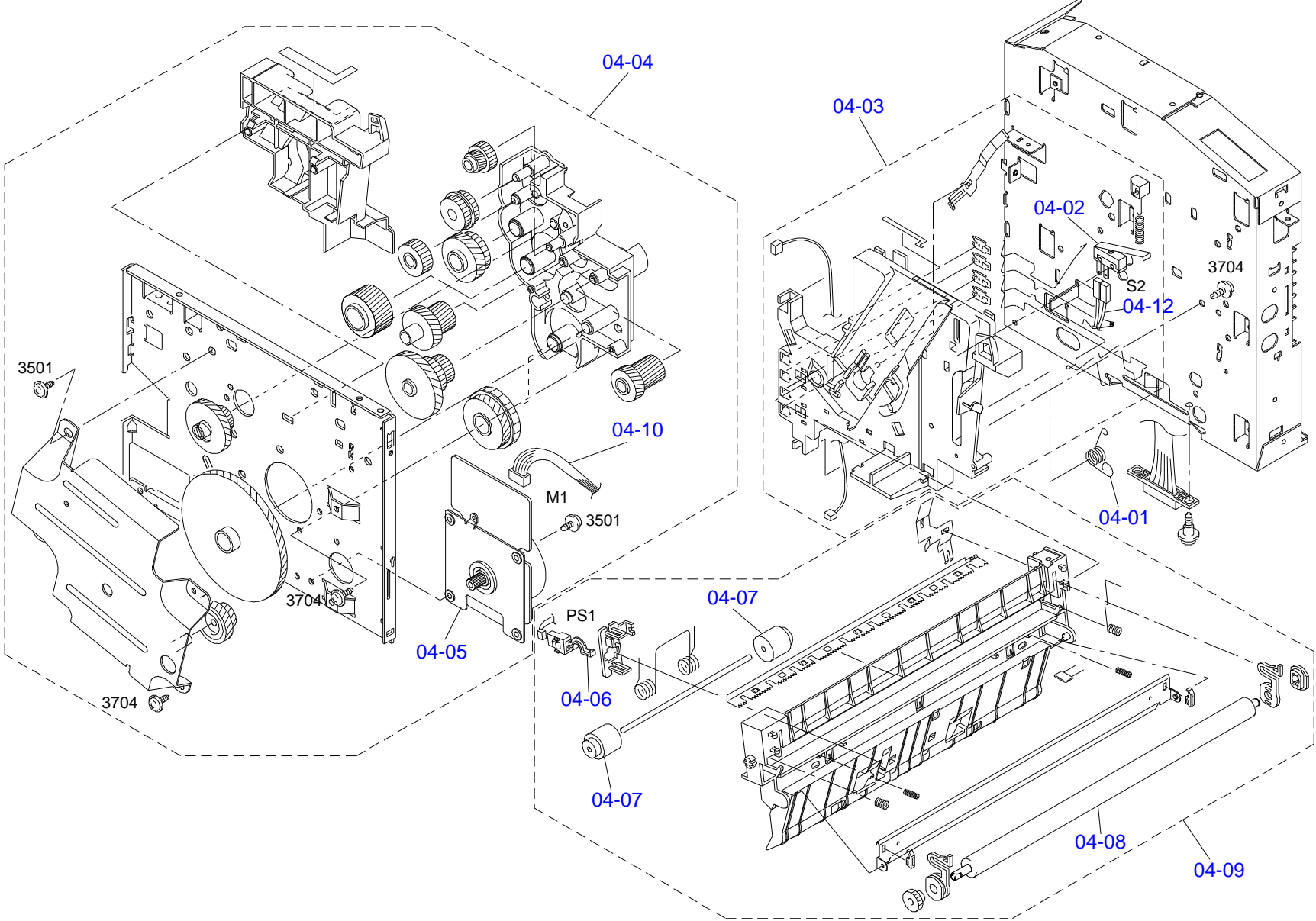

# C502-ELEC-001

The parts to which no reference number is assigned will not be available as after-sale service parts.

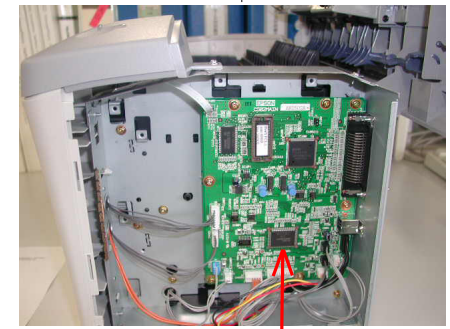
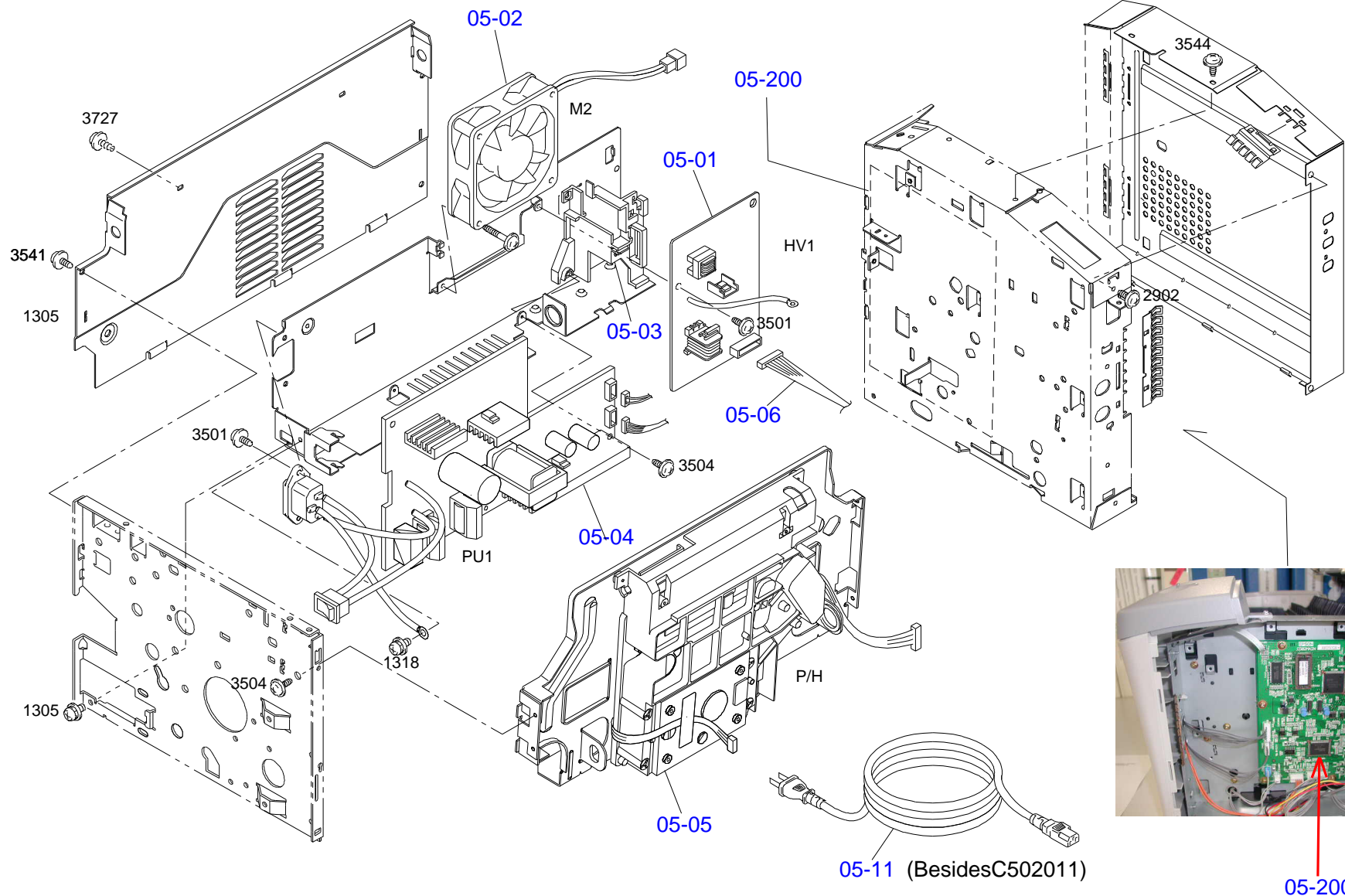

# C502-PACK-001

The parts to which no reference number is assigned will not be available as after-sale service parts.

